

INSTALLATION INSTRUCTIONS

Operator: Save these instructions for future use!

FAILURE TO READ AND FOLLOW ALL INSTRUCTIONS CAREFULLY BEFORE INSTALLING OR OPERATING THIS CONTROL COULD CAUSE PERSONAL INJURY AND/OR PROPERTY DAMAGE.

DESCRIPTION

The 36G/J54 and 36G/J55 combination gas valves are designed for direct spark ignition (DSI) and hot surface ignition (HSI) system applications. These valves are equipped with redundant and main solenoid valves that control gas flow to the main burners, a pressure regulator and a two-position on/off switch for regulation and electrical shut-off of the solenoid valves. The 36G/J55 is also equipped with a slow-opening pressure regulator for softer lighting characteristics. When the second solenoid is energized the valve operates at the second stage (high) outlet pressure setting.

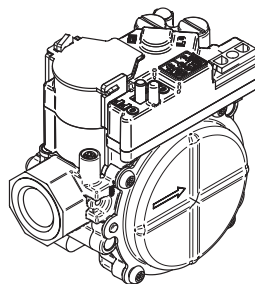

36G

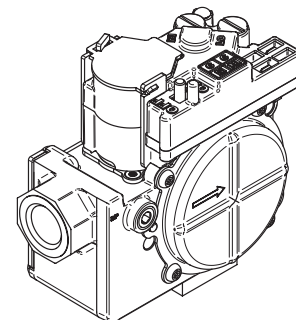

36J

SPECIFICATIONS

Type of Gas: Natural gas
LP gas (use conversion kit)

Pressure Regulator Setting:
Nat. Gas – Lo 1"-4" W.C., Hi 2"-5" W.C.
LP Gas – Lo 4.5"-10" W.C., Hi 8"-12" W.C.

NOTE: Do not set outlet pressure setting closer than 1" Nat. gas or 2" L.P.

Ambient Temperature: -40° to 175°F

Pressure Rating: 14" W.C. (½ PSI) max.

Voltage: 24 VAC

Frequency: 50/60 Hz

Current: .430 amps

Mounting Positions:
Multipoise – Control may be mounted in any position.

PIPE SIZES/CAPACITIES

Pipe Sizes Available (inches)	Capacity (BTU/hr) at 1" pressure drop across valve	
	AGA Std. Nat. Gas (1,000 BTU/cu. ft.)	LP Gas (2,500 BTU/cu. ft.)
1/2" x 1/2" NPT any combination	140,000	226,800

CONTENTS

Description 1
 Specifications 1
 Precautions 2
 Installation 2
 System Wiring
 Adjustment 4
 Pressure Regulator Adjustment
 Lighting Instructions 5
 Notes 6

PRECAUTIONS

⚠ WARNING



If you do not follow these instructions exactly, a fire or explosion may result causing property damage, personal injury or loss of life.

1. Failure to turn off electric or main gas supply to heating system could cause personal injury and/or property damage by shock, gas suffocation, fire, and/or explosion.
2. Do not use this control on circuits exceeding specified voltage. Higher voltage will damage the control and may cause shock or fire hazard.
3. **NEVER USE FLAME OR ANY KIND OF SPARK TO CHECK FOR GAS LEAKS—COULD CAUSE FIRE AND/OR EXPLOSION.**
4. Do not use a control set for natural gas with LP gas, or a control set for LP gas with natural gas. Personal injury and/or property damage, gas suffocation, fire, and/or explosion may result.

⚠ WARNING



If you do not follow these instructions exactly, a fire or explosion may result causing property damage, personal injury or loss of life.

1. Do not use a gas valve which appears to be damaged. A damaged valve may cause personal injury and/or property damage due to shock, gas suffocation, fire, and/or explosion. Contact supplier to replace any valve that appears to have been damaged.

⚠ CAUTION

Do not short out terminals on gas valve or primary control to test. Short or incorrect wiring can cause equipment damage, property damage and/or personal injury.

This control is not intended for use in locations where it may come in direct contact with water. Suitable protection must be provided to shield the control from exposure to water (dripping, spraying, rain, etc.).

INSTALLATION

1. Turn off electrical power to the system at the fuse box or circuit breaker. Also turn off the main gas supply.
2. If replacing an existing valve, disconnect all plumbing and electrical connections from the old control.
3. The control may be installed in any position. The arrow on the bottom plate indicates the direction of inlet gas flow.

NOTE

All piping must comply with local codes, ordinances, and/or national fuel gas codes.

4. You should use new pipe that is properly chamfered, reamed, and free of burrs and chips. If you are using old pipe, be sure it is clean and free of rust, scale, burrs, chips, and old pipe joint compound.
5. Apply pipe joint compound (pipe dope) that is approved for all gases, only to the male threads of the pipe joints. **DO NOT** apply compound to the first two threads (see figure 2 for typical piping connections).

6. If you are using a vise or open-end wrench to hold the valve while installing piping, do not tighten excessively, as this may damage the valve. (Torque: 375 in-lb maximum.) Do not cross-thread during installation as this may damage the valve.
7. See **SYSTEM WIRING** when making electrical connections. After all gas and electrical connections are completed, turn gas on and check for gas leaks with leak detection solution or soap suds. Bubbles forming indicate a leak. **SHUT OFF GAS AND FIX ALL LEAKS IMMEDIATELY.**

SYSTEM WIRING

Refer to and follow the appliance manufacturer's wiring diagram. Refer to figures 3 and 4 for terminal identification.

NOTE

All wiring should be installed according to local and national electrical codes and ordinances.

Always check that the electrical power supply used agrees with the voltage and frequency shown on the gas control.

NOTE: A MANUAL SHUTOFF VALVE MUST BE INSTALLED WITHIN 6 FEET OF THE EQUIPMENT

NOTE: ALWAYS INCLUDE A DRIP LEG IN PIPING

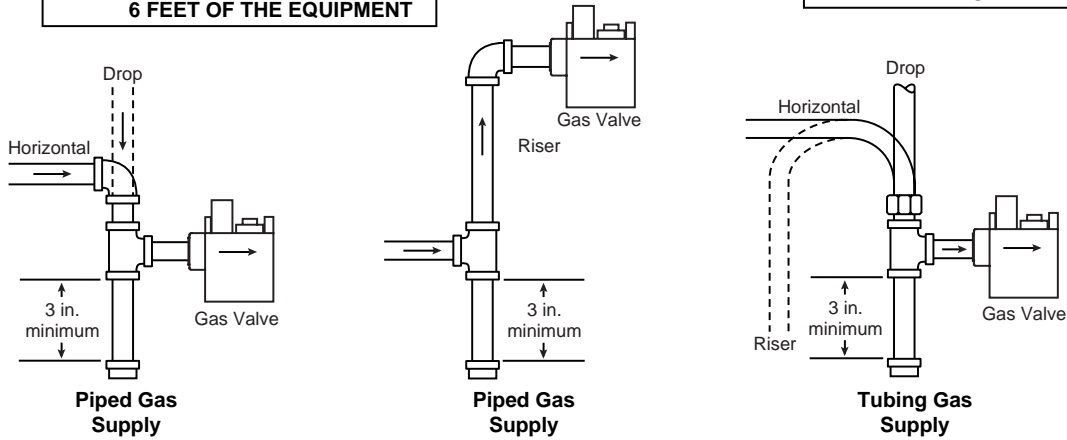

Fig. 2 – Typical gas valve piping

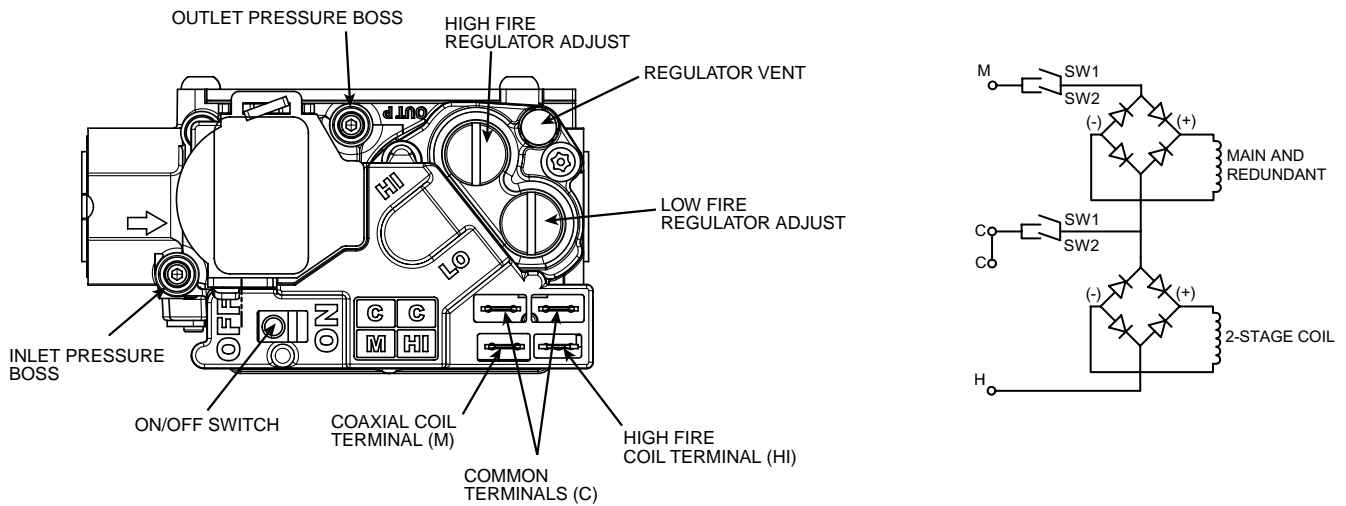

Fig. 3 – Four spade connector wiring diagram

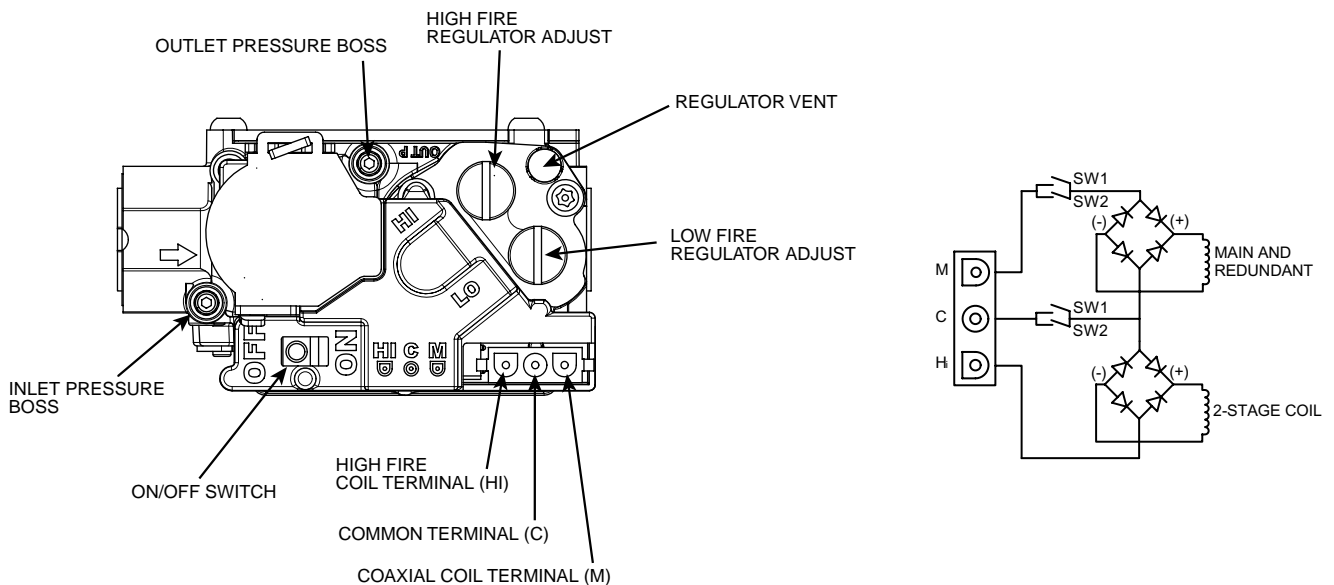

Fig. 4 – Mate-N-Lok wiring

ADJUSTMENT

PRESSURE REGULATOR ADJUSTMENT

These controls are shipped from the factory with the regulator set as specified on the control label. Consult the appliance rating plate to ensure burner manifold pressure is as specified. If another outlet pressure is required, follow these steps.

NOTE

Natural Gas: Low outlet pressure will be factory-adjusted in the 1 to 4" W.C. range and high outlet pressure will also be factory-adjusted in the 2 to 5" W.C. range.

The valve cannot be adjusted outside this range and the high outlet pressure setting must always be set at least **1"** above the low outlet pressure setting.

LP Gas: Low outlet pressure will be factory-adjusted in the 4.5 to 10" W.C. range and high outlet pressure will be adjusted in the 8 to 12" W.C. range.

The valve cannot be adjusted outside this range and the high outlet pressure setting must always be set at least **2"** above the low outlet pressure setting.

OUTLET PRESSURE ADJUSTMENT

1. Turn off all electrical power to the system.
2. Some models feature pressure tap bosses that eliminate the need for a separate fitting when checking pressure (See Figure 5). If valve is equipped with pressure tap bosses, back outlet pressure test screw out one turn (counterclockwise, not more than one turn). For models with 1/8 NPT threaded taps, the outlet pressure tap plug will need to be removed and a separate hose fitting installed.
3. Attach a hose and manometer to the outlet pressure boss of the valve (see fig. 5).
4. Turn on power and energize main solenoid. Do not energize the HI solenoid.
5. Remove regulator cover screw from the low outlet pressure regulator adjust tower (fig. 5) and turn screw clockwise (↻) to increase pressure, or counterclockwise (↺) to decrease pressure (see fig. 6) Always adjust regulator according to original equipment manufacturer's specifications listed on the appliance rating plate. Replace regulator cover screw.
6. Energize main solenoid as well as the HI terminal.
7. Remove regulator cover screw from the high outlet pressure regulator adjust tower (fig. 5) and turn screw clockwise (↻) to increase pressure, or counterclockwise (↺) to decrease pressure (see fig. 6) Always adjust regulator according to original equipment manufacturer's specifications listed on the appliance rating plate. Replace regulator cover screw.
8. Turn off all electrical power to the system.
9. Remove manometer hose from outlet pressure boss or fitting.

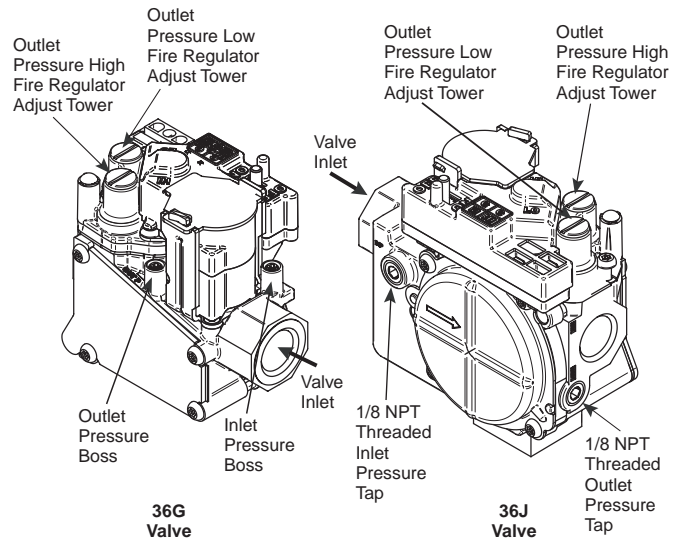

Figure 5
Pressure port and regulator adjust locations

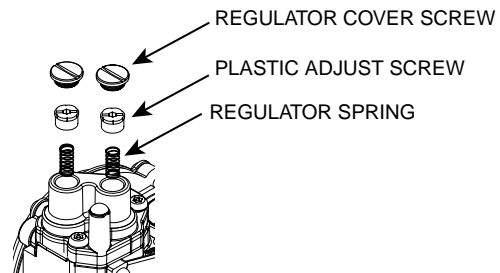

Figure 6

10. For pressure tap boss models, turn outlet pressure test screw in to seal pressure port (clockwise, 7 in-lb minimum). For 1/8 NPT threaded tap models, remove hose fitting and re-install pressure tap plug. Tighten to 60 in-lb max.
11. Turn on electrical power to the system.
12. Turn on system power and energize valve.
13. Using a leak detection solution or soap suds, check for leaks at pressure boss screw or pressure tap plug. Bubbles forming indicate a leak. SHUT OFF GAS AND FIX ALL LEAKS IMMEDIATELY.

NOTE

For gas to gas conversion, consult your dealer for appropriate conversion kit.

LIGHTING INSTRUCTIONS

FOR YOUR SAFETY READ BEFORE OPERATING

⚠ WARNING



If you do not follow these instructions exactly, a fire or explosion may result causing property damage, personal injury or loss of life.

- A. This appliance does not have a pilot. It is equipped with an ignition device which automatically lights the burner. Do **not** try to light the burner by hand.
- B. **BEFORE OPERATING** smell all around the appliance area for gas. Be sure to smell next to the floor because some gas is heavier than air and will settle on the floor.

FOR YOUR SAFETY "WHAT TO DO IF YOU SMELL GAS"

- Do not try to light any appliance.
 - Do not touch any electrical switch; do not use any phone in your building.
 - Immediately call your gas supplier from a neighbor's phone. Follow the gas supplier's instructions.
 - If you cannot reach your gas supplier, call the fire department.
- C. Use only your hand to move the gas control switch. **Never use tools.** If the switch will not move by hand, don't try to repair it, call a qualified service technician. Force or attempted repair may result in a fire or explosion.
- D. Do not use this appliance if any part has been under water. Immediately call a qualified service technician to inspect the appliance and to replace any part of the control system and any gas control which has been under water.

OPERATING INSTRUCTIONS

1. **STOP!** Read the safety information above on this label.
2. Set the thermostat to lowest setting.
3. Turn off all electric power to the appliance.
4. This appliance is equipped with an ignition device which automatically lights the burner. Do **not** try to light the burner by hand.

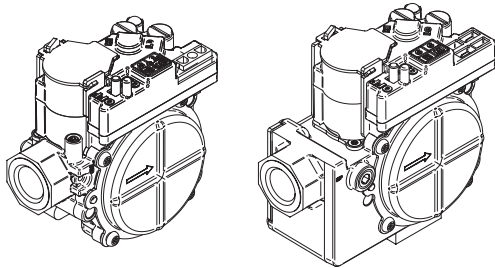

5. Remove control access panel.
6. Wait five (5) minutes to clear out any gas. If you then smell gas, STOP! Follow "B" in the safety information above on this label. If you don't smell gas, go to the next step.
7. Push gas control switch to "ON."
NOTE: Do not force.
8. Replace control access panel.
9. Turn on all electric power to the appliance.
10. Set thermostat to desired setting.
11. If the appliance will not operate, follow the instructions "To Turn Off Gas To Appliance" and call your service technician or gas supplier.

TO TURN OFF GAS TO APPLIANCE

1. Set the thermostat to lowest setting.
2. Turn off all electric power to the appliance if service is to be performed.
3. Remove control access panel.
4. Push gas control switch to "OFF." **Do not force.**
5. Replace control access panel.

NOTES

NOTES

For additional product information, please visit our web site.

The Emerson logo is a
trademark and service mark
of Emerson Electric Co.

www.white-rodgers.com