



SWANSTONE®

THE REINFORCED SOLID SURFACE

Installation Procedure for TK-6072 & TK-105 Wall Panel Trim Kits

An adjustable trim kit unit will accommodate 30" to 32" bathtub depths. Designed to fit over Swanstone Model SS bathtub panels or Model SS shower panels only.

INCLUDED IN CARTON: TK-6072

Four 3-7/8" x 74" trim strips and two 1-1/4" x 7/8" x 72" corner moldings designed to fit Swanstone 60" and 72" high x 5' wide (or smaller) bathtub and shower wall panel systems.

TK-105

Two 3-7/8" x 105" trim strips, two 3-7/8" x 74" trim strips and two 1-1/4" x 7/8" x 96" corner moldings. All are designed to fit Swanstone 96" high x 5' wide (or smaller) shower wall panel systems including 96" NEO walls.

NOTE

All Trim Kits include one 11 oz. tube of adhesive and one 6 oz. tube of color coordinated caulk.

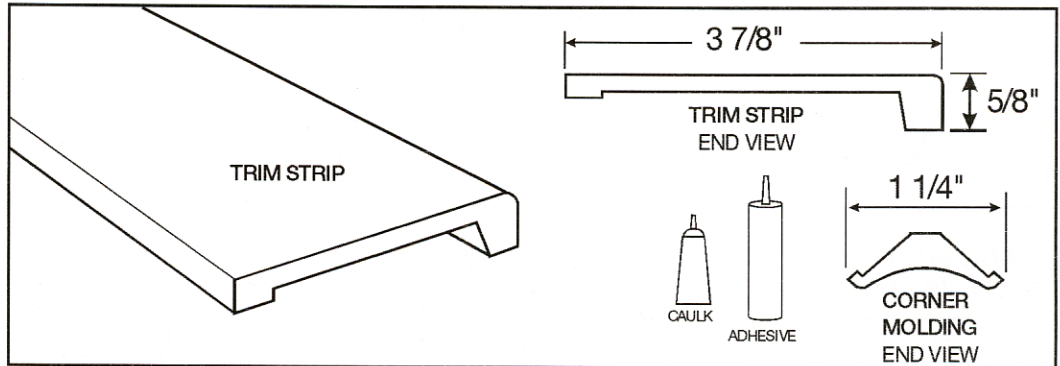

TOOLS REQUIRED TO INSTALL

Tools needed are a carbide tip saber saw, drill, ruler, level, masking tape, and caulking gun. For best results and extended tool life, we recommend professional or industrial rated power tools. All routing and cutting tools should have a minimum rating of 10 AMPS.

CUTTING AND ROUTING TOOLS

Dependent on the type of cut or edge detail required, one or more of the following tools may be required.

- Circular saw: Minimum 40-tooth carbide blade (triple chip grind, 60-tooth will give a smooth, clean cut)
- Portable power plane with carbide blades or cutter heads.
- Saber Saw (straight up/down blade travel). Fine plywood carbide blade or blade with no tooth overhang (14 teeth per inch)
- Miter saw

IMPORTANT

If you are installing the TK-6072 bathtub wall panel trim kit over a Swanstone SS-60 bathtub wall panel unit, trimming of the center soap dish panel will be required. You must follow the procedure shown in step #3.

TRAIL FIT BEFORE YOU START

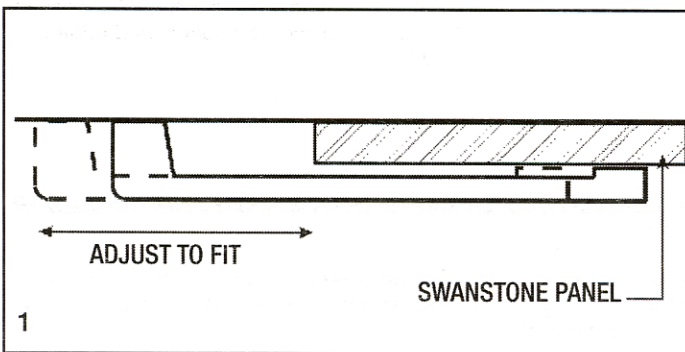

1. VERTICAL TRIM STRIP

Select any two of the trim strips. A 45° mitered cut is recommended for seaming the vertical and horizontal strips. The outside, or long, measurement of the vertical trim strip should be approximately 7/8" greater than the vertical measurement of the wall panel. Set each vertical trim strip into position. The most desirable placement will line up the front edge of the trim strip with the front edge of the bathtub or shower floor. Trial fit all pieces before final application.

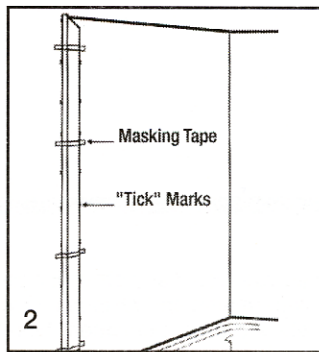

2. VERTICAL FIT

For a proper vertical fit, check with a level. Temporarily secure trim strip to the wall with masking tape. Mark the location of the vertical trim strips with "tick" marks. These "tick" marks will be used for final fit.

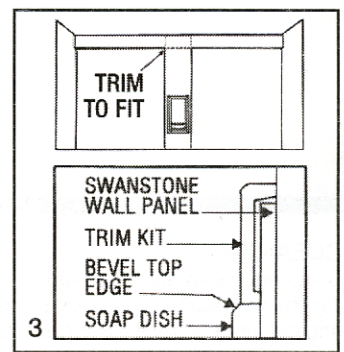

3. IMPORTANT

If you are installing the TK-6072 bathtub wall panel trim kit over a Swanstone SS-60 bathtub wall panel unit, it will be necessary to trim the center soap dish panel. Using the proper cutting tools (see Cutting and Routing Tools), measure and trim as needed.

(continued)

INSTALLATION INSTRUCTIONS CONTINUED

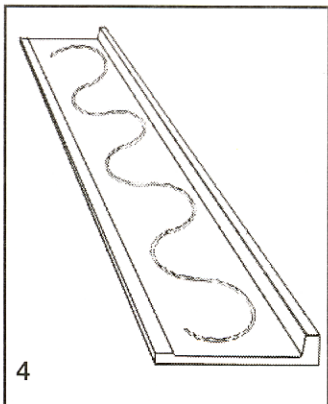

4. BACK WALL-HORIZONTAL TRIM STRIP

Transfer measurement from the back wall onto either one of the two remaining trim strips. Using the proper cutting tools (see "Cutting and Routing Tools") trim as needed. Following the pattern illustrated, run a 1/8" bead of adhesive along the entire length of the trim strip. Final fit by setting into position.

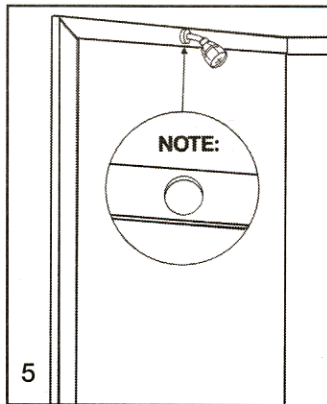

5. SIDE WALLS-HORIZONTAL TRIM STRIPS

Transfer measurements from the side walls onto the remaining trim strip. Using the proper cutting tools (see "Cutting and Routing Tools") trim as needed. Follow the adhesive pattern in step #4 and final fit trim strips into place.

NOTE

It may be necessary to cut one of the side wall trim strips to allow for the location of the shower arm. Measure and locate the position of the desired cut. Use router, spade bit, twist drill, or hole saw only. **DO NOT USE AUGER BITS.** Cut hole 1/2" larger than the diameter of the pipe. Drill from the finished side of the panel.

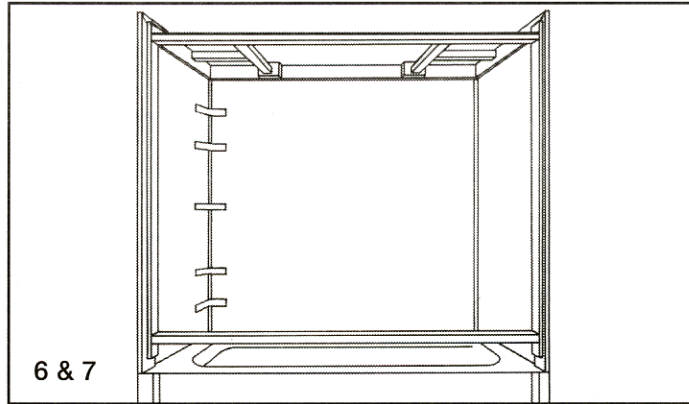

6. FINAL FIT

You are now ready to final fit the vertical trim strip. Repeat the adhesive pattern used in both steps #4 and #5. Using the "tick" marks from step #2, position the vertical trim strips into place.

NOTE

To promote contact until adhesive sets, use temporary bracing and allow adhesive to cure overnight. Temporary bracing may be constructed and wedged into position as illustrated by using lengths of 1 x 2's, 2 x 2's, 1 x 3's. Lumber should be cut as needed.

POSITIVELY NO
HAMMERING OR NAILING
IS TO BE DONE.

7. CORNER MOLDING

Locate the placement of the corner moldings and measure the vertical areas of the corner seam. Trim corner molding to desired length and trial fit. If installing corner moldings around an SS-7211 Swanstone soap shelf, multiple measurements and cuts will be required.

Apply a 3/16" bead of adhesive (included in kit) along the corner seam where the corner molding is to be placed. Press corner molding firmly into position. Immediately remove any excess adhesive with a damp cloth. Temporarily secure corner molding to the wall with masking tape. Allow adhesive to cure overnight.

CAULKING

Following instructions on the caulking tube...apply a bead of caulk along the bottom and to edge of the back and side walls. Also make caulk applications to all vertical seams and edges.

CLEANING

Clean your Swanstone bathtub panels as you would any other fine bath fixture, using normal household detergents and cleansers. Just wiping the wall surfaces quickly removes watermarks and residues. Occasional scrubbing with household abrasive cleansers ensures that the original luster is maintained, similar to tile and other permanent type bath fixture materials.

REPAIRING

Use 400 grit sandpaper to remove scratches and gouges in the surface. A Scotchbright pad can be used to blend in the area.