

Hardware Resources Master Catalog

Your source for decorative, organizer, wood and functional products to make your next project beautiful and profitable.



You are now viewing:

Functional



To view the full catalog, click here.

Functional

Functional Hardware

Concealed Hinges

European Hinge Comparison Chart	708-709
900 Series Commercial Grade	710-713
725 Series Heavy Duty	714-717
700 Series Heavy Duty Soft-close	718-721
Mounting Plates for 900, 725, 700 Series	722-723
Hinge & Plate Selection Guide for 900, 725, 700	724-725
500 Series Standard Duty	726-730
Mounting Plates for 500 Series	732-733
Hinge & Plate Selection Guide for 500 Series	734-735
45° Corner Overlay Hinge	736-737
90° Blind Corner Hinge	738-739
105° Pie Corner Hinge	740
130° Pie-cut Corner Hinge	741
Compact Hinge Comparison Chart	744-745
7390 Series Dura-Close® Compact Soft-close NEW	746-747
6390 Series Dura-Close® Compact Hinges NEW	748-749
5390 Series Standard Duty Compact Soft-close	750-751
4390 Series Standard Duty Compact Hinges	752-753
3390 Series Economical Compact Hinges	754-755
22855 Series Dual Pivot Compact Soft-close	756
22855 Series Dual Pivot Compact Hinges	757
22855 Series Compact Hinges for Cabinet Refacing	758
Soft-close Dampers	759
European & Compact Hinge Accessories	760
Hinge Boring Equipment	761
Additional Installation Information	762

Drawer Slides

Undermount Slide Comparison Chart	766-767
USE58-300 Dura-Close® Undermount Slides	768-769
USE58-100 Undermount Slides	770-771
USE34-100 Commercial Grade Undermount	772-773
USE58-50 Standard Duty Undermount Slides	774-775
Undermount Adjustable Release Clips	776-777
Undermount Shelf Bracket NEW	778
Heavy Duty Metal Drawer Box System NEW	780-781
USE Series Soft-Close Metal Drawer Box System	782
Slide and Hinge Installation Tool	783
Ball Bearing Slide Comparison Chart	786-787
303-300 EZ Open Heavy Duty Soft-close	788-789
303FUSFT Heavy Duty Soft-close Ball Bearing	790-791
209FU Series Commercial Grade Ball Bearing	792-793
300FU Series Extra Heavy Duty Ball Bearing	794-795
301FU Series Heavy Duty Ball Bearing	796-797
303FU Series Heavy Duty Ball Bearing	798-799
303-50 Series Standard Duty Ball Bearing	800-801
303FUPT Series Push-to-Open Ball Bearing	802-803
307FU Series Medium Duty Ball Bearing	804-805
Keyboard Slides	806
Slide Mounting Kit	806
Quick Tray Pilaster System	807
2000 Series Economy Epoxy Slides	808-809
5000 Series Epoxy Slides	810-811
9600 Series Premium Epoxy Slides	812
9400/9500 Series Double Captive Epoxy Slides	813
4000 Series Double Captive Epoxy Slides	814

Screw Information	815-816
-------------------	---------

Drive Bits

Magnetic Bit Holders	817
Pozi Drive Screwdriver	817

Hardware Attachment Screws

Flat Head Screws	818-820
Pan Head Screws	821
Oval Head Screws	822
Pan Washer Head Screws	822
Undercut Screws	823
Truss Head Screws	823
Euro Screws	824
Truss Head Machine Screws	824
Break Away Truss Head Machine Screws	824

Cabinet Assembly & Installation Screws

Flat Head Nib Screws	825
Trim Head Screws	826
Face Frame/Pocket Hole Screws	826
Bugle Head Screws	826
Standard Washer Head Screws	827
Large Washer Head Screws	828

Special Application Screws

Confirmat Screws	828
Draw Bolt	828
Connector Screws	828
Hollow Wall Anchor	828
Countersunk Finishing Washer	828
Panel Connectors	829

Shutter Hardware

Non-Mortise Hinges	830-831
Butt Hinges	832
Wrap Around Hinges	833
Louvers and Pins	834
Button Catches	834

Shelf Supports and Accessories

Angled Supports	835
Spoon Supports	836
Standards & Clips	837
Pin Supports	837-838
Plastic Shelf Locks	838

Decorative Hinges

Self-closing Overlay Hinge	839
Self-closing 3/8" Inset Hinge	839
Self-closing Full Wrap Around Hinges	840
Self-closing Partial Wrap Around Hinges	841
Free-swinging Full Wrap Around Hinges	842-843
Free-swinging Partial Wrap Around Hinges	843-844
Institutional Hinges	845-846
1/2 Overlay Knife Hinge NEW	847
Butler Tray Hinge	847
Continuous Piano Hinge	847

Cabinet and Drawer Accessories

False Front Clip	847
Door Bumpers	848
Locks	848
Magnetic Catches	849
Roller Catches	850
Elbow Catches	850
Magnetic Touch Latches	850
Rectangular Strike Plates	850

Brackets and Miscellaneous Hardware

Angled Corner Braces	851
Flat Mending Plates	852
Drawer Adjustment Brackets	852
Plastic Brackets	853
Mirror Hanging Brackets	853

Functional

Commercial Hardware

Hinges		
Institutional Hinges.....	855	
Standards & Brackets		
Medium Duty Standards.....	856-857	
Heavy Duty Standards.....	858-859	
Extra Heavy Duty Standards.....	860-861	
Work Station Brackets.....	862-863	
Grommets		
Cable Grommets.....	864	
Trash Can Grommets.....	865	
Connectors		
Two Piece Panel Connectors.....	866	
Two Piece Connector Bolt.....	867	
Conformat Flat Head Screws.....	867	
Catches		
Roller Catch.....	868	
Magnetic Catch.....	868	
Elbow Catch.....	868	
Touch Latch.....	869	
Strike Plates.....	869	
Cabinet Locks.....	870-871	
Shelf Supports.....	872-873	
Adjustable Plastic Foot.....	874	
Leg Levelers.....	875	
Hanging File Accessories.....	876	
Hanging File Kit.....	877	
Decorative Hardware.....	878	



Hardware Resources believes in quality, integrity, and reliability. We uphold the highest standards of service and responsibility in the industry.

As such, Hardware Resources warrants all functional hardware items against defects in material and workmanship as long as the original consumer purchaser owns the products, if the original consumer purchased the products from an authorized distributor of Hardware Resources. Hardware Resources cannot guarantee the quality or condition of products from distributors who do not agree to meet our high standards, and therefore, no warranty is provided for products from unauthorized sellers.

If the finish of any of these items tarnishes, corrodes, rusts, begins to chip or rub off or has any other defect, Hardware Resources will send to the original purchaser, a new replacement product of the same or comparable style and quality at no charge. If a replacement is no longer available, Hardware Resources will refund to the original purchaser, the current wholesale value of the sink.

This warranty is a warranty of replacement only. Hardware Resources specifically does not warrant removal of the product nor installation of replacement new product. This warranty does not apply when the item has been tampered with, misused, improperly installed, altered from the original form, or damaged through improper cleaning, abuse or accident.

In the unlikely event that a defective functional hardware item is encountered, please contact Customer Service at 800.463.0660. Please be able to provide a brief description and photographs of the defect.

- » "One Stop Shop" for all cabinet manufacturing hardware including hinges, slides, screws, door bumpers, shelf pins, catches and more
- » Third Party Testing to meet or exceed all ANSI/BHMA standards
- » Many products certified by the KCMA and Woodwork Institute
- » Hardware Resources is a member of the following trade organizations:



Testing & Certifications

Functional Hardware

Hardware Resources is committed to providing the highest quality products to our customers, products that give a lifetime of consistent, reliable performance through:

- Extensive field testing with our products in the hands of real customers using them in the most challenging real world applications
- Ensuring that our products meet the required standards set forth by national institutions, such as ANSI and the Woodworking Institute through rigorous third party testing and certification

Throughout our catalog you will see references to various certifications including ANSI/BHMA and the Woodworking Institute (WI). These are some of the most common ratings and their meanings:

For cabinet hinges:

ANSI/BHMA Hinge Grade	Door Weight	Permanent Set Test Load	Cycle Test Rating
Grade 1	40 +/- .5 lb.	160 lbf	100,000 cycles
Grade 2	12 +/- .5 lb.	75 lbf	50,000 cycles
Grade 3	6 +/- .5 lb.	75 lbf	25,000 cycles

For drawer slides:

ANSI/BHMA Slide Grade	Static Load Weight	Cycle Test Rating
Grade 1	75 lb.	50,000
Grade 2	50 lb.	35,000
Grade 3	50 lb.	25,000
1HD-100	100 lb.	50,000

Static Load Rating: non-moving weight test with the specified weight over 24 hours.

Dynamic Load Rating: more robust test which includes a moving weight test with a specified weight over a set number of cycles.

Woodwork Institute certification and what it means:

As a service to members of the Woodwork Institute and the architectural millwork industry in general, the WI certifies and acknowledges products that have been reviewed and confirmed to meet the WI's minimum requirements. These product requirements are established by the Architectural Woodwork Standards and can be found online at <http://woodworkinstitute.com>.



sample hinge certification

European Hinges

Hardware Resources' has a well-rounded selection of hinges to meet just about every application: Face frame/Frameless, Compact/European and Soft-close/Self-close.

- **900 Series** - 110°, 125° and 165° Heavy Duty European Hinges
- **725 Series** - 110°, 125° and 165° European Hinges
- **700 Series** - 90°, 110°, 125° and 165° Soft-close European Hinges
- **500 Series** - 90°, 110°, 125° and 170° European Hinges

800.463.0660
www.HardwareResources.com

hardware
resources[®]

**Commercial Grade European Hinges:
900 Series**

[710]



**Heavy Duty European Hinges:
725 Series**

[714]



**Heavy Duty Soft-close European Hinges:
700 Series**

[718]



**Standard Duty European Hinges:
500 Series**

[726]



Specialty Hinges

[736]



HR Series Comparison

European Hinges



Features
Specs

Series	900 Series
Category	Heavy Duty Commercial
Grade 2 ANSI/BHMA lifecycle	100,000+
Heavy duty: Ideal for larger doors, heavy usage, as well as standard residential applications	✓
Lever-top available: Provides toolless installation & removal	✓
Patented anti-sag stacked linkage: Reduces door sag & provides minimal side-to-side play	✓
Soft-close	
6-Way adjustability: Horizontal, depth & vertical with plate	✓
Overlays available	Full, Half, Inset
Opening angle in degrees	110, 125, 165
Hinge plate options	Heavy Duty Die Cast, Standard Duty Stamped
Compatible plate series	600 Series

HR Series Comparison European Hinges

European
Hinges



725 Series	700 Series	500 Series
Upgraded Heavy Duty	Heavy Duty Soft-close	Standard Duty
50,000+	50,000+	50,000+
✓	✓	
	✓	✓
✓	✓	
	✓	
✓	✓	✓
Full, Half, Inset	Full, Half, Inset	Full, Half, Inset
110, 125, 165	90, 110, 125, 165	90, 110, 125, 170
Heavy Duty Die Cast, Standard Duty Stamped	Heavy Duty Die Cast, Standard Duty Stamped	Heavy Duty Die Cast, Standard Duty Stamped
600 Series	600 Series	400 Series

Commercial Grade European Hinges 900 Series

A heavy duty hinge designed specifically for rugged commercial use in either frameless or face frame applications.

Features

Heavy duty spring and patented linkage system

Grade 2 ANSI/BHMA certified to 2X ANSI 100,000 cycles

Lever-top option available



Opening Angle

110°
125°
165°

US patent #
8,819,897 B2

Specs

110, 125 and 165 degree opening angles

2-stop action

Hinge and plate provide 6-way adjustability

Cold rolled steel with stylish pewter plating

45 mm boring pattern

Compatible with 600 Series mounting plates

Application

Face frame
Frameless

Finish

Pewter
Plating

Adjustment

6 way

Overlay

Full
Half
Inset

Boring Hole Pattern

45 mm

Material

Steel

Packaging

200/
carton

Certification

2X
ANSI
100,000+

Three-dimensional door adjustment

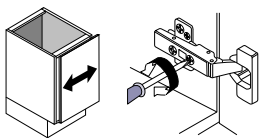
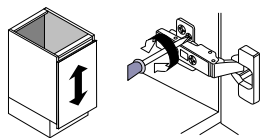
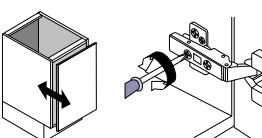
Horizontal adjustment	Vertical adjustment	Depth adjustment
Rotate front screw to increase or decrease door overlay (-2 mm).	Rotate cam screw on mounting plate to adjust door position (-2 mm). On non-cam mounting plates, loosen screws, adjust door and retighten screws.	Rotate rear cam screw to adjust door position (+3 mm, -2 mm).
		

Commercial Grade European Hinges 900 Series

European Hinges



*Full Overlay
0 mm Crank*



*Half Overlay
9 mm Crank*



*Full Inset
15 mm Crank*

APPLICATION

110° Hinges



No Dowels

900.0535.25
200/ctn

900.0536.05
200/ctn

900.0537.05
200/ctn



*Press-in
8 mm Dowels*

900.0181.25
200/ctn

900.0179.25
200/ctn

900.0280.25
200/ctn

125° Hinges



No Dowels

900.0U85.05
200/ctn



*Press-in
8 mm Dowels*

900.0U84.05
200/ctn



*Lever-Top
Dowels*

900.0U94.05
200/ctn

900.0U99.05
200/ctn

Hinges are cam adjustable unless otherwise noted.



90° Restrictor Clip

700.RC
100 pcs/box*

*FULL BOX QUANTITIES ONLY



*Full Overlay
0 mm Crank*

APPLICATION

165° Hinges - Full Overlay



*Press-in
8 mm Dowels*

900.0M73.05
50/ctn



Commercial Grade European Hinges 900 Series

110° Hinges

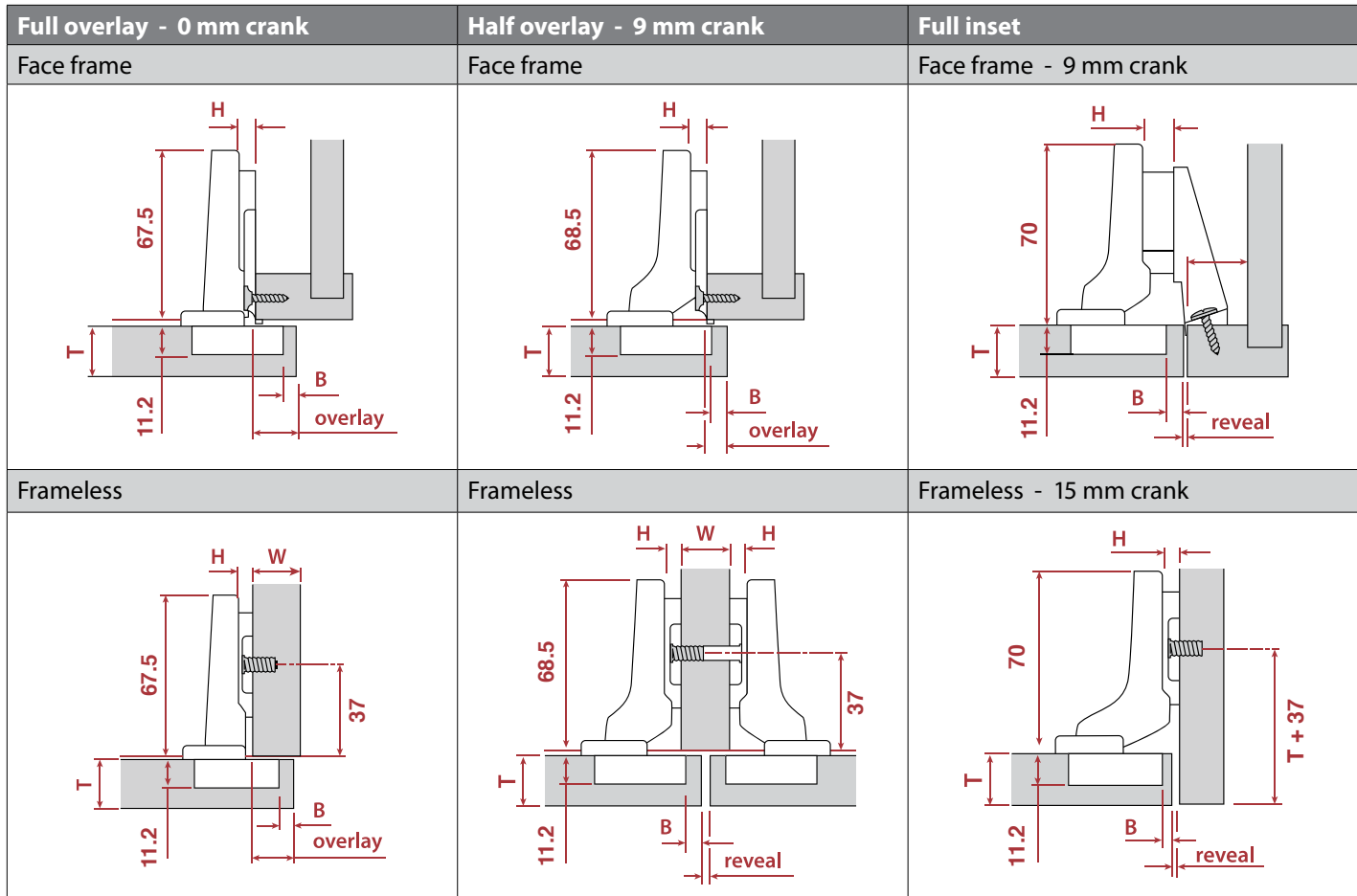

H	Overlay					P	S
0	16	17	18	19	20	8	18.5
2	14	15	16	17	18	10	20.5
3	13	14	15	16	17	11	21.5
6	10	11	12	13	14	14	24.5
9	7	8	9	10	11	17	27.5
	3	4	5	6	7	Fixed distance = 13	
	B = boring distance						

H	Overlay					P	S
0	6	7	8	9	10	17	28
	3	4	5	6	7	Fixed distance = 3	
	B = boring distance						

H	Reveal					W	P	S
0	4	2	-	-	-	16	17	28
	7	5	3	1	-	19		
	10	8	6	4	2	22		
	3	4	5	6	7			
	B = boring distance							

Hinge Length	68.0
Mounting Dimension for Frameless Application*	37
Cup bore depth	11.2

H	Reveal					P	S
0	3	2	1	-	-	26.0	37.5
9	0	-	-	-	-	24.0	33.0
	3	4	5	6	7	Fixed distance = -6	
	B = boring distance						

Abbreviations	
H	= Plate height
P	= Door protrusion
S	= Side arm protrusion
T	= Door thickness
W	= Side panel width

* Inset is "T+" (T=door thickness)

Subject to technical modifications without notice.
Dimensions in millimeters (inch equivalents as noted)

Commercial Grade European Hinges 900 Series

European Hinges

125° Hinges

Full overlay - 0 mm crank

Face frame

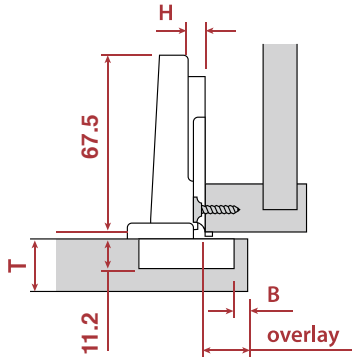

Frameless

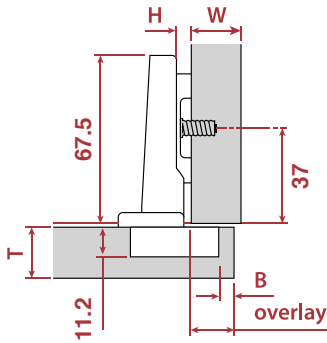

H	Overlay					P	S
0	16	17	18	19	20	4	19.5
2	14	15	16	17	18	6	21.5
3	13	14	15	16	17	7	22.5
6	10	11	12	13	14	10	25.5
9	7	8	9	10	11	13	28.5
	3	4	5	6	7	Fixed distance = 13	
	B = boring distance						

Hinge Length	68
Mounting Dimension for Frameless Application*	37
Cup bore depth	11.2

* Inset is "T+" (T=door thickness)

165° Hinges

Full overlay - 0 mm crank

Face frame

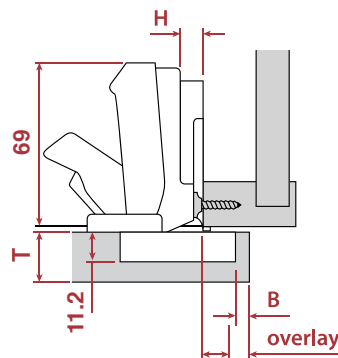

Frameless

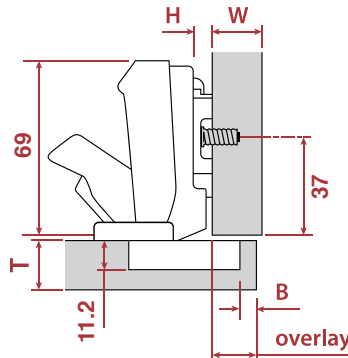

H	Overlay					P	S
0	17	18	19	20	21	-4	58
2	15	16	17	18	19	-2	60
3	14	15	16	17	18	-1	61
6	11	12	13	14	15	2	64
9	8	9	10	11	12	5	67
	3	4	5	6	7	Fixed distance = 14	
	B = boring distance						

Hinge Length	69
Mounting Dimension for Frameless Application*	37
Cup bore depth	11.2

* Inset is "T+" (T=door thickness)

Thick door application

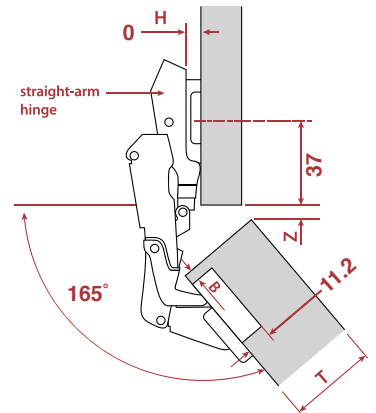

Z=Gap				
28	25	22	18	15
25	29	32	35	38
T = door thickness				

Twin door application

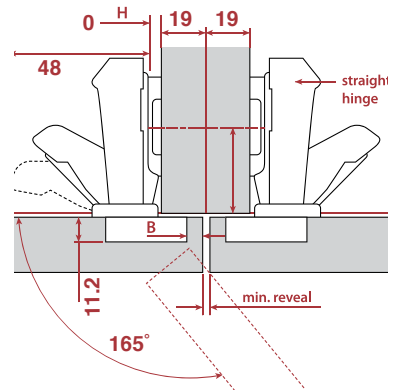

Minimum reveal table					S
0	0	0	14	17	66
19	22	25	29	32	
T = door thickness					

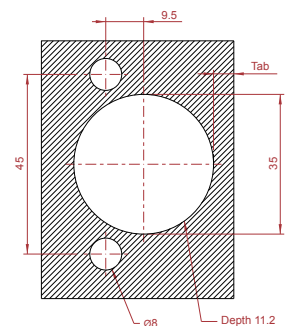

Heavy Duty European Hinges 725 Series

An upgrade to Hardware Resources' standard grade European hinge, the 725 series is perfect for those looking for a premium self-close hinge without the premium price.



Features

Heavy duty spring and patented linkage system

Grade 2 ANSI/BHMA certified to ANSI 50,000 cycles

Lever-top option available

Opening Angle

110°
125°
165°

US patent #
8,819,897 B2

Specs

110, 125 and 165 degree opening angles

2-stop action

Hinge and plate provide 6-way adjustability

Cold rolled steel with nickel plating

45 mm boring pattern

Compatible with 600 Series mounting plates

Application

Face frame
Frameless

Finish

Nickel
Plating

Adjustment

6 way

Overlay

Full
Half
Inset

Boring Hole Pattern

45 mm

Material

Steel

Packaging

200/
carton

Certification

ANSI
50,000+

Three-dimensional door adjustment

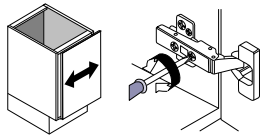
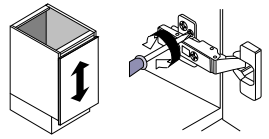
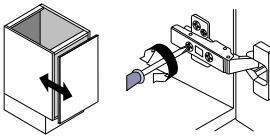
Horizontal adjustment	Vertical adjustment	Depth adjustment
Rotate front screw to increase or decrease door overlay (-2 mm).	Rotate cam screw on mounting plate to adjust door position (-2 mm). On non-cam mounting plates, loosen screws, adjust door and retighten screws.	Rotate rear cam screw to adjust door position (+3 mm, -2 mm).
		

Heavy Duty European Hinges 725 Series

European
Hinges



Full Overlay
0 mm Crank



Half Overlay
9 mm Crank



Full Inset
15 mm Crank

APPLICATION

110° Hinges



No Dowels

725.0535.25
(cam adjust)
200/ctn

NEW
725.0534.25
(screw adjust)
200/ctn

725.0536.25
200/ctn

725.0537.25
200/ctn



Press-in
8 mm Dowels

725.0181.25
(cam adjust)
200/ctn

NEW
725.0171.25
(screw adjust)
200/ctn

725.0179.25
200/ctn

725.0280.25
200/ctn

125° Hinges



No Dowels

725.0U85.05
200/ctn



Press-in
8 mm Dowels

725.0U84.05
200/ctn

Hinges are cam adjustable unless otherwise noted.



90° Restrictor Clip

700.RC
100 pcs/box*

*FULL BOX QUANTITIES ONLY



Full Overlay
0 mm Crank

APPLICATION

165° Hinges - Full Overlay



Press-in
8 mm Dowels

725.0M73.05
50/ctn

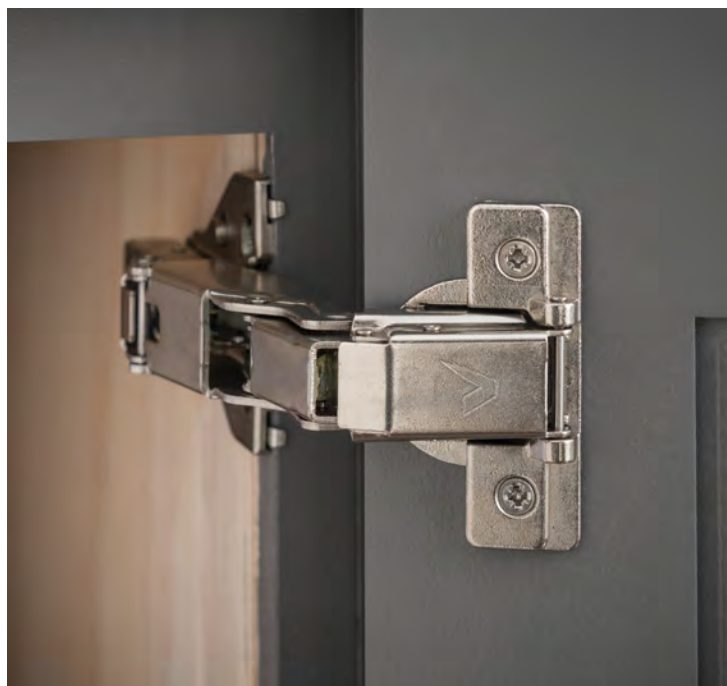

Heavy Duty European Hinges 725 Series

110° Hinges

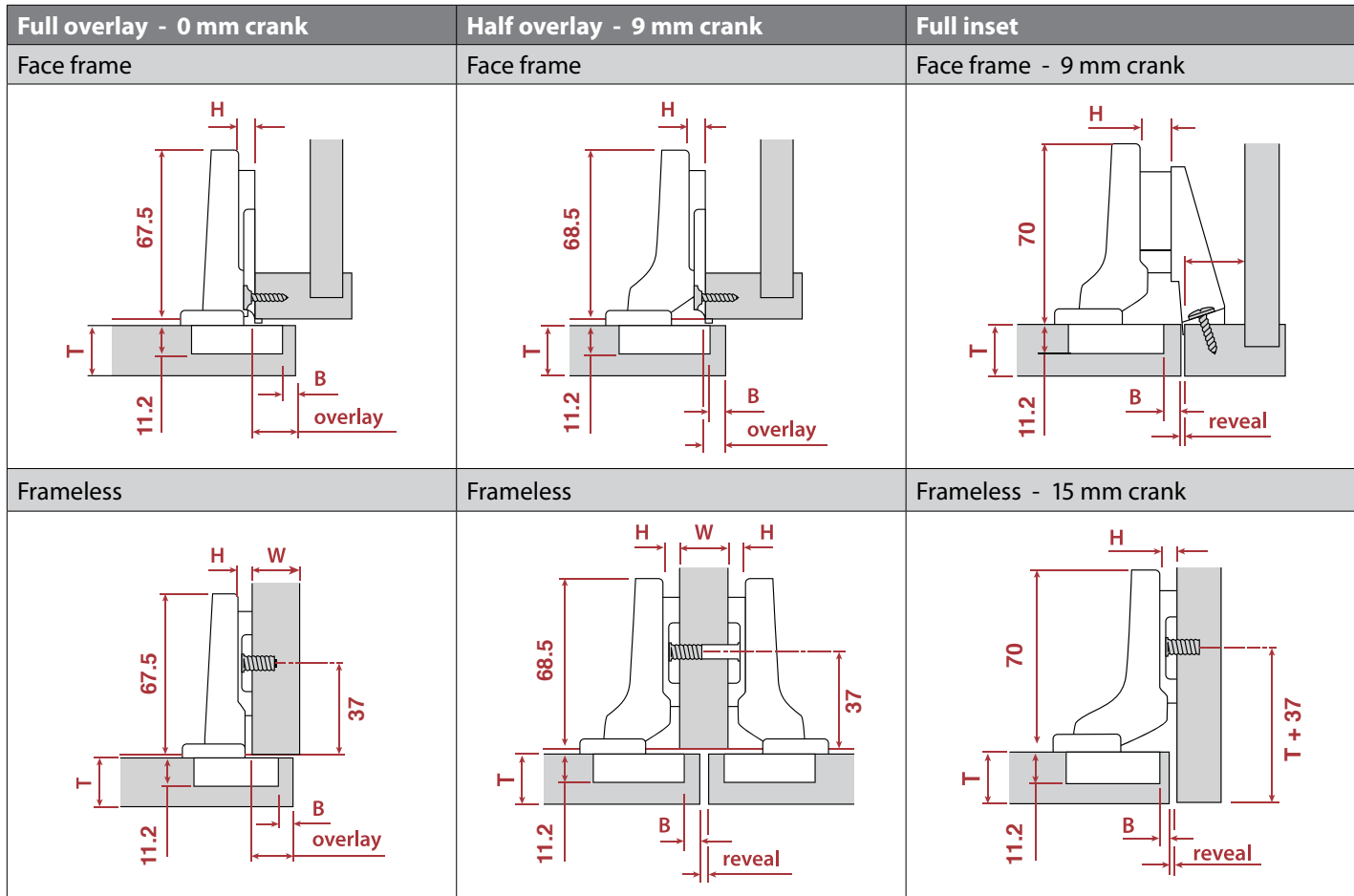

H	Overlay					P	S
0	16	17	18	19	20	8	18.5
2	14	15	16	17	18	10	20.5
3	13	14	15	16	17	11	21.5
6	10	11	12	13	14	14	24.5
9	7	8	9	10	11	17	27.5
	3	4	5	6	7	Fixed distance = 13	
	B = boring distance						

H	Overlay					P	S
0	6	7	8	9	10	17	28
	3	4	5	6	7	Fixed distance = 3	
	B = boring distance						

H	Reveal					W	P	S
0	4	2	-	-	-	16	17	28
	7	5	3	1	-	19		
	10	8	6	4	2	22		
	3	4	5	6	7			
	B = boring distance							

Hinge Length	68.0
Mounting Dimension for Frameless Application*	37
Cup bore depth	11.2

H	Reveal					P	S
0	3	2	1	-	-	26.0	37.5
9	0	-	-	-	-	24.0	33.0
	3	4	5	6	7	Fixed distance = -6	
	B = boring distance						

Abbreviations	
H	= Plate height
P	= Door protrusion
S	= Side arm protrusion
T	= Door thickness
W	= Side panel width

* Inset is "T+" (T=door thickness)

Subject to technical modifications without notice.
Dimensions in millimeters (inch equivalents as noted)

Heavy Duty European Hinges 725 Series

European Hinges

125° Hinges

Full overlay - 0 mm crank

Face frame

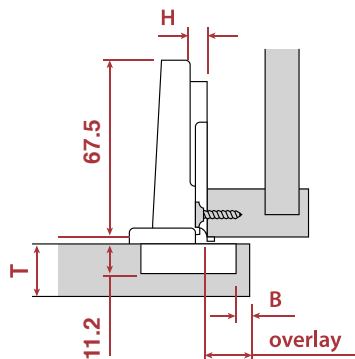

Frameless

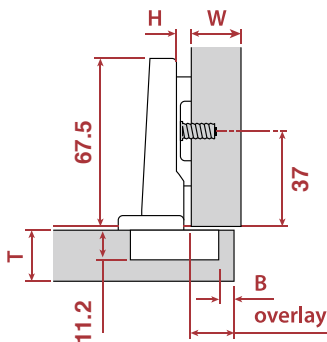

H	Overlay					P	S
0	16	17	18	19	20	4	19.5
2	14	15	16	17	18	6	21.5
3	13	14	15	16	17	7	22.5
6	10	11	12	13	14	10	25.5
9	7	8	9	10	11	13	28.5
	3	4	5	6	7	Fixed distance = 13	
	B = boring distance						

Hinge Length	68
Mounting Dimension for Frameless Application*	37
Cup bore depth	11.2

* Inset is "T+" (T=door thickness)

165° Hinges

Full overlay - 0 mm crank

Face frame

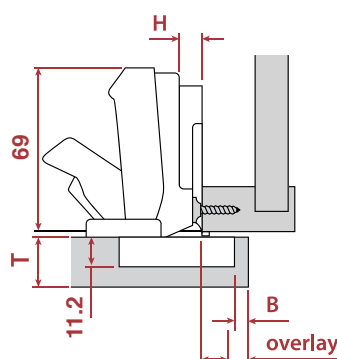

Frameless

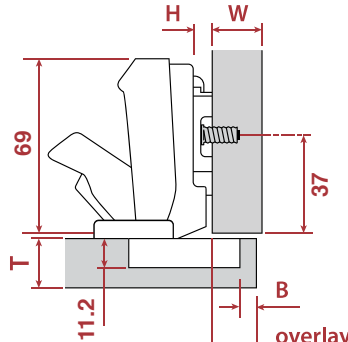

H	Overlay					P	S
0	17	18	19	20	21	-4	58
2	15	16	17	18	19	-2	60
3	14	15	16	17	18	-1	61
6	11	12	13	14	15	2	64
9	8	9	10	11	12	5	67
	3	4	5	6	7	Fixed distance = 14	
	B = boring distance						

Hinge Length	69
Mounting Dimension for Frameless Application*	37
Cup bore depth	11.2

* Inset is "T+" (T=door thickness)

Thick door application

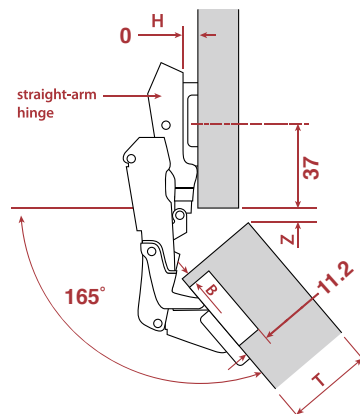

Z=Gap

28	25	22	18	15
25	29	32	35	38
T = door thickness				

Twin door application

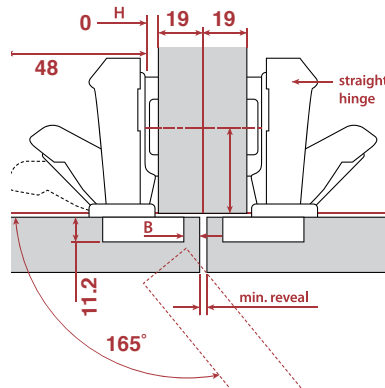

Minimum reveal table

Minimum reveal table					S
0	0	0	14	17	66
19	22	25	29	32	
T = door thickness					

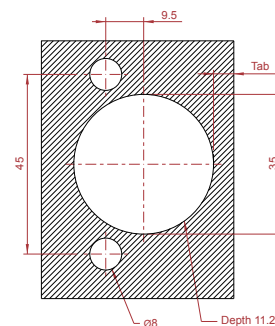

Subject to technical modifications without notice.
Dimensions in millimeters (inch equivalents as noted)

Heavy Duty Soft-close European Hinges 700 Series

A soft-close European hinge ideal for a wide range of residential and commercial applications. Face frame and frameless compatible.

Features

- Heavy duty spring and patented linkage system
- Grade 2 ANSI/BHMA certified to ANSI 50,000 cycles
- All metal concealed damper provides a life time of worry-free use

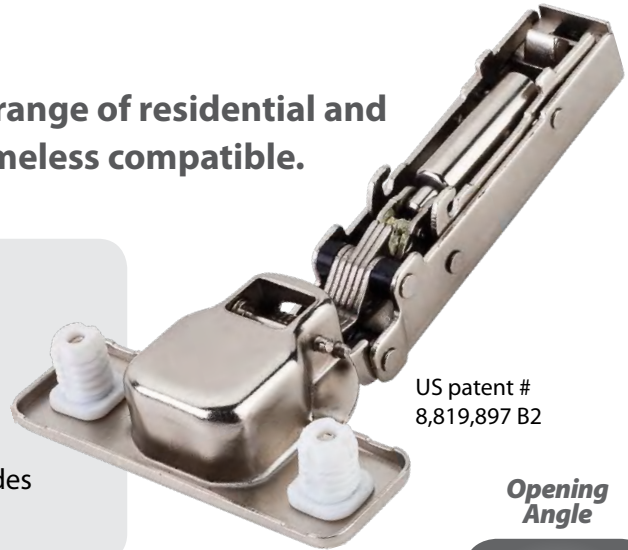

US patent #
8,819,897 B2

Opening Angle



Specs

- 90, 110, 125 and 165 degree opening angles
- 2-stop action
- Hinge and plate provide 6-way adjustability
- Cold rolled steel with nickel plating
- 45 mm boring pattern
- Compatible with 600 Series mounting plates

Application

Face frame
Frameless

Finish

Nickel
Plating

Adjustment

6 way

Overlay

Full
Half
Inset

Boring Hole Pattern



Material

Steel

Packaging

200/
carton

Certification

ANSI
50,000+

Three-dimensional door adjustment

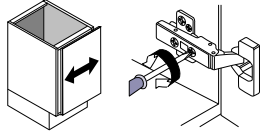
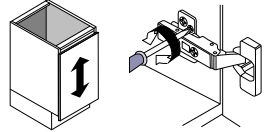
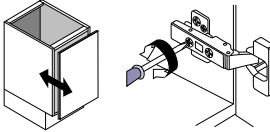
Horizontal adjustment	Vertical adjustment	Depth adjustment
Rotate front screw to increase or decrease door overlay (-2 mm).	Rotate cam screw on mounting plate to adjust door position (-2 mm). On non-cam mounting plates, loosen screws, adjust door and retighten screws.	Rotate rear cam screw to adjust door position (+3 mm, -2 mm).
		

Heavy Duty Soft-close European Hinges 700 Series

European
Hinges



Full Overlay
0 mm Crank



Half Overlay
9 mm Crank



Full Inset
15 mm Crank

APPLICATION

90° Hinges - Restricted



Press-in
8 mm Dowels

700.0161.25
200/ctn

110° Hinges



No Dowels

700.0535.25
(cam adjust)
200/ctn

700.0534.25
(screw adjust)
200/ctn

700.0536.25
200/ctn

700.0537.25
200/ctn



Press-in
8 mm Dowels

700.0181.25
(cam adjust)
200/ctn

700.0171.25
(screw adjust)
200/ctn

700.0179.25
200/ctn

700.0280.25
200/ctn

125° Hinges



No Dowels

700.0U85.05
200/ctn



Press-in
8 mm Dowels

700.0U84.05
200/ctn



Easy-Fix
Dowels
with Cover

700.0U86.05
200/ctn



Lever-Top
Dowels

700.0U94.05
200/ctn

700.0U99.05
200/ctn

Hinges are cam adjustable unless otherwise noted.



Full Overlay
0 mm Crank

APPLICATION

165° Hinges - Full Overlay



Press-in
8 mm Dowels

700.0M73.05
50/ctn



90° Restrictor Clip

700.RC
100 pcs/box*

*FULL BOX QUANTITIES ONLY

Heavy Duty Soft-close European Hinges 700 Series

90° & 110° Hinges

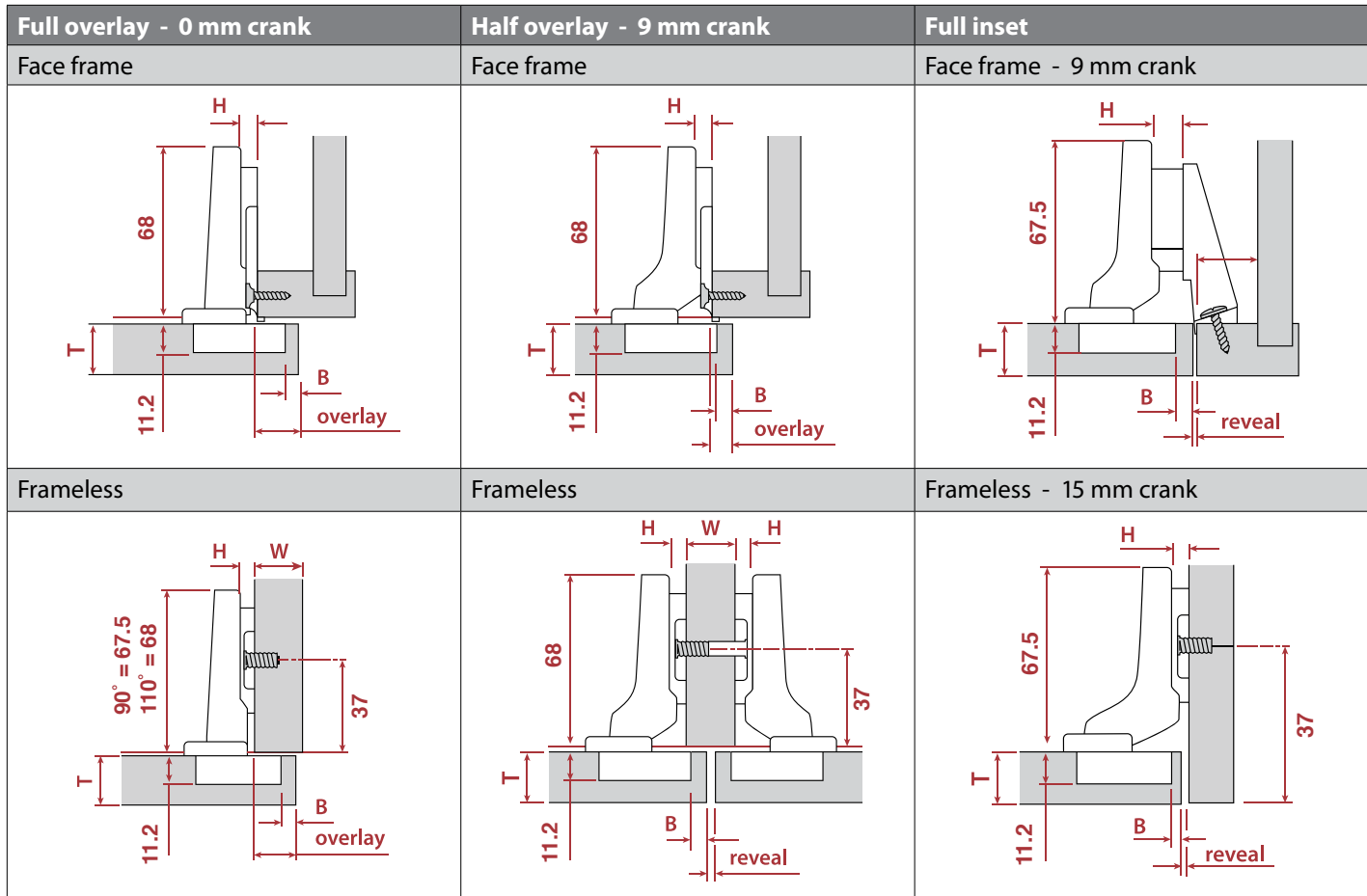

H	Overlay - 90°					P	S
0	16	17	18	19	20	4.5	19
2	14	15	16	17	18	6.5	21
3	13	14	15	16	17	7.5	22
6	10	11	12	13	14	10.5	25
9	7	8	9	10	11	13.5	28
	3	4	5	6	7	Fixed distance = 13	
	B = boring distance						

H	Overlay - 110°					P	S
0	16	17	18	19	20	7	19
2	14	15	16	17	18	9	21
3	13	14	15	16	17	10	22
6	10	11	12	13	14	13	25
9	7	8	9	10	11	16	28
	3	4	5	6	7	Fixed distance = 13	
	B = boring distance						

H	Overlay					P	S
0	6	7	8	9	10	17	28
	3	4	5	6	7	Fixed distance = 3	
	B = boring distance						

H	Reveal					W	P	S
0	4	2	-	-	-	16	17	28
	7	5	3	1	-	19		
	10	8	6	4	2	22		
	3	4	5	6	7			
	B = boring distance							

Hinge Length	68 (67.5 inset)
Mounting Dimension for Frameless Application*	37
Cup bore depth	11.2

* Inset is "T+" (T=door thickness)

H	Reveal					P	S
0	2.5	1.5	0.5	-	-	25.5	37
9	1	-	-	-	-	0	37
	3	4	5	6	7	Fixed distance = -5.5	
	B = boring distance						

Abbreviations	
H	= Plate height
P	= Door protrusion
S	= Side arm protrusion
T	= Door thickness
W	= Side panel width

Subject to technical modifications without notice. Dimensions in millimeters (inch equivalents as noted)

Heavy Duty Soft-close European Hinges 700 Series

European Hinges

125° Hinges

Full overlay - 0 mm crank

Face frame

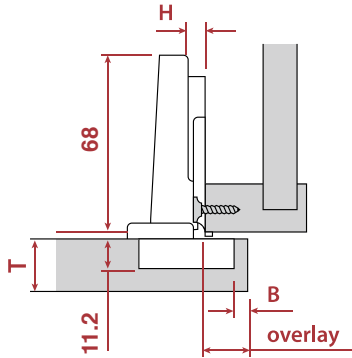

Frameless

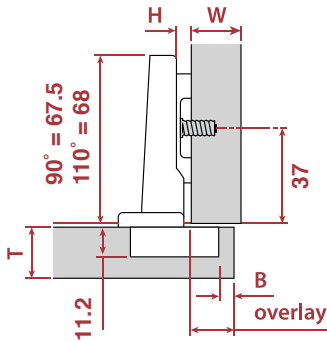

H	Overlay					P	S
0	16	17	18	19	20	8	19
2	14	15	16	17	18	10	21
3	13	14	15	16	17	11	22
6	10	11	12	13	14	14	25
9	7	8	9	10	11	17	28
	3	4	5	6	7	Fixed distance = 13	
	B = boring distance						

Hinge Length	68
Mounting Dimension for Frameless Application*	37
Cup bore depth	11.2

* Inset is "T+" (T=door thickness)

165° Hinges

Full overlay - 0 mm crank

Face frame

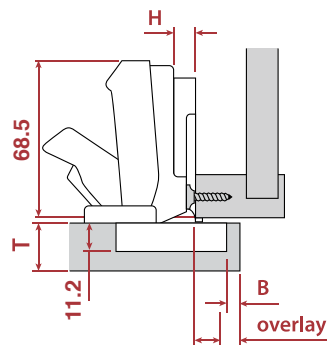

Frameless

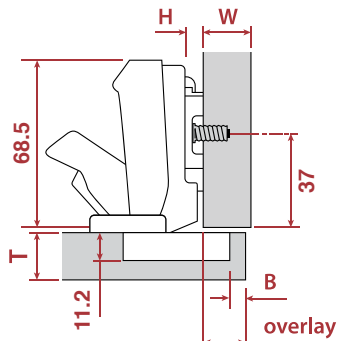

H	Overlay					P	S
0	15	16	17	18	19	-5	58.5
2	13	14	15	16	17	-3	60.5
3	12	13	14	15	16	-2	61.5
6	9	10	11	12	13	1	64.5
9	6	7	8	9	10	4	67.5
	3	4	5	6	7	Fixed distance = 12	
	B = boring distance						

Hinge Length	68.5
Mounting Dimension for Frameless Application*	37
Cup bore depth	11.2

* Inset is "T+" (T=door thickness)

Thick door application

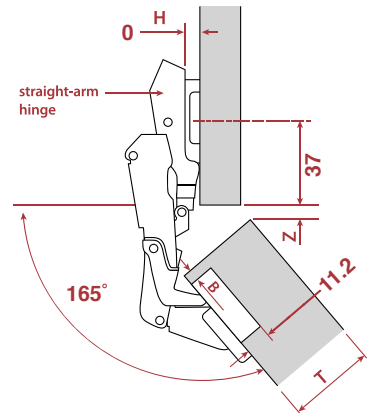

Z=Gap

28	25	22	18	15
25	29	32	35	38
T = door thickness				

Twin door application

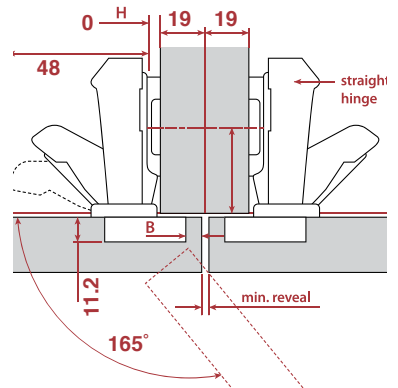





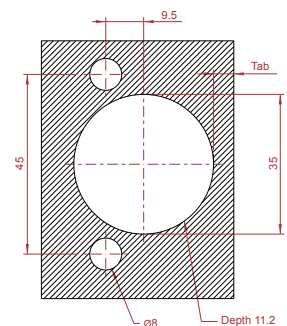





Minimum reveal table

Minimum reveal table					S
0	0	0	14	17	66
19	22	25	29	32	
T = door thickness					



Subject to technical modifications without notice.
Dimensions in millimeters (inch equivalents as noted)

Mounting Plates for 700, 725 and 900 Series Hinges

Frameless Cabinetry		0 mm	2 mm	9 mm
Heavy Duty Zinc Die Cast Cam Adjustable Plates				
	<p>3-hole mounting for added stability and secure attachment Material: Zinc die cast, nickel plated Preassembled with 6.3 mm x 15 mm Euro system screws Height adjustment: +/- 3 mm</p>	600.0P30.05 (screw adjust) 200/ctn	600.0P32.05 (screw adjust) 200/ctn	
	<p>3-hole mounting for added stability and secure attachment Material: Zinc die cast, nickel plated Use #6 x 5/8" flat head wood screws for attachment Height adjustment: +/- 3 mm</p>	600.0R30.0 (screw adjust) 200/ctn	600.0R32.05 (screw adjust) 200/ctn	
	<p>Heavy Duty Material: Zinc die cast, nickel plated Preassembled with 6.3 mm x 15 mm Euro system screws Cam height adjustment: +/- 2 mm</p>	600.0P72.05 (cam adjust) 200/ctn	600.0P74.05 (cam adjust) 200/ctn	600.0R29.05 (cam adjust) 200/ctn
	<p>Heavy Duty Material: Zinc die cast, nickel plated Sold without screws Use #6 x 5/8" flat head wood screws for attachment Cam height adjustment: +/- 2 mm</p>	600.0R23.05 (cam adjust) 200/ctn	600.0R25.05 (cam adjust) 200/ctn	600.0P29.05 (cam adjust) 200/ctn
Standard Duty Steel Cam Adjustable Plates				
	<p>Material: Cold rolled steel, nickel plated Preassembled with 6.3 mm x 15 mm Euro system screws Cam height adjustment: +/- 2 mm</p>	600.0P71.05 200/ctn	600.0P73.05 200/ctn	
	<p>Material: Cold rolled steel, nickel plated Sold without screws Use #6 x 5/8" flat head wood screws for attachment Cam height adjustment: +/- 2 mm</p>	600.0R22.05 200/ctn	600.0R24.05 200/ctn	
Standard Duty Steel Non-Cam Adjustable Plates				
	<p>Material: Cold rolled steel, nickel plated Preassembled with 6.3 mm x 15 mm Euro system screws Height adjustment: +/- 3 mm</p>	600.0118.05 200/ctn	600.0119.05 200/ctn	
	<p>Material: Cold rolled steel, nickel plated Sold without screws Use #6 x 5/8" flat head wood screws for attachment Height adjustment: +/- 3 mm</p>	600.1233.05 200/ctn	600.1234.05 200/ctn	
	<p>Dowels provide a stronger holding force for the hinge and plate Material: Cold rolled steel, nickel plated Preassembled with wood screws 5 mm expansion dowels Height adjustment: +/- 3 mm</p>	600.2118.05 200/ctn	600.2119.05 200/ctn	
	<p>Used for back-to-back hinge installation in 19 mm material Material: Cold rolled steel, nickel plated Preassembled with 6.3 mm x 10 mm shortened Euro system screws Height adjustment: +/- 3 mm</p>	600.3118.05 200/ctn	600.3119.05 200/ctn	

Mounting Plates for 700, 725 and 900 Series Hinges

European
Hinges

Face Frame Cabinetry

0 mm

3 mm

6 mm

9 mm

Heavy Duty Zinc Die Cast Cam Adjustable Plates



Material: Zinc die cast, nickel plated
Sold without screws
Use #6 x 5/8" flat head wood screws for attachment
Cam height adjustment: +/- 3.5 mm

600.3553.65
200/ctn

600.3554.65
200/ctn

600.3555.65
200/ctn



Material: Zinc die cast, nickel plated
Sold without screws
Use #6 x 5/8" flat head wood screws for attachment
Designed for inset applications using 9 mm crank hinges
Cam height adjustment: +/- 3.5 mm

600.3458.65
200/ctn

Heavy Duty Zinc Die Cast Non-Cam Adjustable Plates



Material: Zinc die cast, nickel plated
Sold without screws
Use #6 x 5/8" flat head wood screws for attachment
Height adjustment: +/- 3.5 mm

NEW
600.3454.65
200/ctn



Material: Zinc die cast, nickel plated
Sold without screws
Use #6 x 5/8" flat head wood screws for attachment
Wrap around designed for MDF/plywood face frames
where 4 screws are needed to secure the plate and
prevent screw pull out
Height adjustment: +/- 3.5 mm

600.3459.65
200/ctn

Standard Duty Steel Non-Cam Adjustable Plates



Material: Stamped steel, nickel plated
Sold without screws
Use #6 x 5/8" flat head wood screws for attachment
Height adjustment: +/- 3.5 mm

600.3456.65
200/ctn

600.3457.65
200/ctn

Hinge & Plate Selection Guide for 700, 725 and 900 Series Hinges

Frameless Cabinetry										
Full Overlay					Half Overlay					
Hinge / 0 Crank	Dowel	Adj	Plate / 0 mm	Mat.	Hinge / 9 Crank	Dowel	Adj	Plate / 0 mm	Mat.	
90° 700.0161.25 SC	Press-in	Cam	600.1233.05	Steel	110° 700.0536.25 SC	None	Cam	600.1233.05	Steel	
110° 700.0535.25 SC	None	Cam	600.0118.05 Euro	Steel	110° 700.0179.25 SC	Press-in	Cam	600.0118.05 Euro	Steel	
110° 700.0534.25 SC	None	Screw	600.2118.05	Steel	110° 900.0536.05 HD	None	Cam	600.2118.05	Steel	
110° 700.0181.25 SC	Press-in	Cam	600.3118.05 Euro	Steel	110° 725.0536.25	None	Cam	600.3118.05 Euro	Steel	
110° 700.0171.25 SC	Press-In	Screw	600.0R22.05 Cam	Zinc	110° 725.0179.25	Press-in	Cam	600.0R22.05 Cam	Zinc	
110° 725.0535.25	None	Cam	600.0R23.05 Cam	Zinc	110° 900.0179.25 HD	Press-in	Cam	600.0R23.05 Cam	Zinc	
110° 725.0534.25	None	Screw	600.0P71.05 Cam/Euro	Zinc	125° 700.0U99.05	Lever	Cam	600.0P71.05 Cam/Euro	Zinc	
110° 725.0181.25	Press-in	Cam	600.0P72.05 Cam/Euro	Zinc				600.0P72.05 Cam/Euro	Zinc	
110° 725.0171.25	Press-In	Screw	600.0P30.05 3-Hole	Zinc				600.0P30.05 3-Hole	Zinc	
110° 900.0535.05 HD	None	Cam	600.0R30.05 3-Hole	Zinc				600.0R30.05 3-Hole	Zinc	
110° 900.0181.25 HD	Press-in	Cam						600.3454.65 110	Zinc	
125° 700.0U85.05 SC	None	Cam								
125° 700.0U84.05 SC	Press-in	Cam								
125° 700.0U86.05 SC	Easy-Fix	Cam								
125° 700.0U94.05 SC	Lever	Cam								
125° 725.0U84.05	Press-in	Cam								
125° 725.0U85.05	None	Cam								
125° 900.0U85.05 HD	None	Cam								
125° 900.0U84.05 HD	Press-in	Cam								
125° 900.0U94.05 HD	Lever	Cam								
165° 700.0M73.05 SC	Press-in	Cam								
165° 900.0M73.05 HD	Press-in	Cam								
170° 725.0M73.05	Press-in	Cam								
Inset					45 Degree					
Hinge / 15 Crank	Dowel	Adj	Plate / 0 mm	Mat.	Hinge / 18 Crank	Dowel	Adj	Plate / 0 mm	Mat.	
110° 700.0537.25 SC	None	Cam	600.1233.05	Steel	105° 700.0N20.05 SC	Press-in	Screw	600.1233.05	Steel	
110° 700.0280.25 SC	Press-in	Cam	600.0118.05 Euro	Steel				600.0118.05 Euro	Steel	
110° 725.0537.25	None	Cam	600.2118.05	Steel				600.2118.05	Steel	
110° 725.0280.25	Press-in	Cam	600.3118.05 Euro	Steel				600.3118.05 Euro	Steel	
110° 900.0537.05 HD	None	Cam	600.0R22.05 Cam	Zinc				600.0R22.05 Cam	Zinc	
110° 900.0280.25 HD	Press-in	Cam	600.0R23.05 Cam	Zinc				600.0R23.05 Cam	Zinc	
			600.0P71.05 Cam/Euro	Zinc				600.0P71.05 Cam/Euro	Zinc	
			600.0P72.05 Cam/Euro	Zinc				600.0P72.05 Cam/Euro	Zinc	
			600.0P30.05 3-Hole	Zinc				600.0P30.05 3-Hole	Zinc	
			600.0R30.05 3-Hole	Zinc				600.0R30.05 3-Hole	Zinc	
					90 Degree Blind Corner (Inset application/no overlay)					
Hinge / 15 Crank	Dowel	Adj	Plate / 0 mm	Mat.	Hinge / 18 Crank	Dowel	Adj	Plate / 0 mm	Mat.	
					105° 700.0N24.05 SC	Press-in	Screw	600.1233.05	Steel	
								600.0118.05 Euro	Steel	
								600.2118.05	Steel	
								600.3118.05 Euro	Steel	
								600.0R22.05 Cam	Zinc	
								600.0R23.05 Cam	Zinc	
								600.0P71.05 Cam/Euro	Zinc	
								600.0P72.05 Cam/Euro	Zinc	
								600.0P30.05 3-Hole	Zinc	
								600.0R30.05 3-Hole	Zinc	

Hinge & Plate Selection Guide for 700, 725 and 900 Series Hinges

European
Hinges

Face Frame Cabinetry									
3/4" Overlay					1/2" Overlay				
Hinge /0 Crank	Dowel	Adj	Plate /0 mm	Mat.	Hinge /0 Crank	Dowel	Adj	Plate /3 mm	Mat.
90° 700.0161.25 SC	Press-in	Cam	600.3456.65	Steel	90° 700.0161.25 SC	Press-in	Cam	600.3457.65	Steel
110° 700.0535.25 SC	None	Cam	600.3553.65 Cam	Zinc	110° 700.0535.25 SC	None	Cam	600.3554.65 Cam	Zinc
110° 700.0181.25 SC	Press-in	Cam	600.3453.65 110	Zinc	110° 700.0181.25 SC	Press-in	Cam	600.3459.65 Wrap Around	Zinc
110° 725.0534.25	None	Screw			110° 725.0534.25	None	Screw	600.3454.65 110	Zinc
110° 725.0535.25	None	Cam			110° 725.0535.25	None	Cam		
110° 725.0171.25	Press-in	Screw			110° 725.0171.25	Press-in	Screw		
110° 725.0181.25	Press-in	Cam			110° 725.0181.25	Press-in	Cam		
110° 900.0535.05 HD	None	Cam			110° 900.0535.05 HD	None	Cam		
110° 900.0181.25 HD	Press-in	Cam			110° 900.0181.25 HD	Press-in	Cam		
125° 700.0U85.05 SC	None	Cam			125° 700.0U85.05 SC	None	Cam		
125° 700.0U84.05 SC	Press-in	Cam			125° 700.0U84.05 SC	Press-in	Cam		
125° 700.0U86.05 SC	Easy-Fix	Cam			125° 700.0U86.05 SC	Easy-Fix	Cam		
125° 700.0U94.05 SC	Lever	Cam			125° 700.0U94.05 SC	Lever	Cam		
125° 725.0U84.05	Press-in	Cam			125° 725.0U84.05	Press-in	Cam		
125° 725.0U85.05	None	Cam			125° 725.0U85.05	None	Cam		
125° 900.0U85.05 HD	None	Cam			125° 900.0U85.05 HD	None	Cam		
125° 900.0U84.05 HD	Press-in	Cam			125° 900.0U84.05 HD	Press-in	Cam		
125° 900.0U94.05 HD	Lever	Cam			125° 900.0U94.05 HD	Lever	Cam		
165° 700.0M73.05 SC	Press-in	Cam			165° 700.0M73.05 SC	Press-in	Cam		
165° 900.0M73.05 HD	Press-in	Cam			165° 900.0M73.05 HD	Press-in	Cam		
170° 725.0M73.05	Press-in	Cam			170° 725.0M73.05	Press-in	Cam		

3/8" Overlay					Inset				
Hinge /9 Crank	Dowel	Adj	Plate /0 mm	Mat.	Hinge /9 Crank	Dowel	Adj	Plate /9 mm Inset	Mat.
110° 700.0536.25 SC	None	Cam	600.3456.65	Steel	110° 700.0536.25 SC	None	Cam	600.3458.65 Cam	Zinc
110° 700.0179.25 SC	Press-in	Cam	600.3553.65 Cam	Zinc	110° 700.0179.25 SC	Press-in	Cam	600.3454.65 110	Zinc
110° 725.0536.25	None	Cam	600.3453.65 110	Zinc	110° 725.0536.25	None	Cam		
110° 725.0179.25	Press-in	Cam			110° 725.0179.25	Press-in	Cam		
110° 900.0536.05 HD	None	Cam			110° 900.0536.05 HD	None	Cam		
110° 900.0179.25 HD	Press-in	Cam			110° 900.0179.25 HD	Press-in	Cam		
125° 700.0U99.05	Lever	Cam							

Standard Duty European Hinges 500 Series

Hardware Resources' tried and true standard duty European hinge that provides performance you need with a price you can't resist.



Features

- Grade 2 ANSI/BHMA certified to ANSI 50,000 cycles
- Lever-top option available

Opening Angle



90° 125°
110° 170°

Specs

- 90, 110, 125 and 170 degree opening angles
- 1-stop action
- Hinge and plate provide 6-way adjustability
- Cold rolled steel with nickel plating
- 45 mm boring pattern
- Compatible with 400 Series mounting plates

Application

Face frame
Frameless

Finish

Nickel Plating

Adjustment

6 way

Overlay

Full
Half
Inset

Boring Hole Pattern

45 mm

Material

Steel

Three-dimensional door adjustment

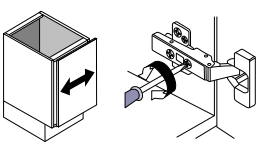
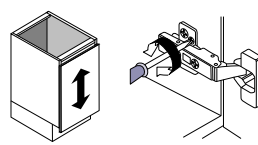
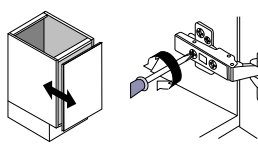
Horizontal adjustment	Vertical adjustment	Depth adjustment
Rotate front screw to increase or decrease door overlay (-2 mm).	Rotate cam screw on mounting plate to adjust door position (-2 mm). On non-cam mounting plates, loosen screws, adjust door and retighten screws.	Rotate rear cam screw to adjust door position (+3 mm, -2 mm).
		

Packaging

200/
carton

Certification

ANSI
50,000+



Standard Duty European Hinges 500 Series

European
Hinges



*Full Overlay
0 mm Crank*



*Half Overlay
9 mm Crank*



*Full Inset
15 mm Crank*

APPLICATION

90° Hinges - Restricted



*Press-in
8 mm Dowels*

500.0161.05
200/ctn

110° Hinges



No Dowels

500.0535.05 (cam adjust)
200/ctn 500.0534.05 (screw adjust)
200/ctn

500.0536.05
200/ctn

500.0537.05
200/ctn



*Press-in
8 mm Dowels*

500.0181.05 (cam adjust)
200/ctn 500.0171.05 (screw adjust)
200/ctn

500.0179.05 (cam adjust)
200/ctn 500.0279.05 (screw adjust)
200/ctn

500.0280.05
200/ctn



*Easy-Fix
Dowels*

500.0186.05
200/ctn

110° Free-Swinging Hinges (Non-self-closing)



*Press-in
8 mm Dowels*

500.0141.05
200/ctn

125° Hinges



No Dowels

500.0U85.05
200/ctn



*Press-in
8 mm Dowels*

500.0U84.05
200/ctn



*Easy-Fix
Dowels*

500.0U86.05
200/ctn



*Lever-Top
Dowels*

500.0U94.05
200/ctn

500.0U99.05
200/ctn



APPLICATION *Full Overlay
0 mm Crank*

170° Hinges - Full Overlay



*Press-in
8 mm Dowels* 500.0M73.05
50/ctn

Hinges are cam adjustable unless otherwise noted.



90° Restrictor Clip 500.RC
100 pcs/box*

*FULL BOX QUANTITIES ONLY

Standard Duty European Hinges 500 Series

90° & 110° Hinges

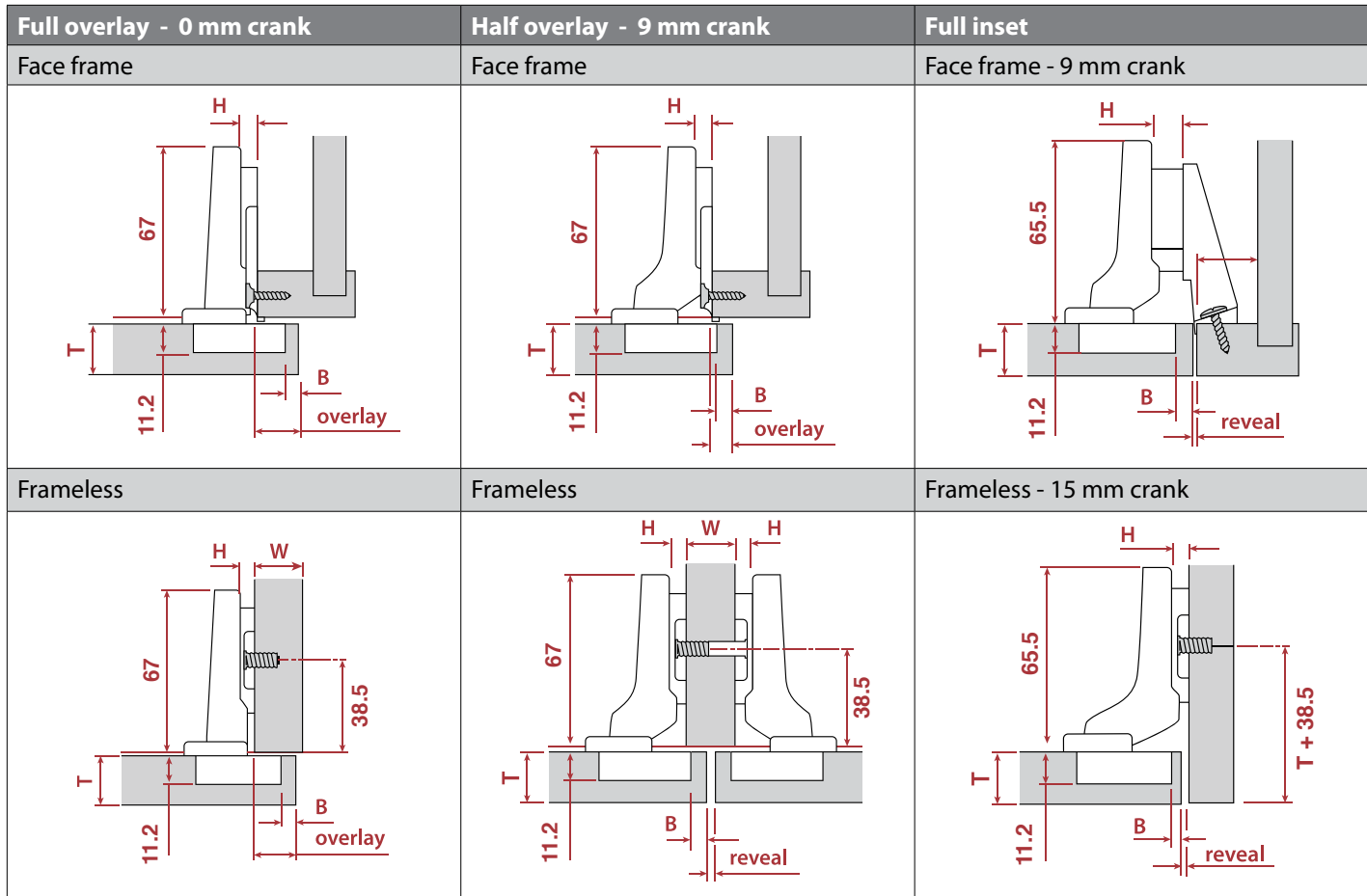

H	Overlay - 90°					P	S
0	14	15	16	17	18	4	19
2	12	13	14	15	16	6	21
3	11	12	13	14	15	7	22
6	8	9	10	11	12	10	25
9	5	6	7	8	9	13	28
	3	4	5	6	7	Fixed distance = 11	
	B = boring distance						

H	Overlay - 110°					P	S
0	15	16	17	18	19	5	18
2	13	14	15	16	17	7	20
3	12	13	14	15	16	8	21
6	9	10	11	12	13	11	24
9	6	7	8	9	10	14	27
	3	4	5	6	7	Fixed distance = 12	
	B = boring distance						

H	Overlay					P	S
0	5.5	6.5	7.5	8.5	9.5	14.5	27
	3	4	5	6	7	Fixed distance = 2.5	
	B = boring distance						

H	Reveal					W	P	S
0	5	3	1	-1	-3	16	14.5	27
	8	6	4	2	0	19		
	11	9	7	5	3	22		
	3	4	5	6	7			
	B = boring distance							

Hinge Length	67 (65.5 inset)
Mounting Dimension for Frameless Application*	38.5
Cup bore depth	11.2

* Inset is "T+" (T=door thickness)

H	Reveal					P	S
2	2.5	1.5	0.5	-	-	25	36.5
9	0	-	-	-	-	22	33.5
	3	4	5	6	7	Fixed distance = -5.5	
	B = boring distance						

Abbreviations	
H	= Plate height
P	= Door protrusion
S	= Side arm protrusion
T	= Door thickness
W	= Side panel width

Subject to technical modifications without notice.
Dimensions in millimeters (inch equivalents as noted)

Standard Duty European Hinges

500 Series

European Hinges

110° Hinges

Free-swinging

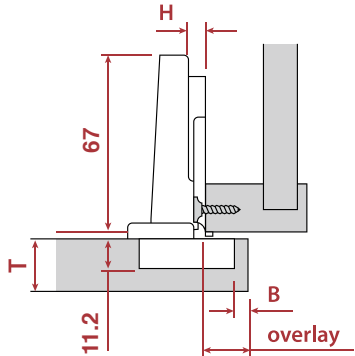
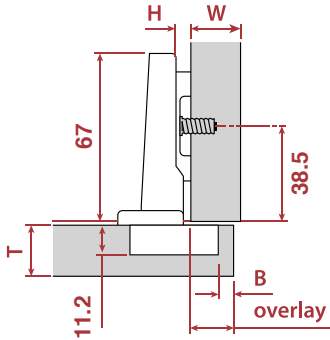
Full overlay - 0 mm crank	
Face frame	
	
Frameless	
	

H	Overlay					P	S
0	14	15	16	17	18	5.5	20
2	12	13	14	15	16	7.5	22
3	11	12	13	14	15	8.5	23
6	8	9	10	11	12	11.5	26
9	5	6	7	8	9	14.5	29
	3	4	5	6	7	Fixed distance = 11	
	B = boring distance						

Hinge Length	67
Mounting Dimension for Frameless Application*	38.5
Cup bore depth	11.2

* Inset is "T+" (T=door thickness)

Subject to technical modifications without notice.
Dimensions in millimeters (inch equivalents as noted)

125° Hinges

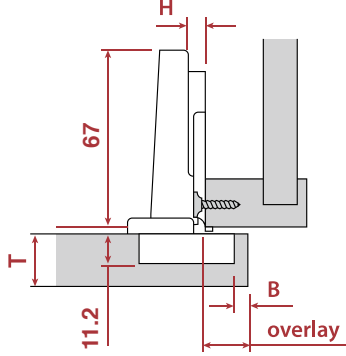
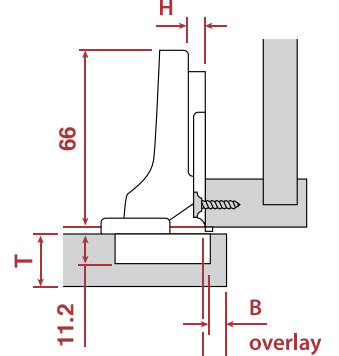
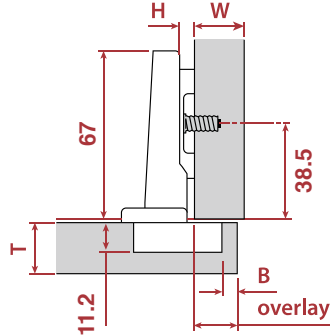
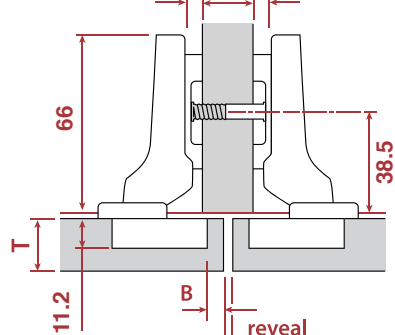
Full overlay - 0 mm crank		Half overlay - 9 mm crank	
Face frame		Face frame	
			
Frameless		Frameless	
			

H	Overlay					P	S
0	15	16	17	18	19	7.5	20
2	13	14	15	16	17	9.5	22
3	12	13	14	15	16	10.5	23
6	9	10	11	12	13	13.5	26
9	6	7	8	9	10	16.5	29
	3	4	5	6	7	Fixed distance = 12	
	B = boring distance						

H	Overlay					P	S
0	5	6	7	8	9	20.5	30
	3	4	5	6	7	Fixed distance = 2	
	B = boring distance						

H	Reveal					W	P	S
0	6	4	2	~	~	16	20.5	30
	9	7	5	3	1	19		
	12	10	8	6	4	22		
	3	4	5	6	7			
	B = boring distance							

Hinge Length	67 (66 partial)
Mounting Dimension for Frameless Application*	38.5
Cup bore depth	11.2

* Inset is "T+" (T=door thickness)

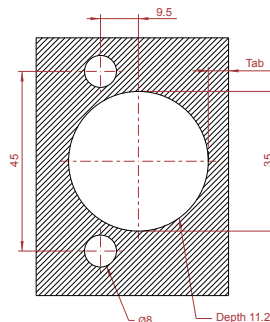

Standard Duty European Hinges 500 Series

170° Hinges

Full overlay - 0 mm crank

Face frame

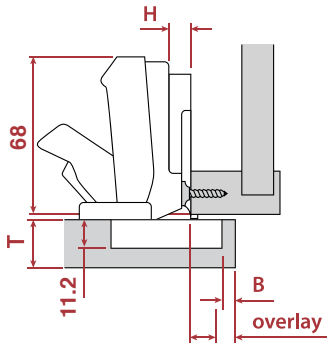

Frameless

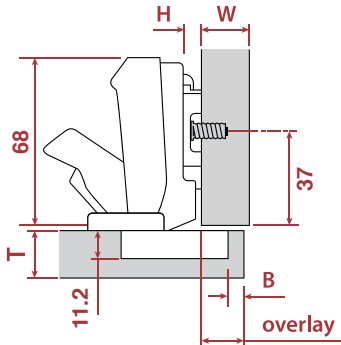

H	Overlay					P	S
0	14	15	16	17	18	-8	53
2	12	13	14	15	16	-6	55
3	11	12	13	14	15	-5	56
6	8	9	10	11	12	-2	59
9	5	6	7	8	9	1	62
	3	4	5	6	7	Fixed distance = 11	
	B = boring distance						

Abbreviations	
H	= Plate height
P	= Door protrusion
S	= Side arm protrusion
T	= Door thickness
W	= Side panel width

Thick door application

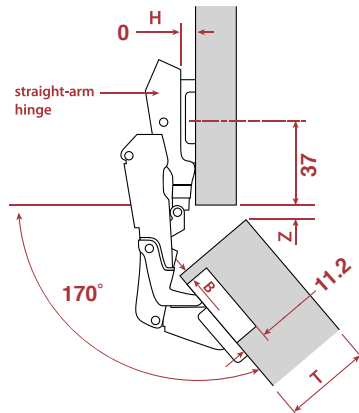

Z=Gap				
23	20	17	14	11
25	29	32	35	38
T = door thickness				

Twin door application

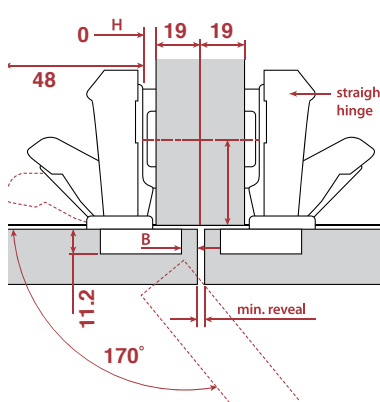

Minimum reveal table					S
0	0	0	14	17	48
19	22	25	29	32	
T = door thickness					

Hinge Length	68
Mounting Dimension for Frameless Application*	37
Cup bore depth	11.2

* Inset is "T+" (T=door thickness)

Subject to technical modifications without notice.
Dimensions in millimeters (inch equivalents as noted)

Hinge Web Ordering Tools













Smart Filtering Search by Criteria

- Type of hinge
- Soft-close or self-close
- Face frame or frameless
- Degree of opening
- Overlay type
- With dowels or without
- Mounting plates

The screenshot displays the Hardware Resources website's smart filtering tool. The top navigation bar includes 'My Ideas Log In | Catalogs | About | FAQ |'. Below the navigation, there are filters for 'By Product Type', 'By Brand', 'Tools For Pros', and 'For Consumers'. The main content area shows a grid of hinge products with details such as '110 Degree Soft Close Basic Clip On Cam ...' and '125 Degree Soft Close Basic Clip On Cam ...'. A 'Smart Filtering' sidebar on the right shows the selected criteria: European Hinge, Soft-Close, Face Frame, and 110° Degree. A 'Go back | Start over' button is located at the bottom of the filter panel.







Mounting Plates for 500 Series Hinges

Frameless Cabinetry	0 mm	3 mm	9 mm	18 mm
Heavy Duty Zinc Die Cast Cam Adjustable Plates				
	3-hole mounting for added stability and secure attachment Material: Zinc die cast, nickel plated Preassembled with 6.3 mm x 15 mm Euro system screws Height adjustment: +/- 3 mm		400.OP30.05 200/ctn	400.OP32.05 200/ctn
	3-hole mounting for added stability and secure attachment Material: Zinc die cast, nickel plated Use #6 x 5/8" flat head wood screws for attachment Height adjustment: +/- 3 mm		400.OR30.05 200/ctn	400.OR32.05 200/ctn
	Material: Zinc die cast, nickel plated Preassembled with 6.3 mm x 15 mm Euro system screws Cam height adjustment: +/- 2 mm		400.OP72.05 200/ctn	400.OP74.05 200/ctn
	Material: Zinc die cast, nickel plated Sold without screws Use #6 x 5/8" flat head wood screws for attachment Cam height adjustment: +/- 2 mm		400.OR23.05 200/ctn	400.OR25.05 200/ctn
Heavy Duty Zinc Die Cast Non-Cam Adjustable Plates				
	Material: Zinc die cast, nickel plated Preassembled with 6.3 mm x 15 mm Euro system screws Height adjustment: +/- 3 mm			400.OP29.05 200/ctn
	Material: Zinc die cast, nickel plated Sold without screws Use #6 x 5/8" flat head wood screws for attachment Height adjustment: +/- 3 mm			400.OP18.05 200/ctn
Standard Duty Steel Cam Adjustable Plates				
	Material: Cold rolled steel, nickel plated Preassembled with 6.3 mm x 15 mm Euro system screws Cam height adjustment: +/- 2 mm		400.OP71.05 200/ctn	400.OP73.05 200/ctn
	Material: Cold rolled steel, nickel plated Sold without screws Use #6 x 5/8" flat head wood screws for attachment Cam height adjustment: +/- 2 mm		400.OR22.05 200/ctn	400.OR24.05 200/ctn
Standard Duty Steel Non-Cam Adjustable Plates				
	Material: Cold rolled steel, nickel plated Preassembled with 6.3 mm x 15 mm Euro system screws Height adjustment: +/- 3 mm		400.O118.05 200/ctn	400.O119.05 200/ctn
	Material: Cold rolled steel, nickel plated Sold without screws Use #6 x 5/8" flat head wood screws for attachment Height adjustment: +/- 3 mm		400.1233.05 200/ctn	400.1234.05 200/ctn
	Dowels provide a stronger holding force for the hinge and plate Material: Cold rolled steel, nickel plated Preassembled with wood screws and 5 mm expansion dowels Height adjustment: +/- 3 mm		400.2118.05 200/ctn	400.2119.05 200/ctn
	Used for back-to-back hinge installation in 19 mm material Material: Cold rolled steel, nickel plated Preassembled with 6.3 mm x 10 mm shortened Euro system screws Height adjustment: +/- 3 mm		400.3118.05 200/ctn	400.3119.05 200/ctn

Mounting Plates for 500 Series Hinges

European
Hinges

Face Frame Cabinetry		0 mm	3 mm	6 mm	9 mm
Heavy Duty Zinc Die Cast Cam Adjustable Plates					
	Material: Zinc die cast, nickel plated Sold without screws Use #6 x 5/8" flat head wood screws for attachment Cam height adjustment: +/- 3.5 mm Recommended for 125° hinges	400.3723.65 200/ctn	400.3724.65 200/ctn		
	Material: Zinc die cast, nickel plated Sold without screws Use #8 x 3/4" pan head wood screws for attachment Designed for inset applications using 9 mm crank hinges Cam height adjustment: +/- 3.5 mm				400.3458.65 200/ctn
Heavy Duty Zinc Die Cast Non-Cam Adjustable Plates					
	Material: Zinc die cast, nickel plated Sold without screws Use #6 x 5/8" flat head wood screws for attachment Height adjustment: +/- 3.5 mm	400.3453.65 200/ctn	400.3454.65 200/ctn	400.3455.65 200/ctn	
	Material: Zinc die cast, nickel plated Sold without screws Use #6 x 5/8" flat head wood screws for attachment Height adjustment: +/- 3.5 mm Recommended for 125° hinges	400.3713.65 200/ctn	400.3714.65 200/ctn	400.3715.65 200/ctn	
	Material: Zinc die cast, nickel plated Sold without screws Use #6 x 5/8" flat head wood screws for attachment Wrap around designed for MDF/plywood face frames where 4 screws are needed to secure the plate and prevent screw pull out Height adjustment: +/- 3.5 mm			400.3456.65 200/ctn	
Heavy Duty Zinc Die Cast Non-Cam Adjustable Plates for Cabinet Refacing					
	Mounting holes on plate are indexed 1/4" away from face frame. This prevents mounting screws from penetrating the seam between the 1/4" reface material and the face frame. Material: Zinc die cast, nickel plated Sold without screws Use #6 x 5/8" flat head wood screws for attachment Height adjustment: +/- 3.5 mm	400.3553.65 200/ctn	400.3554.65 200/ctn		
Standard Duty Steel Non-Cam Adjustable Plates					
	Material: Stamped steel, nickel plated Sold without screws Use #6 x 5/8" flat head wood screws for attachment Height adjustment: +/- 3.5 mm		400.3457.65 200/ctn		
	Material: Stamped steel, nickel plated Sold without screws Use #6 x 5/8" flat head wood screws for attachment Height adjustment: +/- 3.5 mm Recommended for 125° hinges		400.3717.65 200/ctn		

Hinge & Plate Selection Guide for 500 Series Hinges

<i>Frameless Cabinetry</i>										
<i>Full Overlay</i>					<i>Half Overlay</i>					
<i>Hinge /0 Crank</i>	<i>Dowel</i>	<i>Adj</i>	<i>Plate /0 mm</i>	<i>Mat.</i>	<i>Hinge /9 Crank</i>	<i>Dowel</i>	<i>Adj</i>	<i>Plate /0 mm</i>	<i>Mat.</i>	
90° 500.0161.05	Press-in	Cam	400.1233.05	Steel	110° 500.0536.05	None	Cam	400.1233.05	Steel	
110° 500.0534.05	None	Screw	400.0118.05 Euro	Steel	110° 500.0279.05	Press-in	Screw	400.0118.05 Euro	Steel	
110° 500.0535.05	None	Cam	400.0R22.05 Cam	Steel	110° 500.0179.05	Press-in	Cam	400.0R22.05 Cam	Steel	
110° 500.0171.05	Press-in	Screw	400.0R23.05 Cam	Zinc	125° 500.0U99.05	Lever	Cam	400.0R23.05 Cam	Zinc	
110° 500.0181.05	Press-in	Cam	400.0P72.05 Cam/Euro	Zinc				400.0P72.05 Cam/Euro	Zinc	
110° 500.0186.05	Eazy-Fix	Cam	400.0P71.05 Cam/Euro	Steel				400.0P71.05 Cam/Euro	Steel	
110° 500.0141.05*	Press-in	Cam	400.0P30.05 3-Hole	Zinc				400.0P30.05 3-Hole	Zinc	
125° 500.0U85.05	None	Cam	400.0R30.05 3-Hole	Zinc				400.0R30.05 3-Hole	Zinc	
125° 500.0U84.05	Press-in	Cam	400.2118.05 Dowels	Steel				400.2118.05 Dowels	Steel	
125° 500.0U86.05	Eazy-Fix	Cam	400.3118.05 Short Screw	Steel				400.3118.05 Short Screw	Steel	
125° 500.0U94.05	Lever	Cam								
170° 500.0M73.05	Press-in	Screw								
<i>*500.0141.05 is free-swinging non-self-closing</i>										
<i>Inset</i>					<i>45 Degree</i>					
<i>Hinge /15 Crank</i>	<i>Dowel</i>	<i>Adj</i>	<i>Plate /3 mm</i>	<i>Mat.</i>	<i>Hinge /18 Crank</i>	<i>Dowel</i>	<i>Adj</i>	<i>Plate/0 mm</i>	<i>Mat.</i>	
110° 500.0537.05	None	Screw	400.1234.05	Steel	105° 500.0N20.05	Press-in	Screw	400.1233.05	Steel	
110° 500.0280.05	Press-in	Screw	400.0119.05 Euro	Steel				400.0118.05 Euro	Steel	
			400.0R24.05 Cam	Steel				400.0R22.05 Cam	Steel	
			400.0R25.05 Cam	Zinc				400.0R23.05 Cam	Zinc	
			400.0P73.05 Cam/Euro	Steel				400.0P72.05 Cam/Euro	Zinc	
			400.0P74.05 Cam/Euro	Zinc				400.0P71.05 Cam/Euro	Steel	
			400.0P32.05 3-Hole	Zinc				400.0P30.05 3-Hole	Zinc	
			400.0R32.05 3-Hole	Zinc				400.0R30.05 3-Hole	Zinc	
			400.2119.05 Dowels	Steel				400.2118.05 Dowels	Steel	
			400.3119.05 Short Screw	Steel				400.3118.05 Short Screw	Steel	
<i>90 Degree Blind Corner (Inset application/no overlay)</i>										
<i>Hinge /18 Crank</i>	<i>Dowel</i>	<i>Adj</i>	<i>Plate/0 mm</i>	<i>Mat.</i>						
105° 500.0N24.05	Press-in	Screw	400.1233.05	Steel						
			400.0118.05 Euro	Steel						
			400.0R22.05 Cam	Steel						
			400.0R23.05 Cam	Zinc						
			400.0P72.05 Cam/Euro	Zinc						
			400.0P71.05 Cam/Euro	Steel						
			400.0P30.05 3-Hole	Zinc						
			400.0R30.05 3-Hole	Zinc						

Hinge & Plate Selection Guide for 500 Series and Compact Hinges

European
Hinges

Face Frame Cabinetry									
3/4" Overlay					1/2" Overlay				
Hinge /0 Crank	Dowel	Adj	Plate /0 mm	Mat.	Hinge /0 Crank	Dowel	Adj	Plate /3 mm	Mat.
90° 500.0161.05	Press-in	Cam	400.3453.65 110	Zinc	90° 500.0161.05	Press-in	Cam	400.3454.65 110	Zinc
110° 500.0534.05	None	Screw	400.3713.65 125	Zinc	110° 500.0534.05	None	Screw	400.3717.65 125	Steel
110° 500.0535.05	None	Cam	400.3723.65 125/Cam	Zinc	110° 500.0535.05	None	Cam	400.3457.65 110	Steel
110° 500.0171.05	Press-in	Screw			110° 500.0171.05	Press-in	Screw	400.3456.65 Wrap Around	Zinc
110° 500.0181.05	Press-in	Cam			110° 500.0181.05	Press-in	Cam	400.3714.65 125	Zinc
110° 500.0186.05	Eazy-Fix	Cam			110° 500.0186.05	Eazy-Fix	Cam	400.3724.65 125/Cam	Zinc
110° 500.0141.05*	Press-in	Cam			110° 500.0141.05*	Press-in	Cam		
125° 500.0U85.05	None	Cam			125° 500.0U85.05	None	Cam		
125° 500.0U84.05	Press-in	Cam			125° 500.0U84.05	Press-in	Cam		
125° 500.0U86.05	Eazy-Fix	Cam			125° 500.0U86.05	Eazy-Fix	Cam		
125° 500.0U94.05	Lever	Cam			125° 500.0U94.05	Lever	Cam		
170° 500.0M73.05	Press-in	Screw			170° 500.0M73.05	Press-in	Screw		
*500.0141.05 is free-swinging non-self-closing					*500.0141.05 is free-swinging non-self-closing				
3/8" Overlay					Inset				
Hinge /9 Crank	Dowel	Adj	Plate /0 mm	Mat.	Hinge /9 Crank	Dowel	Adj	Plate /9 mm Inset	Mat.
110° 500.0536.05	None	Cam	400.3453.65 110	Zinc	110° 500.0536.05	None	Cam	400.3458.65 Cam	Zinc
110° 500.0U99.05	Lever	Cam	400.3713.65 125	Zinc	110° 500.0U99.05	Lever	Cam		
110° 500.0279.05	Press-in	Screw	400.3723.65 125/Cam	Zinc	110° 500.0279.05	Press-in	Screw		
110° 500.0179.05	Press-in	Cam			110° 500.0179.05	Press-in	Cam		
125° 500.0U99.05	Lever	Cam							
1/4" Overlay					Pie Corner				
Hinge /9 Crank	Dowel	Adj	Plate/3 mm	Mat.	Hinge /18 Crank	Dowel	Adj	Plate /0 mm	Mat.
110° 500.0536.05	None	Cam	400.3454.65 110	Zinc	105° 500.0U22.05	Press-in	Screw	400.1233.05	Steel
110° 500.0U99.05	Lever	Cam	400.3717.65 125	Steel				400.0R22.05 Cam	Steel
110° 500.0279.05	Press-in	Screw	400.3456.65 Wrap Around	Zinc				400.0R23.05 Cam	Zinc
110° 500.0179.05	Press-in	Cam	400.3714.65 125	Zinc					
			400.3724.65 125/Cam	Zinc					
			400.3457.65	Steel					

Face Frame Cabinetry - Compact Hinges									
3/4" Overlay					1/2" Overlay				
Hinge	Dowel	Adj	Plate		Hinge	Dowel	Adj	Plate	
105° 3390-6-000	Press-in	Cam	No plate needed		105° 3390	Press-in	Cam	No plate needed	
125° 22855-6-000N	Press-in	Cam	Plate included		105° 3390-2-000	Press-in	Cam	No plate needed	
					105° 3390-3-000	Eazy-Fix	Cam	No plate needed	
					125° 22855-7-000N	Press-in	Cam	Plate included	
					125° 22855-8-000N	None	Cam	Plate included	
					125° 22855-9	Press-in	Cam	Cam adj. plate included	
					125° 22855-10	None	Cam	Cam adj. plate included	
Pie Corner					1/2" Overlay Soft-close				
Hinge	Dowel	Adj	Plate		Hinge	Dowel	Adj	Plate	
160° 22877-000	None	Screw	No plate needed. Tab -4 mm		105° 22855-9SFT	Press-in	Cam	Cam adj. plate included	
					105° 22855-10SFT	None	Cam	Cam adj. plate included	

45° Corner Overlay 700 Series Soft-close Hinge

Soft-close heavy duty hinge designed for 45 degree inside corner and overlay applications.



Inside Corner
18 mm Crank

APPLICATION



Press-in
8 mm Dowels

Soft-close
700.0N20.05
100/ctn

Specs

- 105° opening angle
- 1- stop action
- Hinge and plate provide 6-way adjustability
- Cold rolled steel with nickel plating
- 45 mm boring pattern
- Recommended for use with 600 Series 0 mm plates

Inside corner - 18 mm crank

Frameless

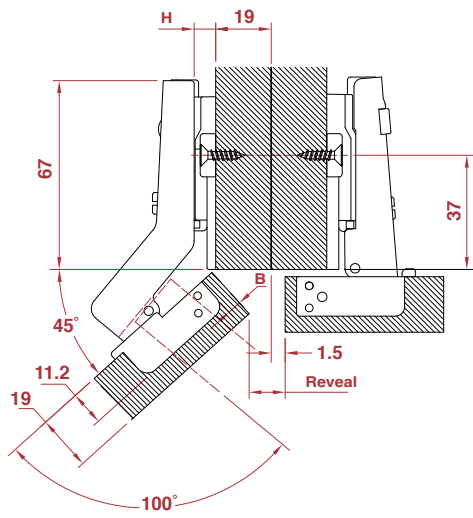

H	Overlay					P	S
0	3	4	5	6	7	10.5	30
	3	4	5	6	7	Fixed distance = 0	
	B = boring distance						

H	Inside Corner				P	S	
0	4	3	2	1	10.5	30	
	3	4	5	6			
	B = boring distance						
NOTE: Reveal based on 19(3/4") side panel							

H	Y = Gap			
0	3.5	2.5	1.5	0.5
	3	4	5	6
	B = boring distance			
NOTE: Reveal based on 19(3/4") side panel				

Hinge Length	67
Mounting Dimension for Frameless Application*	37
Cup bore depth	11.2

* Inset is "T+" (T=door thickness)

Abbreviations	
H	= Plate height
P	= Door protrusion
S	= Side arm protrusion

Subject to technical modifications without notice.
Dimensions in millimeters (inch equivalents as noted)

Application



Opening Angle



Finish



Adjustment



Overlay



Boring Hole Pattern



Material



Packaging

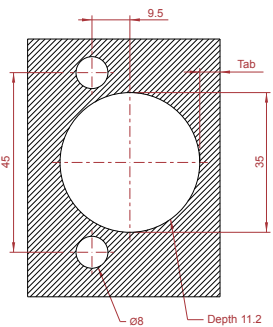

45° Corner Overlay 500 Series Hinge

Specialty
Hinges

Self-close standard duty hinge designed for 45 degree inside corner and overlay applications.

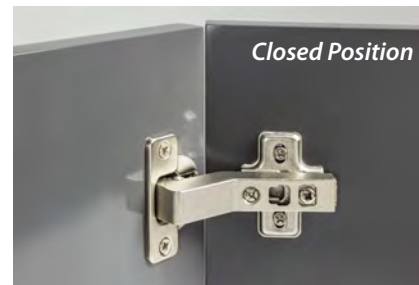

Inside Corner
18 mm Crank

APPLICATION



Press-in
8 mm Dowels

500.0N20.05
100/ctn

Specs

105° opening angle

1- stop action

Hinge and plate provide 6-way adjustability

Cold rolled steel with nickel plating

45 mm boring pattern

Recommended for use with 400 Series 0 mm plates

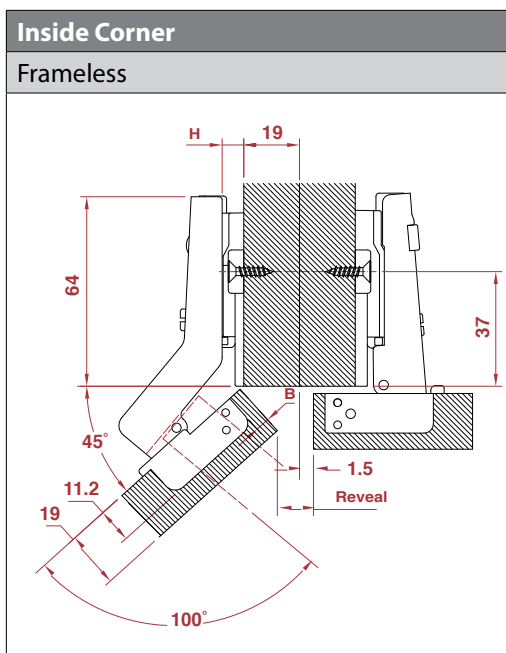

H	Overlay						P	S
0	-2	-1	0	1	2	14	38	
	3	4	5	6	7	Fixed distance = -5		
B = boring distance								

H	Inside Corner				P	S
0	8.5	7.5	6.5	5.5	14	38
	3	4	5	6		
B = boring distance						
NOTE: Reveal based on 19(3/4") side panel						

H	Y = Gap			
0	8	7	6	5
	3	4	5	6
B = boring distance				
NOTE: Reveal based on 19(3/4") side panel				

Hinge Length	64
Mounting Dimension for Frameless Application*	37
Cup bore depth	11.2

* Inset is "T+" (T=door thickness)

Abbreviations	
H	= Plate height
P	= Door protrusion
S	= Side arm protrusion

Application

Face frame
Frameless

Opening Angle

105°

Finish

Nickel Plating

Adjustment

6 way

Overlay

Corner Overlay

Boring Hole Pattern

45 mm

Material

Steel

Packaging

100/
carton

Subject to technical modifications without notice.
Dimensions in millimeters (inch equivalents as noted)

hardware
resources

800.463.0660 | www.HardwareResources.com

[737]

90° Blind Corner Inset 700 Series Built-in Soft-close Hinge

Soft-close heavy duty hinge designed for 90 degree blind corner inset applications.



APPLICATION

*Blind Corner
0 mm Crank*



*Press-in
8 mm Dowels*

*Soft-close
700.0N24.05
200/ctn*

Specs

- 105° opening angle
- 1- stop action
- Hinge and plate provide 6-way adjustability
- Cold rolled steel with nickel plating
- 45 mm boring pattern
- Recommended for use with 600 Series 0 mm plates

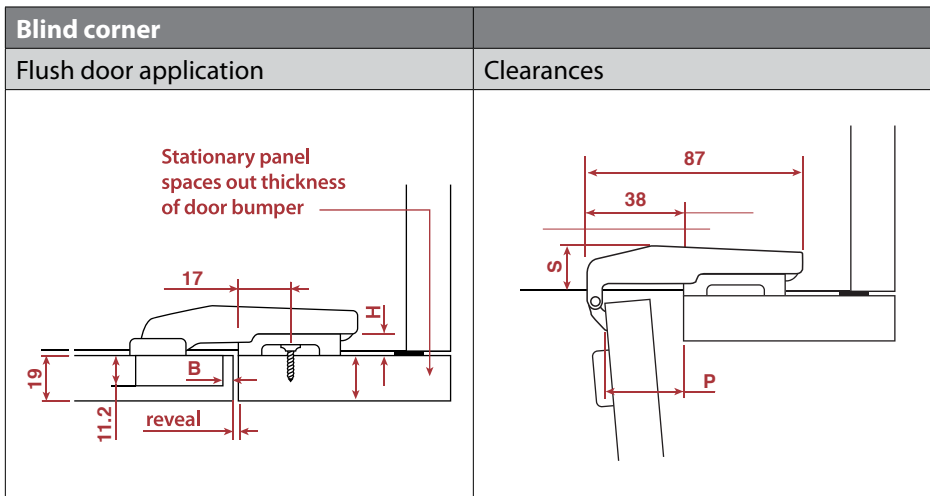

H	Reveal					P	S
0	4	3	2	1	0	24.5	22.0
	3	4	5	6	7	FD	
	B=boring distance						-7

Hinge Length	88.0
Cup bore depth	11.2

* Inset is "T+" (T=door thickness)

Abbreviations	
H	= Plate height
P	= Door protrusion
S	= Side arm protrusion
T	= Door thickness
W	= Side panel width

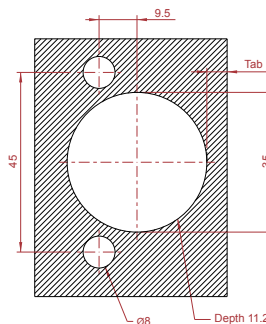

Application

- Face frame
- Frameless

Opening Angle



Finish



Adjustment



Inset



Boring Hole Pattern



Material



Packaging



90° Blind Corner Inset 500 Series Hinge

Specialty
Hinges

Self-close standard duty hinge designed for 90 degree blind corner inset applications.

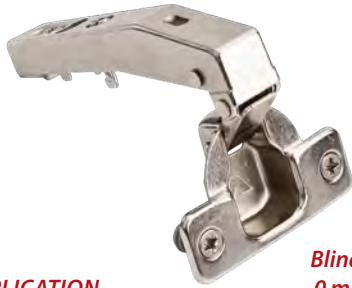

APPLICATION

Blind Corner
0 mm Crank



Press-in
8 mm Dowels

500.0N24.05
200/ctn



Open Position



Closed Position

Specs

105° opening angle

1- stop action

Hinge and plate provide 6-way adjustability

Cold rolled steel with nickel plating

45 mm boring pattern

Recommended for use with 400 Series 0 mm plates

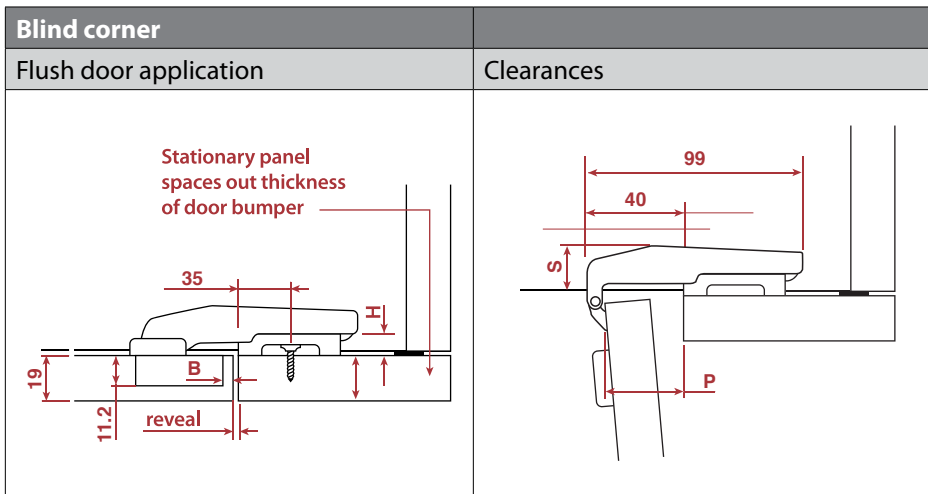

H	Reveal					P	S
0	6	5	4	3	2	28.0	21.0
	3	4	5	6	7	FD	
	B=boring distance						-9

Hinge Length	102.0
Cup bore depth	11.2

* Inset is "T+" (T=door thickness)

Abbreviations	
H	= Plate height
P	= Door protrusion
S	= Side arm protrusion
T	= Door thickness
W	= Side panel width

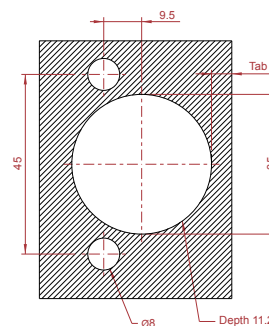

Application

Face frame
Frameless

Opening Angle

105°

Finish

Nickel
Plating

Adjustment

6 way

Inset

Blind
Corner

Boring Hole Pattern

45 mm

Material

Steel

Packaging

200/
carton

105° Pie Corner Hinge 500 Series



Pie Corner
18 mm Crank

Self-close standard duty hinge designed for connecting two doors in a corner cabinet with no need for a magnetic catch.

APPLICATION



Press-in
8 mm Dowels

500.0U22.05
100/ctn

Specs

105° opening angle
1- stop action
Hinge and plate provide 6-way adjustability

Cold rolled steel with nickel plating
45 mm boring pattern
Recommended for use with 400 Series 0 mm plates

Inside corner application

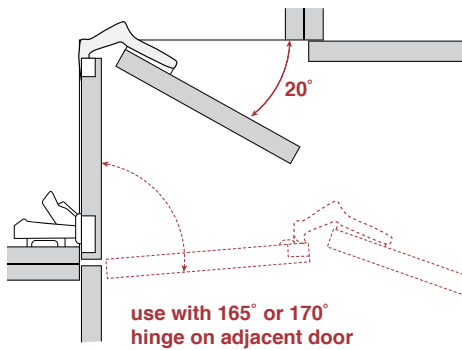

Abbreviations	
DW	= Door width
G	= Gap
H	= Plate height
IW	= Interior width
R	= Reveal
T	= Door thickness
W	= Side panel width



With flat panel doors

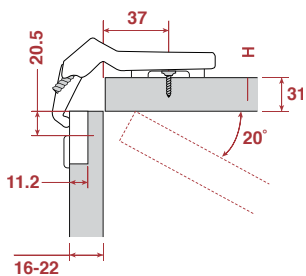

General specifications

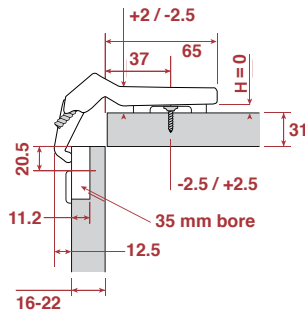

Adjustment

The cam adjustment of the pie corner European hinge allows for -2/ +2.5 mm adjustment

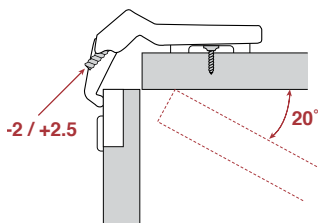

Boring Pattern

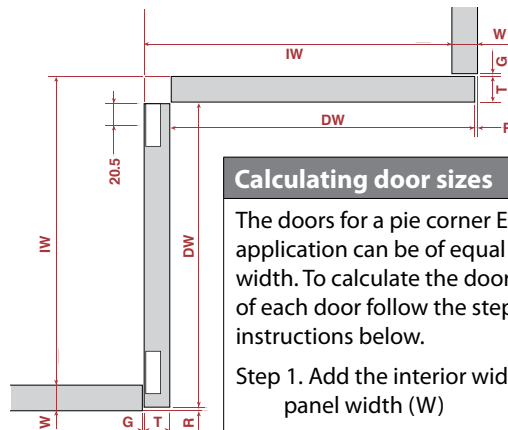
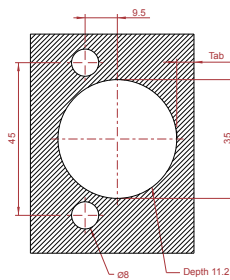

Calculating door sizes

The doors for a pie corner European hinge application can be of equal or unequal width. To calculate the door width (DW) of each door follow the step-by-step instructions below.

- Step 1. Add the interior width to the side panel width (W)
- Step 2. Subtract door thickness (T) and reveal (R)
- Step 3. Subtract gap (G) and bumper thickness behind adjacent door

Formula: $DW = (IW + W) \text{ minus } T \text{ minus } R \text{ minus } G$

Example: $DW = (500 + 19) - 19 - 3 - 1$
 $DW = 496 \text{ mm}$

130° Pie-cut Corner Hinge 22877 Series

Specialty
Hinges

Specialty hinge designed for a pie-cut corner application with a shallow profile that does not interfere with lazy susans.

Specs

160° opening angle
Height adjustment
Zinc die cast construction with nickel plating



APPLICATION

Pie Corner



22877-000
200/ctn

No Dowels

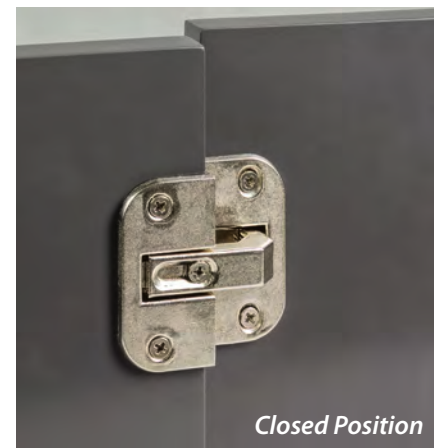
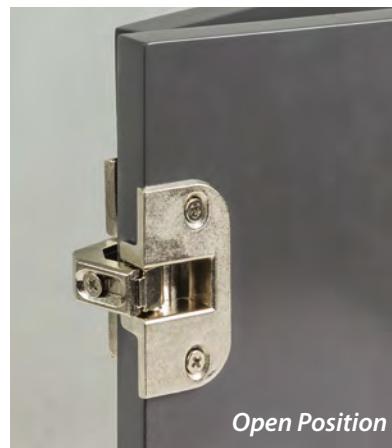
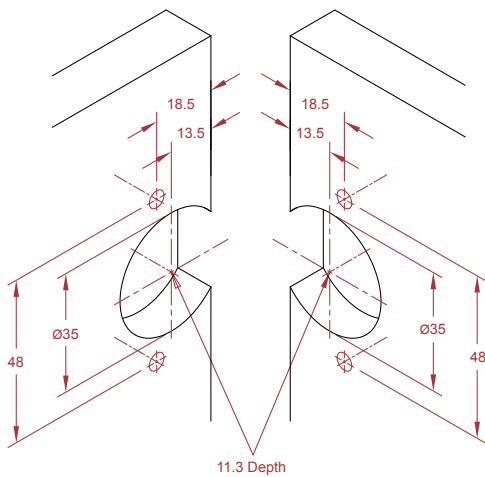

Compact Hinges

Our complete family of compact hinges offer more options when it comes to face frame applications: 4-way & 6-way adjustability, soft-close & self-close, and a refacing option. You have a choice with our Dura-Close[®], Soft-close and Standard Duty hinge series.

800.463.0660
www.HardwareResources.com

hardware
resources[®]

NEW

**Dura-Close® Compact Soft-close Hinges:
7390 Series**



[746]

NEW

**Dura-Close® Compact Hinges:
6390 Series**



[748]

**Standard Duty
Compact Soft-close Hinges:
5390 Series**



[750]

**Standard Duty
Compact Hinges:
4390 Series**



[752]

**Economical
Compact Hinges:
3390 Series**



[754]

**Dual Pivot
Compact Soft-close Hinges:
22855 Series**



[756]

**Dual Pivot
Compact Hinges:
22855 Series**



[757]

HR Series Comparison Compact Hinges

Compact
Hinges



4390	3390	22855.SFT	22855
Standard Self-close	Economical Self-close	Dual Pivot Point Soft-close	Dual Pivot Point Self-close
50,000+	50,000+	50,000+	50,000+
✓			
			✓
		✓ concealed	
✓	✓	✓	✓
Single	Single	Dual	Dual
105	105	105	125
7/16" - 1-1/2"	7/16" - 1-1/2"	1/2" Only	1/2" Only

Dura-Close® Compact Soft-close Hinges 7390 Series

Hardware Resources' smoothest and most long-lasting soft-close hinge to date is perfect for when quality and performance are a must.

Features

- Patent pending spring sleeves reduce friction and wear
- Grade 2 ANSI/BHMA certified to 2X ANSI 100,000 cycles
- 2-cleat options available for face frame material over 3/4"
- One piece compact assembly with vertical screw adjustment and horizontal and depth cam adjustment



NEW

Specs

- 105 degree opening angle
- Single pivot point
- 6-way adjustability
- Cold rolled steel with nickel plating
- 45 mm boring pattern
- Compatible with 6390 Series self-close hinges
- #7 x 5/8" pan washer head screw (7X0580WCQ) recommended



APPLICATION

3/8" Overlay

7/16" Overlay

1/2" Overlay

3/4" Overlay

1" Overlay

1-1/4" Overlay

1-3/8" Overlay

1-1/2" Overlay



	3/8" Overlay	7/16" Overlay	1/2" Overlay	3/4" Overlay	1" Overlay	1-1/4" Overlay	1-3/8" Overlay	1-1/2" Overlay
No Dowels			7390 200/ctn					
			7390-2C*					
			200/ctn					
Press-in 8 mm Dowels	7390-038 200/ctn	7390-716 200/ctn	7390-2-000 200/ctn	7390-6-000 200/ctn	7391-000 200/ctn	7394-000 200/ctn	7393-000 200/ctn	7392-000 200/ctn
			7390-2-2C*			7394-2C*		
			200/ctn			200/ctn		

*2C = 2-Cleat Hinge

Application

Face frame

Opening Angle

105°

Finish

Nickel Plating

Adjustment

6 way

Overlay

3/8" - 1 1/2"

Boring Hole Pattern

45 mm

Material

Steel

Packaging

200/ carton

Certification

2X ANSI 100,000+

Dura-Close® Compact Soft-close Hinges 7390 Series

Compact Hinges

Three-dimensional door adjustment

Horizontal adjustment

Rotate front screw to increase or decrease door overlay.

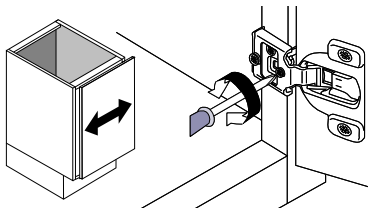

Vertical adjustment

Rotate center cam screw to adjust door position.

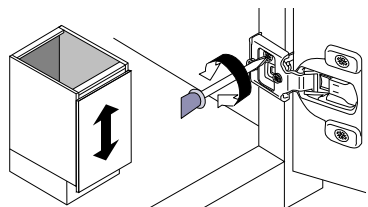

Depth adjustment

Rotate rear cam screw to adjust door position.

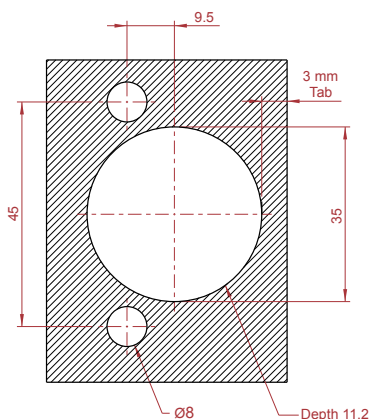
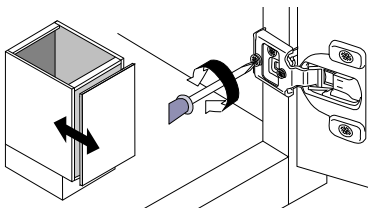

Subject to technical modifications without notice.
Dimensions in millimeters (inch equivalents as noted)

	Boring Depth	Tab
7390 Series	11.2 mm	3 mm

105° Hinges

3/8" to 1" Overlay

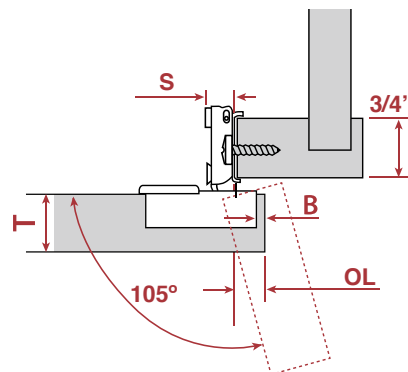

H	Overlay	P	S
7390-038	9.5 mm (3/8")	8 mm (5/16")	13 mm (1/2")
7390-716	11 mm (7/16")	8 mm (5/16")	13 mm (1/2")
7390	13 mm (1/2")	6 mm (1/4")	13 mm (1/2")
7390-2-000	13 mm (1/2")	6 mm (1/4")	13 mm (1/2")
7390-6-000	19 mm (3/4")	0	13 mm (1/2")
7391-000	25.4 mm (1")	0	9.5 mm (3/8")
Boring distance = 3 mm		Minimum Reveal = 7 mm (9/32")	

1-1/4" to 1-1/2" Overlay

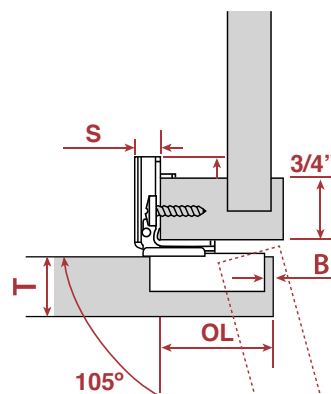

H	Overlay	P	S
7394-000	32 mm (1-1/4")	0	9.5 mm (3/8")
7393-000	35 mm (1-3/8")	0	9.5 mm (3/8")
7392-000	38 mm (1-1/2")	0	9.5 mm (3/8")
Boring distance = 3 mm		Minimum Reveal = 7 mm (9/32")	

Abbreviations

H	= Item number
P	= Door protrusion
S	= Hinge arm protrusion
T	= Door thickness

Dura-Close® Compact Hinges 6390 Series

When performance and end user satisfaction are a must, you can't go wrong with the 6390 Series self-close hinges.

Features

- Patent pending spring sleeves reduce friction and wear
- Grade 2 ANSI/BHMA certified to 2X ANSI 100,000 cycles
- 2-cleat options available for face frame material over 3/4"
- One piece compact assembly with vertical screw adjustment and horizontal and depth cam adjustment



NEW



Specs

- 105 degree opening angle
- Single pivot point
- 6-way adjustability
- Cold rolled steel with nickel plating
- 45 mm boring pattern
- Compatible with 7390 Series soft-close hinges
- #7 x 5/8" pan washer head screw (7X0580WCQ) recommended



APPLICATION

- 3/8" Overlay
- 7/16" Overlay
- 1/2" Overlay
- 3/4" Overlay
- 1" Overlay
- 1-1/4" Overlay
- 1-3/8" Overlay
- 1-1/2" Overlay



No Dowels



Press-in 8 mm Dowels

			6390 200/ctn					
			6390-2C*					
			200/ctn					
	6390-038	6390-716	6390-2-000	6390-6-000	6391-000	6394-000	6393-000	6392-000
	200/ctn	200/ctn	200/ctn	200/ctn	200/ctn	200/ctn	200/ctn	200/ctn
			6390-2-2C*			6394-2C*		
			200/ctn			200/ctn		

*2C = 2-Cleat Hinge

Application Opening Angle Finish Adjustment

Face frame

105°

Nickel Plating

6 way

Overlay Boring Hole Pattern Material Packaging Certification

3/8" – 1 1/2"

45 mm

Steel

200/ carton

2X ANSI 100,000+

Dura-Close® Compact Hinges 6390 Series

Compact Hinges

Three-dimensional door adjustment

Horizontal adjustment

Rotate front screw to increase or decrease door overlay.

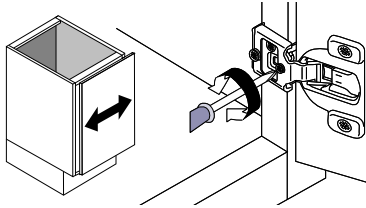

Vertical adjustment

Rotate center cam screw to adjust door position.

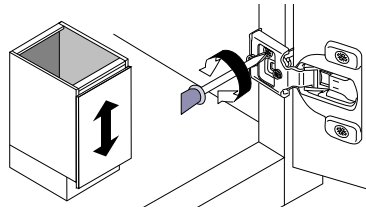

Depth adjustment

Rotate rear cam screw to adjust door position.

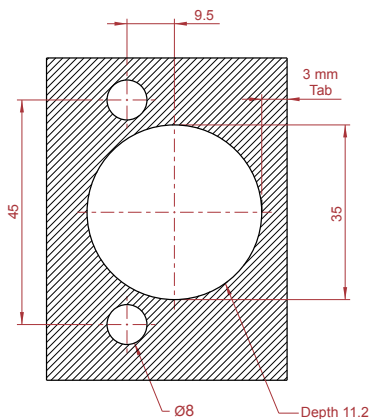
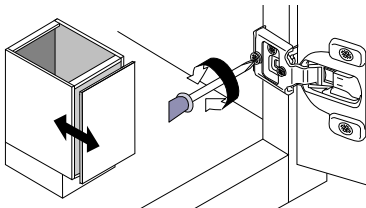

Subject to technical modifications without notice.
Dimensions in millimeters (inch equivalents as noted)

	Boring Depth	Tab
6390 Series	11.2 mm	3 mm

105° Hinges

3/8" to 1" Overlay

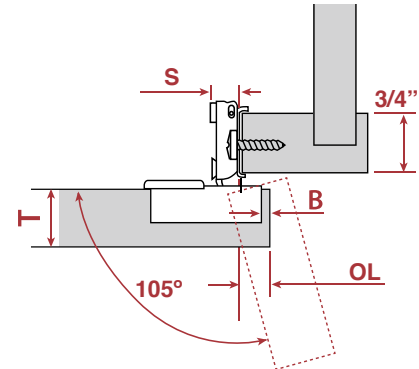

H	Overlay	P	S
6390-038	9.5 mm (3/8")	8 mm (5/16")	13 mm (1/2")
6390-716	11 mm (7/16")	8 mm (5/16")	13 mm (1/2")
6390	13 mm (1/2")	6 mm (1/4")	13 mm (1/2")
6390-2-000	13 mm (1/2")	6 mm (1/4")	13 mm (1/2")
6390-6-000	19 mm (3/4")	0	13 mm (1/2")
6391-000	25.4 mm (1")	0	9.5 mm (3/8")
Boring distance = 3 mm		Minimum Reveal = 7 mm (9/32")	

1-1/4" to 1-1/2" Overlay

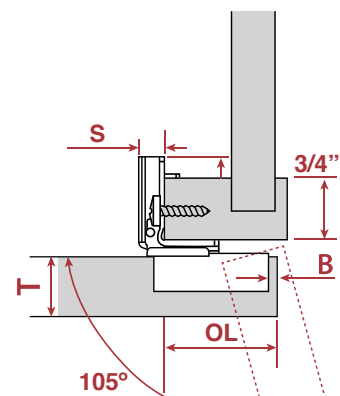

H	Overlay	P	S
6394-000	32 mm (1-1/4")	0	9.5 mm (3/8")
6393-000	35 mm (1-3/8")	0	9.5 mm (3/8")
6392-000	38 mm (1-1/2")	0	9.5 mm (3/8")
Boring distance = 3 mm		Minimum Reveal = 7 mm (9/32")	

Abbreviations

H	= Item number
P	= Door protrusion
S	= Hinge arm protrusion
T	= Door thickness

Compact Soft-close Hinges 5390 Series

Designed for customers who want an upgraded soft-close hinge with a stylish metal damper cover, these hinges fit the bill every time.

Features

- Designed spring and arm for better support
- Grade 2 ANSI/BHMA certified to ANSI 50,000 cycles
- One piece compact assembly with vertical screw adjustment and horizontal and depth cam adjustment

Specs

- 105 degree opening angle
- Single pivot point
- 6-way adjustability
- Cold rolled steel with nickel plating
- 45 mm boring pattern
- Compatible with 4390 Series self-close hinges
- #7 x 5/8" pan washer head screw (7X0580WCQ) recommended



APPLICATION





	7/16" Overlay	1/2" Overlay	3/4" Overlay	1" Overlay	1-1/4" Overlay	1-3/8" Overlay	1-1/2" Overlay
No Dowels	5390 200/ctn						
Press-in 8 mm Dowels	5390-716 200/ctn	5390-2-000 200/ctn	5390-6-000 200/ctn	5391-000 200/ctn	5394-000 200/ctn	5393-000 200/ctn	5392-000 200/ctn



90° Restrictor Clip 5390.RC
100 pcs/box*

*FULL BOX QUANTITIES ONLY

Application	Opening Angle	Finish
Face frame	 105°	 Nickel Plating

Adjustment	Overlay	Boring Hole Pattern	Material	Packaging	Certification
 6 way	7/16" – 1 1/2"	 45 mm	 Steel	 200/ carton	 ANSI BHMA

Compact Soft-close Hinges 5390 Series

Compact
Hinges

Three-dimensional door adjustment

Horizontal adjustment

Rotate front screw to increase or decrease door overlay.

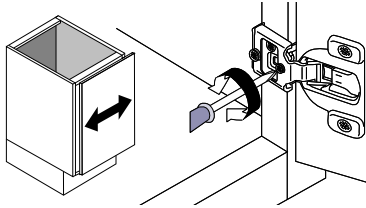

Vertical adjustment

Rotate center cam screw to adjust door position.

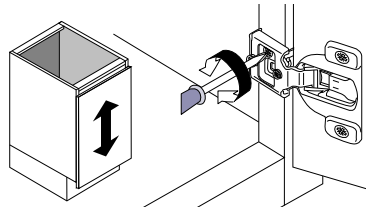

Depth adjustment

Rotate rear cam screw to adjust door position.

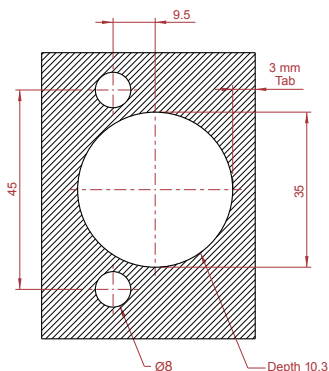
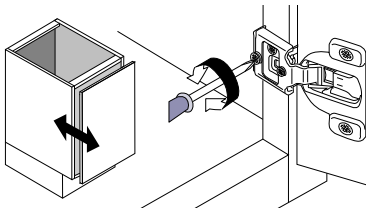

Subject to technical modifications without notice.
Dimensions in millimeters (inch equivalents as noted)

	Boring Depth	Tab
5390 Series	10.3 mm	3 mm

105° Hinges

7/16" to 1" Overlay

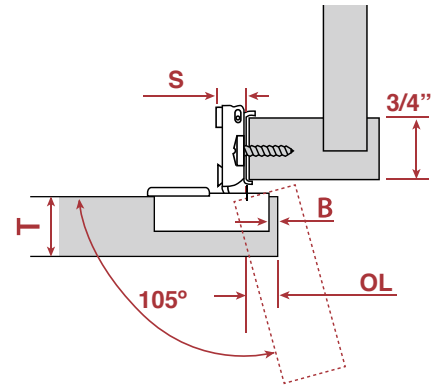

H	Overlay	P	S
5390-716	11 mm (7/16")	6 mm (1/4")	13 mm (1/2")
5390	13 mm (1/2")	3 mm (1/8")	13 mm (1/2")
5390-2-000	13 mm (1/2")	3 mm (1/8")	13 mm (1/2")
5390-6-000	19 mm (3/4")	0	13 mm (1/2")
5391-000	25.4 mm (1")	0	13 mm (1/2")
Boring distance = 3		Minimum Reveal = 7 mm (9/32")	

1-1/4" to 1-1/2" Overlay

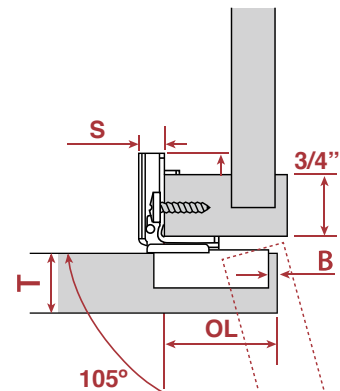

H	Overlay	P	S
5394-000	32 mm (1-1/4")	0	9 mm (11/32")
5393-000	35 mm (1-3/8")	0	9 mm (11/32")
5392-000	38 mm (1-1/2")	0	9 mm (11/32")
Boring distance = 3		Minimum Reveal = 7 mm (9/32")	

Abbreviations

H	= Item number
P	= Door protrusion
S	= Hinge arm protrusion
T	= Door thickness

Compact Hinges 4390 Series

A good balance between price and performance, the 4390 Series makes an excellent choice for an upgraded compact self-close hinge.



Features

- Designed spring and arm for better support
- Grade 2 ANSI/BHMA certified to ANSI 50,000 cycles
- One piece compact assembly with vertical screw adjustment and horizontal and depth cam adjustment

Specs

- 105 degree opening angle
- Single pivot point
- 6-way adjustability
- Cold rolled steel with nickel plating
- 45 mm boring pattern
- Compatible with 5390 Series soft-close hinges
- #7 x 5/8" pan washer head screw (7X0580WCQ) recommended



7/16" Overlay **1/2" Overlay** **3/4" Overlay** **1" Overlay** **1-1/4" Overlay** **1-3/8" Overlay** **1-1/2" Overlay**

APPLICATION



No Dowels

4390
200/ctn



**Press-in
8 mm Dowels**

4390-716 200/ctn	4390-2-000 200/ctn	4390-6-000 200/ctn	4391-000 200/ctn	4394-000 200/ctn	4393-000 200/ctn	4392-000 200/ctn
---------------------	-----------------------	-----------------------	---------------------	---------------------	---------------------	---------------------



90° Restrictor Clip 5390.RC
100 pcs/box*

*FULL BOX QUANTITIES ONLY

Application

**Face
frame**

Opening Angle

105°

Finish

**Nickel
Plating**

Adjustment

6 way

Overlay

**7/16" -
1 1/2"**

Boring Hole Pattern

45 mm

Material

Steel

Packaging

**200/
carton**

Certification

**ANSI
BHMA**

Compact Hinges 4390 Series

Compact Hinges

Three-dimensional door adjustment

Horizontal adjustment

Rotate front screw to increase or decrease door overlay.

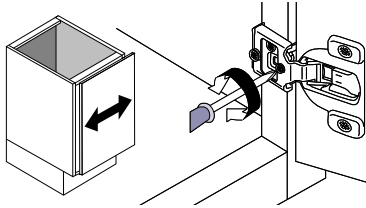

Vertical adjustment

Rotate center cam screw to adjust door position.

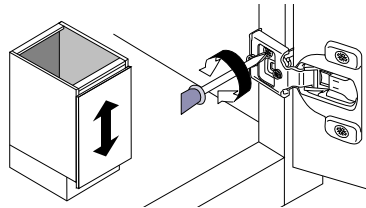

Depth adjustment

Rotate rear cam screw to adjust door position.

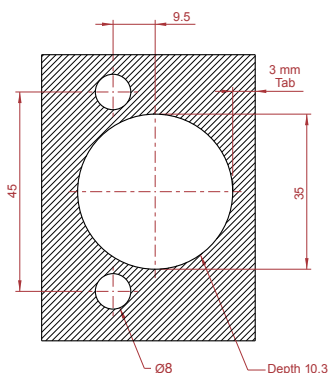
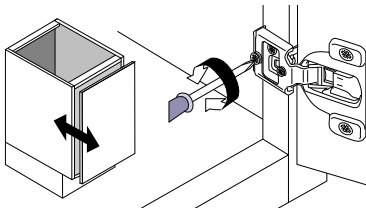

Subject to technical modifications without notice.
Dimensions in millimeters (inch equivalents as noted)

	Boring Depth	Tab
4390 Series	10.3 mm	3 mm

105° Hinges

7/16" to 1" Overlay

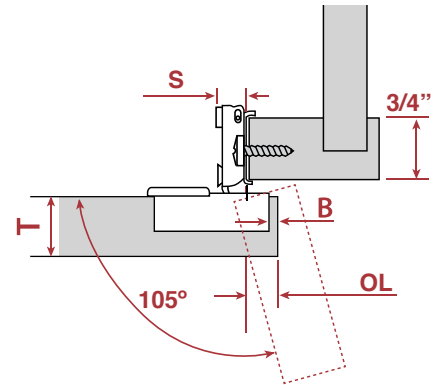

H	Overlay	P	S
4390-716	11 mm (7/16")	6 mm (1/4")	13 mm (1/2")
4390	13 mm (1/2")	3 mm (1/8")	13 mm (1/2")
4390-2-000	13 mm (1/2")	3 mm (1/8")	13 mm (1/2")
4390-6-000	19 mm (3/4")	0	13 mm (1/2")
4391-000	25.4 mm (1")	0	13 mm (1/2")
	Boring distance = 3	Minimum Reveal = 7 mm (9/32")	

1-1/4" to 1-1/2" Overlay

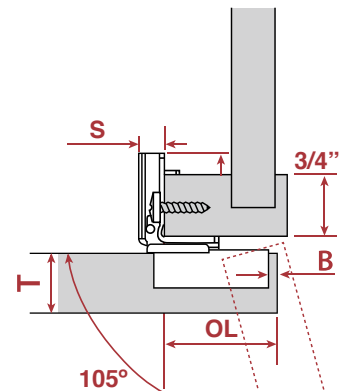

H	Overlay	P	S
4394-000	32 mm (1-1/4")	0	9 mm (11/32")
4393-000	35 mm (1-3/8")	0	9 mm (11/32")
4392-000	38 mm (1-1/2")	0	9 mm (11/32")
	Boring distance = 3	Minimum Reveal = 7 mm (9/32")	

Abbreviations

H	= Item number
P	= Door protrusion
S	= Hinge arm protrusion
T	= Door thickness

Compact Hinges 3390 Series

Hardware Resources' most economical, yet field proven compact hinge is the 3390 Series. It's hard to go wrong with this industry standard compact hinge.

Features

Grade 2 ANSI/BHMA certified to ANSI 50,000 cycles
One piece compact assembly with vertical screw adjustment and horizontal and depth cam adjustment



Specs

105 degree opening angle
Single pivot point
6-way adjustability
Cold rolled steel with nickel plating

45 mm boring pattern
#7 x 5/8" pan washer head screw (7X0580WCQ) recommended



7/16" Overlay **1/2" Overlay** **3/4" Overlay** **1" Overlay** **1-1/4" Overlay** **1-3/8" Overlay** **1-1/2" Overlay**







APPLICATION	7/16" Overlay	1/2" Overlay	3/4" Overlay	1" Overlay	1-1/4" Overlay	1-3/8" Overlay	1-1/2" Overlay
 No Dowels	3390 200/ctn						
 Press-in 8 mm Dowels	3390-716 200/ctn	3390-2-000 200/ctn	3390-6-000 200/ctn	3391-000 200/ctn	3394-000 200/ctn	3393-000 200/ctn	3392-000 200/ctn
42 mm Grass® Hole Pattern	3390-4-000 200/ctn						
 Easy-Fix Dowels	3390-3-000 200/ctn						

Application	Opening Angle
Face frame	105°

105° Compact Hinge with 4-Way Adjustment



APPLICATION	1/2" Overlay
 Press-in 8 mm Dowels	3396-000 200/ctn

Adjustment  6 way	Overlay 7/16" - 1 1/2"	Finish  Nickel Plating
Boring Hole Pattern  45 mm	Material  Steel	Certification  ANSI BHMA
	Packaging  200/carton	

Compact Hinges 3390 Series

Compact
Hinges

Three-dimensional door adjustment

Horizontal adjustment

Rotate front screw to increase or decrease door overlay.

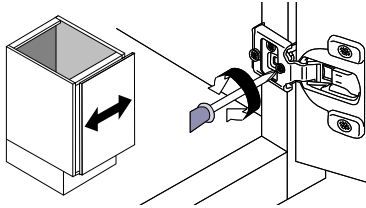

Vertical adjustment

Rotate center cam screw to adjust door position.

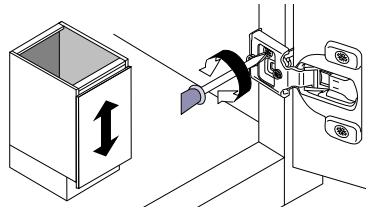

Depth adjustment

Rotate rear cam screw to adjust door position.

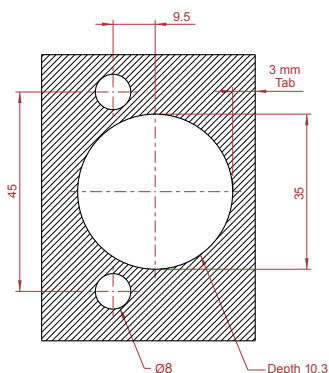
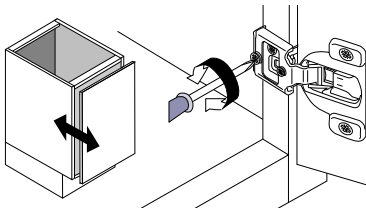

Subject to technical modifications without notice.
Dimensions in millimeters (inch equivalents as noted)

	Boring Depth	Tab
3390 Series	10.3 mm	3 mm

105° Hinges

7/16" to 1" Overlay

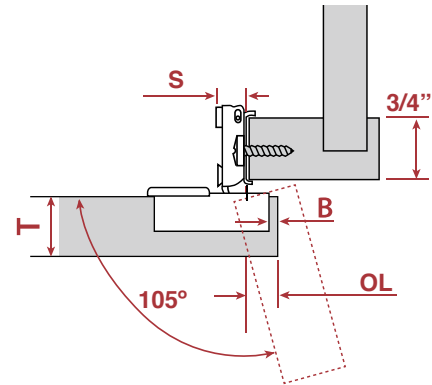

H	Overlay	P	S
3390-716	11 mm (7/16")	10 mm (13/32")	13 mm (1/2")
3390	13 mm (1/2")	5 mm (3/16")	13 mm (1/2")
3390-2-000	13 mm (1/2")	5 mm (3/16")	13 mm (1/2")
3390-6-000	19 mm (3/4")	0	13 mm (1/2")
3391-000	25.4 mm (1")	0	13 mm (1/2")
	Boring distance = 3	Minimum Reveal = 7 mm (9/32")	

1-1/4" to 1-1/2" Overlay

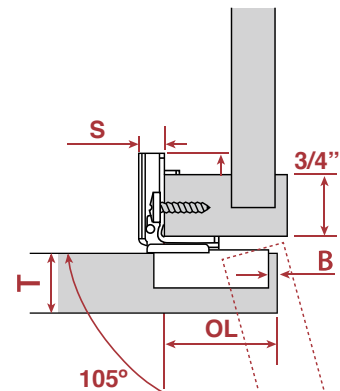

H	Overlay	P	S
3394-000	32 mm (1-1/4")	0	9 mm (11/32")
3393-000	35 mm (1-3/8")	0	9 mm (11/32")
3392-000	38 mm (1-1/2")	0	9 mm (11/32")
	Boring distance = 3	Minimum Reveal = 7 mm (9/32")	

Abbreviations

H	= Item number
P	= Door protrusion
S	= Hinge arm protrusion
T	= Door thickness

Compact Soft-close Hinges 22855 Series

This hybrid compact soft-close hinge combines the hidden damper and dual pivot point of European hinges with the compact size and convenience of a compact hinge.

Features

- Die cast face frame plate securely grasps the frame and provides two attachment points
- Grade 2 ANSI/BHMA certified to ANSI 50,000 cycles
- Built-in soft-close damper is concealed
- One piece compact assembly with vertical screw adjustment and horizontal and depth cam adjustment



Specs

- 105 degree opening angle
- Dual pivot point
- 6-way adjustability
- Cold rolled steel with nickel plating
- 45 mm boring pattern
- #6 x 5/8" pan washer head screw (6X258017Q) recommended



*1/2" Overlay
with Cam Adj Plate*

APPLICATION



No Dowels

22855-10SFT
(cam adjust)
200/ctn



*Press-in
8 mm Dowels*

22855-9SFT
(cam adjust)
200/ctn



*Press-in
8 mm Dowels*

22855-7SFT
(non-cam adjust)
200/ctn

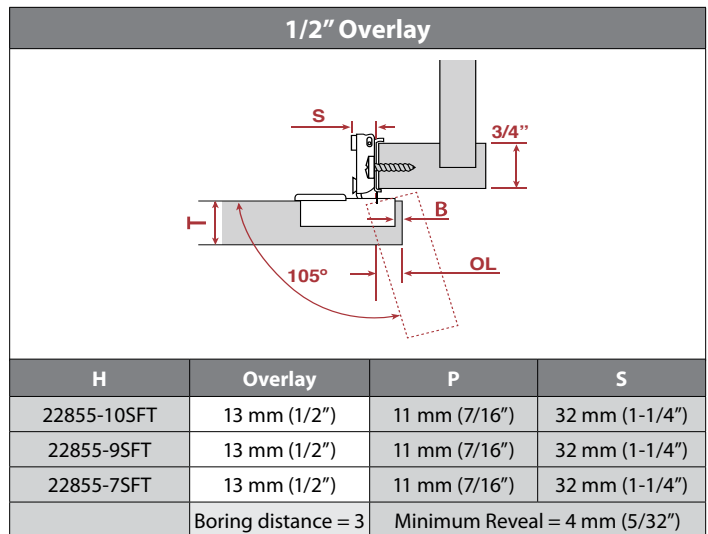

Boring Depth	Tab
12.5 mm	3 mm

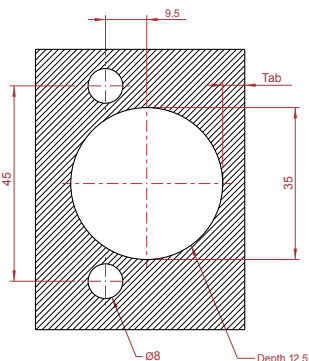

Overlay

1/2"

Application

**Face
frame**

Opening Angle

105°

Finish

**Nickel
Plating**

Adjustment

6 way

**Boring
Hole Pattern**

45 mm

Material

Steel

Packaging

**200/
carton**

Certification

**ANSI
BHMA**

Compact Hinges 22855 Series

Compact
Hinges

Combining the best of both worlds are the 22855 Series compact self-close hinges. A 125 degree opening angle and a dual pivot point make this compact hinge a good choice in any face frame cabinet.

Features

- Die cast face frame plate securely grasps the frame and provides two attachment points
- Grade 2 ANSI/BHMA certified to ANSI 50,000 cycles
- Available with or without cam adjustable plate
- One piece compact assembly with vertical screw adjustment and horizontal and depth cam adjustment

Specs

- 125 degree opening angle
- Dual pivot point
- 6-way adjustability
- Cold rolled steel with nickel plating
- 45 mm boring pattern
- #6 x 5/8" pan washer head screw (6X258017Q) recommended



1/2" Overlay
with Cam Adj Plate



1/2" Overlay



3/4" Overlay

APPLICATION



No Dowels

22855-10
200/ctn

22855-8-000N
200/ctn



Press-in
8 mm Dowels

22855-9
200/ctn

22855-7-000N
200/ctn

22855-6-000N
200/ctn

1/2" - 3/4" Overlay

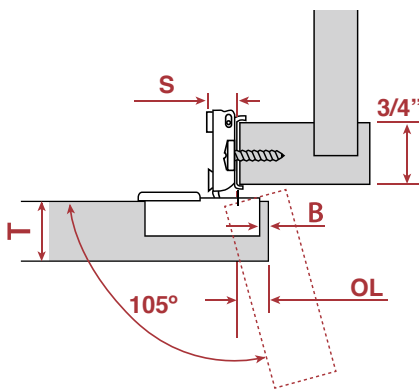

H	Overlay	P	S
22855-10	13 mm (1/2")	11 mm (7/16")	32 mm (1-1/4")
22855-8-000N	13 mm (1/2")	11 mm (7/16")	32 mm (1-1/4")
22855-9	13 mm (1/2")	11 mm (7/16")	32 mm (1-1/4")
22855-7-000N	13 mm (1/2")	11 mm (7/16")	32 mm (1-1/4")
22855-6-000N	19 mm (3/4")	8 mm (5/16")	19 mm (3/4")
Boring distance = 3		Minimum Reveal = 4 mm (5/32")	

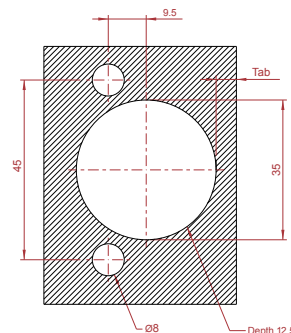

Subject to technical modifications without notice. Dimensions in millimeters (inch equivalents as noted)

Boring Depth	Tab
12.5 mm	3 mm

Compact Hinges for Cabinet Refacing 22855 Series

Designed specifically for cabinet refacers with mounting holes indexed 1/4" away from the face frame, these hinges prevent mounting screws from penetrating the seam between the reface material & the face frame.

Features

- Die cast face frame plate securely grasps the frame and provides two attachment points
- Grade 2 ANSI/BHMA certified to ANSI 50,000 cycles
- One piece compact assembly with vertical screw adjustment and horizontal and depth cam adjustment



Specs

- 125 degree opening angle
- Dual pivot point
- 6-way adjustability
- Cold rolled steel with nickel plating
- 45 mm boring pattern
- #6 x 5/8" pan washer head screw (6X258017Q) recommended

APPLICATION



No Dowels

*1/2" Overlay
with Cam Adj Plate*

22855-12
200/ctn



Easy-Fix Dowels

22855-11
200/ctn

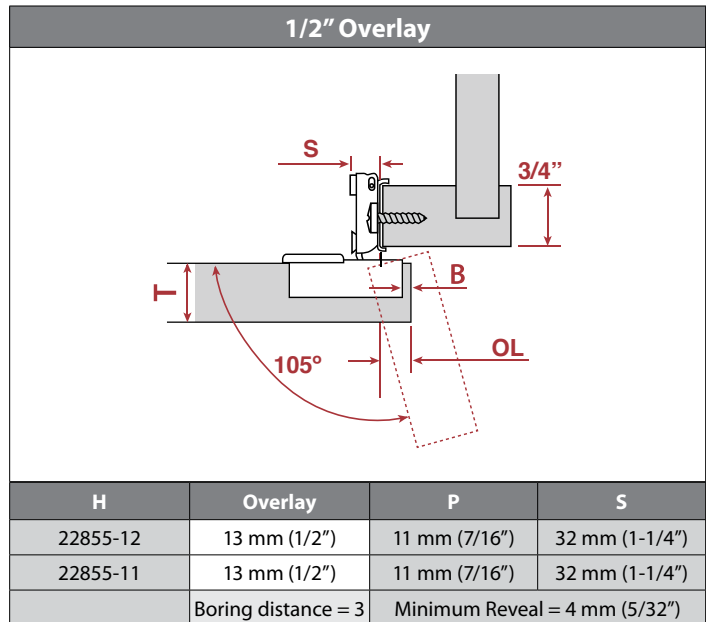

Boring Depth	Tab
12.5 mm	3 mm

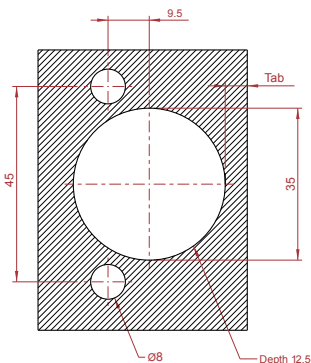

Application

Face frame

Opening Angle

125°

Finish

Nickel Plating

Adjustment

6 way

Overlay

1/2"

Boring Hole Pattern

45 mm

Material

Steel

Packaging

**200/
carton**

Certification

**ANSI
BHMA**

Soft-close Dampers

Independent Soft-close



- » One soft-close for every application
 - Face frame cabinetry (any overlay)
 - Frameless cabinetry (full overlay)
- » Mounts above the uppermost hinge using one screw
- » Pressure adjustment dial on back of device
- » Strong polymer construction with nickel plating
- » Available in bulk pack or retail pack
- » Retail pack includes #6 x 3/4" pan head screw and mounting instructions.



	<i>Bulk Packed</i>	<i>Retail Packed</i>
Nickel	ISC 200 pcs/ctn	ISC-R 40 pks/box 640 pks/master
<i>Recommended screw:</i>	<i>#6 pan head</i>	<i>screw included</i>

Clip-on Soft-close

For **500 Series** European hinges with **0 mm crank**

500.SC
500 pcs/box
1000/master

- » Available for 500 series European hinges, 22855 series compact hinges and 3390 series compact hinges

For **22855 Series** compact hinges

22855-7.SC
500 pcs/box
1000/master

- » Quickly and easily installs onto hinge body

For **22855 Series** compact hinges with **cam adjustable** plate

22855-9.SC
100 pcs/box
600/master

- » Smooth closing motion on any size cabinet door

For **3390 Series** compact hinges

3390.SC
500 pcs/box
1000/master

- » Pressure adjustment dial on back of damper
- » Average size doors only require one damper, oversize doors may require two



Hinge Accessories

90° Angle Restrictor Clips for European & Compact Hinges

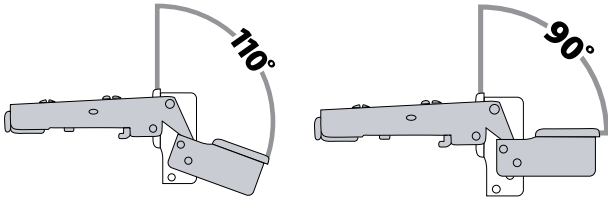

- » Convert 110° European hinges and 105°/125° compact hinges to 90°
- » Restrictor clip slips easily into the back of the cup
- » Keeps cabinet door from contacting an appliance, wall or other cabinet



90° Restrictor Clip

For 500 Series European Hinges and 22855 Soft-close Hinges	500.RC 100 pcs/box*
For 700, 725 & 900 Series European Hinges	700.RC 100 pcs/box*

*FULL BOX QUANTITIES ONLY



90° Restrictor Clip

For 5390 and 4390 Compact Hinges	5390.RC 100 pcs/box*
---	-------------------------

*FULL BOX QUANTITIES ONLY

Custom Branded Hinge Cover Caps



YOUR Logo printed in black on white plastic caps. 3 week production lead time

Hinge Cover Cap with Custom Branding

For 500 Series European Hinges	500.CAP 1000/ctn
For 700, 725 & 900 Series European Hinges	700.CAP 1000/ctn



Hinge Cover Cap with Custom Branding

For 3390 Series Compact Hinges	3390 .CAP 1000/ctn
---------------------------------------	-----------------------

Screwdriver



Screwdriver

#2 Pozzi Screwdriver with magnetized tip	HR-SCREW-DRIVER 1 pc/box
--	-----------------------------

Dowels & Screws



8 mm Dowels for Hardware Resources Hinges

276.4389.37 5000 pcs/master



Dowel Screws for Hardware Resources Hinges

828.6250.05 10,000 pcs/master

Hinge Boring & Accessories

Hinge Boring Machine



HRBORE220SP

- 220V single phase boring machine, 1.5 HP, 3450 RPM
- Single-handed operation
- Quick tab setting with dial indicator
- Board placement guide provides fast and consistent alignment
- Fully adjustable up and down speed setting
- Each machine is fine tuned and preset before shipment
- Ships preassembled with bits and long-arm European hinge ram for 500 series hinges
- Ships with tool kit
- Affordable hinge commitment program

Insertion Rams

- Solid steel construction guaranteed to last and to hold tolerances
 - Magnetic and ball bearing catches integrated into ram to hold hinge in place during insertion
 - RAM3386 compatible only with HRBORE220SP machine
- Compatible with most brands of boring machines
 - Adjustable set screws allowing adjustment of ram for all European hinges
 - Compatible with 500, 700, 725 and 900 series European hinges and 22855 series compact hinges



*Insertion Ram for
HR Boring Machine (standard)*

LARM-110



*Insertion Ram for
non-HR Boring Machines*

LARM-110B



*Insertion Ram for
700.0M73.05 165° Hinge*

LARM-165.SFT



*Insertion Ram for
3390 Series Compact Hinges*

RAM3386



*Insertion Ram for
5390 and 4390 Series Compact Hinges*

LARM-5390



*Insertion Ram for
7390 and 6390 Dura-Close® Series Hinges*

LARM-7390

Replacement Bits



8 mm Brad Bit for Dowel Hole

301008



35 mm Center Bit for Cup Hole

203351

- Solid carbide cutting edge stays sharp and precise
- Carbon alloy steel prevents corrosion and defects

Hinge Mounting Information

Determining the Number of Hinges per Door

European Hinges

Compact Hinges

Door Height

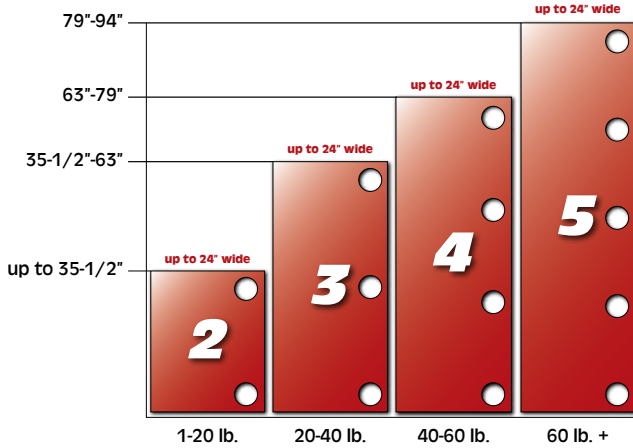

Door Height

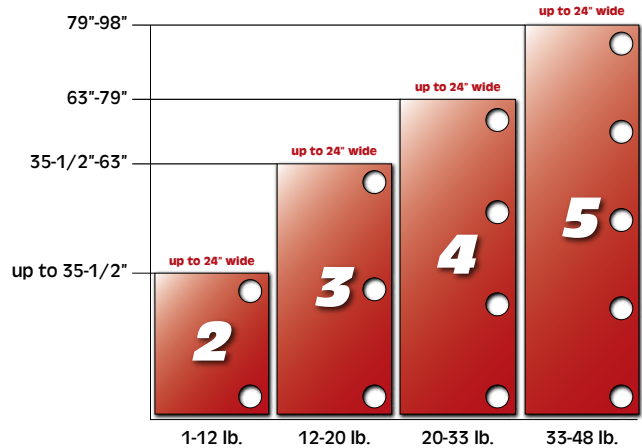

Door Weight

Door Weight

*NOTE: Avoid doors that are wider than they are tall.
Keep hinges as close to top and bottom of door as possible.
Attach hinges and plates using all available holes.*

Adjusting the Hinge

European Hinges

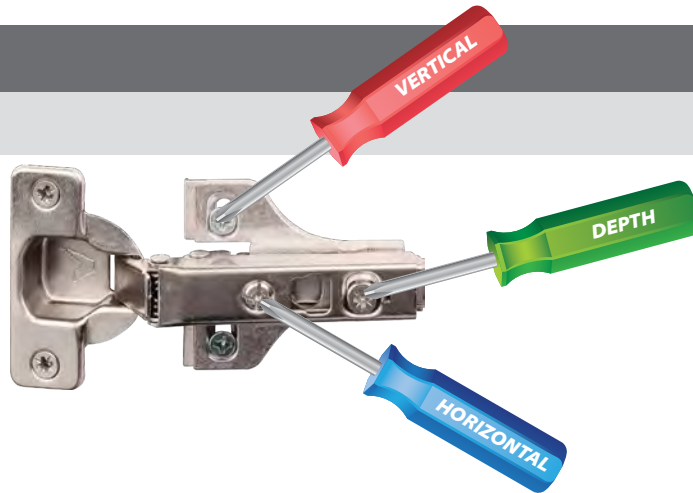

Compact Hinges

Compact Hinge - 22855 series

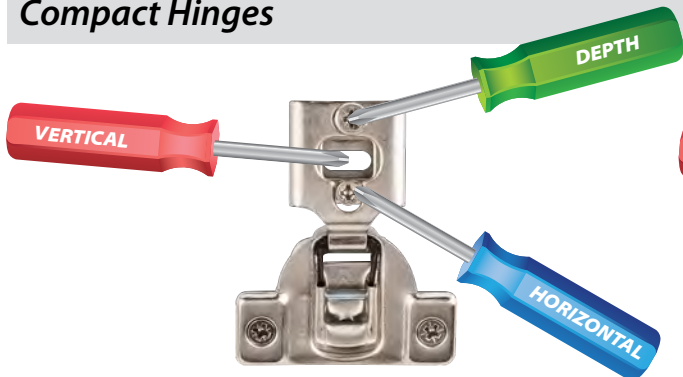

Dura-Close® Compact Soft-close Hinges

7390 Series

We're pleased to announce the next generation of Hardware Resources compact soft-close hinges, the 7390 Series Dura-Close® Compact Soft-close Hinge!

- » Superior **Dura-Close®** action provides effortless opening and a smooth, gentle close
- » Spring arm sleeves for reduced friction, wear and noise
- » Certified to **double ANSI** life cycle test: +100,000 cycles!
- » 105° opening angle
- » Works flawlessly with our 6390 Series compact hinges for soft-close on even the smallest doors
- » One-piece compact assembly with vertical screw adjustment, horizontal cam adjustment and depth cam adjustment
- » #7 x 5/8" pan washer head screw recommended for installation (item # 7X0580WCQ)
- » Four mounting cleats securely wrap around the face frame
- » Face frame application only



APPLICATION

3/8" Overlay

7/16" Overlay

1/2" Overlay

3/4" Overlay

1" Overlay

1-1/4" Overlay

1-3/8" Overlay

1-1/2" Overlay



No Dowels

7390
200/ctn

NEW



Press-in
8mm Dowels

7390-038
200/ctn

7390-716
200/ctn

7390-2-000
200/ctn

7390-6-000
200/ctn

7391-000
200/ctn

7394-000
200/ctn

7393-000
200/ctn

7392-000
200/ctn

Application

Face
frame

Opening
Angle

105°

Usage

Residential

Adjustment

6 way

Overlay

3/8" -
1 1/2"

Packaging

200/
carton

Certification

2X
ANSI
100,000+

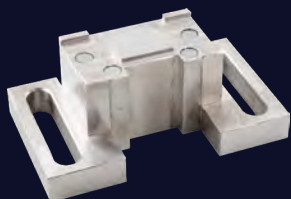

Insertion Ram for 7390 and 6390 Series
Compact Hinges

LARM-7390 **NEW**

hardware
resources®

800.463.0660

www.HardwareResources.com

Undermount Slides

Hardware Resources undermount slides provide the best options in performance and value. Smooth running, easy opening, built to last, commercial grade, best-in-class attachment clips – you'll find the perfect slide for your needs.

800.463.0660
www.HardwareResources.com

hardware
resources[®]

**Dura-Close® Heavy Duty Soft-close Slides:
USE58-300 Series**



**Heavy Duty Soft-close Slides:
USE58-100 Series**



**Commercial Grade Soft-close Slides:
USE34-100 Series**



**Standard Duty Soft-close Slides:
USE58-50 Series**



HR Series Comparison Undermount Slides



Specs Features

Series	USE58-300
Category	EZ Open Heavy Duty
Load rating*	100 lb. Dynamic
ANSI/BHMA lifecycle	75,000+
Protective spring cover: Prevents unwanted sawdust and granite dust from interfering with the soft-close mechanism	✓
Extra heavy duty steel damper: Adds protection from excessive wear and abuse	
Positive, no-worry drawer box engagement: Release clips effortlessly engage with the drawer	✓
Soft-close	✓
EZ Open: Relaxed pull force for easy opening	✓
Slotted mounting holes for micro adjustments	✓
Drawer Box Material Compatibility	1/2" - 5/8"
Lengths	9" - 24"

*Static load rating is a non-moving weight test with the specified weight over 24 hours. Dynamic load rating is more robust and includes a moving weight test with a specific weight over a set number of cycles.

HR Series Comparison Undermount Slides

Undermount
Slides

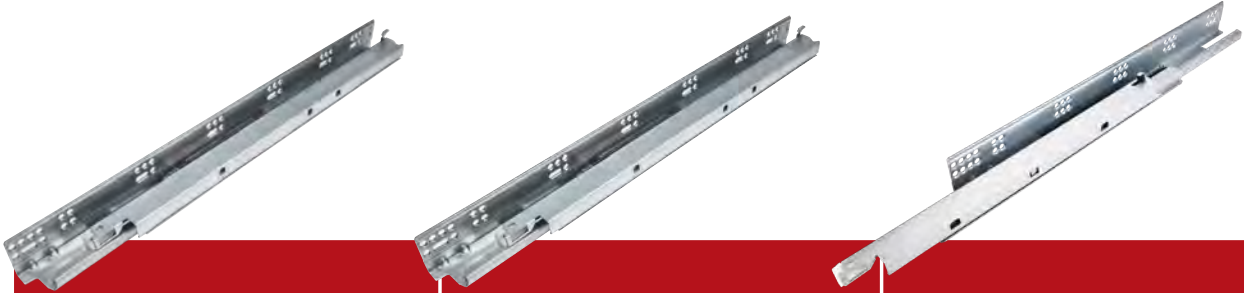

USE58-100	USE34-100	USE58-50
Heavy Duty	Heavy Duty Commercial	Standard Duty
100 lb. Dynamic	100 lb. Dynamic	100 lb. Static
100,000+	100,000+	50,000+
✓	✓	
✓	✓	✓
✓	✓	
1/2" - 5/8"	3/4"	1/2" - 5/8"
9" - 24"	12" - 21"	12" - 21"

Dura-Close® Heavy Duty Soft-close Slides USE58-300 Series

Hardware Resources' Dura-close™ Heavy Duty USE58-300 Series is the perfect choice when you want an undermount slide with the finesse sure to please any homeowner.



Features





- Relaxed pull force - 15% less than our USE58-100 Series
- Grade 1 ANSI/BHMA certified to 1.5X ANSI 75,000 cycles
- 100 lb. dynamic weight rating
- Compatible with our best-in-class line of attachment clips
- Positive, no-worry drawer box engagement

Specs

- Full extension
- Compatible with 1/2" and 5/8" drawer box material
- Screw holes for bottom mounting
- Slotted mounting holes for micro adjustments
- Clips sold separately (See page 776.)

Ordering

Slide Length (sold by the pair)	Part Number
9" Full Extension Slide	USE58-300-9
12" Full Extension Slide	USE58-300-12
15" Full Extension Slide	USE58-300-15
18" Full Extension Slide	USE58-300-18
21" Full Extension Slide	USE58-300-21
24" Full Extension Slide	USE58-300-24

Rear brackets (sold by the pair)	Part Number
 Steel Rear Bracket for Face Frame Application Slotted installation holes for vertical & horizontal adjustment	USE-STEEL 100 pr/ctn
 Steel Rear Bracket for Face Frame Application For use with the USE58-100-9 (9" undermounts only) Slotted installation holes for vertical & horizontal adjustment	USE-STEEL-9 100 pr/ctn
 Plastic Rear Bracket for Face Frame Application Dowels plug into predrilled 8 mm system holes Bracket provides wide range of lateral adjustment	USE-ADJ 250 pr/ctn
 Plastic Rear Bracket for Face Frame Application Bracket provides wide range of lateral adjustment	USE-ADJ3 250 pr/ctn
 Plastic Rear Bracket for Face Frame Application Dowels plug into predrilled 8 mm system holes Bracket provides wide range of lateral adjustment	NEW USE-ADJ5 250 pr/ctn

#6 x 5/8" pan washer head screw recommended for installation

Assume 3 mm (1/8") setback from drawer opening

Rear brackets for face frame applications, except USE-STEEL-9, will yield a 5–41 mm (3/16" - 1-5/8") depth adjustment

For inset drawer front applications:

Setback: 4 mm (5/32") + Drawer Front Thickness

For frameless cabinets, Inside Cabinet Depth Minimum = Slide Length + Setback + 3 mm (1/8")

For face frame cabinets, Inside Cabinet Depth Minimum = Slide Length + Setback + 5 mm (3/16")

Inside Cabinet Depth Maximum = Slide Length + Setback + 41 mm (1-5/8")

Travel



Dynamic Rating



Certification



Hole Pattern



Lengths



Finish



Packaging



FRONT HOLE PATTERN

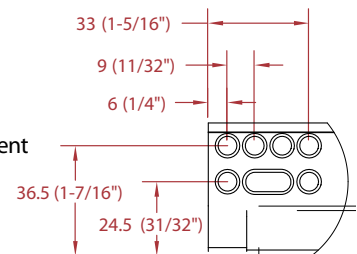

Dura-Close® Heavy Duty Soft-close Slides

USE58-300 Series

Undermount Slides

Construction & Assembly Specifications

	Slide Length	Total Cabinet Depth	Overall Drawer Length	FRAMELESS	FACE FRAME	
				Min Inside Cabinet Depth	Min Inside Cabinet Depth	Max Inside Cabinet Depth
USE58-300-9 - (9") drawer						
	10-1/4"	12"	9"	10-1/2"	10-1/2"	11-3/4"
	260 mm	305 mm	229 mm	266 mm	266 mm	299 mm
USE58-300-12 - (12") drawer						
	12-9/16"	15"	12"	12-5/8"	12-7/8"	14"
	319 mm	381 mm	305 mm	321 mm	326 mm	356 mm
USE58-300-15 - (15") drawer						
	15-5/16"	18"	15"	15-5/8"	15-7/8"	17"
	389 mm	457 mm	381 mm	397 mm	403 mm	432 mm
USE58-300-18 - (18") drawer						
	18-5/16"	21"	18"	18-3/8"	18-7/8"	20"
	465 mm	533 mm	457 mm	473 mm	479 mm	508 mm
USE58-300-21 - (21") drawer						
	21-5/16"	24"	21"	21-5/8"	21-7/8"	23"
	541 mm	610 mm	533 mm	549 mm	555 mm	584 mm
USE58-300-24 - (24") drawer						
	24-5/16"	27"	24"	24-5/8"	24-7/8"	26"
	618 mm	686 mm	610 mm	625 mm	632 mm	660 mm

DRAWER BOX MINIMUM WIDTH (VARIES BY CLIP)

	US-CLIP-6WZ	US-CLIP-6W	US-CLIP-4WZ	US-CLIP-4W	US-CLIP-2W	US-CLIP-NR
5/8" (16 mm) material	7.25"	7.25"	7.25"	7.25"	6.25"	4.75"
1/2" (13 mm) material	7"	7"	7"	7"	6"	4.5"

FRONT VIEW OF THE DRAWER INSIDE THE CABINET

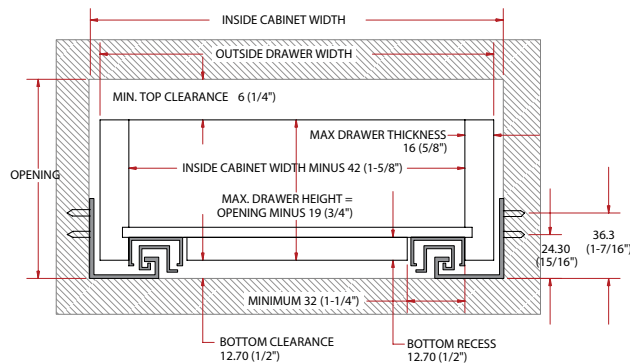

MAXIMUM DRAWER HEIGHT = OPENING MINUS 19 MM (3/4")

REAR NOTCH DIMENSIONS

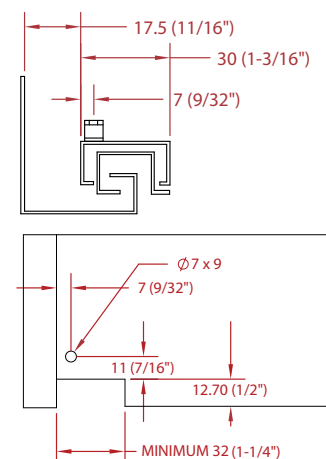

OUTSIDE DRAWER WIDTH CALCULATIONS

Drawer Side Thickness	Inside Cabinet Width Deduction
5/8" 16 mm	3/8" 10 mm
19/32" 15 mm	15/32" 12 mm
9/16" 14 mm	9/16" 14 mm
1/2" 13 mm	5/8" 16 mm
15/32" 12 mm	23/32" 18 mm

Heavy Duty Soft-close Slides USE58-100 Series

The USE58-100 Series slides were designed to have the brawn to stand up to the most rigorous of installation environments as well as almost any application.

Features

- Steel damper and dual springs for dependable and long-lasting soft-close action
- Grade 2 ANSI/BHMA certified to 2X ANSI 100,000 cycles
- 100 lb. dynamic weight rating
- Compatible with our best-in-class line of attachment clips
- Positive, no-worry drawer box engagement



Specs

- Full extension
- Compatible with 1/2" and 5/8" drawer box material
- Screw holes for bottom mounting
- Slotted mounting holes for micro adjustments
- Clips sold separately (See page 776.)

Travel



Ordering

Slide Length (sold by the pair)	Part Number
9" Full Extension Slide	USE58-100-9
12" Full Extension Slide	USE58-100-12
15" Full Extension Slide	USE58-100-15
18" Full Extension Slide	USE58-100-18
21" Full Extension Slide	USE58-100-21
24" Full Extension Slide	USE58-100-24

*Heavy Duty Slide
1/2" or 5/8" drawer box material*

Dynamic Rating



Certification



Hole Pattern



Lengths



Rear brackets (sold by the pair)	Part Number
<p>Steel Rear Bracket for Face Frame Application Slotted installation holes for vertical & horizontal adjustment</p>	USE-STEEL 100 pr/ctn
<p>Steel Rear Bracket for Face Frame Application For use with the USE58-100-9 (9" undermounts only) Slotted installation holes for vertical & horizontal adjustment</p>	USE-STEEL-9 100 pr/ctn
<p>Plastic Rear Bracket for Face Frame Application Dowels plug into predrilled 8 mm system holes Bracket provides wide range of lateral adjustment</p>	USE-ADJ 250 pr/ctn
<p>Plastic Rear Bracket for Face Frame Application Bracket provides wide range of lateral adjustment</p>	USE-ADJ3 250 pr/ctn

Finish



Packaging



#6 x 5/8" pan washer head screw recommended for installation

Assume 3 mm (1/8") setback from drawer opening

Rear brackets for face frame applications, except USE-STEEL-9, will yield a 5–41 mm (3/16" - 1-5/8") depth adjustment

For inset drawer front applications:

Setback: 4 mm (5/32") + Drawer Front Thickness

For frameless cabinets, Inside Cabinet Depth Minimum = Slide Length + Setback + 3 mm (1/8")

For face frame cabinets, Inside Cabinet Depth Minimum = Slide Length + Setback + 5 mm (3/16")

Inside Cabinet Depth Maximum = Slide Length + Setback + 41 mm (1-5/8")

FRONT HOLE PATTERN

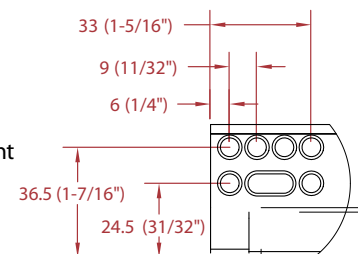

Heavy Duty Soft-close Slides USE58-100 Series

**Undermount
Slides**

Construction & Assembly Specifications

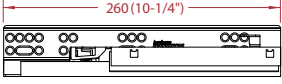
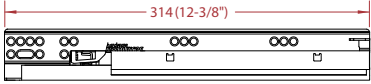
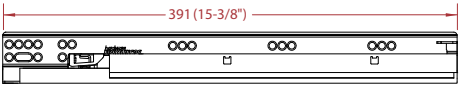
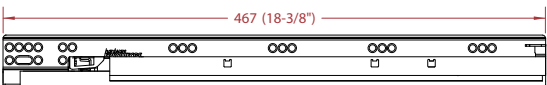
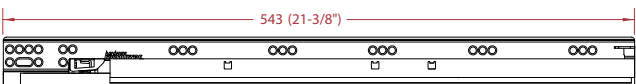
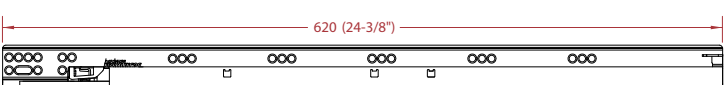
	Slide Length	Total Cabinet Depth	Overall Drawer Length	FRAMELESS	FACE FRAME	
				Min Inside Cabinet Depth	Min Inside Cabinet Depth	Max Inside Cabinet Depth
	USE58-100-9 - (9") drawer					
10-1/4" 260 mm	12" 305 mm	9" 229 mm	10-1/2" 266 mm	10-1/2" 266 mm	11-3/4" 299 mm	
	USE58-100-12 - (12") drawer					
12-3/8" 314 mm	15" 381 mm	12" 305 mm	12-5/8" 321 mm	12-7/8" 326 mm	14" 356 mm	
	USE58-100-15 - (15") drawer					
15-3/8" 391 mm	18" 457 mm	15" 381 mm	15-5/8" 397 mm	15-7/8" 403 mm	17" 432 mm	
	USE58-100-18 - (18") drawer					
18-3/8" 467 mm	21" 533 mm	18" 457 mm	18-3/8" 473 mm	18-7/8" 479 mm	20" 508 mm	
	USE58-100-21 - (21") drawer					
21-3/8" 543 mm	24" 610 mm	21" 533 mm	21-5/8" 549 mm	21-7/8" 555 mm	23" 584 mm	
	USE58-100-24 - (24") drawer					
24-3/8" 620 mm	27" 686 mm	24" 610 mm	24-5/8" 625 mm	24-7/8" 632 mm	26" 660 mm	

DRAWER BOX MINIMUM WIDTH (VARIES BY CLIP)

	US-CLIP-6WZ	US-CLIP-6W	US-CLIP-4WZ	US-CLIP-4W	US-CLIP-2W	US-CLIP-NR
5/8" (16 mm) material	7.25"	7.25"	7.25"	7.25"	6.25"	4.75"
1/2" (13 mm) material	7"	7"	7"	7"	6"	4.5"

FRONT VIEW OF THE DRAWER INSIDE THE CABINET

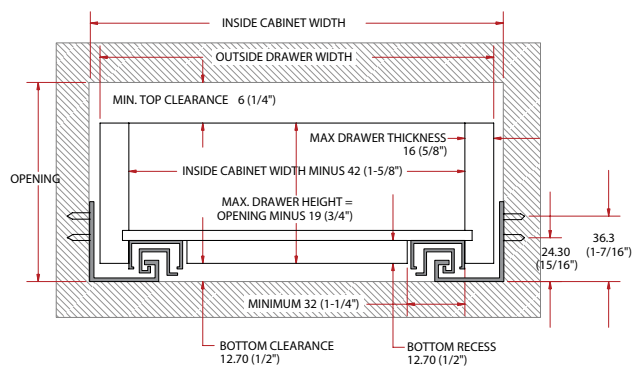

MAXIMUM DRAWER HEIGHT = OPENING MINUS 19 MM (3/4")

REAR NOTCH DIMENSIONS

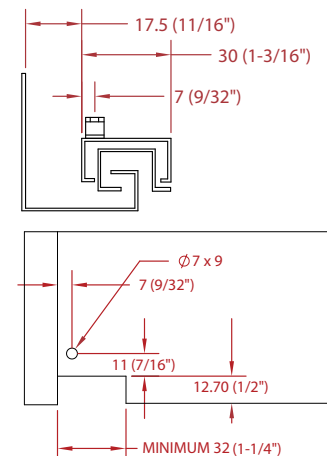

OUTSIDE DRAWER WIDTH CALCULATIONS

Drawer Side Thickness	Inside Cabinet Width Deduction
5/8" 16 mm	3/8" 10 mm
19/32" 15 mm	15/32" 12 mm
9/16" 14 mm	9/16" 14 mm
1/2" 13 mm	5/8" 16 mm
15/32" 12 mm	23/32" 18 mm

Commercial Grade Soft-close Slides USE34-100 Series

For commercial applications requiring 3/4" drawer boxes, you need a slide built specifically for the job. Hardware Resources' USE34-100 Series is just the slide for that.

Features

- Steel damper and dual springs for dependable and long-lasting soft-close action
- Grade 2 ANSI/BHMA certified to 2X ANSI 100,000 cycles
- 100 lb. dynamic weight rating
- Compatible with our best-in-class line of attachment clips
- Positive, no-worry drawer box engagement

Specs

- Full extension
- Compatible with 3/4" drawer box material
- Screw holes for bottom mounting
- Slotted mounting holes for micro adjustments
- Clips sold separately (See page 776.)



Ordering

Slide Length (sold by the pair)	Part Number
12" Full Extension Slide	USE34-100-12
15" Full Extension Slide	USE34-100-15
18" Full Extension Slide	USE34-100-18
21" Full Extension Slide	USE34-100-21

*Commercial Grade Heavy Duty Slide
3/4" drawer box material*

Travel





Dynamic Rating



Certification



Rear brackets (sold by the pair)	Part Number
 <p>Steel Rear Bracket for Face Frame Application Slotted installation holes for vertical & horizontal adjustment</p>	USE-STEEL 100 pr/ctn
 <p>Plastic Rear Bracket for Face Frame Application Dowels plug into predrilled 8 mm system holes Bracket provides wide range of lateral adjustment</p>	USE-ADJ 250 pr/ctn
 <p>Plastic Rear Bracket for Face Frame Application Bracket provides wide range of lateral adjustment</p>	USE-ADJ3 250 pr/ctn

Hole Pattern



Lengths



Finish



Packaging



#6 x 5/8" pan washer head screw recommended for installation.

Commercial Grade Soft-close Slides USE34-100 Series

**Undermount
Slides**

Construction & Assembly Specifications

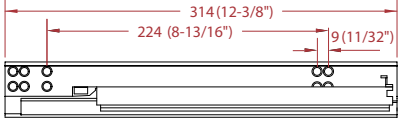
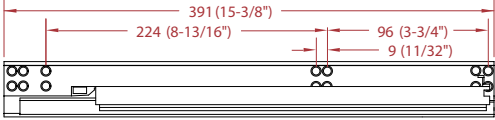
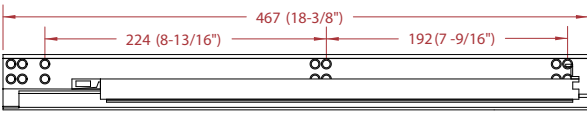
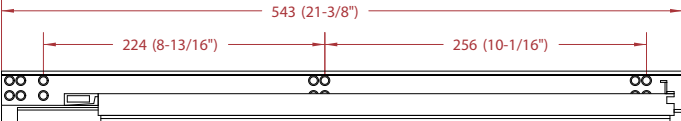
			FRAMELESS	FACE FRAME	
Slide Length	Total Cabinet Depth	Overall Drawer Length	Min Inside Cabinet Depth	Min Inside Cabinet Depth	Max Inside Cabinet Depth
			USE34-100-12 - (12") drawer		
12-3/8"	15"	12"	12-5/8"	12-7/8"	14"
314 mm	381 mm	305 mm	321 mm	326 mm	356 mm
			USE34-100-15 - (15") drawer		
15-3/8"	18"	15"	15-5/8"	15-7/8"	17"
391 mm	457 mm	381 mm	397 mm	403 mm	432 mm
			USE34-100-18 - (18") drawer		
18-3/8"	21"	18"	18-3/8"	18-7/8"	20"
467 mm	533 mm	457 mm	473 mm	479 mm	508 mm
			USE34-100-21 - (21") drawer		
21-3/8"	24"	21"	21-5/8"	21-7/8"	23"
543 mm	610 mm	533 mm	549 mm	555 mm	584 mm

Assume 8 mm (5/16") setback from drawer opening

Rear brackets for face frame applications will yield a 5–41 mm (3/16" - 1-5/8") depth adjustment

For inset drawer front applications:

Setback: 8 mm (5/16") + Drawer Front Thickness

For frameless cabinets, Inside Cabinet Depth Minimum = Slide Length + Setback + 3 mm (1/8")

For face frame cabinets, Inside Cabinet Depth Minimum = Slide Length + Setback + 5 mm (3/16")

Inside Cabinet Depth Maximum = Slide Length + Setback + 41 mm (1-5/8")

OUTSIDE DRAWER WIDTH CALCULATIONS

Drawer Side Thickness	Inside Cabinet Width Deduction
3/4" 19 mm	1/2" 13 mm

DRAWER BOX MINIMUM WIDTH (VARIES BY CLIP)

	US-CLIP-6WZ	US-CLIP-6W	US-CLIP-4WZ	US-CLIP-4W	US-CLIP-2W	US-CLIP-NR
3/4" (19 mm) material	7.5"	7.5"	7.5"	7.5"	6.5"	5-25"

FRONT VIEW OF THE DRAWER INSIDE THE CABINET

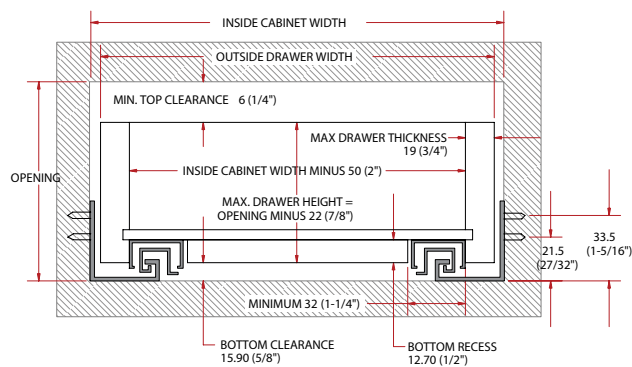

MAXIMUM DRAWER HEIGHT = OPENING MINUS 22 MM (7/8")

REAR NOTCH DIMENSIONS

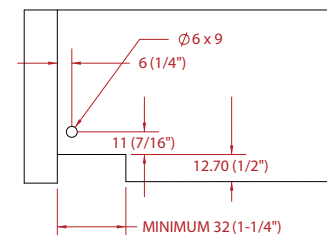
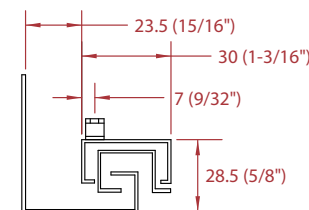

FRONT HOLE PATTERN

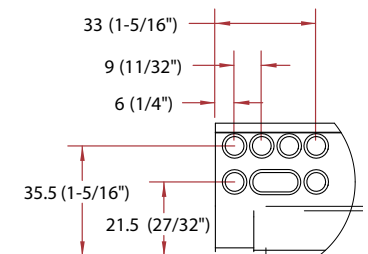

Standard Duty Soft-close Slides USE58-50 Series

Hardware Resources' standard duty 100 lb soft-close undermount makes the perfect slide for your everyday residential cabinet needs. Sold with or without clips, it's hard to go wrong with these slides.

Features

- Grade 1 ANSI/BHMA certified to ANSI 50,000 cycles
- 100 lb. dynamic weight rating
- Compatible with our best-in-class line of attachment clips
- Positive, no-worry drawer box engagement





Specs

- Full extension
- Compatible with 1/2" and 5/8" drawer box material
- Sold either with clips (USExx) or without clips (USE-50-xx)



Ordering

Slide Length (sold by the pair)	<i>Slide only</i> 1/2" or 5/8" drawer box material	<i>Slide + US-CLIP-2W</i> 1/2" or 5/8" drawer box material
	Part Number	Part Number
12" Full Extension Slide	USE58-50-12	USE12
15" Full Extension Slide	USE58-50-15	USE15
18" Full Extension Slide	USE58-50-18	USE18
21" Full Extension Slide	USE58-50-21	USE21

Rear brackets & Accessories (brackets sold by the pair)	Part Number
 <p>Steel Rear Bracket for Face Frame Application Slotted installation holes for vertical & horizontal adjustment</p>	USE-STEEL 100 pr/ctn
 <p>Plastic Rear Bracket for Face Frame Application Dowels plug into predrilled 8 mm system holes Bracket provides wide range of lateral adjustment</p>	USE-ADJ 250 pr/ctn
 <p>Plastic Rear Bracket for Face Frame Application Bracket provides wide range of lateral adjustment</p>	USE-ADJ3 250 pr/ctn
 <p>Slide Mounting Kit (4 Zinc L-brackets & attachment screws) Mount slides directly to cabinet floor or fixed shelf Threaded collars mean secure slide attachment using only a screwdriver and included screws</p>	SLIDE-KIT 50 pks/ctn

#6 x 5/8" pan washer head screw recommended for installation.

Travel



Dynamic Rating



Certification



Hole Pattern



Lengths



Finish



Packaging



Standard Duty Soft-close Slides USE58-50 Series

**Undermount
Slides**

Construction & Assembly Specifications

				FRAMELESS	FACE FRAME	
	Slide Length	Total Cabinet Depth	Overall Drawer Length	Min Inside Cabinet Depth	Min Inside Cabinet Depth	Max Inside Cabinet Depth
<p>USE12 305 (12") drawer</p>	12-1/2" 318 mm	15" 381 mm	12" 305 mm	12-5/8" 321 mm	12-7/8" 326 mm	14-9/16" 369 mm
<p>USE15 381 (15") drawer</p>	15-1/2" 394 mm	18" 457 mm	15" 381 mm	15-11/16" 398 mm	15-7/8" 403 mm	17-9/16" 446 mm
<p>USE18 457 (18") drawer</p>	18-1/2" 470 mm	21" 533 mm	18" 457 mm	18-11/16" 474 mm	18-7/8" 479 mm	20-9/16" 522 mm
<p>USE21 533 (21") drawer</p>	21-1/2" 546 mm	24" 610 mm	21" 533 mm	21-11/16" 550 mm	21-7/8" 555 mm	23-9/16" 598 mm

Assume 3 mm (1/8") setback from drawer opening

Rear brackets for face frame applications will yield a 5–48 mm (3/16" - 1-7/8") depth adjustment

For inset drawer front applications:

Setback: 5 mm (3/16") + Drawer Front Thickness

For frameless cabinets, Inside Cabinet Depth Minimum = Slide Length + Setback + 3 mm (1/8")

For face frame cabinets, Inside Cabinet Depth Minimum = Slide Length + Setback + 5 mm (3/16")

Inside Cabinet Depth Maximum = Slide Length + Setback + 48 mm (1-5/16")

FRONT HOLE PATTERN

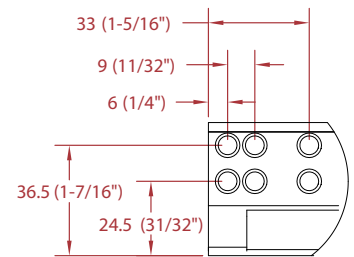

FRONT VIEW OF THE DRAWER INSIDE THE CABINET

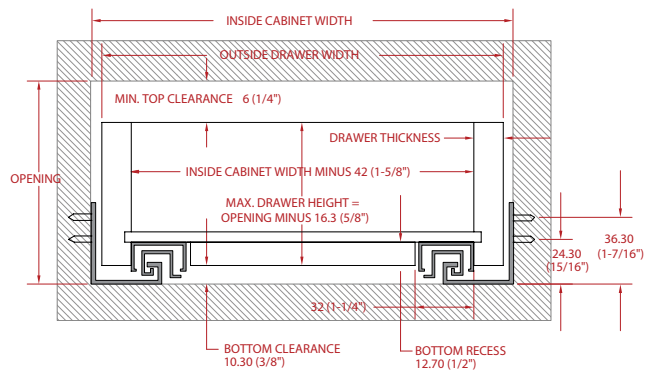

MAXIMUM DRAWER HEIGHT = OPENING MINUS 19 MM (3/4")

REAR NOTCH DIMENSIONS

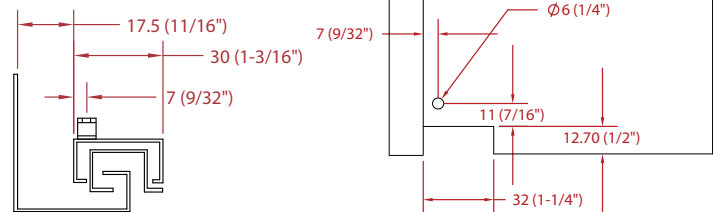

OUTSIDE DRAWER WIDTH CALCULATIONS

Drawer Side Thickness	5/8"	19/32"	9/16"	1/2"	15/32"
	16 mm	15 mm	14 mm	13 mm	12 mm
Inside Cabinet Width Deduction	3/8"	15/32"	9/16"	5/8"	23/32"
	10 mm	12 mm	14 mm	16 mm	18 mm

Undermount Release Clips

6-Way Heavy Duty Adjustable Clip with Zinc Base



- *Vertical adjustment: Up to 3 mm (1/8")*
- *Horizontal adjustment: +/- 2 mm (5/64")*
- *Depth adjustment: Up to 2.5 mm (3/32")*
- *For inset applications*
- *Heavy duty die cast zinc base*

Description	Part Number	Ctn Qty
6-way adjustable clip with zinc base	US-CLIP-6WZ	200/ctn Packaged by pair (L/R)

6-Way Standard Duty Adjustable Clip



- *Vertical adjustment: Up to 3 mm (1/8")*
- *Horizontal adjustment: +/- 2 mm (5/64")*
- *Depth adjustment: Up to 2.5 mm (3/32")*
- *For inset applications*

Description	Part Number	Ctn Qty
6-way adjustable clip	US-CLIP-6W	200/ctn Packaged by pair (L/R)

4-Way Heavy Duty Adjustable Clip with Zinc Base



- *Vertical adjustment: Up to 3 mm (1/8")*
- *Horizontal adjustment: +/- 2 mm (5/64")*
- *Heavy duty die cast zinc base*

Description	Part Number	Ctn Qty
4-way adjustable clip with zinc base	US-CLIP-4WZ	200/ctn Packaged by pair (L/R)

4-Way Standard Duty Adjustable Clip



- *Vertical adjustment: Up to 3 mm (1/8")*
- *Horizontal adjustment: +/- 2 mm (5/64")*

Description	Part Number	Ctn Qty
4-way adjustable clip	US-CLIP-4W	200/ctn Packaged by pair (L/R)

DRAWER BOX MINIMUM WIDTH (VARIES BY CLIP)

	US-CLIP-6WZ	US-CLIP-6W	US-CLIP-4WZ	US-CLIP-4W	US-CLIP-2W	US-CLIP-NR
5/8" (16mm) material	7.25"	7.25"	7.25"	7.25"	6.25"	4.75"
1/2" (13mm) material	7"	7"	7"	7"	6"	4.5"

#6 x 5/8" pan head screw recommended for installation

Undermount Release Clips

2-Way Adjustable Narrow Clip



- *Vertical adjustment: Up to 3 mm (1/8")*
- *Minimum drawer box width for 1/2" material (4-1/2")*
- *Minimum drawer box with for 5/8" material (4-3/4")*

Description	Part Number	Ctn Qty
2-way adjustable clip	US-CLIP-NR	100/ctn Packaged by pair (L/R)

2-Way Adjustable Clip

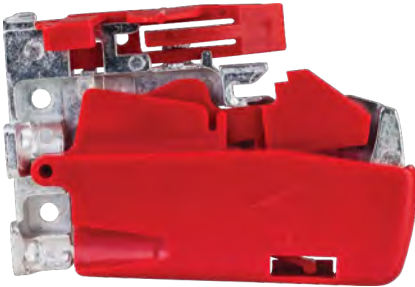

- *Vertical adjustment: Up to 3 mm (1/8")*
- *Die cast zinc base*

Description	Part Number	Ctn Qty
2-way adjustable clip	US-CLIP-2W	200/ctn Packaged by pair (L/R)

DRAWER BOX MINIMUM WIDTH (VARIES BY CLIP)

	US-CLIP-6WZ	US-CLIP-6W	US-CLIP-4WZ	US-CLIP-4W	US-CLIP-2W	US-CLIP-NR
5/8" (16mm) material	7.25"	7.25"	7.25"	7.25"	6.25"	4.75"
1/2" (13mm) material	7"	7"	7"	7"	6"	4.5"

#6 x 5/8" pan head screw recommended for installation



Undermount Shelf Bracket

Attach rear mounting block to the back of the shelf instead of notching and boring.



NEW



Undermount Shelf Bracket

Black USE-RMB

250 pcs/ctn

- » For use with USE58-300, USE58-100, USE58-50 or USE34-100 undermount slides
- » Maximum apron thickness 16 mm (5/8") for USE58 series slides
- » Maximum apron thickness 19 mm (3/4") for USE34 series slides
- » One pair of drawer clips are required per shelf
- » Installation screws are provided

MOUNTING SPECIFICATIONS

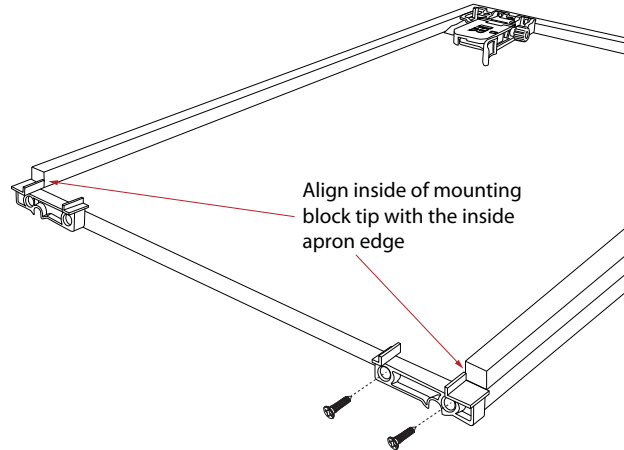
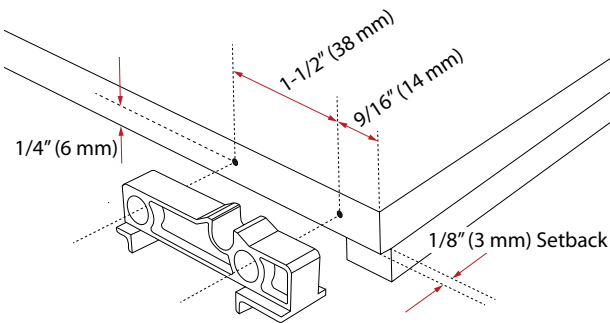

FRONT VIEW OF THE SHELF INSIDE THE CABINET

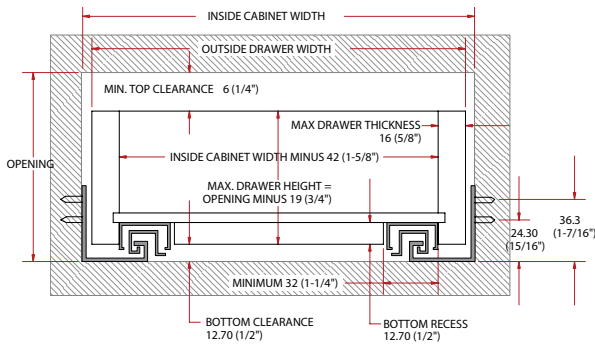

OUTSIDE SHELF WIDTH CALCULATIONS

Drawer Side Thickness	Inside Cabinet Width Deduction
5/8"	3/8"
16 mm	10 mm
19/32"	15/32"
15 mm	12 mm
9/16"	9/16"
14 mm	14 mm
1/2"	5/8"
13 mm	16 mm
15/32"	23/32"
12 mm	18 mm

NOTE: Shelf length = length of slide minus 13/32" (10 mm)

Dura-Close® Heavy Duty Soft-close Slides

USE58-300 Series

We're pleased to announce the next evolution of Hardware Resources undermount slides, the 300 Series Dura-Close® Undermount Slide!

We've taken our very successful undermount slides and refined the action to provide a more relaxed opening force, super smooth performance and extremely quiet movement – all while maintaining a robust 100lb dynamic weight rating with 1.5X the ANSI/BHMA-required cycles!

Clips sold separately

- Relaxed pull force makes drawer opening seemingly effortless
- Smoothest and quietest Hardware Resources slide ever
- Custom spring cover keeps springs debris free
- Positive, no-worry drawer box engagement
- No minimum opening before soft-close engages
- Compatible with our best-in-class line of undermount clip options
- Tested to 1.5X ANSI/BHMA life cycle requirement, 100lbs for 75,000 cycles

Load Rating



Certification



Lengths



Packaging



Ordering (Packaged 6 pair per box)	<i>Dura-Close® Heavy Duty Slide</i> 1/2" or 5/8" drawer box material
Slide Length (sold by the pair)	Part Number
9" Full Extension Slide	USE58-300-9
12" Full Extension Slide	USE58-300-12
15" Full Extension Slide	USE58-300-15 NEW
18" Full Extension Slide	USE58-300-18 NEW
21" Full Extension Slide	USE58-300-21 NEW
24" Full Extension Slide	USE58-300-24

800.463.0660

www.HardwareResources.com



Contact your Hardware Resources Sales Representative for more information.

To learn more, scan the QR code with your smartphone or mobile device or visit <http://delivr.com/25gnj>

hardware
resources®

Heavy Duty Metal Drawer Box System

MDB-086 and MDB-164 Series

Upgraded, sleek metal drawer box system for higher-end commercial and residential applications. The high gloss white finish looks great in any cabinet.

NEW

Shown assembled as MDB-086-500.



Wooden parts not included with standard metal drawer box system.

Features

- Front cams provide vertical and horizontal drawer front adjustment
- Grade 1 ANSI/BHMA certified to 50,000 cycles
- 100 lb. dynamic weight rating
- Release cam for easy drawer front removal

Specs

- Full extension
- Recommended 5/8" material for drawer bottom and back
- 10 mm dowels for drawer front installation
- MDB-164 Series adds two galley rails and a taller rear bracket for taller drawer applications
- White powder coat finish
- Available in metric lengths
- Frameless applications only

Ordering

MDB-086-400 4 pr/ctn	86 mm height 400 mm length	
MDB-086-450 4 pr/ctn	86 mm height 450 mm length	
MDB-086-500 4 pr/ctn	86 mm height 500 mm length	
MDB-086-550 4 pr/ctn	86 mm height 550 mm length	
MDB-164-400 4 pr/ctn	164 mm height 400 mm length	
MDB-164-450 4 pr/ctn	164 mm height 450 mm length	
MDB-164-500 4 pr/ctn	164 mm height 500 mm length	
MDB-164-550 4 pr/ctn	164 mm height 550 mm length	

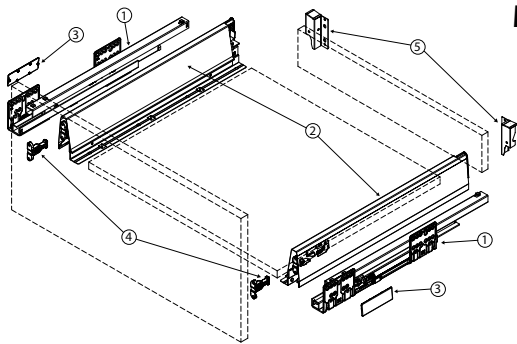

MDB-086

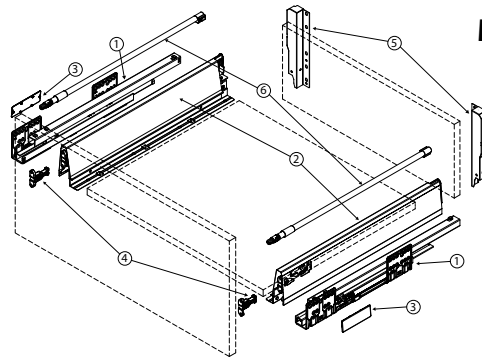

MDB-164

1	Cabinet profiles: (L/R)	2X	4	Front fixing bracket	2X
2	Drawer profiles: (L/R)	2X	5	Rear connecting bracket (L/R)	2X
3	Side cover plate	2X	6	Galley Rail (MDB-164-xxx only)	2X

Heavy Duty Metal Drawer Box System

MDB-086 and MDB-164 Series

Metal Drawer Boxes

Part Dimensions				
Item No.	Item No.	Nominal length	Internal drawer length	Min. installation length of drawer
MDB-086-400	MDB-164-400	400 mm	374 mm	410 mm
MDB-086-450	MDB-164-450	450 mm	424 mm	460 mm
MDB-086-500	MDB-164-500	500 mm	474 mm	510 mm
MDB-086-550	MDB-164-550	550 mm	524 mm	560 mm

MDB-086	Dimensions	<p>Dimensions of cabinet</p>	<p>Front fixing bracket</p>	<p>Drilling hole on drawer front</p>	<p>Drawer back</p>
	Slide Dimensions	<p>Nominal: 400/450/500/550 mm</p>			
MDB-164	Dimensions	<p>Dimensions of cabinet</p>	<p>Front fixing bracket</p>	<p>Drilling hole on drawer front</p>	<p>Drawer back</p>
	Slide Dimensions	<p>Nominal: 400/450/500/550 mm</p>			

Soft-close Metal Drawer Box System USE Series

Standard duty metal drawer box system convenient for a variety of applications.

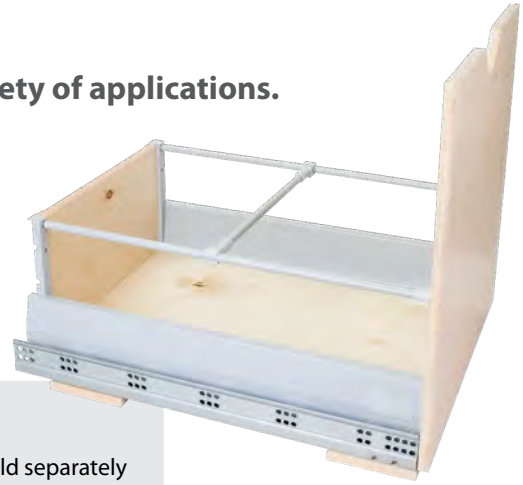

Features

- Front cams provide vertical and horizontal drawer front adjustment
- 100 lb. dynamic weight rating
- Release cam for easy drawer front removal

Specs

- Full extension
- Grey powder coat finish
- Recommended 5/8" material for drawer bottom and back
- Height extension kits sold separately
- Screw-on front bracket for drawer front attachment
- Frameless or face frame applications

Shown assembled as CAN-MDB. Wooden parts not included with standard metal drawer box system.

USE12-MDB 5 pr/ctn	12" Full Extension Metal Drawer Box Kit		<p>Heavy duty 100 lb. load capacity One pair includes slides, release clips, grey drawer sides, drawer front fixing brackets, drawer back fixing brackets and mounting hardware Use Phillips screwdriver for adjustment (see picture left) Optional height extension kit available with cross rail connectors Use 5/8" thick material for building the drawer back and drawer bottom</p>
USE15-MDB 5 pr/ctn	15" Full Extension Metal Drawer Box Kit		
USE18-MDB 5 pr/ctn	18" Full Extension Metal Drawer Box Kit		
USE21-MDB 5 pr/ctn	21" Full Extension Metal Drawer Box Kit		

USE12-MDB-ROD 50/ctn	12" Drawer Height Extension Kit		<p>Used in addition to the full extension metal drawer box kit Extends total drawer back height to 7-13/16" Two gallery rails and two extended back plates included in each kit Creates a deep drawer — perfect for pots, pans, plates and storage of various kitchen items Shown with optional cross rail connectors</p>
USE15-MDB-ROD 50/ctn	15" Drawer Height Extension Kit		
USE18-MDB-ROD 50/ctn	18" Drawer Height Extension Kit		
USE21-MDB-ROD 50/ctn	21" Drawer Height Extension Kit		

USE-MDB-1 100 pr/ctn	Single Cross Rail Connector		<p>Used in addition to the full extension metal drawer box kit Used in conjunction with the drawer height extension kit Creates a single or double cross rail divider in the drawer Slides along the gallery rail and tightens into place 700 mm cross rail is cut by customer according to the drawer width</p>
USE-MDB-2 100 pr/ctn	Double Cross Rail Connector		
USE-MDB-RAIL 100/ctn	700 mm Cross Rail for Metal Drawer Box Connectors		

Drawer bottom length
= inside cabinet length - 18 mm (23/32")
Drawer bottom width
= inside cabinet width - 111 mm (4-3/8")

Drawer back height:	
Regular system = 67 mm	Using Extension Kit = 167 mm
Drawer back width	
= inside cabinet width - 119 mm (4-11/16")	

Slide and Hinge Installation Tool HR-TOOL-300

Drawer Slide
Accessories



- Each kit includes:**
- » Mounting Jig
 - » 7 mm Drill Bit
 - » Drill Bit Depth Collar
 - » Allen Wrench
 - » 2.5 mm Drill Bit

Ordering

Description	Part Number
Slide and Hinge Installation Tool	HR-TOOL-300

Drilling Location for Rear Hook Hole on Drawer Box; Left and Right

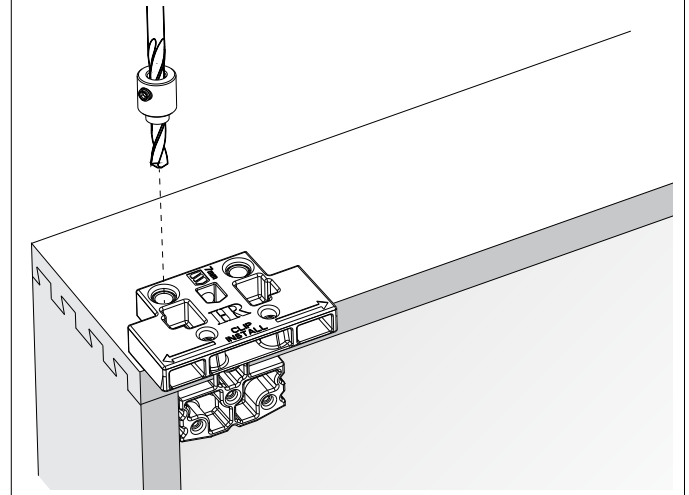

Drilling Location for Hardware Resources Undermount Slide Clip

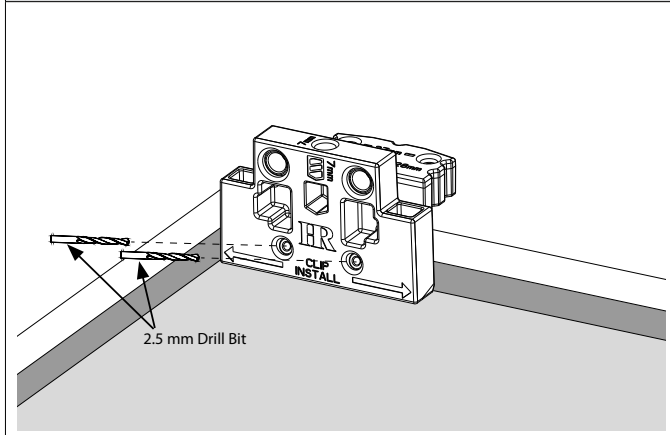

Drill Locations for Compact Hinge on Face Frame Cabinets

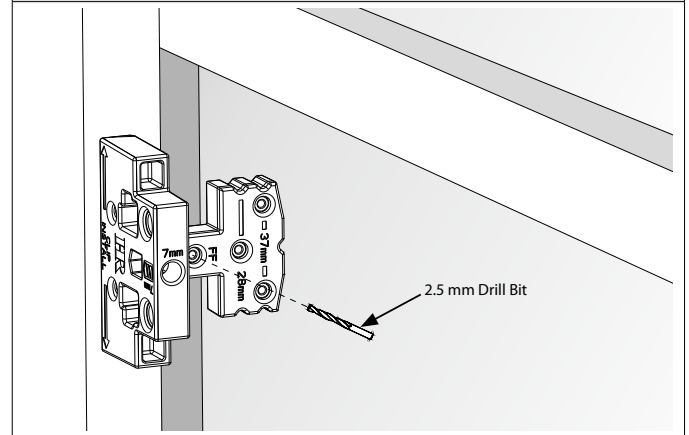

"V" Notches for Frameless Hinge Plate Holes at 28 mm and 37 mm Setback

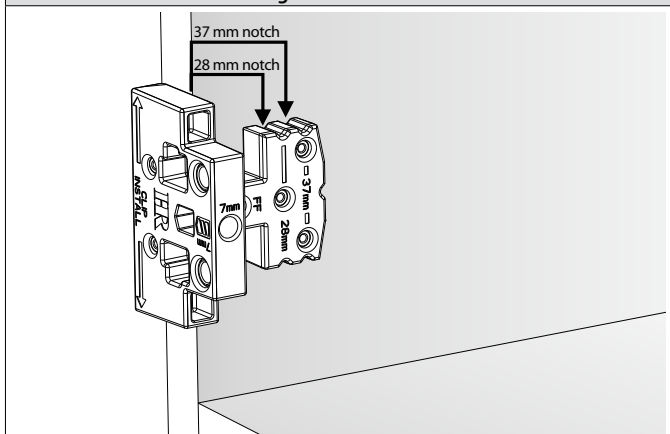

Drill Locations for Hinge Plates in Frameless Cabinets with 37 mm Setback

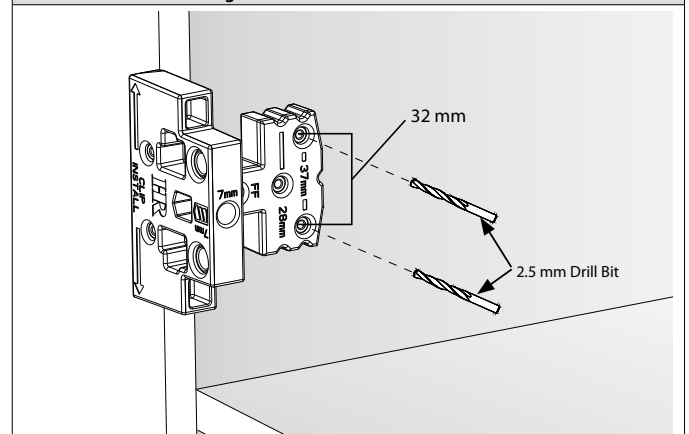

Ball Bearing Slides

Hardware Resources is proud to offer a wide selection of ball bearing slides to meet the needs of almost any customer. Whether it's an extra heavy duty 225 lb. slide, a 75 lb. slide or anything in between, including soft-close and push-to-open options, you'll find them here.

800.463.0660
www.HardwareResources.com

hardware
resources[®]

**EZ Open Heavy Duty Soft-close Slides:
303-300 Series**



[788]

**Heavy Duty Soft-close Slides:
303FUSFT Series**



[790]

**Commercial Grade Heavy Duty Slides:
209FU Series - 1" Overtravel**

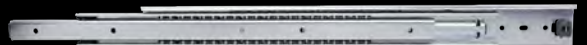

[792]

**Extra Heavy Duty Slides:
300FU Series**



[794]

**Heavy Duty Slides:
301FU Series - 1/2" Overtravel**



[796]

**Heavy Duty Slides:
303FU Series**



[798]

**100 lb. Standard Duty Slides:
303-50 Series**



[800]

**Push-to-Open Slides:
303FUPT Series**



[802]

**Medium Duty Slides - 36 mm:
307FU Series**



[804]

HR Series Comparison

Ball Bearing Slides



Features

Specs

	Soft-Close		Extra Heavy Duty	
Series	303-300	303FUSFT	209FU	300FU
Category	EZ Open Soft-Close	Most Robust Soft-Close	Extra Heavy Duty 225 lb.	Extra Heavy Duty 150 lb.
ANSI/BHMA Grade 1 load rating*	100 lb. Static	100 lb. Dynamic	225 lb. Dynamic	150 lb. Dynamic
Over travel: For added drawer accessibility with overhanging countertops			1"	
EZ Open: Relaxed pull force for easy opening	✓			
Profile height	45 mm	45 mm	54 mm	2" (51 mm)
Soft-close/Push-to-open	Soft-close	Soft-close		
Face frame or frameless cabinet compatibility	Both	Both	Frameless only	Frameless only
Lengths	10" – 28"	12" – 28"	16" – 30"	12" – 28"
Available separated packaging				
Available in black finish				

*Static load rating is a non-moving weight test with the specified weight over 24 hours. Dynamic load rating is more robust and includes a moving weight test with a specific weight over a set number of cycles.

HR Series Comparison Ball Bearing Slides

Ball Bearing
Slides



301FU



303FU/303-100



303FUPT



303-50



307FU

Heavy Duty			Standard Duty	
301FU	303FU/ 303-100	303FUPT	303-50	307FU
Heavy Duty 100 lb. with Over Travel	Heavy Duty 100 lb.	Heavy Duty Push-To-Open	Standard Duty 100 lb.	Low Profile 75 lb.
100 lb. Dynamic	100 lb. Dynamic	100 lb. Dynamic	100 lb. Static	75 lb. Dynamic
1/2"				
45 mm	45 mm	45 mm	45 mm	36 mm
		Push-To-Open		
Both	Both	Both	Both	Both
10" – 28"	8" – 28"	12" – 22"	12" – 24"	10" – 22"
	✓		✓	
	✓			

EZ Open Heavy Duty Soft-close Slides 303-300 Series

A Dura-Close® EZ Open heavy duty soft-close slide designed to provide the most relaxed pull force and ease of opening of all Hardware Resources' ball bearing slides in either face frame or frameless applications.



Features

- 30% reduction in pull force compared to our 303FUSFT Series
- Full extension slide
- Grade 1 ANSI/BHMA certified
- 100 lb. Static weight rating
- Lubricated steel ball bearings with cage hold forward - retains cage during drawer member installation
- Non-handed trigger disconnect release

Specs

- 45 mm profile height
- 1/2" side spacing
- 1.0 mm x 1.0 mm x 1.2 mm cold rolled steel material
- Clear zinc electroplated finish
- 6.3 mm Euro screw or #8 x 7/16" truss head screw is recommended

Ordering

Description	Part Number
10" Zinc Slide	303-300-10
12" Zinc Slide	303-300-12
14" Zinc Slide	303-300-14
16" Zinc Slide	303-300-16
18" Zinc Slide	303-300-18
20" Zinc Slide	303-300-20
22" Zinc Slide	303-300-22
24" Zinc Slide	303-300-24
26" Zinc Slide	303-300-26
28" Zinc Slide	303-300-28

10 pr/ctn

Face Frame Front Mounting Bracket	
303FU4 100 pr/ctn	

Rear Mounting Bracket	
303FUSFT2 100 pr/ctn	

Self-Adjusting Plastic Rear Bracket	
303FUSFT3 100 pr/ctn	

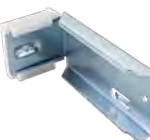
Rear Mounting Bracket with 8 mm Dowels	
303FUSFT5 100 pr/ctn	

Rear Mounting Bracket with 10 mm Dowels	
303FUSFT6 100 pr/ctn	

Static Load Rating



Travel



Profile



Finish



Side Spacing



Lengths

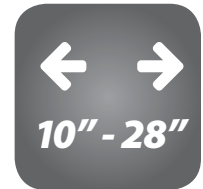

Hole Pattern



Material Dimensions



Packaging



Certification



EZ Open Heavy Duty Soft-close Slides 303-300 Series

Ball Bearing
Slides

Hole Pattern and Length Specifications

DRAWER MEMBER

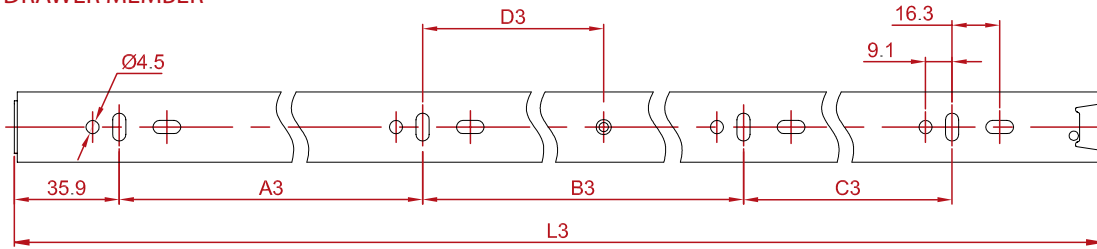

Specifications	L3	A3	B3	C3	D3
303-300-10 - 10"	245	160	-	-	-
303-300-12 - 12"	295	96	128	-	88
303-300-14 - 14"	345	128	128	-	75
303-300-16 - 16"	395	128	192	-	106
303-300-18 - 18"	445	160	192	-	94
303-300-20 - 20"	495	192	224	-	87
303-300-22 - 22"	545	224	224	-	85
303-300-24 - 24"	595	192	320	-	142
303-300-26 - 26"	645	192	224	160	167
303-300-28 - 28"	695	192	256	160	227

Installation Covers

		Protect slides from paint, stain and dust during installation
303COVER-C 100 pcs/ctn	Installation cover cabinet member	High strength plastic allows for multiple uses Installs on job site to protect slides from dust, paint, stain and damage Sold in 8' sticks - cut to fit any slide length Easily snaps on and off
303COVER-D 100 pcs/ctn	Installation cover drawer member	

CABINET MEMBER

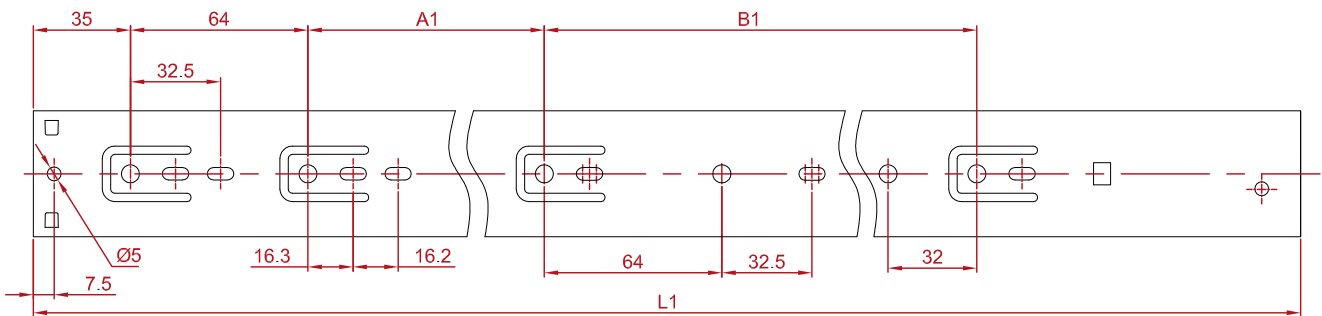

Specifications	L1	A1	B1
303-300-10 - 10"	250	-	-
303-300-12 - 12"	300	94	-
303-300-14 - 14"	350	128	-
303-300-16 - 16"	400	160	-
303-300-18 - 18"	450	224	-
303-300-20 - 20"	500	256	-
303-300-22 - 22"	550	288	-
303-300-24 - 24"	600	352	-
303-300-26 - 26"	650	206	224
303-300-28 - 28"	700	256	224

Slide Mounting Kit

	SLIDE-KIT 50 pks/ctn
Includes 4 L-brackets & attachment screws Perfect for rollout drawers - mount slides directly to cabinet floor or fixed shelf Threaded collars mean secure slide attachment using only a screwdriver and included screws	

Heavy Duty Soft-close Slides

303FUSFT Series

A heavy duty soft-close slide designed to be Hardware Resources' most robust soft-close ball bearing slide for almost any installation.



Features

- Full extension slide
- Grade 1 ANSI/BHMA certified
- 100 lb. dynamic weight rating
- Lubricated steel ball bearings with cage hold forward - retains cage during drawer member installation
- Non-handed trigger disconnect release

Dynamic Load Rating



Travel



Specs

- 45 mm profile height
- 1/2" side spacing
- 1.0 mm x 1.0 mm x 1.2 mm cold rolled steel material
- Clear zinc electroplated finish
- 6.3 mm Euro screw or #8 x 7/16" truss head screw is recommended

Profile



Finish



Ordering

Description	Part Number
12" Zinc Slide	303FUSFT12
14" Zinc Slide	303FUSFT14
16" Zinc Slide	303FUSFT16
18" Zinc Slide	303FUSFT18
20" Zinc Slide	303FUSFT20
22" Zinc Slide	303FUSFT22
24" Zinc Slide	303FUSFT24
26" Zinc Slide	303FUSFT26
28" Zinc Slide	303FUSFT28

15 pr/ctn

Face Frame Front Mounting Bracket



303FU4
100 pr/ctn

Rear Mounting Bracket

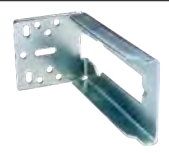

303FUSFT2
100 pr/ctn

Self-Adjusting Plastic Rear Bracket

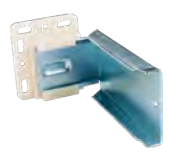

303FUSFT3
100 pr/ctn

Rear Mounting Bracket with 8 mm Dowels

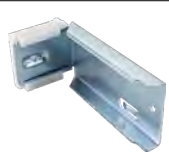

303FUSFT5
100 pr/ctn

Rear Mounting Bracket with 10 mm Dowels

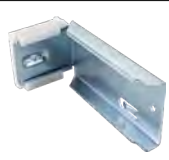

303FUSFT6
100 pr/ctn

Side Spacing



Lengths



Hole Pattern



Material Dimensions



Packaging



Certification



Heavy Duty Soft-close Slides 303FUSFT Series

Ball Bearing
Slides

Hole Pattern and Length Specifications

DRAWER MEMBER

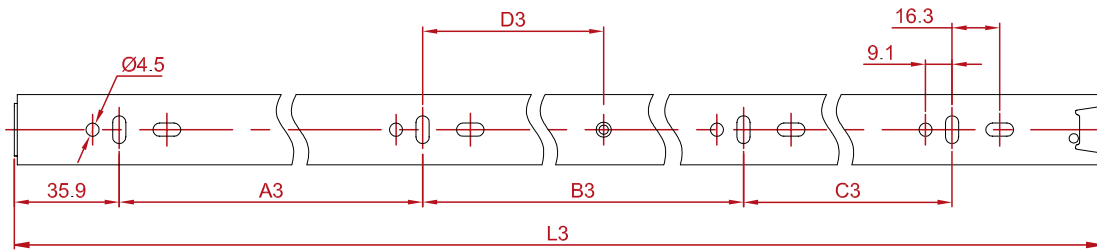

Specifications	L3	A3	B3	C3	D3
303FUSFT12 - 12"	295	96	128	-	88
303FUSFT14 - 14"	345	128	128	-	75
303FUSFT16 - 16"	395	128	192	-	106
303FUSFT18 - 18"	445	160	192	-	94
303FUSFT20 - 20"	495	192	224	-	87
303FUSFT22 - 22"	545	224	224	-	85
303FUSFT24 - 24"	595	192	320	-	142
303FUSFT26 - 26"	645	192	224	160	167
303FUSFT28 - 28"	695	192	256	160	227

Installation Covers

		Protect slides from paint, stain and dust during installation
303COVER-C 100 pcs/ctn	Installation cover cabinet member	High strength plastic allows for multiple uses Installs on job site to protect slides from dust, paint, stain and damage Sold in 8' sticks - cut to fit any slide length Easily snaps on and off
303COVER-D 100 pcs/ctn	Installation cover drawer member	

CABINET MEMBER

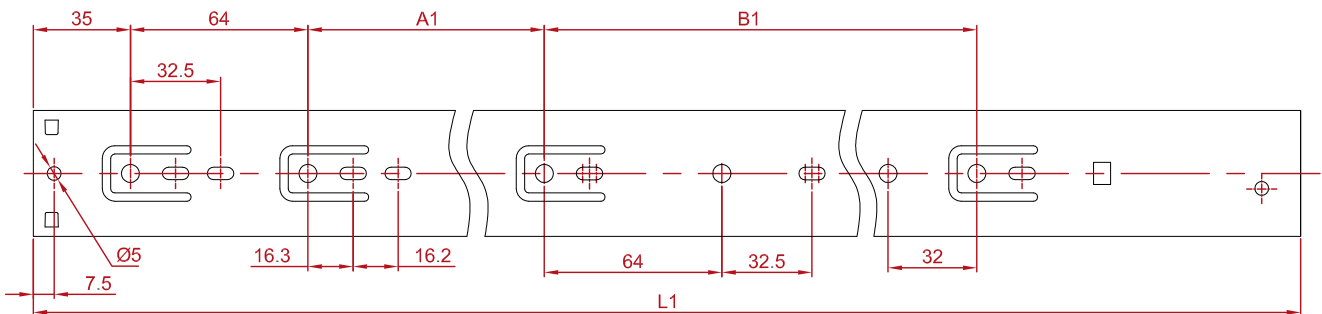

Specifications	L1	A1	B1
303FUSFT12 - 12"	300	94	-
303FUSFT14 - 14"	350	128	-
303FUSFT16 - 16"	400	160	-
303FUSFT18 - 18"	450	224	-
303FUSFT20 - 20"	500	256	-
303FUSFT22 - 22"	550	288	-
303FUSFT24 - 24"	600	352	-
303FUSFT26 - 26"	650	206	224
303FUSFT28 - 28"	700	256	224

Slide Mounting Kit

	SLIDE-KIT 50 pks/ctn
Includes 4 L-brackets & attachment screws Perfect for rollout drawers - mount slides directly to cabinet floor or fixed shelf Threaded collars mean secure slide attachment using only a screwdriver and included screws	

Commercial Grade Heavy Duty Slides

209FU Series - 1" Overtravel

A 225 lb. heavy duty commercial grade slide designed specifically for use in frameless applications.



Features

- 1" overtravel slide
- Grade 1 ANSI/BHMA certified
- 225 lb. dynamic weight rating
- Lubricated steel ball bearings
- Non-handed trigger disconnect release
- Synthetic rubber hold-in detent prevents bounce-back and roll out

Specs

- 54 mm profile height
- 3/4" side spacing
- 2.2 mm x 2.0 mm x 2.0 mm cold rolled steel material
- Clear zinc electroplated finish
- 6.3 mm Euro screw or #8 x 7/16" truss head screw is recommended

Ordering

Description	Part Number
16" Zinc Slide	209FU16
18" Zinc Slide	209FU18
20" Zinc Slide	209FU20
22" Zinc Slide	209FU22
24" Zinc Slide	209FU24
26" Zinc Slide	209FU26
28" Zinc Slide	209FU28
30" Zinc Slide	209FU30

6 pr/ctn

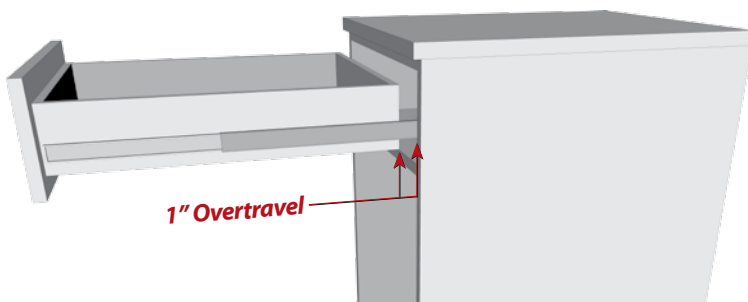

Dynamic Load Rating



Travel



Profile



Finish



Side Spacing



Lengths

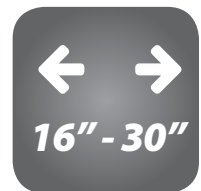

Hole Pattern



Material Dimensions



Packaging



Certification



Commercial Grade Heavy Duty Slides 209FU Series - 1" Overtravel

Hole Pattern and Length Specifications

DRAWER MEMBER

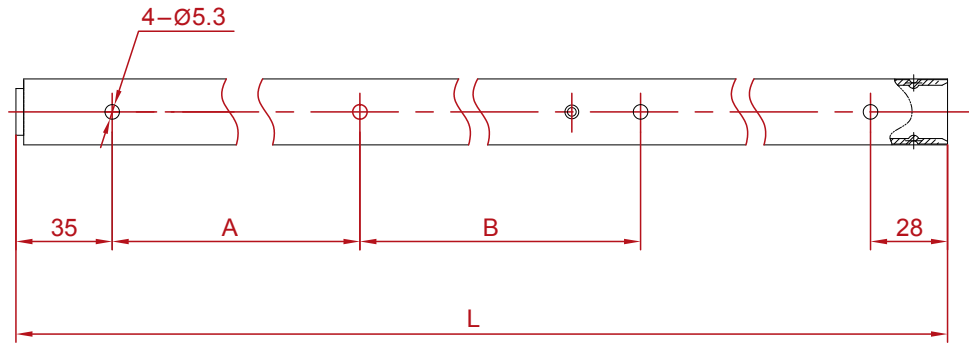

Specifications	L	A	B
209FU16 - 16"	404	96	128
209FU18 - 18"	455	96	224
209FU20 - 20"	506	96	224
209FU22 - 22"	557	96	288
209FU24 - 24"	608	160	292
209FU26 - 26"	659	160	292
209FU28 - 28"	710	160	356
209FU30 - 30"	761	160	356

CABINET MEMBER

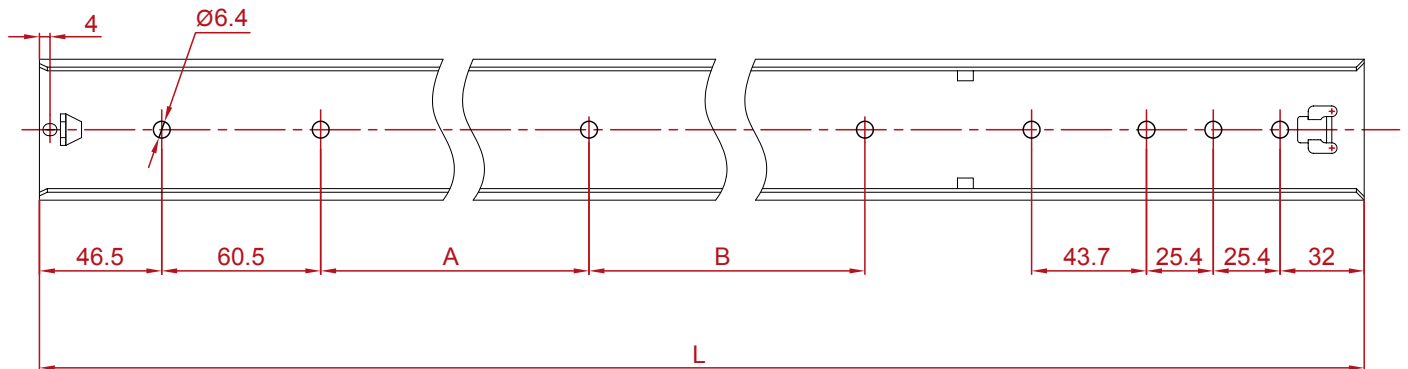

Specifications	L	A	B
209FU16 - 16"	406	-	-
209FU18 - 18"	457	128	-
209FU20 - 20"	508	128	-
209FU22 - 22"	559	128	96
209FU24 - 24"	610	160	128
209FU26 - 26"	661	160	128
209FU28 - 28"	712	160	160
209FU30 - 30"	763	160	160

Extra Heavy Duty Slides

300FU Series

A 150 lb. extra heavy duty grade slide perfect for file drawers, wide drawers or any drawer where weight is a concern.



Features

- Full extension slide
- Grade 1 ANSI/BHMA certified
- 150 lb. dynamic weight rating
- Lubricated steel ball bearings
- Non-handed trigger disconnect release
- Synthetic rubber hold-in detent prevents bounce-back and roll out

Specs

- 2" profile height
- 1/2" side spacing
- 1.5 mm x 1.5 mm x 1.5 mm cold rolled steel material
- Clear zinc electroplated finish
- 6.3 mm Euro screw or #8 x 7/16" truss head screw is recommended

Ordering

Description	Part Number
12" Zinc Slide	300FU12
14" Zinc Slide	300FU14
16" Zinc Slide	300FU16
18" Zinc Slide	300FU18
20" Zinc Slide	300FU20
22" Zinc Slide	300FU22
24" Zinc Slide	300FU24
26" Zinc Slide	300FU26
28" Zinc Slide	300FU28

10 pr/ctn

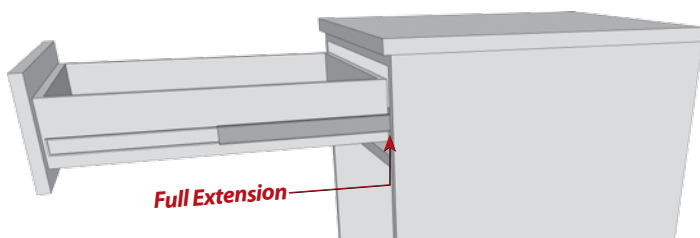

Dynamic Load Rating



Travel



Profile



Finish



Side Spacing



Lengths



Hole Pattern



Material Dimensions



Packaging



Certification



Extra Heavy Duty Slides 300FU Series

Ball Bearing
Slides

Hole Pattern and Length Specifications

DRAWER MEMBER

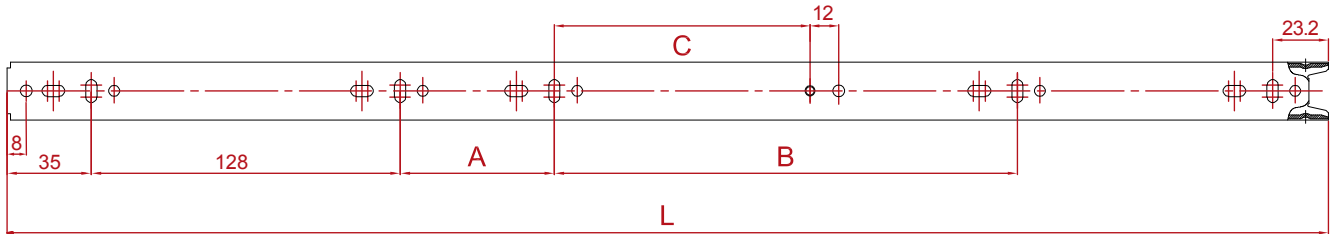

Specifications	L	A	B	C
300FU12 - 12"	298	-	-	60
300FU14 - 14"	348	-	-	98
300FU16 - 16"	398	-	-	124
300FU18 - 18"	448	192	-	146
300FU20 - 20"	498	64	160	106
300FU22 - 22"	548	64	192	106
300FU24 - 24"	598	64	224	156
300FU26 - 26"	648	64	256	168
300FU28 - 28"	698	64	288	193

CABINET MEMBER

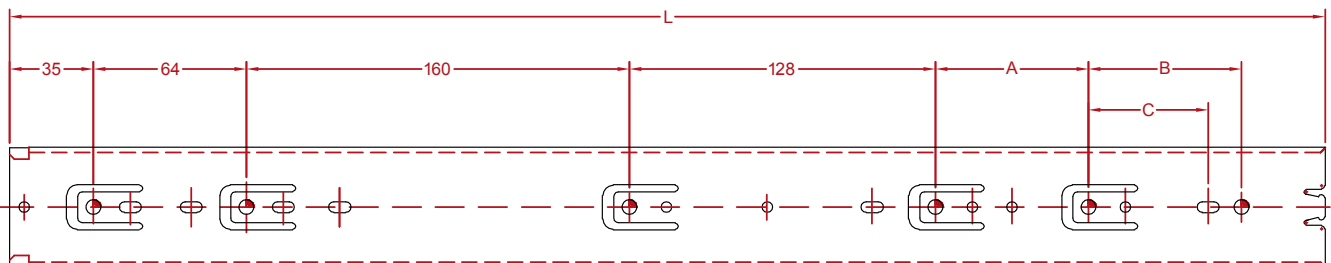

Specifications	L	A	B	C	D
300FU12 - 12"	300	136	-	-	-
300FU14 - 14"	350	160	-	-	-
300FU16 - 16"	400	160	64	-	-
300FU18 - 18"	450	160	128	-	-
300FU20 - 20"	500	160	128	-	64
300FU22 - 22"	550	160	128	-	64
300FU24 - 24"	600	160	128	64	64
300FU26 - 26"	650	160	128	96	64
300FU28 - 28"	700	160	128	96	128

Heavy Duty Slides

301FU Series - 1/2" Overtravel

A 100 lb. heavy duty slide with a slightly thicker gauge of steel and 1/2" overtravel makes this slide an excellent choice when you want the most rugged 100 lb. ball bearing slide.



Features

- 1/2" overtravel slide
- Grade 1 ANSI/BHMA certified
- 100 lb. dynamic weight rating
- Lubricated steel ball bearings with cage hold forward - retains cage during drawer member installation
- Non-handed trigger disconnect release
- Synthetic rubber hold-in detent prevents bounce-back and roll out

Dynamic Load Rating



Travel



Specs

- 45 mm profile height
- 1/2" side spacing
- 1.2 mm x 1.2 mm x 1.5 mm cold rolled steel material
- Clear zinc electroplated finish
- 6.3 mm Euro screw or #8 x 7/16" truss head screw is recommended

Profile



Finish



Ordering

Description	Part Number
10" Zinc Slide	301FU10
12" Zinc Slide	301FU12
14" Zinc Slide	301FU14
16" Zinc Slide	301FU16
18" Zinc Slide	301FU18
20" Zinc Slide	301FU20
22" Zinc Slide	301FU22
24" Zinc Slide	301FU24
26" Zinc Slide	301FU26
28" Zinc Slide	301FU28

15 pr/ctn

Rear Mounting Bracket with Plastic Clip	
301FU 100 pr/ctn	

Rear Mounting Bracket	
301FU2 100 pr/ctn	

Self-Adjusting Plastic Rear Bracket	
301FU3 100 pr/ctn	

Face Frame Front Mounting Bracket	
301FU4 100 pr/ctn	

Side Spacing



Lengths



Hole Pattern



Material Dimensions



Packaging



Certification



Heavy Duty Slides 301FU Series - 1/2" Overtravel

Ball Bearing
Slides

Hole Pattern and Length Specifications

DRAWER MEMBER

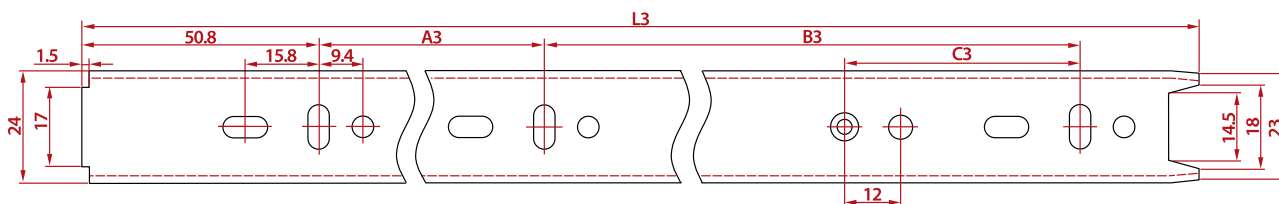

Specifications	L3	A3	B3	C3
301FU10 - 10"	250	-	175	38.5
301FU12 - 12"	303	77	147	50.5
301FU14 - 14"	354	96	160	57.8
301FU16 - 16"	404	128	192	96.6
301FU18 - 18"	455	141	211	103.6
301FU20 - 20"	506	173	243	141.8
301FU22 - 22"	557	205	275	179.6
301FU24 - 24"	608	224	288	186
301FU26 - 26"	658	236.5	339	250.4
301FU28 - 28"	709	255.5	320	248.6

Slide Mounting Kit

SLIDE-KIT
50 pks/ctn

Includes 4 L-brackets & attachment screws
Perfect for rollout drawers - mount slides directly to cabinet floor or fixed shelf
Threaded collars mean secure slide attachment using only a screwdriver and included screws

CABINET MEMBER

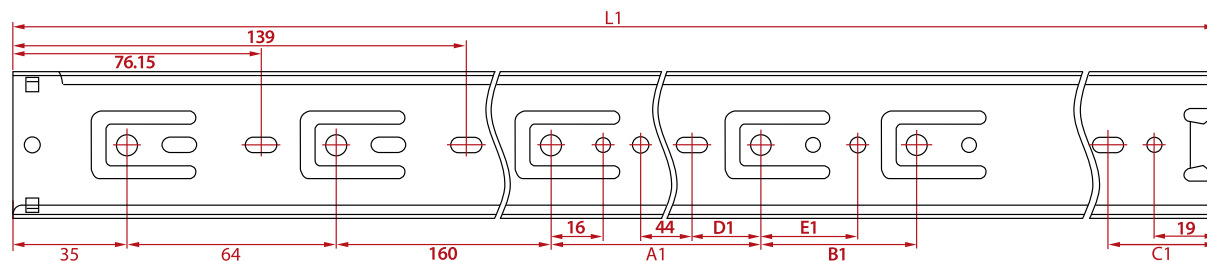

Specifications	L1	A1	B1	C1	D1	E1
301FU10 - 10"	254	-	-	-	-	-
301FU12 - 12"	304.8	-	-	-	-	-
301FU14 - 14"	355.6	-	-	47.3	-	-
301FU16 - 16"	406.4	64	-	38.5	-	-
301FU18 - 18"	457.2	128	-	-	25.45	32.15
301FU20 - 20"	508	128	64	-	25.45	32.15
301FU22 - 22"	558.8	128	64	57.8	25.45	32.15
301FU24 - 24"	609.6	128	128	44.6	25.45	32.15
301FU26 - 26"	660.4	128	192	31.4	25.45	32.15
301FU28 - 28"	711.2	128	192	82.2	25.45	32.15

Heavy Duty Slides 303FU Series

Hardware Resources' best selling slide series has been the go-to 100 lb. ball bearing slide for cabinet makers for over a decade. This dependable, worry-free slide is a great solution to almost any application.



Features

- Full extension slide
- Grade 1 ANSI/BHMA certified
- 100 lb. dynamic weight rating
- Lubricated steel ball bearings with cage hold forward - retains cage during drawer member installation
- Non-handed trigger disconnect release
- Synthetic rubber hold-in detent prevents bounce-back and roll out

Specs

- 45 mm profile height
- 1/2" side spacing
- 1.0 mm x 1.0 mm x 1.2 mm cold rolled steel material
- Clear zinc electroplated or black finish
- 6.3 mm Euro screw or #8 x 7/16" truss head screw is recommended

Dynamic Load Rating



Travel



Profile



Finish



Side Spacing



Lengths



Hole Pattern



Material Dimensions



Packaging



Certification



ASSEMBLED (sold per pair)

Length	Zinc	Black
8" Slide	303FU8	
10" Slide	303FU10	303FU10BLK
12" Slide	303FU12	303FU12BLK
14" Slide	303FU14	303FU14BLK
16" Slide	303FU16	303FU16BLK
18" Slide	303FU18	303FU18BLK
20" Slide	303FU20	303FU20BLK
22" Slide	303FU22	303FU22BLK
24" Slide	303FU24	
26" Slide	303FU26	
28" Slide	303FU28	

15 pr/ctn 15 pr/ctn

SPLIT SLIDES (sold as each)

Length		Zinc	Black
12" Slide	cabinet drawer	303-100-12C 303-100-12D	303-150-12C 303-150-12D
14" Slide	cabinet drawer	303-100-14C 303-100-14D	303-150-14C 303-150-14D
16" Slide	cabinet drawer	303-100-16C 303-100-16D	303-150-16C 303-150-16D
18" Slide	cabinet drawer	303-100-18C 303-100-18D	303-150-18C 303-150-18D
20" Slide	cabinet drawer	303-100-20C 303-100-20D	303-150-20C 303-150-20D
22" Slide	cabinet drawer	303-100-22C 303-100-22D	303-150-22C 303-150-22D
24" Slide	cabinet drawer	303-100-24C 303-100-24D	
26" Slide	cabinet drawer	303-100-26C 303-100-26D	

30 cabinet/ctn
60 drawer/ctn

Rear Mounting Bracket	
303FU2	
100 pr/ctn	
Self-Adjusting Plastic Rear Bracket	
303FU3	
100 pr/ctn	

Rear Mounting Bracket with 8 mm Dowels	
303FU5	
100 pr/ctn	
Rear Mounting Bracket with 10 mm Dowels	
303FU6	
100 pr/ctn	

Face Frame Front Mounting Bracket	
303FU4	
100 pr/ctn	

Heavy Duty Slides 303FU Series

Ball Bearing
Slides

Hole Pattern and Length Specifications

DRAWER MEMBER

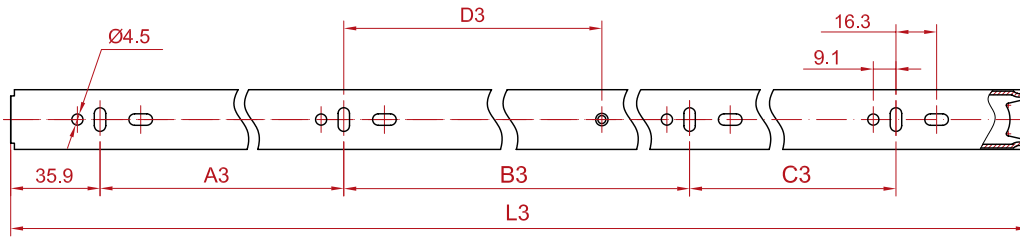

Specifications	L3	A3	B3	C3	D3
303FU8 - 8"	197	128	-	-	-
303FU10 - 10"	247	169	-	-	-
303FU12 - 12"	297	96	128	-	90
303FU14 - 14"	347	128	128	-	85
303FU16 - 16"	397	128	192	-	110.5
303FU18 - 18"	447	160	192	-	101
303FU20 - 20"	497	192	224	-	95
303FU22 - 22"	547	224	224	-	81
303FU24 - 24"	597	192	320	-	140
303FU26 - 26"	647	192	224	160	167
303FU28 - 28"	697	192	256	160	227

Installation Covers

		Protect slides from paint, stain and dust during installation
303COVER-C 100 pcs/ctn	Installation cover cabinet member	High strength plastic allows for multiple uses Installs on job site to protect slides from dust, paint, stain and damage Sold in 8' sticks - cut to fit any slide length Easily snaps on and off
303COVER-D 100 pcs/ctn	Installation cover drawer member	

CABINET MEMBER

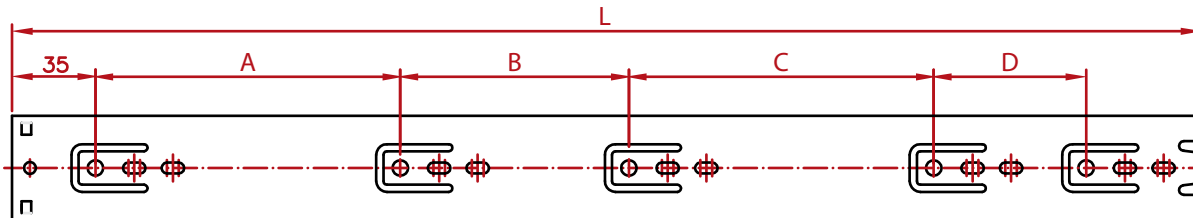

Specifications	L	A	B	C	D
303FU8 - 8"	200	64	76	-	-
303FU10 - 10"	250	64	76	-	-
303FU12 - 12"	300	128	96	-	-
303FU14 - 14"	350	128	96	-	-
303FU16 - 16"	400	128	96	64	-
303FU18 - 18"	450	128	96	128	-
303FU20 - 20"	500	128	96	128	64
303FU22 - 22"	550	128	96	128	64
303FU24 - 24"	600	128	96	192	64
303FU26 - 26"	650	128	164	192	64
303FU28 - 28"	700	128	192	224	64

Slide Mounting Kit

	SLIDE-KIT 50 pks/ctn
Includes 4 L-brackets & attachment screws Perfect for rollout drawers - mount slides directly to cabinet floor or fixed shelf Threaded collars mean secure slide attachment using only a screwdriver and included screws	

100 lb. Standard Duty Slides

303-50 Series

Newly introduced in response to demand for the most economical 100 lb. ball bearing slide is Hardware Resources' 303-50 Series. These slides, while an economical option, still provide quality performance, ease of installation and ANSI-certified worry-free operation.



Features

- Full extension slide
- Grade 1 ANSI/BHMA certified
- 100 lb. static weight rating
- Lubricated steel ball bearings with cage hold forward - retains cage during drawer member installation
- Non-handed trigger disconnect release
- Synthetic rubber hold-in detent prevents bounce-back and roll out

Specs

- 45 mm profile height
- Clear zinc electroplated finish
- 1/2" side spacing
- 6.3 mm Euro screw or #8 x 7/16" truss head screw is recommended
- 0.9 mm x 0.9 mm x 1.2 mm cold rolled steel material

Static Load Rating



Travel



Profile





Finish



ASSEMBLED (sold per pair)

Length	Zinc
12" Slide	303-50-12
14" Slide	303-50-14
16" Slide	303-50-16
18" Slide	303-50-18
20" Slide	303-50-20
22" Slide	303-50-22
24" Slide	303-50-24

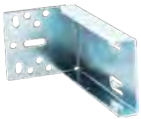

15 pr/ctn

Rear Mounting Bracket	
303FU2	
100 pr/ctn	
Self-Adjusting Plastic Rear Bracket	
303FU3	
100 pr/ctn	
Rear Mounting Bracket with 8 mm Dowels	
303FU5	
100 pr/ctn	

SPLIT SLIDES (sold as each)

Length	Zinc
12" Slide	cabinet 303-50-12C drawer 303-50-12D
14" Slide	cabinet 303-50-14C drawer 303-50-14D
16" Slide	cabinet 303-50-16C drawer 303-50-16D
18" Slide	cabinet 303-50-18C drawer 303-50-18D
20" Slide	cabinet 303-50-20C drawer 303-50-20D
22" Slide	cabinet 303-50-22C drawer 303-50-22D
24" Slide	cabinet 303-50-24C drawer 303-50-24D

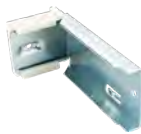
30 cabinet/ctn
60 drawer/ctn

Rear Mounting Bracket with 10 mm Dowels	
303FU6	
100 pr/ctn	
Face Frame Front Mounting Bracket	
303FU4	
100 pr/ctn	

Side Spacing



Lengths



Hole Pattern



Material Dimensions



Packaging



Certification



100 lb. Standard Duty Slides 303-50 Series

Ball Bearing
Slides

Hole Pattern and Length Specifications

DRAWER MEMBER

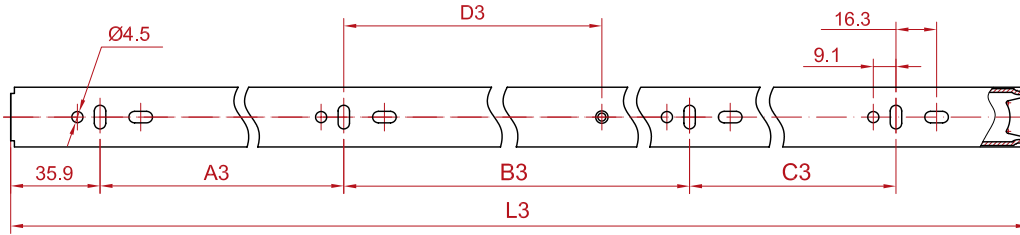

Specifications	L3	A3	B3	C3	D3
303-50-12 - 12"	297	96	128	-	90
303-50-14 - 14"	347	128	128	-	85
303-50-16 - 16"	397	128	192	-	110.5
303-50-18 - 18"	447	160	192	-	101
303-50-20 - 20"	497	192	224	-	95
303-50-22 - 22"	547	224	224	-	81
303-50-24 - 24"	597	192	320	-	140

Installation Covers

		Protect slides from paint, stain and dust during installation
303COVER-C 100 pcs/ctn	Installation cover cabinet member	High strength plastic allows for multiple uses Installs on job site to protect slides from dust, paint, stain and damage Sold in 8' sticks - cut to fit any slide length Easily snaps on and off
303COVER-D 100 pcs/ctn	Installation cover drawer member	

CABINET MEMBER

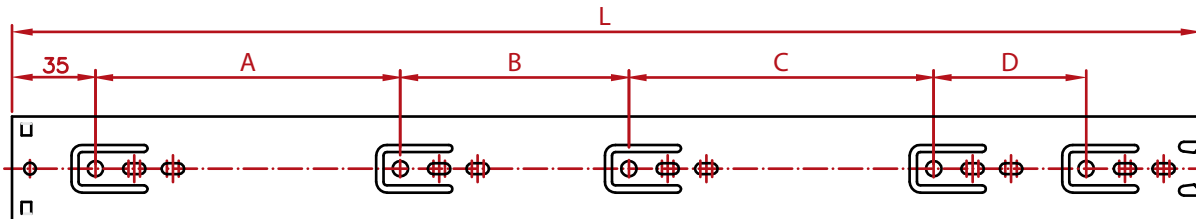

Specifications	L	A	B	C	D
303-50-12 - 12"	300	128	96	-	-
303-50-14 - 14"	350	128	96	-	-
303-50-16 - 16"	400	128	96	64	-
303-50-18 - 18"	450	128	96	128	-
303-50-20 - 20"	500	128	96	128	64
303-50-22 - 22"	550	128	96	128	64
303-50-24 - 24"	600	128	96	192	64

Slide Mounting Kit

	SLIDE-KIT 50 pks/ctn
Includes 4 L-brackets & attachment screws Perfect for rollout drawers - mount slides directly to cabinet floor or fixed shelf Threaded collars mean secure slide attachment using only a screwdriver and included screws	

Push-to-Open Slides

303FUPT Series

A heavy duty 100 lb. push-to-open ball bearing slide designed for use in either frameless or face frame applications. Very popular for use in a cutlery drawer insert or when a clean, no-hardware look is required on doors and drawer fronts.



Features

- Full extension slide
- Grade 1 ANSI/BHMA certified
- 100 lb. dynamic weight rating
- Lubricated steel ball bearings with cage hold forward - retains cage during drawer member installation
- Non-handed trigger disconnect release

Specs

- 45 mm profile height
- 1/2" side spacing
- 1.0 mm x 1.0 mm x 1.2 mm cold rolled steel material
- Clear zinc electroplated finish
- 6.3 mm Euro screw or #8 x 7/16" truss head screw is recommended

Ordering

Description	Part Number
12" Zinc Slide	303FUPT12
14" Zinc Slide	303FUPT14
16" Zinc Slide	303FUPT16
18" Zinc Slide	303FUPT18
20" Zinc Slide	303FUPT20
22" Zinc Slide	303FUPT22

15 pr/ctn

Rear Mounting Bracket	
303FUSFT2 100 pr/ctn	
Self-Adjusting Plastic Rear Bracket	
303FUSFT3 100 pr/ctn	
Rear Mounting Bracket with 8 mm Dowels	
303FUSFT5 100 pr/ctn	
Rear Mounting Bracket with 10 mm Dowels	
303FUSFT6 100 pr/ctn	
Face Frame Front Mounting Bracket	
303FU4 100 pr/ctn	

For Inset application, no special installation required

For Overlay application, allow 1/8" clearance for push-to-open mechanism

Opens drawer approximately 2" from closed position

Great for clean-line drawers without hardware and for commercial cabinetry

Dynamic Load Rating



Travel



Profile



Finish



Side Spacing



Lengths



Hole Pattern



Material Dimensions



Packaging



Certification



Push-to-Open Slides 303FUPT Series

Ball Bearing
Slides

Hole Pattern and Length Specifications

DRAWER MEMBER

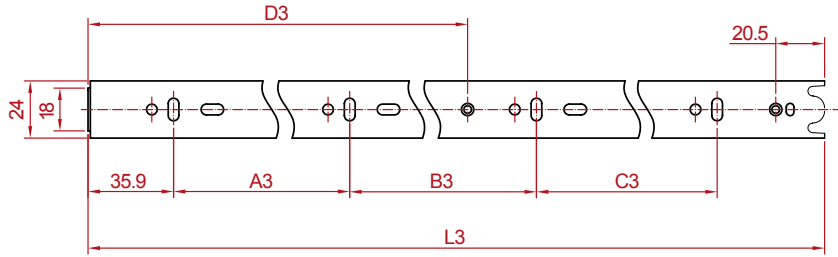

Specifications	L3	A3	B3	C3	D3
303FUPT12 - 12"	288	96	128	-	220
303FUPT14 - 14"	338	128	128	-	255
303FUPT16 - 16"	388	128	192	-	290
303FUPT18 - 18"	438	160	192	-	320
303FUPT20 - 20"	488	192	224	-	340
303FUPT22 - 22"	538	224	224	-	365

Installation Covers

		Protect slides from paint, stain and dust during installation
303COVER-C 100 pcs/ctn	Installation cover cabinet member	High strength plastic allows for multiple uses Installs on job site to protect slides from dust, paint, stain and damage Sold in 8' sticks - cut to fit any slide length Easily snaps on and off
303COVER-D 100 pcs/ctn	Installation cover drawer member	

CABINET MEMBER

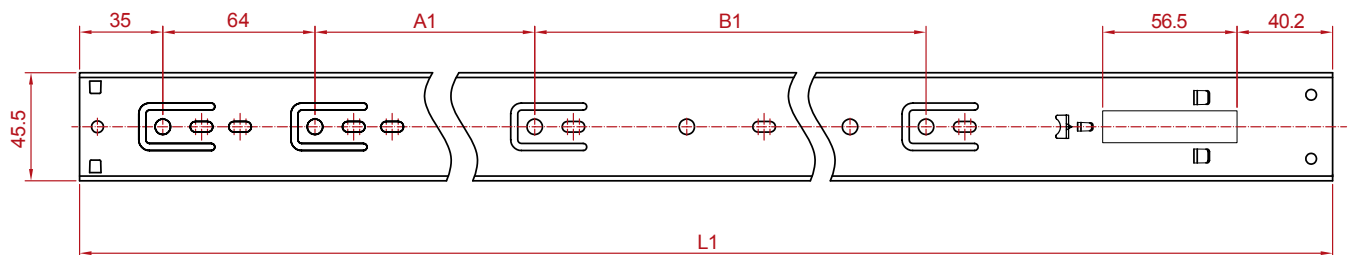

Specifications	L1	A1	B1
303FUPT12 - 12"	300	64	-
303FUPT14 - 14"	350	96	-
303FUPT16 - 16"	400	128	-
303FUPT18 - 18"	450	160	-
303FUPT20 - 20"	500	256	-
303FUPT22 - 22"	550	288	-

Slide Mounting Kit

	SLIDE-KIT 50 pks/ctn
Includes 4 L-brackets & attachment screws Perfect for rollout drawers - mount slides directly to cabinet floor or fixed shelf Threaded collars mean secure slide attachment using only a screwdriver and included screws	

Medium Duty Slides - 36 mm

307FU Series

A low profile 75 lb. slide perfect for furniture such as end tables, nightstands or many other small drawer applications.



Features

- Full extension slide
- Grade 1 ANSI/BHMA certified
- 75 lb. dynamic weight rating
- Lubricated steel ball bearings with cage hold forward - retains cage during drawer member installation
- Non-handed trigger disconnect release
- Synthetic rubber hold-in detent prevents bounce-back and roll out

Dynamic Load Rating



Travel



Profile



Finish





Specs

- 36 mm profile height
- 1/2" side spacing
- 1.2 mm x 1.0 mm x 1.2 mm cold rolled steel material
- Clear zinc electroplated finish
- 6.3 mm Euro screw or #8 x 7/16" truss head screw is recommended

Ordering

Description	Part Number
10" Zinc Slide	307FU10
12" Zinc Slide	307FU12
14" Zinc Slide	307FU14
16" Zinc Slide	307FU16
18" Zinc Slide	307FU18
20" Zinc Slide	307FU20
22" Zinc Slide	307FU22

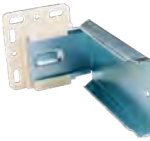
15 pr/ctn

Rear Mounting Bracket	
307FU2 100 pr/ctn	
Self-Adjusting Plastic Rear Bracket	
307FU3 100 pr/ctn	
Face Frame Front Mounting Bracket	
307FU4 100 pr/ctn	

Side Spacing



Lengths



Hole Pattern



Material Dimensions



Packaging



Certification

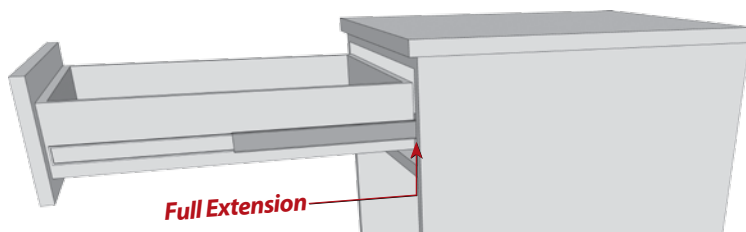

Medium Duty Slides - 36 mm 307FU Series

Ball Bearing
Slides

Hole Pattern and Length Specifications

DRAWER MEMBER

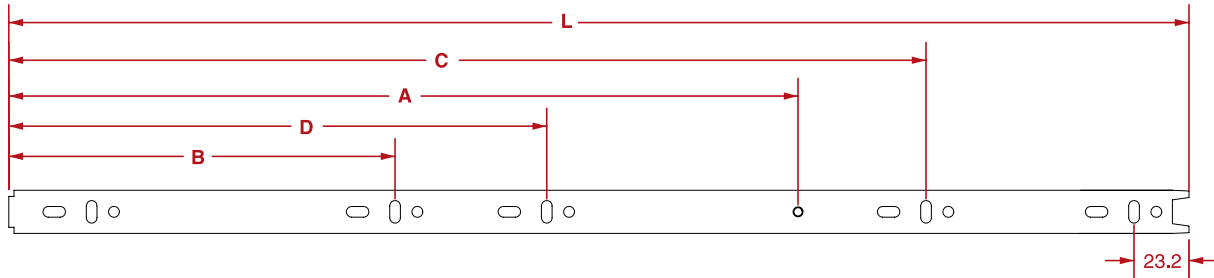

Specifications	L	A	B	C	D
307FU10 - 10"	248	179	99	-	-
307FU12 - 12"	298	223	163	-	-
307FU14 - 14"	348	261	163	-	-
307FU16 - 16"	398	287	163	-	-
307FU18 - 18"	448	309	163	355	-
307FU20 - 20"	498	333	163	387	227
307FU22 - 22"	548	333	163	419	227

CABINET MEMBER

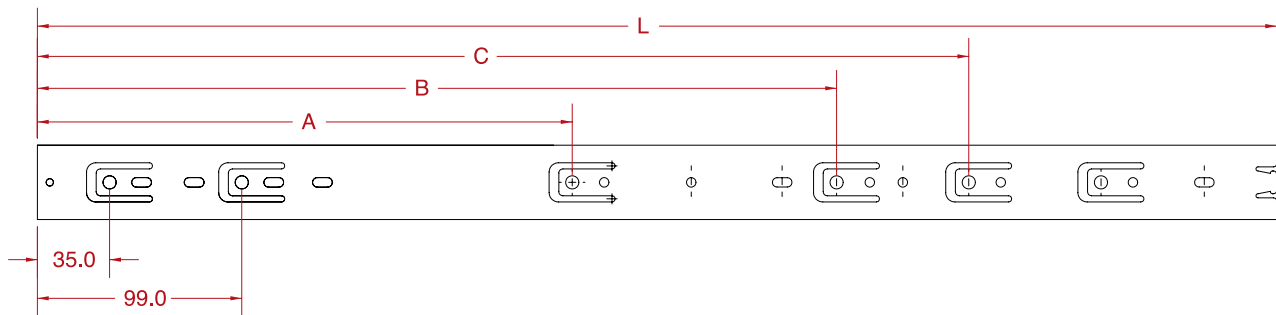

Specifications	L	A	B	C
307FU10 - 10"	240	185	-	-
307FU12 - 12"	300	259	-	-
307FU14 - 14"	350	259	-	-
307FU16 - 16"	400	259	323	-
307FU18 - 18"	450	259	387	-
307FU20 - 20"	500	259	387	451
307FU22 - 22"	550	259	387	451

Keyboard Slide without Tray

14" Black Slide	70541BK 20 pr/ctn
<i>Recommended screw:</i> #6 pan head	



- » Variable height range of 2" – 3-7/8" in 7/16" increments
- » Heavy duty cold rolled steel construction with black powder coat finish
- » Keyboard slide built onto a 14" ball bearing slide with 11-1/4" tray extension
- » #8 x 3/4" pan washer head screw recommended for installation

Keyboard Slide with Tray

14" Zinc Slide with Light Grey Tray	2055 10 pr/ctn
<i>Recommended screw:</i> #6 pan head	



- » Variable height range of 2-3/16" – 3-1/2" in 7/16" increments
- » Heavy duty cold rolled steel construction with clear zinc finish
- » Light grey keyboard tray preassembled featuring a pen holder tray with lid
- » Tray is 22" wide x 10" deep
- » Keyboard slide built onto a 14" ball bearing slide with 10" tray extension
- » #8 x 3/4" pan washer head screw recommended for installation

Slide Mounting Kits

4 Zinc L-brackets & Screws	SLIDE-KIT 50 pks/ctn
<i>Recommended screw:</i> #6 pan head	



- » Perfect for rollout drawers - mount slides directly to cabinet floor or fixed shelf
- » Will fit 301FU series and 303FU series ball bearing slides as well as undermount slides
- » Threaded collars mean secure attachment using only a screwdriver
- » Screws for mounting to slides included
- » #6 pan head screw suggested for installation to cabinet floor

Quick Tray System



- » System only requires four simple components
- » Overall height is 20-1/8"
- » Vertical adjustment of shelves in increments of 1-1/4"
- » No tools necessary for shelf adjustments
- » Front spacing lip allows for offset behind the face frame
- » Supports are non-handed for easy installation
- » Frameless application can be mounted with wood or euro screws
- » Face frame application can be fastened with staples or wood screws
- » Can be factory installed or added to existing cabinets

Use with any slide:

UNDERMOUNT



BALL BEARING

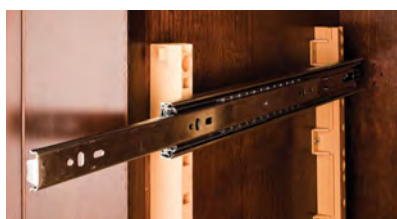

EPOXY

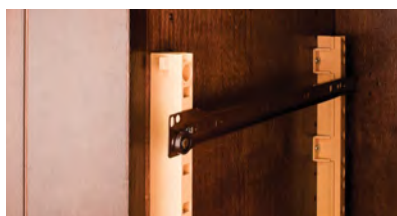

Pilasters:			
Maple	B512-01 5 pcs/ctn	1-1/4" Pilaster System Pack, clear-coated maple wood pilaster, plastic insert Pack Includes: 4 pilasters, 8 hook dowels and 16 screws	
White	B500-00 100 pcs/ctn	Quick Tray 1" Pilaster bulk pack Pack Includes: 100 pilasters, 200 hook dowels and 200 screws	
	B520-00 20 pks/ctn	1" Pilaster System Pack Pack Includes: 4 pilasters, 8 hook dowels and 8 screws	
	B521-00 20 pks/ctn	1-1/4" Pilaster System Pack Pack Includes: 4 pilasters, 8 hook dowels and 8 screws	
Beige	B520-01 20 pks/ctn	1" Pilaster System Pack Pack Includes: 4 pilasters, 8 hook dowels and 8 screws	
	B521-01 20 pks/ctn	1-1/4" Pilaster System Pack Pack Includes: 4 pilasters, 8 hook dowels and 8 screws	
Cream	T-501-02 100 pcs/ctn	1-1/4" Support Pilaster with 0.25" Standoff	
	T-502-02 100 pcs/ctn	1-1/4" Support Pilaster with 0.325" Standoff	
Accessories:			
White	530117 2000 pcs/ctn	7/8" Plastic Spacer with 1-3/8" CC holes 1-7/8" overall width	
	EXE001 2000 pcs/ctn	3/4" Spacer with 32 mm holes	
Beige	B-400-02 100 pcs/pk 10 pks/ctn	Drawer Bumper for Rollout Tray 11/16" (18 mm) *Recommended screw: 6X7160-B	
Zinc	T-506 1000 pcs/ctn	Hook Dowels for ball bearing slides (sold individually)	
	T-508 1000 pcs/ctn	Hook Dowels for undermount slides (sold individually)	
	T-501 1000 pcs/ctn	Dowel Screw for Hook Dowel (sold individually)	
	B-310 50 pks/ctn	Hook Dowel & Screw Pack for ball bearing slides Includes 4 hook dowels & 4 screws	

Economy Self-closing Slides 2000 Series

An economy self-closing slide designed specifically for use in either frameless or face frame applications.



Features

- 3/4" extension slide travel
- 75 lb. load rating
- Side or bottom mounting style for frameless and face frame cabinetry
- POM synthetic plastic roller, cylindrically ground for smooth and quiet action
- Positive lock-out on both members
- Disconnects via lift out
- Self-closing with positive stop prevents drawer bounce-back and roll out

Specs

- 1-7/16" profile height
- 1/2" side spacing
- 1.0 mm hot rolled steel material
- Epoxy powdercoated cream white finish
- 32 mm system hole pattern
- 6.3 mm euro screw or #6 undercut screw is recommended

Ordering

Cream White

Description	Part Number
12" Bulk Pack Cabinet Member	2030CL/CR
12" Bulk Pack Drawer Member	2030DL/DR
14" Bulk Pack Cabinet Member	2035CL/CR
14" Bulk Pack Drawer Member	2035DL/DR
16" Bulk Pack Cabinet Member	2040CL/CR
16" Bulk Pack Drawer Member	2040DL/DR
18" Bulk Pack Cabinet Member	2045CL/CR
18" Bulk Pack Drawer Member	2045DL/DR
20" Bulk Pack Cabinet Member	2050CL/CR
20" Bulk Pack Drawer Member	2050DL/DR
22" Bulk Pack Cabinet Member	2055CL/CR
22" Bulk Pack Drawer Member	2055DL/DR

100 pcs/ctn

Cream White

Description	Part Number
12" (300 mm) Builder Pack	2030
14" (350 mm) Builder Pack	2035
16" (400 mm) Builder Pack	2040
18" (450 mm) Builder Pack	2045
20" (500 mm) Builder Pack	2050
22" (550 mm) Builder Pack	2055B

25 pcs/ctn

Rear Mounting Bracket

Left Hand Rear Socket	9000-LH	
Right Hand Rear Socket	9000-RH	

Mounts to rear cabinet wall - slotted holes allow vertical and horizontal adjustment

100 pcs/bag - 500 pcs/ctn

Economy Self-closing Slides 2000 Series

Epoxy
Slides

Hole Pattern and Length Specifications

DRAWER MEMBER

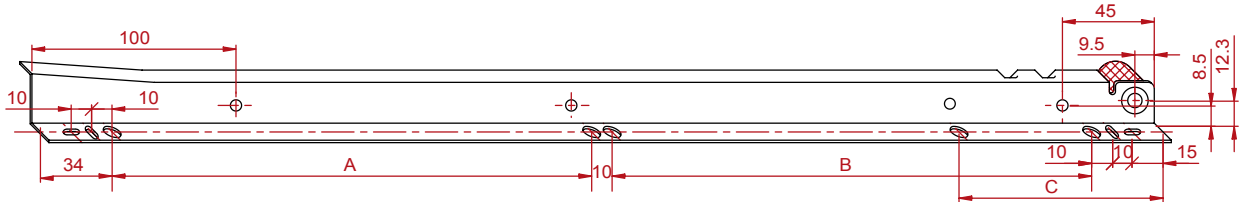

Specifications	L	A	B	C
2030 - 12"	300	110	110	-
2035 - 14"	350	135	135	-
2040 - 16"	400	160	160	-
2045 - 18"	450	185	185	-
2050 - 20"	500	210	210	53
2055 - 22"	550	235	235	102

CABINET MEMBER

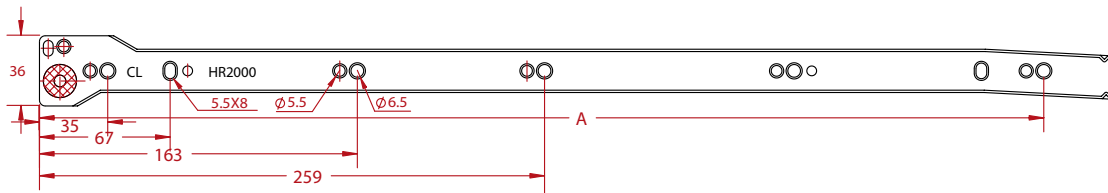

Specifications	A
2030 - 12"	-
2035 - 14"	323
2040 - 16"	355
2045 - 18"	387
2050 - 20"	451
2055 - 22"	515

Self-closing Slides 5000 Series

A standard duty self-closing slide designed for use in either frameless or face frame applications.



Features

- 3/4" extension slide travel
- 75 lb. load rating
- Side or bottom mounting style for frameless and face frame cabinetry
- POM synthetic plastic roller, cylindrically ground for smooth and quiet action
- Positive lock-out on both members
- Disconnects via lift out
- Self-closing with positive stop prevents drawer bounce-back and roll out

Specs

- 1-7/16" profile height
- 1/2" side spacing
- 1.0 mm hot rolled steel material
- Epoxy powdercoated cream white finish
- 32 mm system hole pattern
- 6.3 mm euro screw or #6 undercut screw is recommended

Ordering

Cream White

Description	Part Number
12" Bulk Pack Cabinet Member	5030CL/CR
12" Bulk Pack Drawer Member	5030DL/DR
14" Bulk Pack Cabinet Member	5035CL/CR
14" Bulk Pack Drawer Member	5035DL/DR
16" Bulk Pack Cabinet Member	5040CL/CR
16" Bulk Pack Drawer Member	5040DL/DR
18" Bulk Pack Cabinet Member	5045CL/CR
18" Bulk Pack Drawer Member	5045DL/DR
20" Bulk Pack Cabinet Member	5050CL/CR
20" Bulk Pack Drawer Member	5050DL/DR
22" Bulk Pack Cabinet Member	5055CL/CR
22" Bulk Pack Drawer Member	5055DL/DR
24" Bulk Pack Cabinet Member	5060CL/CR
24" Bulk Pack Drawer Member	5060DL/DR

100 pcs/ctn

Cream White

Description	Part Number
14" (350 mm) Builder Pack	5035
16" (400 mm) Builder Pack	5040
18" (450 mm) Builder Pack	5045
20" (500 mm) Builder Pack	5050
22" (550 mm) Builder Pack	5055

25 pcs/ctn

Brown

Description	Part Number
14" Bulk Pack Cabinet Member	5514CL/CR
14" Bulk Pack Drawer Member	5514DL/DR
16" Bulk Pack Cabinet Member	5516CL/CR
16" Bulk Pack Drawer Member	5516DL/DR
18" Bulk Pack Cabinet Member	5518CL/CR
18" Bulk Pack Drawer Member	5518DL/DR

100 pcs/ctn

Premium Self-closing Slides 9600 Series

A premium self-closing slide designed perfect for an upgraded epoxy slide experience.



Features

- 3/4" extension slide travel
- 100 lb. load rating
- Side or bottom mounting style for frameless and face frame cabinetry
- POM synthetic plastic roller, cylindrically ground for smooth and quiet action
- Captive right channel reduces side play
- Positive lock-out on both members
- Disconnects via lift out
- Self-closing with positive stop prevents drawer bounce-back and roll out

Specs

- 1-7/16" profile height
- 1/2" side spacing
- 1.3 mm hot rolled steel material
- Epoxy powdercoated cream white finish
- 32 mm system hole pattern
- 6.3 mm euro screw or #6 undercut screw is recommended

Cream White

Description	Part Number
18" (450 mm) Builder Pack	9645
20" (500 mm) Builder Pack	9650
22" (550 mm) Builder Pack	9655

25 pcs/ctn

Mounting Brackets



Left Hand Rear Socket	9600-LH
Right Hand Rear Socket	9600-RH
Mounts to rear cabinet wall - slotted holes allow vertical and horizontal adjustment	

100 pcs/bag - 500 pcs/ctn

DRAWER MEMBER

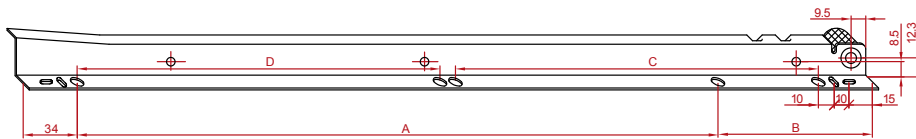

Hole Pattern and Length Specifications

Specifications	A	B	C	D
9645 - 18"	-	-	185	185
9650 - 20"	413	53	210	210
9655 - 22"	413	102	235	235

CABINET MEMBER

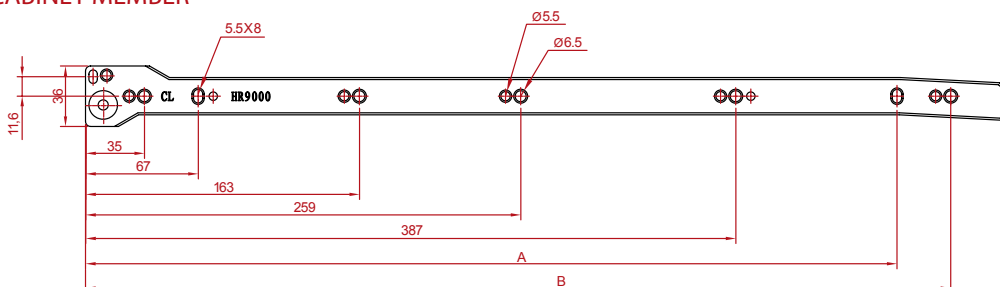

Specifications	A	B
9645 - 18"	355	387
9650 - 20"	419	451
9655 - 22"	483	515

Self-closing Double Captive Slides 9400/9500 Series

Epoxy
Slides

A self-closing double captive slide that reduces slide play for a more stable drawer action.



Features

- 3/4" extension slide travel
- 100 lb. load rating
- Side or bottom mounting style for frameless and face frame cabinetry
- POM synthetic plastic roller, cylindrically ground for smooth and quiet action
- Double captive (left and right channels) reduces side play for on-track precision across the entire length of the slide
- Positive lock-out on both members
- Disconnects via lift out
- Self-closing with positive stop prevents drawer bounce-back and roll out

Specs

- 1-5/8" profile height
- 1/2" side spacing
- 1.0 mm cold rolled steel material
- Epoxy powdercoated cream white finish
- 32 mm system hole pattern
- 6.3 mm euro screw or #6 undercut screw is recommended

Cream White

Description	Part Number
16-3/8" (416 mm) Bulk Pack Cabinet Member	9416CL/CR
15-3/4" (400 mm) Bulk Pack Drawer Member	9400DL/DR
18-3/4" (476 mm) Bulk Pack Cabinet Member	9476CL/CR
17-3/4" (450 mm) Bulk Pack Drawer Member	9450DL/DR
19-3/4" (500 mm) Bulk Pack Cabinet Member	9500CL/CR
19-3/4" (500 mm) Bulk Pack Drawer Member	9500DL/DR
22-1/2" (572 mm) Bulk Pack Cabinet Member	9572CL/CR
21-5/8" (550 mm) Bulk Pack Drawer Member	9550DL/DR

100 pcs/ctn

Mounting Brackets

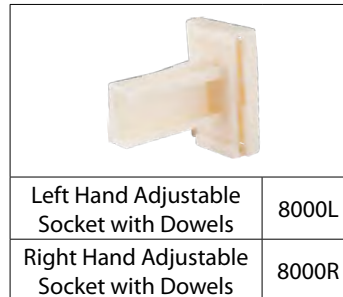

Left Hand Adjustable Socket with Dowels	8000L
Right Hand Adjustable Socket with Dowels	8000R

100 pcs/bag - 500 pcs/ctn

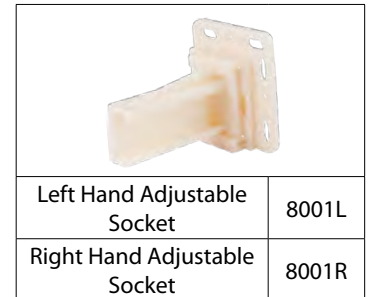

Left Hand Adjustable Socket	8001L
Right Hand Adjustable Socket	8001R

100 pcs/bag - 500 pcs/ctn

DRAWER MEMBER

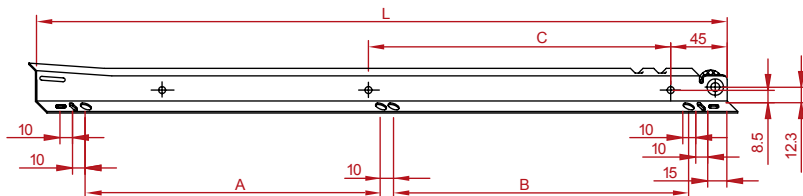

Hole Pattern and Length Specifications

Specifications	L	A	B	C
9400 - 16"	160	160	170	400
9450 - 18"	185	185	195	450
9500 - 20"	210	210	220	500
9550 - 22"	235	235	245	550

CABINET MEMBER

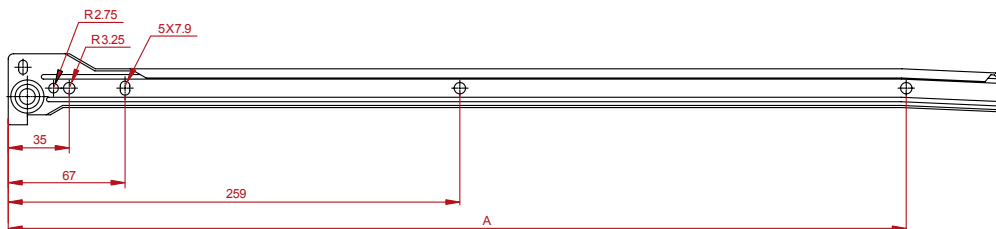

Specifications	A
9416 - 16"	355
9476 - 18"	387
9500 - 20"	451
9572 - 22"	515

Non-self-closing Double Captive Slides 4000 Series

Non-self-closing double captive slide designed specifically for use in either frameless or face frame applications.



Features

- 3/4" extension slide travel
- 100 lb. load rating
- Side or bottom mounting style for frameless and face frame cabinetry
- POM synthetic plastic roller, cylindrically ground for smooth and quiet action
- Double captive (left and right channels) reduces side play for on-track precision across the entire length of the slide
- Positive lock-out on both members
- Disconnects via lift out
- Non-self-closing

Specs

- 1-7/16" profile height
- 1/2" side spacing
- 1.0 mm cold rolled steel material
- Epoxy powdercoated cream white finish
- 32 mm system hole pattern
- 6.3 mm euro screw or #6 undercut screw is recommended

Cream White

Description	Part Number
19-3/4" (500 mm) Bulk Pack Cabinet Member	4050CL/CR
22-5/8" (575 mm) Bulk Pack Cabinet Member	4058CL/CR

*Compatible with 5000 Series Drawer Members 100 pcs/ctn

Mounting Brackets

Left and Right Hand Adjustable Brackets with Dowels	
6000 100 pr/bag 250 pr/ctn	
Left and Right Hand Adjustable Brackets (screw mount)	
6001 100 pr/bag 250 pr/ctn	

Hole Pattern and Length Specifications

CABINET MEMBER

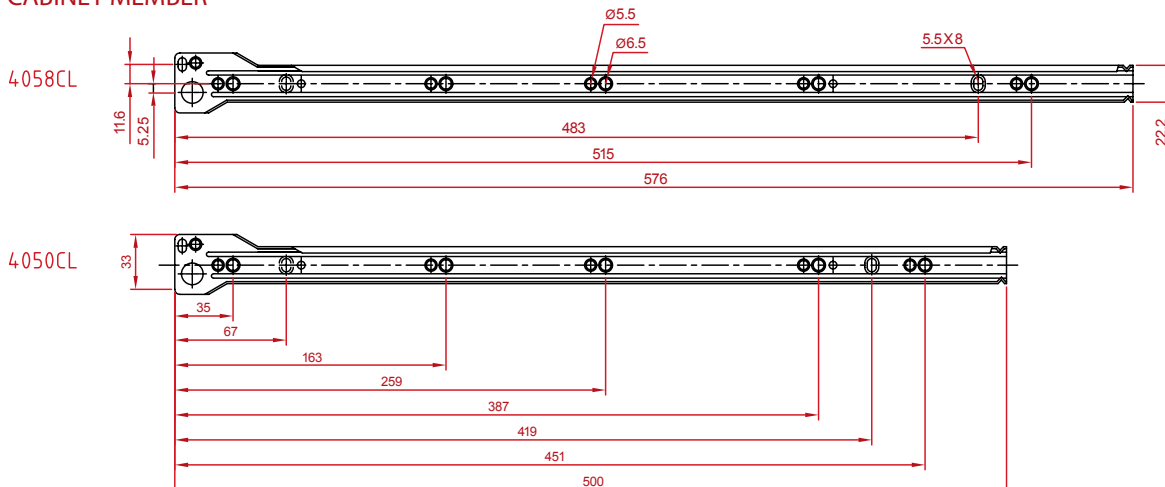

Screw Selection Guide

Screw Finishes



Ordering Options

All screws priced and sold by the thousand (K).
To calculate pricing multiply the quantity (Qty) by the price.



Keg Bucket

- The value package, available in our most popular screws
- Heavy duty and convenient way to take screws to the job site
- Avoid box tearing and breaking
- Bucket is reusable for many applications
- Lid securely snaps and stays in place



White Box

(all part #s ending in -B)

- Smaller order minimums
- 4 white inner boxes make up one master case
- You can purchase by the inner box or by the case



Economy Pack Box (all part #s ending in -2)

- Carton quantity is 2000 pcs
- Economy packed for lower inventory commitment
- Stocked in all warehouses for fast delivery on urgent jobs
- Select from our most popular hardware, assembly and installation screws

Example:

Description	Diameter x Length	Finish	Drive	Tip	Part #	Qty
Coarse Thread	#6 x 5/8"	Zinc	#2 Square	-	6X580Q-B	6 K
Coarse Thread	#6 x 5/8"	Zinc	#2 Square	Type 17	6X58017Q	25 K
Coarse Thread	#6 x 5/8"	Zinc	#2 Square	Type 17	6X58017Q-B	6 K
Coarse Thread	#6 x 5/8"	AB	Phillips	-	6X582	25 K
Coarse Thread	#6 x 5/8"	AB	Phillips	-	6X582-B	6 K

Qty x Price = Total price per package

Screw Selection Guide

Head Types *(measure length from surface of material to screw tip)*

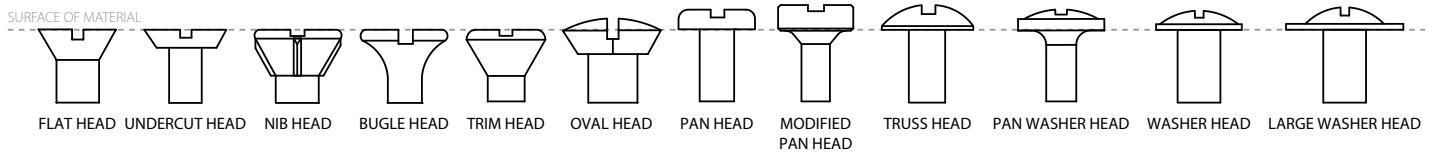

Head Sizes

	#4	#5	#6	#7	#8	#9	#10	#14
Flat Head	0.225"	0.252"	0.255"	0.295"	0.332"	0.335"	0.385"	0.491"
Oval Head		0.252"						
Pan Head			0.270"	0.296"	0.322"		0.373"	
Pocket Hole/Face Frame			Modified	Modified				
Truss Head			0.260"		0.384"			
Standard Washer Head					0.375"		0.500"	
Large Washer Head					0.500"			

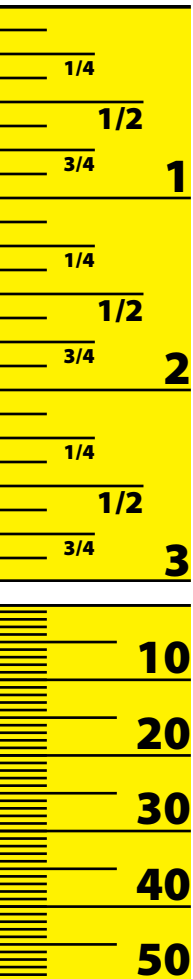

Drives



PHILLIPS

Most common in wood applications



PHILLIPS SLOTTED COMBO

Popular on truss head machine screws

Use Phillips bit to drive

Use Phillips or Flat bit to remove



POZI

Allows tight engagement, prevents stripping



POZI SLOTTED COMBO

Found on 2-piece connectors

Use Pozi bit to drive

Use Pozi or Flat bit to remove



SQUARE

Popular in hand-driven applications

Allows tight engagement, prevents stripping



PHILLIPS SQUARE COMBO

Allows tight engagement, prevents stripping

Use Square or Combo bit to drive

Use Square, Combo, or Phillips bit to remove



HEX

Found on drivers and draw bolts

TYPE 17

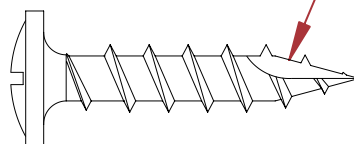

*NO BROKEN CARTONS. FULL CARTONS ONLY

	Item	Length	Drive	Material	Part #	Qty
	Bit	#2 x 1"	Phillips	Steel	3395	1 K
	Bit	#2 Reduced Shank x 1"	Phillips	Steel	3400	1 K
	Bit	#2 x 1"	Pozi	Steel	3407	1 K
	Bit	#2 Reduced Head x 1"	Pozi	Steel	3408	1 K
	Bit	#1 Reduced Head x 1"	Square	Steel	3402	1 K
	Bit	#1 x 1"	Square	Steel	3403	1 K
	Bit	#2 Reduced Head x 1"	Square	Steel	3404	1 K
	Bit	#2 x 1"	Square	Steel	3405	1 K
	Bit	#2 x 3"	Square	Steel	3406	1 K
	Bit	#2 x 6"	Square	Steel	S2-6DRIVE	.5 K
	Bit Holder	Two Piece Magnetic	1/4" Hex	Steel	3410	.25 K
	Bit Holder	One Piece Magnetic SS	1/4" Hex	Steel	3411	.25 K
	Bit Holder	Super Magnetic	1/4" Hex	Steel	3412	.25 K
	Screwdriver	4" Shaft. Hardened & Magnetized Tip.	#2 Pozi	-	HR-SCREW-DRIVER	1

Hardware Attachment Screws

*NO BROKEN CARTONS. FULL CARTONS ONLY

HINGES, PLATES & BRACKETS



Type 17

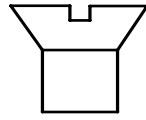

FLAT HEAD

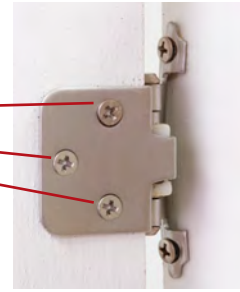

Description	Diameter x Length	Finish	Drive	Tip	Part #	Qty
Coarse Thread	#5 x 1/2"	Zinc	Phillips	-	5X120	35 K
Coarse Thread	#5 x 1/2"	Zinc	Phillips	-	5X120-B	10 K
Coarse Thread	#5 x 1/2"	Zinc	Phillips	-	5X120-2	2 K
Coarse Thread	#5 x 1/2"	Zinc	#1 Square	Type 17	5X120Q-B	10 K
Coarse Thread	#5 x 1/2"	AB	Phillips	-	5X122-B	10 K
Coarse Thread	#5 x 5/8"	Zinc	Phillips	-	5X580	30 K
Coarse Thread	#5 x 5/8"	Zinc	Phillips	-	5X580-B	7.5 K
Coarse Thread	#5 x 5/8"	Zinc	#1 Square	Type 17	5X580Q-B	7.5 K
Coarse Thread	#5 x 5/8"	AB	Phillips	-	5X582-B	7.5 K
Coarse Thread	#5 x 5/8"	Nickel	Phillips	-	5X581-B	7.5 K
Coarse Thread	#5 x 5/8"	PB	Phillips	-	5X583-B	7.5 K
Coarse Thread	#6 x 1/2"	Zinc	Phillips	-	6X120	25 K
Coarse Thread	#6 x 1/2"	Zinc	Phillips	-	6X120-B	6 K
Coarse Thread	#6 x 1/2"	Zinc	#2 Square	-	6X120Q	25 K
Coarse Thread	#6 x 1/2"	Zinc	#2 Square	-	6X120Q-B	6 K
Coarse Thread	#6 x 1/2"	Zinc	#2 Square	Type 17	6X12017Q-B	6 K
Coarse Thread	#6 x 1/2"	AB	Phillips	-	6X122	25 K
Coarse Thread	#6 x 1/2"	AB	#2 Square	Type 17	6X122Q-B	6 K
Coarse Thread	#6 x 1/2"	Nickel	Phillips	-	6X121	25 K
Coarse Thread	#6 x 1/2"	Nickel	Phillips	-	6X121-B	6 K
Coarse Thread	#6 x 1/2"	Black	#2 Square	-	6X120QB-B	6 K
Coarse Thread	#6 x 5/8"	Zinc	Phillips	-	6X580	25 K
Coarse Thread	#6 x 5/8"	Zinc	Phillips	-	6X580-B	6 K
Coarse Thread	#6 x 5/8"	Zinc	Phillips	-	6X580-2	2 K
Coarse Thread	#6 x 5/8"	Zinc	Phillips	Type 17	6X5800	25 K
Coarse Thread	#6 x 5/8"	Zinc	Phillips	Type 17	6X5800-B	6 K
Coarse Thread	#6 x 5/8"	Zinc	Phillips	Type 17	6X5800-2	2 K
Coarse Thread	#6 x 5/8"	Zinc	#2 Square	-	6X580Q	25 K

Hardware Attachment Screws

*NO BROKEN CARTONS. FULL CARTONS ONLY

**Screws &
Fasteners**

HINGES, PLATES & BRACKETS



Type 17

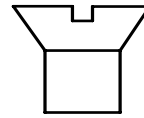

FLAT HEAD

Description	Diameter x Length	Finish	Drive	Tip	Part #	Qty
Coarse Thread	#6 x 5/8"	Zinc	#2 Square	-	6X580Q-B	6 K
Coarse Thread	#6 x 5/8"	Zinc	#2 Square	Type 17	6X58017Q	25 K
Coarse Thread	#6 x 5/8"	Zinc	#2 Square	Type 17	6X58017Q-B	6 K
Coarse Thread	#6 x 5/8"	AB	Phillips	-	6X582	25 K
Coarse Thread	#6 x 5/8"	AB	Phillips	-	6X582-B	6 K
Coarse Thread	#6 x 5/8"	AB	Phillips	Type 17	6X5802-B	6 K
Coarse Thread	#6 x 5/8"	Nickel	Phillips	-	6X581	25 K
Coarse Thread	#6 x 5/8"	Nickel	Phillips	-	6X581-B	6 K
Coarse Thread	#6 x 5/8"	Nickel	Phillips	Type 17	6X5801	25 K
Coarse Thread	#6 x 5/8"	Nickel	Phillips	Type 17	6X5801-B	6 K
Coarse Thread	#6 x 5/8"	PB	Phillips	Type 17	6X5803-B	6 K
Coarse Thread	#6 x 5/8"	White	Phillips	-	6X585-B	6 K
Coarse Thread	#6 x 5/8"	Almond	Phillips	-	6X588-B	6 K
Coarse Thread	#6 x 5/8"	Black	#2 Square	Type 17	6X580QB-BLK	.5 K
Coarse Thread	#6 x 3/4"	Zinc	Phillips	-	6X3400	20 K
Coarse Thread	#6 x 3/4"	Zinc	Phillips	-	6X3400-2	2 K
Coarse Thread	#6 x 3/4"	Zinc	Phillips	-	6X3400-B	5 K
Coarse Thread	#6 x 3/4"	Zinc	#2 Square	-	6X340Q	20 K
Coarse Thread	#6 x 3/4"	Zinc	#2 Square	-	6X340Q-B	5 K
Coarse Thread	#6 x 3/4"	Zinc	#2 Square	-	6X340Q-2	2 K
Coarse Thread	#6 x 3/4"	Zinc	Phillips	Type 17	6X3410	20 K
Coarse Thread	#6 x 3/4"	Zinc	Phillips	Type 17	6X3410-B	5 K
Coarse Thread	#6 x 3/4"	Zinc	#2 Square	Type 17	6X34017Q	20 K
Coarse Thread	#6 x 3/4"	Zinc	#2 Square	Type 17	6X34017Q-B	5 K
Coarse Thread	#6 x 3/4"	AB	Phillips	-	6X3402	20 K
Coarse Thread	#6 x 3/4"	AB	Phillips	-	6X3402-B	5 K
Coarse Thread	#6 x 3/4"	AB	Phillips	Type 17	6X3412	20 K
Coarse Thread	#6 x 3/4"	AB	Phillips	Type 17	6X3412-B	5 K

Hardware Attachment Screws

*NO BROKEN CARTONS. FULL CARTONS ONLY

HINGES, PLATES & BRACKETS



Coarse Thread

Type 17



Fine Thread

Type 17

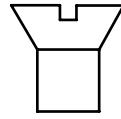

FLAT HEAD

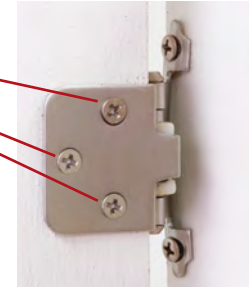

Description	Diameter x Length	Finish	Drive	Tip	Part #	Qty
Fine Thread	#6 x 5/8"	PB	Phillips	Type 17	6X58003	25 K
Fine Thread	#6 x 5/8"	White	Phillips	Type 17	6X58005-B	6 K
Coarse Thread	#6 x 3/4"	Nickel	Phillips	-	6X3401	20 K
Coarse Thread	#6 x 3/4"	Nickel	Phillips	-	6X3401-B	5 K
Coarse Thread	#6 x 3/4"	Almond	Phillips	-	6X3404-B	5 K
Coarse Thread	#6 x 3/4"	Almond	Phillips	Type 17	6X3414-B	5 K
Coarse Thread	#6 x 3/4"	DACM	Phillips	-	6X3406-B	5 K
Coarse Thread	#6 x 3/4"	PB	Phillips	-	6X3403-B	5 K
Coarse Thread	#6 x 3/4"	White	Phillips	-	6X3405-B	5 K
Coarse Thread	#6 x 3/4"	White	Phillips	Type 17	6X3415-B	5 K
Coarse Thread	#6 x 1"	Zinc	Phillips	-	6X10	20 K
Coarse Thread	#7 x 5/8"	Zinc	Phillips	-	7X580	20 K
Coarse Thread	#7 x 5/8"	Zinc	Phillips	-	7X580-B	5 K
Coarse Thread	#7 x 5/8"	Nickel	Phillips	-	7X581	20 K
Coarse Thread	#7 x 5/8"	Nickel	Phillips	-	7X581-B	5 K
Coarse Thread	#8 X 5/8"	Zinc	Phillips	-	8X5800	15 K
Coarse Thread	#8 X 5/8"	Zinc	Phillips	-	8X5800-B	3.5 K
Coarse Thread	#8 X 5/8"	Zinc	Phillips	Type 17	8X58170-B	3.5 K
Coarse Thread	#8 X 5/8"	AB	Phillips	-	8X5802-B	3.5 K
Coarse Thread	#8 X 5/8"	White	Phillips	-	8X5805-B	3.5 K
Coarse Thread	#8 X 3/4"	Zinc	Phillips	-	8X340	12 K
Coarse Thread	#8 X 3/4"	Zinc	Phillips	-	8X340-B	3 K
Coarse Thread	#8 X 3/4"	Zinc	Phillips	Type 17	8X34170	12 K
Coarse Thread	#8 X 3/4"	Zinc	Phillips	Type 17	8X34170-B	3 K
Coarse Thread	#8 X 3/4"	Almond	Phillips	-	8X344-B	3 K
Coarse Thread	#8 X 3/4"	AB	Phillips	Type 17	8X34172-B	3 K
Coarse Thread	#8 X 3/4"	DACM	Phillips	-	8X346-B	3 K
Coarse Thread	#8 X 3/4"	Nickel	Phillips	Type 17	8X34171-B	3 K

Hardware Attachment Screws

*NO BROKEN CARTONS. FULL CARTONS ONLY

Screws & Fasteners

MISC HARDWARE



Description	Diameter x Length	Finish	Drive	Tip	Part #	Qty
Coarse Thread	#6 x 1/2"	Zinc	Phillips	Type 17	6X1200	25 K
Coarse Thread	#6 x 1/2"	Zinc	Phillips	Type 17	6X1200-B	6 K
Coarse Thread	#6 x 1/2"	Zinc	Phillips	Type 17	6X1200-2	2 K
Coarse Thread	#6 x 1/2"	Zinc	#1 Square	Type 17	6X120017Q-B	6 K
Coarse Thread	#6 x 1/2"	Nickel	Phillips	-	6X1205-B	6 K
Coarse Thread	#6 x 1/2"	AB	#1 Square	Type 17	6X1202Q-B	6 K
Coarse Thread	#6 x 1/2"	Black	#1 Square	Type 17	6X1200QB-B	6 K
Coarse Thread	#6 x 5/8"	Zinc	Phillips	-	6X2580	20 K
Coarse Thread	#6 x 5/8"	Zinc	Phillips	-	6X2580-B	6 K
Coarse Thread	#6 x 5/8"	Zinc	#1 Square	Type 17	6X258017Q	20 K
Coarse Thread	#6 x 5/8"	Zinc	#1 Square	Type 17	6X258017Q-B	6 K
Coarse Thread	#6 x 5/8"	Zinc	Combo	Type 17	6X258017CH	20 K
Coarse Thread	#6 x 5/8"	AB	Phillips	-	6X2582	20 K
Coarse Thread	#6 x 5/8"	AB	Phillips	-	6X2582-B	6 K
Coarse Thread	#6 x 5/8"	Black	#1 Square	Type 17	6X2580QB	25 K
Coarse Thread	#6 x 3/4"	Zinc	Phillips	-	6X2340-B	1 K
Coarse Thread	#6 x 3/4"	Nickel	Phillips	-	6X2345-B	5 K
Coarse Thread	#8 x 5/8"	Zinc	Phillips	-	8X580	14 K
Coarse Thread	#8 x 5/8"	Zinc	Phillips	-	8X580-B	3.5 K
Coarse Thread	#8 x 3/4"	Zinc	Phillips	Type 17	8X3400	11 K
Coarse Thread	#8 x 3/4"	Zinc	Phillips	Type 17	8X3400-B	2.5 K
Coarse Thread	#8 x 3/4"	Zinc	#2 Square	Type 17	8X3400Q	11 K
Coarse Thread	#8 x 3/4"	Zinc	#2 Square	Type 17	8X3400Q-B	2.5 K
Coarse Thread	#10 x 5/8"	Zinc	Phillips	Type 17	10X580	10 K
Coarse Thread	#10 x 3/4"	Zinc	Phillips	Type 17	10X340-B	2 K

Hardware Attachment Screws

*NO BROKEN CARTONS. FULL CARTONS ONLY

FURNITURE HARDWARE

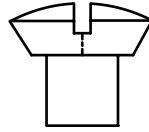

OVAL HEAD

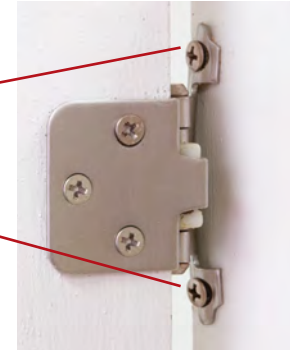

Description	Diameter x Length	Finish	Drive	Tip	Part #	Qty
Coarse Thread	#5 x 5/8"	AB	Phillips	-	5X585	30 K
Coarse Thread	#5 x 5/8"	AB	Phillips	-	5X585-B	7.5 K
Coarse Thread	#5 x 5/8"	PB	Phillips	-	5X586	30 K
Coarse Thread	#5 x 5/8"	DACM	Phillips	-	5X588-B	7.5 K
Coarse Thread	#5 x 5/8"	Nickel	Phillips	-	5X587-B	7.5 K
Coarse Thread	#6 x 5/8"	AB	#2 Square	-	6X585Q	25 K

COMPACT HINGES



Type 17

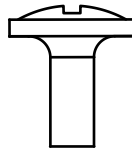

PAN WASHER HEAD



Description	Diameter x Length	Finish	Drive	Tip	Part #	Qty
Coarse Thread	#7 x 5/8"	Zinc	Combo	Type 17	7X0580WCQ	18 K
Coarse Thread	#7 x 5/8"	Zinc	Combo	Type 17	7X0580WCQ-2	2 K
Coarse Thread	#8 x 5/8"	Zinc	#2 Square	Type 17	8X058017WCQ-B	3.5 K
Coarse Thread	#8 x 3/4"	Zinc	#2 Square	Type 17	8X034017WCQ	11 K
Coarse Thread	#8 x 3/4"	Zinc	#2 Square	Type 17	8X034017WCQ-B	3 K
Coarse Thread	#8 x 1-1/4"	Clear Brown Wax	#2 Square	-	8X114917WCQ	6 K
Coarse Thread	#8 x 2"	Clear Brown Wax	#2 Square	-	8X200917WCQ	3.5 K
Coarse Thread	#8 x 2-1/2"	Clear Brown Wax	#2 Square	-	8X212917WCQ	2.5 K
Coarse Thread	#9 x 3"	Clear Brown Wax	#2 Square	-	9X300917WCQ	2 K

Hardware Attachment Screws

*NO BROKEN CARTONS. FULL CARTONS ONLY

EPOXY SLIDES

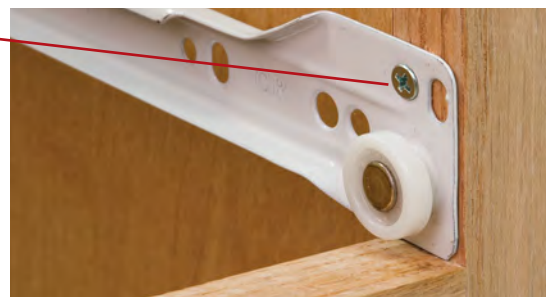
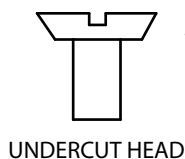
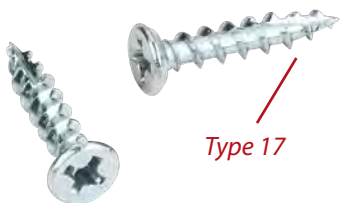

Description	Diameter x Length	Finish	Drive	Tip	Part #	Qty
Coarse Thread	#6 x 1/2"	Zinc	Phillips	-	6U121	25 K
Coarse Thread	#6 x 1/2"	Zinc	#1 Square	-	6X1120Q	25 K
Coarse Thread	#6 x 1/2"	Zinc	Phillips	-	6U121-B	6 K
Coarse Thread	#6 x 1/2"	Zinc	#1 Square	Type 17	6U121Q	25 K
Coarse Thread	#6 x 1/2"	Zinc	#1 Square	Type 17	6U121Q-B	6 K
Coarse Thread	#6 x 1/2"	Black	#1 Square	Type 17	6U121QB-B	6 K
Coarse Thread	#6 x 5/8"	Zinc	Phillips	-	6U581	20 K
Coarse Thread	#6 x 5/8"	Zinc	Phillips	-	6U581-B	6 K
Coarse Thread	#6 x 5/8"	Zinc	#1 Square	Type 17	6U581Q-B	6 K
Coarse Thread	#6 x 3/4"	Zinc	Phillips	Type 17	6X340	20 K
Coarse Thread	#6 x 3/4"	Zinc	Phillips	Type 17	6X340-B	5 K

BALL BEARING SLIDES

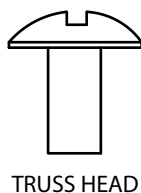

Description	Diameter x Length	Finish	Drive	Tip	Part #	Qty
Coarse Thread	#6 x 7/16"	Zinc	Phillips	-	6X7160	25 K
Coarse Thread	#6 x 7/16"	Zinc	Phillips	-	6X7160-B	6 K
Coarse Thread	#6 x 7/16"	Zinc	#2 Square	-	6X7160Q	25 K
Coarse Thread	#6 x 1/2"	Zinc	Phillips	-	6X1120Q	25 K
Coarse Thread	#8 x 7/16"	Zinc	Phillips	-	8X7160	20 K
Coarse Thread	#8 x 7/16"	Zinc	Phillips	-	8X7160-B	5 K
Coarse Thread	#8 x 7/16"	Zinc	Phillips	-	8X7160-2	2 K
Coarse Thread	#8 x 7/16"	Zinc	Combo	-	8X7160CQ	20 K
Coarse Thread	#8 x 7/16"	Zinc	Combo	-	8X7160CQ-B	5 K
Coarse Thread	#8 x 7/16"	Black	Combo	-	8X7160CQB	20 K
Coarse Thread	#8 x 5/8"	AB	#2 Square	-	8X1580Q	14 K

Hardware Attachment Screws

*NO BROKEN CARTONS. FULL CARTONS ONLY

EUROPEAN DRAWER SLIDES

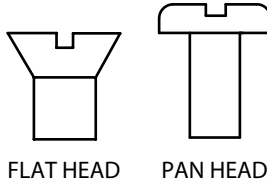

FLAT HEAD PAN HEAD

Description	Diameter x Length	Finish	Drive	Tip	Part #	Qty
Flat Head Euro	6.3 mm x 18 mm	Zinc	#2 Square	-	6071Q-B	2.5 K
Flat Head Euro	7 mm x 9 mm	Nickel	Pozi	-	6021-B	4.5 K
Flat Head Euro	7 mm x 10.5 mm	Nickel	Pozi	-	6041-B	4.5 K
Flat Head Euro	7 mm x 10.5 mm	Nickel	#2 Square	-	6041Q-B	4.5 K
Flat Head Euro	7 mm x 11.5 mm	Nickel	Pozi	-	6051-B	4 K
Flat Head Euro	7 mm x 13 mm	Nickel	Pozi	-	6061-B	3.5 K
Flat Head Euro	7 mm x 13 mm	Nickel	#2 Square	-	6061Q-B	3.5 K
Flat Head Euro	7 mm x 14.5 mm	Nickel	Pozi	-	6065-B	2.5 K
Flat Head Euro	7 mm x 18 mm	Nickel	Pozi	-	6071-B	2.5 K
Flat Head Euro	7.5 mm x 10 mm	Nickel	Phillips	-	7031-B	4 K
Flat Head Euro	7.5 mm x 13 mm	Nickel	Phillips	-	7061-B	3 K
Pan Head Euro	9 mm x 13.2 mm	Nickel	Phillips	-	1005194-B	2.5 K

KNOBS & PULLS

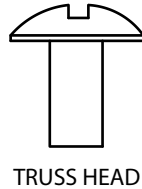

TRUSS HEAD

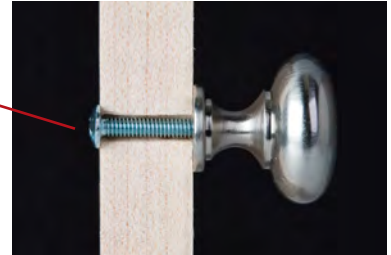

Description	Diameter x Length	Finish	Drive	Tip	Part #	Qty
Machine	8-32 x 5/8"	Zinc	Phillips	-	32X0580-B	2.5 K
Machine	8-32 x 3/4"	Zinc	Combo	-	32X0340-B	1.5 K
Machine	8-32 x 7/8"	Zinc	Combo	-	32X0780-B	2.5 K
Machine	8-32 x 1"	Zinc	Combo	-	32X1001-B	1.5 K
Machine	8-32 x 1-1/8"	Zinc	Combo	-	32X1181-B	1 K
Machine	8-32 x 1-1/4"	Zinc	Combo	-	32X1141-B	1 K
Machine	8-32 x 1-3/8"	Zinc	Phillips	-	32X1381-B	1 K
Machine	8-32 x 1-1/2"	Zinc	Combo	-	32X1121-B	1 K
Machine	8-32 x 1-5/8"	Zinc	Combo	-	32X1581-B	1 K
Machine	8-32 x 1-3/4"	Zinc	Combo	-	32X1341-B	1 K
Machine	8-32 x 1-7/8"	Zinc	Combo	-	32X1781-B	1 K
Machine	8-32 x 2"	Zinc	Phillips	-	32X2001-B	1 K
Break Away Machine	8-32 x 1-3/4"	Zinc	Combo	-	32BREAK	4 K
Break Away Machine	8-32 x 1-3/4"	Zinc	Combo	-	32BREAK-B	1 K
Break Away Machine	M4 x 45 mm	Zinc	Combo	-	M4BREAK	4 K

Cabinet Assembly Screws

*NO BROKEN CARTONS. FULL CARTONS ONLY

**Screws &
Fasteners**

FLAT HEAD WITH NIB

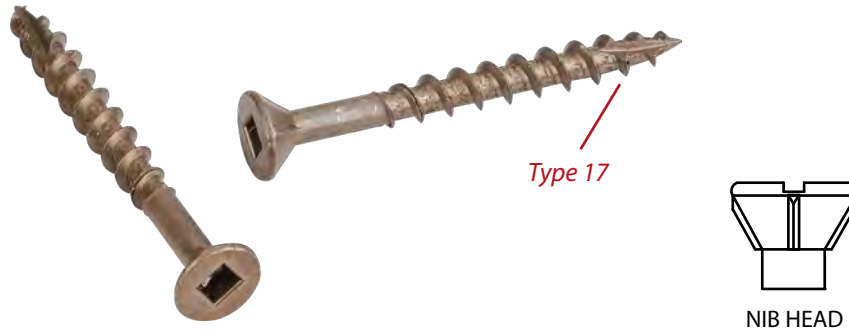

Description	Diameter x Length	Finish	Drive	Tip	Part #	Qty
Coarse Thread	#8 x 1"	Clear Brown Wax	Phillips	Type 17	8X100917	10 K
Coarse Thread	#8 x 1"	Clear Brown Wax	#2 Square	Type 17	8X100917Q	10 K
Coarse Thread	#8 x 1"	Zinc	Combo	Type 17	8X1000	10 K
Coarse Thread	#8 x 1"	Zinc	Combo	Type 17	8X1000-2	2 K
Coarse Thread	#8 x 1-1/8"	Zinc	Combo	Type 17	8X1180	8 K
Coarse Thread	#8 x 1-1/4"	Clear Brown Wax	Phillips	Type 17	8X114917	8 K
Coarse Thread	#8 x 1-1/4"	Clear Brown Wax	#2 Square	Type 17	8X114917Q	8 K
Coarse Thread	#8 x 1-1/4"	Clear Brown Wax	#2 Square	Type 17	8X114917Q-2	2 K
Coarse Thread	#8 x 1-1/4"	Zinc	Combo	Type 17	8X1140	8 K
Coarse Thread	#8 x 1-1/4"	Zinc	Combo	Type 17	8X1140-2	2 K
Coarse Thread	#8 x 1-1/2"	Clear Brown Wax	Phillips	Type 17	8X112917	6 K
Coarse Thread	#8 x 1-1/2"	Clear Brown Wax	#2 Square	Type 17	8X112917Q	6 K
Coarse Thread	#8 x 1-1/2"	Zinc	Combo	Type 17	8X1120	6 K
Coarse Thread	#8 x 1-5/8"	Clear Brown Wax	Phillips	Type 17	8X158917	5 K
Coarse Thread	#8 x 1-5/8"	Clear Brown Wax	#2 Square	Type 17	8X158917Q	5 K
Coarse Thread	#8 x 1-5/8"	Zinc	Combo	Type 17	8X1580	5 K
Coarse Thread	#8 x 1-3/4"	Clear Brown Wax	#2 Square	Type 17	8X134917Q	5 K
Coarse Thread	#8 x 1-3/4"	Zinc	Combo	Type 17	8X1340	5 K
Coarse Thread	#8 x 2"	Clear Brown Wax	Phillips	Type 17	8X200917	4 K
Coarse Thread	#8 x 2"	Clear Brown Wax	#2 Square	Type 17	8X200917Q	4 K
Coarse Thread	#8 x 2"	Zinc	Combo	Type 17	8X2000	4.3 K
Coarse Thread	#9 x 2-1/4"	Clear Brown Wax	#2 Square	Type 17	9X214917Q	2.5 K
Coarse Thread	#9 x 2-1/2"	Clear Brown Wax	#2 Square	Type 17	9X212917Q	2.5 K
Coarse Thread	#9 x 2-1/2"	Zinc	Combo	Type 17	9X2120	2.5 K
Coarse Thread	#9 x 3"	Clear Brown Wax	Phillips	Type 17	9X300917	2.3 K
Coarse Thread	#9 x 3"	Clear Brown Wax	#2 Square	Type 17	9X300917Q	2.3 K
Coarse Thread	#9 x 3"	Zinc	Combo	Type 17	9X3000	2.3 K

Cabinet Assembly/Installation Screws

*NO BROKEN CARTONS. FULL CARTONS ONLY

TRIM HEAD FINISHING

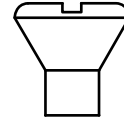

TRIM HEAD

Description	Diameter x Length	Finish	Drive	Tip	Part #	Qty
Coarse Thread	#6 x 1-5/8"	Black Plated	#1 Square	-	6X158	5 K
Coarse Thread	#6 x 2-1/4"	Black Plated	#1 Square	-	6X214	5 K

POCKET HOLE/FACE FRAME



Type 17

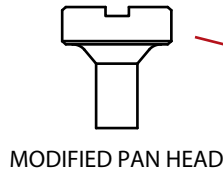

MODIFIED PAN HEAD

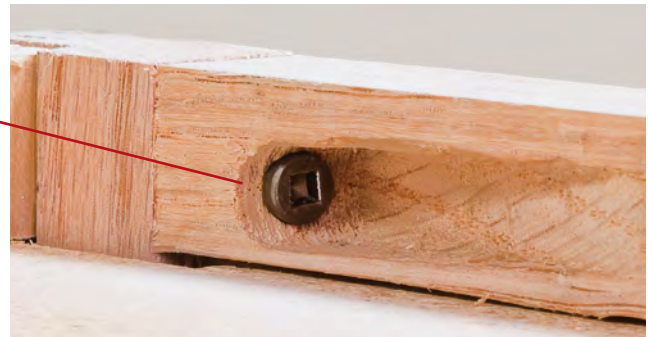

Description	Diameter x Length	Finish	Drive	Tip	Part #	Qty
Coarse Thread	#6 x 1-1/4"	Clear Brown Wax	#2 Square	Type 17	6X1141	8 K
Coarse Thread	#7 x 1-1/2"	Clear Brown Wax	#2 Square	Type 17	7X11504	7 K
Fine Thread	#6 x 1-1/4"	Clear Brown Wax	#2 Square	Type 17	6X1140	8 K
Fine Thread	#6 x 1-1/2"	Clear Brown Wax	#2 Square	Type 17	6X1120	7 K

BUGLE HEAD DRYWALL

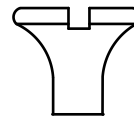

BUGLE HEAD

Description	Diameter x Length	Finish	Drive	Tip	Part #	Qty
Coarse Thread	#6 x 1"	Black Plated	Phillips	-	6110BUG	10 K
Coarse Thread	#6 x 1-1/4"	Black Plated	Phillips	-	6114BUG	8 K
Coarse Thread	#6 x 1-5/8"	Black Plated	Phillips	-	6158BUG	5 K
Coarse Thread	#6 x 2"	Black Plated	Phillips	-	6200BUG	4.5 K
Coarse Thread	#8 x 2-1/2"	Black Plated	Phillips	-	8200BUG	2.5 K
Coarse Thread	#8 x 3"	Black Plated	Phillips	-	8300BUG	2.3 K
Coarse Thread	#8 x 3"	Zinc	#2 Square	-	8X300	2.3 K

Cabinet Installation Screws

*NO BROKEN CARTONS. FULL CARTONS ONLY

**Screws &
Fasteners**

STANDARD WASHER HEAD

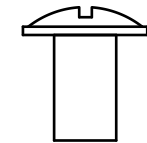

WASHER HEAD

Description	Diameter x Length	Finish	Drive	Tip	Part #	Qty
Coarse Thread	#8 x 1/2"	Black	#2 Square	Type 17	8X012017QB	15 K
Coarse Thread	#8 x 5/8"	Black	#2 Square	Type 17	8X058017QB	15 K
Coarse Thread	#8 x 3/4"	Black	#2 Square	Type 17	8X034017QB	11 K
Coarse Thread	#8 x 1"	Black	#2 Square	Type 17	8X100017QB	10 K
Coarse Thread	#8 x 1-1/8"	Zinc	Combo	Type 17	8X118017WCH	5 K
Coarse Thread	#8 x 1-1/4"	Zinc	Combo	Type 17	8X114017WCH	4 K
Coarse Thread	#8 x 1-1/4"	Black	#2 Square	Type 17	8X114017QB	6 K
Coarse Thread	#8 x 1-1/2"	Zinc	Combo	Type 17	8X112017WCH	5.5K
Coarse Thread	#8 x 1-1/2"	Black	#2 Square	Type 17	8X112017QB	5.5 K
Coarse Thread	#8 x 1-3/4"	Black	#2 Square	Type 17	8X13401QB	5 K
Coarse Thread	#8 x 2"	Zinc	Combo	Type 17	8X200017WCH	3.5K
Coarse Thread	#8 x 2"	Black	#2 Square	Type 17	8X200017QB	3.5 K
Coarse Thread	#8 x 2-1/2"	Zinc	Combo	Type 17	8X25017WCH	2.5 K
Coarse Thread	#8 x 2-1/2"	Black	#2 Square	Type 17	8X25017QB	2.5 K
Coarse Thread	#8 x 3"	Zinc	Combo	Type 17	8X3000W	2 K
Coarse Thread	#8 x 3"	White	Combo	Type 17	8X3000WH	2 K
Coarse Thread	#8 x 3"	Black	#2 Square	Type 17	8X300017QB	2 K
Coarse Thread	#10 x 3"	Clear Brown Wax	Combo	Type 17	10X3000W	1.6 K
Coarse Thread	#10 x 3"	White	Combo	Type 17	10X3000WH	1.6 K
Coarse Thread	#14 x 3"	Zinc	#2 Square	Type 17	14X30017B	1 K

Cabinet Installation & Specialty Screws

*NO BROKEN CARTONS. FULL CARTONS ONLY

DRAWER FRONT



Type 17

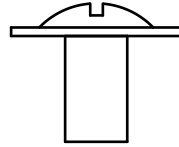

LARGE WASHER HEAD



Description	Diameter x Length	Finish	Drive	Tip	Part #	Qty
Coarse Thread	#8 x 7/8"	Zinc	Phillips	-	8X1078W	6 K
Coarse Thread	#8 x 7/8"	Zinc	#2 Square	Type 17	8X1078WQ	6 K
Coarse Thread	#8 x 1"	Zinc	Phillips	-	8X1000W	7 K
Coarse Thread	#8 x 1"	Zinc	#2 Square	Type 17	8X100017WQ	7 K
Coarse Thread	#8 x 1-1/8"	Zinc	Phillips	-	8X1180W	5 K
Coarse Thread	#8 x 1-1/8"	Zinc	#2 Square	Type 17	8X118017WQ	5 K
Coarse Thread	#8 x 1-1/8"	Zinc	#2 Square	Type 17	8X118017WQ-2	2 K
Coarse Thread	#8 x 1-1/4"	Zinc	Phillips	-	8X1140W	5 K
Coarse Thread	#8 x 1-1/4"	Zinc	#2 Square	Type 17	8X114017WQ	5 K

SPECIALTY



Confirmat screw

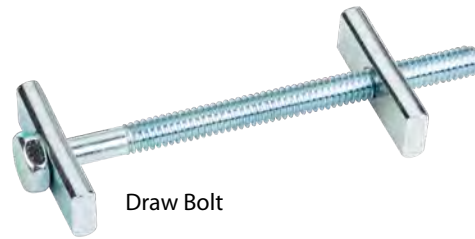

Draw Bolt

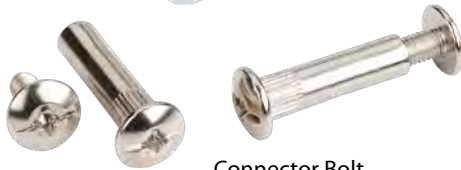

Connector Bolt



Wall Anchor







Countersunk Finishing Washer

Description	Diameter x Length	Finish	Drive	Tip	Part #	Qty
Confirmat Flat Head	7 mm x 50 mm	Zinc	Pozi	Blunt	HR7X50-B	.5 K
Confirmat Flat Head	7 mm x 50 mm	Zinc	Pozi	Pointed	HR7X50P-B	.5 K
Draw Bolt	7/16" Hex x 3-5/8"	Zinc	Hex	-	322	.45 K
Connector Bolt	5 mm x 35-45 mm	Nickel	Pozi	-	565NP35-B	.6 K
Wall Anchor	#6-#8 x 3/8"-5/8"	Zinc	Phillips	-	8X158ZN	.5 K
Countersunk Finishing Washer	For #6-#7 Screw	Nickel	-	-	8FW-B	7.5 K
Countersunk Finishing Washer	For #8-#9 Screw	Nickel	-	-	10FW-B	6 K
Connector Bolt	8 mm x 31-41 mm	Nickel	Pozi	-	555NP31-B	.4 K

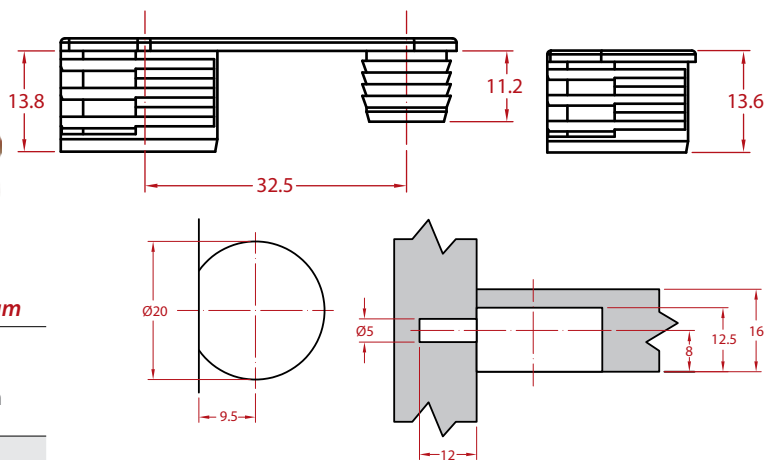
Panel Connectors

All measurements shown in mm



	<i>Double Connector Cam</i>	<i>Connector Cam</i>
	Brown Plastic 9C19-BRN 250 pcs/ctn	8C19-BRN 250 pcs/ctn
	White Plastic 9C19-WH 250 pcs/ctn	8C19-WH 250 pcs/ctn
	Zinc with Nickel Plating 9C19-ZN 250 pcs/ctn	8C19-ZN 250 pcs/ctn

- » Plastic or zinc housing
- » Zinc tightening element
- » For use with 19 mm thickness material
- » 14 mm drilling depth



Metal Cam

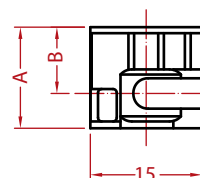

16 mm material	7C16 250 pcs/ctn
19 mm material	7C19 250 pcs/ctn

- » Zinc die cast
- » Center locking position 9 mm
- » Drilling depth: 14.0–0.05 mm

	A	B
7C16	12.2 mm	7.5 mm
7C19	13.6 mm	9 mm



Connecting Bolt

11 mm length	5C11 250 pcs/ctn*
36 mm length	5C36 250 pcs/ctn*
40 mm length	5C40 250 pcs/ctn*

*NO BROKEN BOXES.
FULL BOXES ONLY

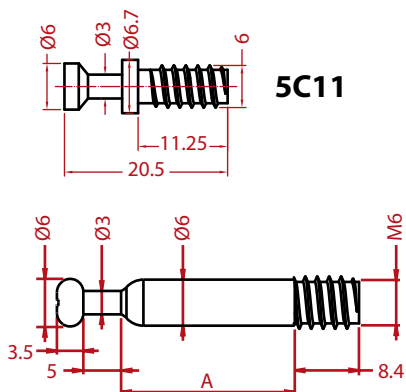

	A
5C36	19 mm
5C40	23 mm

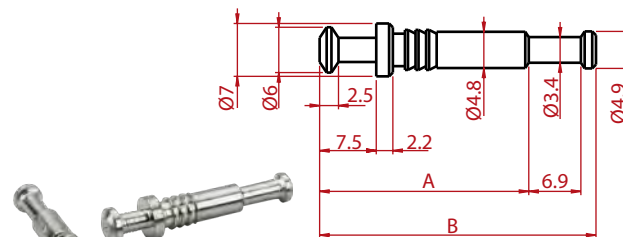

Center Panel Double Bolt

16 mm material	6C16 250 pcs/ctn
19 mm material	6C19 250 pcs/ctn

	A	B
6C16	24.7 mm	33.6 mm
6C19	27.7 mm	36.6 mm

Shutter Hinges Non-Mortise

Loose Pin

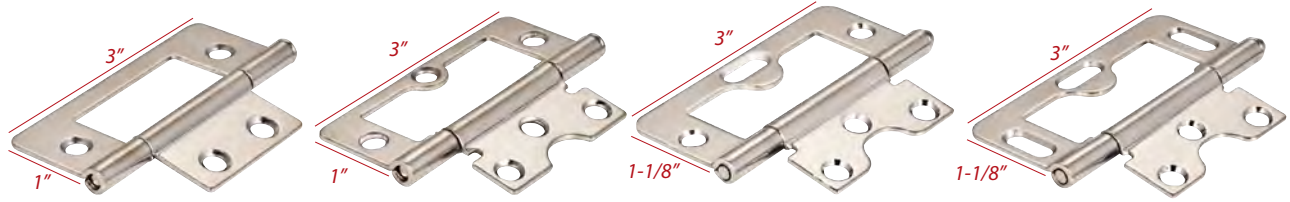

	<i>3" Swaged - 4 Holes</i>	<i>3" Swaged - 6 Holes</i>	<i>3" Swaged - 1 Slot</i>	<i>3" Swaged - 3 Slots</i>
Almond	9500ALM	9802ALM	9805ALM	9806ALM
Antique Brass	9500AB	9802AB	9805AB	9806AB
Bright Nickel	9500BN	9802BN	9805BN	9806BN
Bright White	9500BWH	9802BWH	9805BWH	
Brushed Chrome	9500BC	9802BC		
Dark Antique Copper Machined	9500DACM	9802DACM	9805DACM	9806DACM
Dull White	9500WH-D			
Polished Brass	9500PB	9802PB	9805PB	
White	9500WH	9802WH	9805WH	9806WH
<i>Recommended screw:</i>	<i>#6 x 5/8" flat head</i>	<i>#6 x 5/8" flat head</i>	<i>#6 x 5/8" flat head</i>	<i>#6 x 5/8" flat head</i>
	50 pcs/box 250 pcs/master	50 pcs/box 250 pcs/master	50 pcs/box 250 pcs/master	50 pcs/box 250 pcs/master

Shutter Hinges Non-Mortise

Shutter
Hardware

Fixed Pin

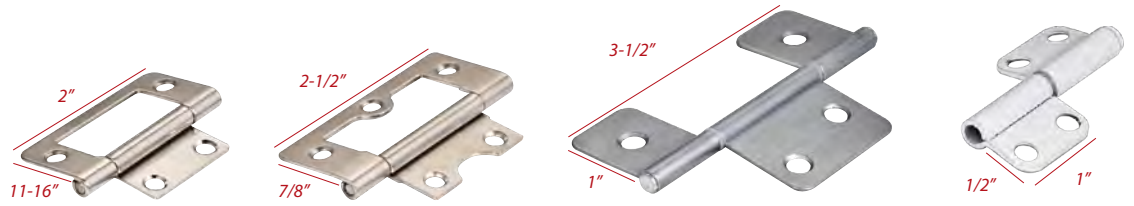

2" Flat Back

2-1/2" Flat Back

3-1/2" Swaged 3 Leaf

2-1/16" Swaged Lift Off

Almond			20251-ALMS	
Antique Brass	9800AB	9801AB	20251AB	
Antique Copper	9800AC	9801AC		
Black	9800BLK			
Bright Nickel			20251BN	
Bright White			20251BWH	
Brushed Chrome			20251BC	
Dark Antique Copper Machined			20251DACM	
Polished Brass	9800PB		20251PB	
White			20251-WHS	20200WH-LH 20200WH - RH
Recommended screw:	#4 x 5/8" flat head	#5 x 5/8" flat head	#6 x 5/8" flat head	#5 x 5/8" flat head
	50 pcs/box 500 pcs/master	50 pcs/box 500 pcs/master	100 pcs/box 500 pcs/master	100 pcs/box 500 pcs/master
				•Sold in Left Hand and Right Hand

Shutter Hinges Butt

Swaged or Not Swaged...What Hinge Do I Need?

<p>PLAIN HINGE Neither leaf is swaged, the leaves lie flat in the same plane in an open position.</p>	
<p>SINGLE FULL SWAGED HINGE One leaf is fully swaged providing relief for offset mounting.</p>	
<p>SINGLE HALF SWAGED HINGE One leaf is half swaged for certain mounting requirements.</p>	
<p>DOUBLE HALF SWAGED HINGE Both leaves are half swaged with minimum clearance between the leaves when closed.</p>	

Single Half Swaged

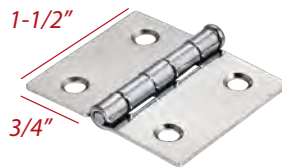

1-1/2" x 1-3/4"



2-1/2" x 1-1/2"

Almond		33527ALM
Antique Brass		33527AB
Bright Nickel		33527BN
Bright White		33527BWH
Brushed Chrome		33527BC
Dark Antique Copper Machined		33527DACM
Polished Brass		33527PB
Prime Coat	20160PR	33527PR
Stainless Steel		33527SS
White		33527WH
Recommended screw:	#5 x 5/8" flat head	#6 x 5/8" flat head

250 pcs/box
1000 pcs/master

100 pcs/box
500 pcs/master

Shutter Hinges

Single Full Swaged

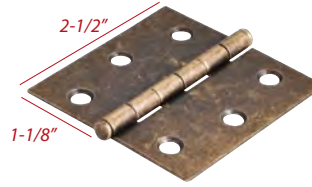

	<i>2-1/2" x 1-11/16"</i>	<i>2-1/2" x 2" Radius Corner</i>	<i>2-1/2" x 2-1/2"</i>	<i>3" x 2-3/4"</i>
Almond		33530ALM	33524ALM	
Antique Brass	33528AB	33530AB	33524AB	OL33550AB
Bright Nickel	33528BN		33524BN	OL33550BN
Bright White	33528BWH	33530BWH	33524BWH	OL33550BWH
Brushed Chrome		33530BC	33524BC	OL33550BC
Dark Antique Copper Machined		33530DACM	33524DACM	OL33550DACM
Off White			33524OWH	
Polished Brass	33528PB	33530PB	33524PB	OL33550PB
Prime Coat		33530PR	33524PR	OL33550PR
Stainless Steel			33524SS	OL33550SS
White	33528WH	33530WH	33524WH	OL33550WH
Recommended screw:	#6 x 5/8" flat head	#6 x 5/8" flat head	#6 x 3/4" flat head	#8 x 3/4" flat head
	100 pcs/box 500 pcs/master	100 pcs/box 400 pcs/master	50 pcs/box 250 pcs/master	50 pcs/box 200 pcs/master

Single Full Swaged

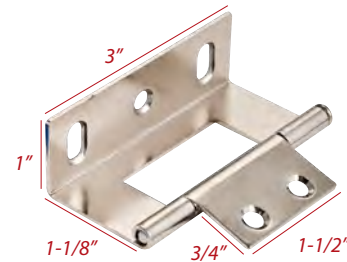
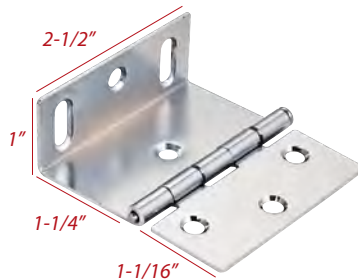

	<i>2-1/2" - 2 Slots</i>	<i>3" Non Mortise - 2 Slots</i>
Almond	54050ALM	95050ALM
Antique Brass	54050AB	
Bright Nickel	54050BN	
Bright White	54050BWH	95050BWH
Brushed Chrome	54050BC	
Dark Antique Copper Machined	54050DACM	95050DACM
Polished Brass	54050PB	
Prime Coat	54050PR	
Recommended screw:	#6 x 3/4" flat head	#6 x 3/4" flat head
	50 pcs/box 2500 pcs/master	50 pcs/box 2500 pcs/master

Shutter Hardware

Louvers Pins

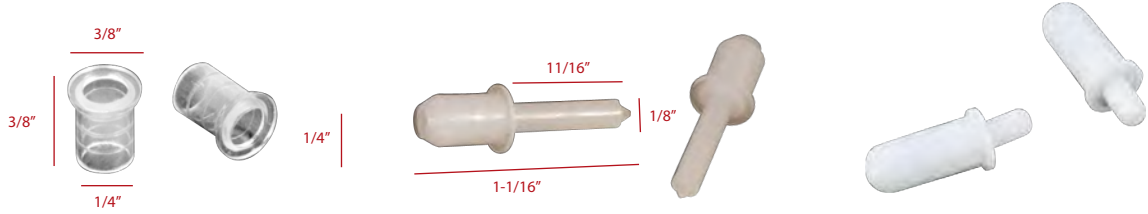

Flange Bushing

Louver Pin

Spring Loaded Louver Pin

Clear	LP5000		
Nylon/Natural		LP1000	
White			LP2000
	20 K/ctn	15 K/ctn	10 K/ctn

Button Catches



Reverse Clip L Mount

Inside Clip

Button

Polished Brass	50604	50614	
Zinc	50600	50610	506B0
Recommended screw:	#5 x 5/8" flat head	#5 x 5/8" flat head	
	100 receivers + 100 buttons/box	100 receivers + 100 buttons/box	5000 buttons/ctn
	500 receivers + 500 buttons/master	500 receivers + 500 buttons/master	

Shelf Supports Angled

Shelf
Supports

5 mm Pin Diameter

- » Solid steel construction
- » 3/4" long arm
- » Available in cartons of 1000 pcs



	<i>Standard</i>	<i>With 1/8" Hole</i>	<i>With Brown Sleeve</i>	<i>With Almond Sleeve</i>	<i>With White Sleeve</i>	<i>With Clear Sleeve</i>	<i>With Diamond Hole</i>
Antique Brass	1706AB	1707AB	1708AB				
Antique Copper		1707AC	1708AC				1710AC
Black		1707BLK					
Bright Nickel	1706BN	1707BN	1708BN		1708WBN	1708CBN	1710BN
Polished Brass	1706PB	1707PB		1708APB			

1000 pcs/ctn*

1000 pcs/ctn*

1000 pcs/ctn*

1000 pcs/ctn*

1000 pcs/ctn*

1000 pcs/ctn*

1000 pcs/ctn*



***NO BROKEN CARTONS. FULL CARTONS ONLY**

1/4" Pin Diameter

- » Solid steel construction
- » 3/4" long arm
- » Available in cartons of 1000 pcs



	<i>Standard</i>	<i>With 1/8" Hole</i>	<i>With Brown Sleeve</i>	<i>With Brown Sleeve & 7/8" Long Arm</i>
Antique Brass	1609AB	1610AB		
Antique Copper		1610AC	1611AC	1915AC
Bright Nickel	1609BN	1610BN		
Polished Brass		1610PB	1611PB	

1000 pcs/ctn*

1000 pcs/ctn*

1000 pcs/ctn*

1000 pcs/ctn*

***NO BROKEN CARTONS. FULL CARTONS ONLY**

Shelf Supports Spoon

3 mm Pin Diameter



Spoon

Bright Nickel	1103BN
---------------	--------

1000 pcs/box*
10,000 pcs/ctn

**NO BROKEN BOXES. FULL BOXES ONLY*

- » Solid steel construction
- » Available in boxes of 1000 pcs and 10,000 pcs master carton

5 mm Pin Diameter



Spoon



**Spoon with
Anti-Slide Barb**



**Grommet
5.5 mm drill Ø**

Antique Brass	1306AB		1283AB
Antique Copper	1306AC		
Black	1306BLK		1283BLK
Bright Nickel	1306BN	1306BN-2	1283BN
Polished Brass	1306PB		1283PB

1000 pcs/box*
6000 pcs/ctn 1000 pcs/box*
6000 pcs/ctn 1000 pcs/box*
5000 pcs/ctn

**NO BROKEN BOXES. FULL BOXES ONLY*

- » Solid steel construction
- » Anti-slide barb cuts into shelf and prevents shelf movement (1306BN-2)
- » Supports available in boxes of 1000 pcs and 6000 pcs master carton
- » Grommets available in boxes of 1000 pcs and 5000 pcs master carton



1/4" Pin Diameter



Spoon



**Grommet
7.5 mm drill Ø**

Antique Brass	1206AB	1284AB
Antique Copper	1206AC	1284AC
Black	1206BLK	1284BLK
Bright Nickel	1206BN	1284BN
Polished Brass	1206PB	1284PB

1000 pcs/box*
6000 pcs/ctn 1000 pcs/box*
5000 pcs/ctn

**NO BROKEN BOXES. FULL BOXES ONLY*

- » Solid steel construction
- » Supports available in boxes of 1000 pcs and 6000 pcs master carton
- » Grommets available in boxes of 1000 pcs and 5000 pcs master carton



Sleeve

Brown	101BRN
-------	--------

20,000 ps/ctn

- » Durable synthetic rubber
- » Can be used on any plated finish

Shelf Supports

Standards & Clips



- » Single track standards fit in 5/8" wide groove
- » Standards quickly install using nails or screws (not included)
- » Available in a variety of sizes which can also be cut to length
- » Clips snap into place in 3/8" increments for a secure fit and can be easily removed and reattached.
- » #5 or #6 flat head screw recommended for installation

	<i>Standard Clip Bulk Pack</i>	<i>Standard Clip Builder Pack</i>	<i>Standard Clip Retail Pack</i>	<i>48" Standard</i>	<i>60" Standard</i>	<i>72" Standard</i>	<i>96" Standard</i>
Brass		1460BR	1460BR-R				
Brown		1460AC	1460AC-R	TRK01-48BRN	TRK01-60BRN	TRK01-72BRN	TRK01-96BRN
Nickel/ Zinc	460NI	1460NI	1460ZN-R	TRK01-48ZN	TRK01-60ZN	TRK01-72ZN	TRK01-96ZN
White		1460WH	1460WH-R	TRK01-48WH	TRK01-60WH	TRK01-72WH	TRK01-96WH
	2500 pcs/ctn*	1000 pcs/ctn*	20 pcs/pack 100 pks/ctn*	20 pcs/ctn*	20 pcs/ctn*	20 pcs/ctn*	20 pcs/ctn*

**NO BROKEN CARTONS. FULL CARTONS ONLY*

Zinc Supports - 5 mm Pin



*Support with 5 mm
Shelf Hold Pin*

Zinc	1545ZN
	1000 pcs/box*
	5000 pcs/ctn

**NO BROKEN BOXES. FULL BOXES ONLY*

- » Solid zinc die cast construction
- » Available in boxes of 1000 pcs and 5000 pcs master carton



Plastic Supports - 5 mm Pin



Support

Almond	1438ALM
Brown	1438BRN
Clear	1438CL
White	1438WH

1000 pcs/box*
5000 pcs/ctn

**NO BROKEN BOXES. FULL BOXES ONLY*

- » Synthetic injection molded plastic with steel pin
- » Available in boxes of 1000 pcs and 5000 pcs master carton

Shelf Supports

5 mm Pins



16 mm Duplo 24 mm Straight 30 mm Straight 45 mm Straight

Antique Copper	1401AC			
Bright Nickel		1402BN	418BN	1400BN
Zinc	1401ZN	1402ZN		
	1000 pcs/ctn*	1000 pcs/ctn*	1000 pcs/ctn*	1000 pcs/ctn*

**NO BROKEN CARTONS. FULL CARTONS ONLY*

- » Solid steel construction
- » Available in cartons of 1000 pcs

Plastic Shelf Locks



- » Highly durable synthetic plastic construction
- » Available in a variety of pin diameters and shelf thickness combinations

	5 mm Pin 1/2" Shelf	5 mm Pin 5/8" Shelf	5 mm Pin 3/4" Shelf	1/4" Pin 5/8" Shelf	1/4" Pin 3/4" Shelf
Clear	7703CL	7704CL	7705CL	8704CL	8705CL
White			7705WH		
	1750 pcs/box* 3500 pcs/ctn	2000 pcs/box* 4000 pcs/ctn	2500 pcs/box* 5000 pcs/ctn	1750 pcs/box* 3500 pcs/ctn	1750 pcs/box* 3500 pcs/ctn

**NO BROKEN BOXES. FULL BOXES ONLY*

Heavy Duty Plastic Shelf Lock



	5 mm Double Pin 3/4" or 1" Shelf
Clear	7706CL
	2000 pcs/ctn*

**NO BROKEN CARTONS. FULL CARTONS ONLY*

- » 500 lb. weight rating per set of 4
- » Highly durable synthetic plastic construction
- » Fits 3/4" or 1" shelf thickness
- » Two pins are 32 mm spaced
- » ANSI/BHMA A156.9-2003 Grade 1

Decorative Hinges Self-closing

Decorative
Hinges

Overlay Hinge - Face Frame Mount

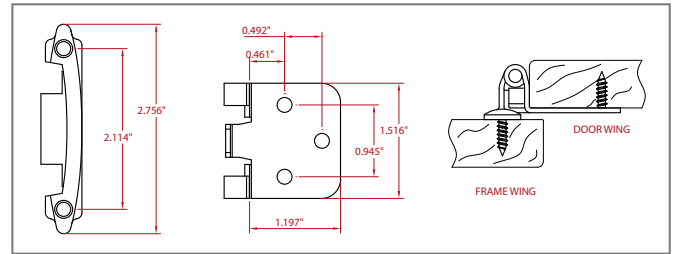

	<i>Bulk Pack</i>	<i>Retail Pack</i>
Antique Brass		P5011AB
Black Powder Coat	H5011BLK	
Brushed Dull Nickel	H5011BNBDL	
Burnished Brass	H5011BB	P5011BB
Dark Antique Copper Machined	H5011DACM	P5011DACM
Dark Brushed Antique Copper	H5011DBAC	P5011DBAC
Polished Brass	H5011PB	P5011PB
Polished Chrome	H5011PC	P5011PC
Satin Nickel	H5011SN	P5011SN
White		P5011WH
	125 pr/ctn	1 pr/polybag 100 pks/ctn

- » Traditional overlay hinge with semi-concealed frame wing
- » Steel construction with reliable power pack for firm self-closure
- » #5 x 5/8" oval head screw recommended for face frame attachment and #6 x 1/2" flat head screw recommended for door attachment
- » Retail packs are polybagged with UPC label and contain: 2 hinges, 4 finished screws for face frame attachment, 6 finished screws for door attachment and 2 door bumpers

3/8" Inset Hinge - Face Frame Mount

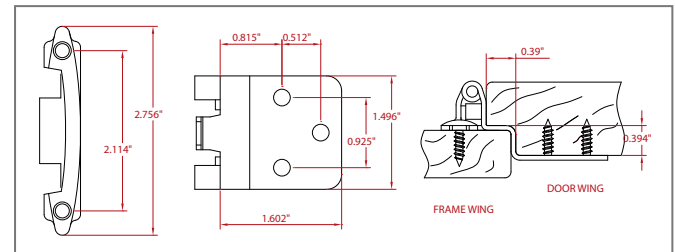
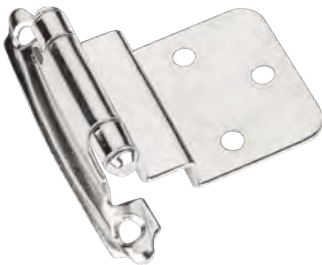

	<i>Bulk Pack</i>	<i>Retail Pack</i>
Antique Brass		P5922AB
Burnished Brass	H5922BB	
Dark Antique Copper Machined		P5922DACM
Dark Brushed Antique Copper		P5922DBAC
Polished Brass		P5922PB
Polished Chrome		P5922PC
Satin Nickel		P5922SN
	125 pr/ctn	1 pr/polybag 100 pks/ctn

- » Traditional 3/8" inset hinge with semi-concealed frame wing
- » Steel construction with reliable power pack for firm self-closure
- » #5 x 5/8" oval head screw recommended for face frame attachment and #6 x 1/2" flat head screw recommended for door attachment
- » Retail packs are polybagged with UPC label and contain: 2 hinges, 4 finished screws for face frame attachment, 6 finished screws for door attachment and 2 door bumpers

Decorative Hinges Self-closing

Full Wrap Around Hinge - 3 Hole Door Mount, 1/2" Overlay



Bulk Pack

Antique Brass	H6541AB
Burnished Brass	H6541BB
Satin Nickel	H6541SN

100pr/ctn

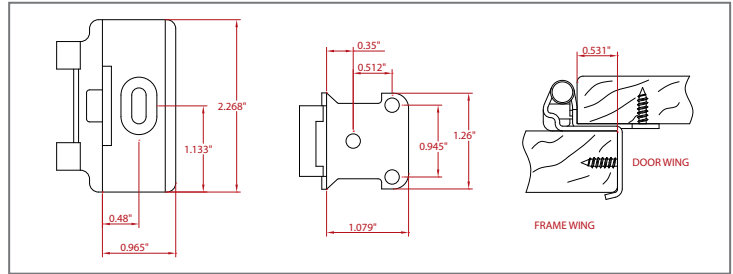

- » For 3/4" frame and 1/2" overlay applications
- » Steel construction with reliable power pack for firm self-closure
- » #6 x 5/8" flat head screw recommended for fast single-point attachment to face frame and #6 x 1/2" flat head screws recommended for door attachment
- » Slotted face frame hole provides vertical adjustment

Full Wrap Around Hinge - 2 Hole Door Mount, 1/2" Overlay



Bulk Pack

Burnished Brass	H6441BB
Satin Nickel	H6441SN

100 pr/ctn

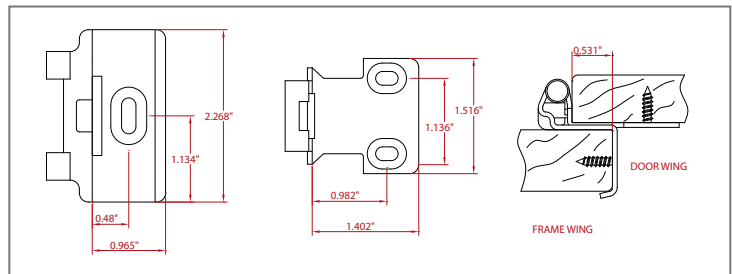

- » For 3/4" frame and 1/2" overlay applications
- » Steel construction with reliable power pack for firm self-closure
- » #6 x 5/8" flat head screw recommended for fast single-point attachment to face frame and #6 x 1/2" flat head screw recommended for door attachment
- » Slotted face frame and door holes provide horizontal and vertical adjustment

Decorative Hinges Self-closing

Decorative
Hinges

Partial Wrap Around Hinge - 3 Hole Door Mount, 1/2" Overlay



Bulk Pack

Burnished Brass

H7441BB

200 pr/ctn

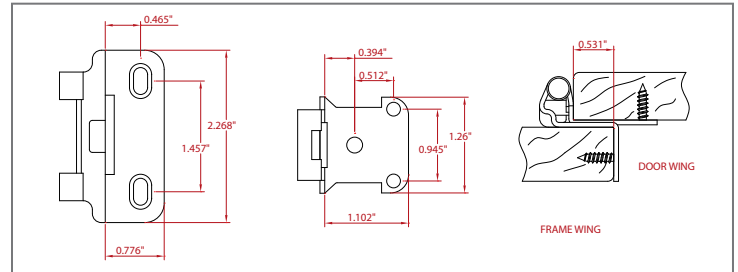

- » For 3/4" frame and 1/2" overlay applications
- » Steel construction with reliable power pack for firm self-closure
- » #6 x 5/8" flat head screw recommended for attachment to face frame and #6 x 1/2" flat head screw recommended for door attachment
- » Slotted face frame holes provide vertical adjustment

Partial Wrap Around Hinge - 2 Hole Door Mount, 1/2" Overlay



Bulk Pack

Burnished Brass

H5349BB

125 pr/ctn

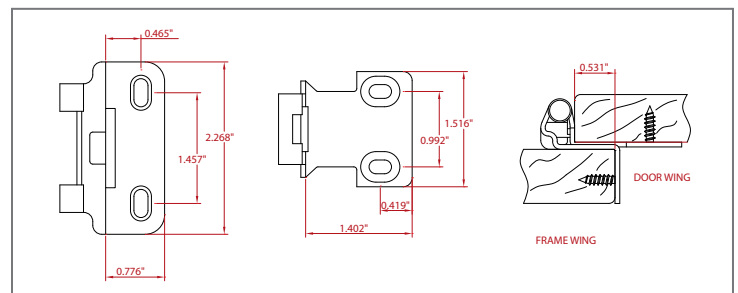

- » For 3/4" frame and 1/2" overlay applications
- » Steel construction with reliable power pack for firm self-closure
- » #6 x 5/8" flat head screw recommended for attachment to face frame and #6 x 1/2" flat head screw recommended for door attachment
- » Slotted face frame and door holes provide horizontal and vertical adjustment
- » Conforms to ANSI/BHMA for Grade 2

Decorative Hinges Free-swinging

Full Wrap Around Hinge - Full Inset Ball Tip



Bulk Pack

Antique Brass	0128AB
Dark Brushed Antique Copper	0128DBAC
Matte Black	0128MB
Satin Nickel	0128SN

250 pcs/ctn

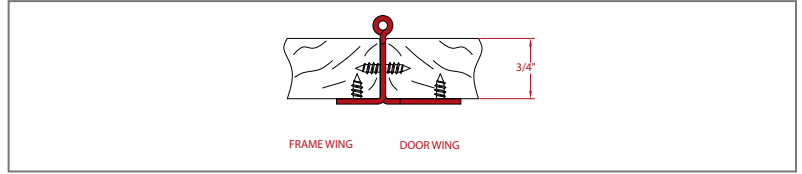

- » For 3/4" frame and 3/4" door, 270° opening
- » For full inset frame applications
- » Stylish ball tips for shaker style cabinets with raised panel doors
- » Non-mortise hinge quickly installs and yields minimal door gap
- » #6 x 5/8" flat head screw recommended for attachment to frame and #6 x 1/2" flat head screw recommended for door attachment
- » Slotted holes provide horizontal and vertical adjustment

Full Wrap Around Hinge - Full Inset Minaret Tip



Bulk Pack

Dark Brushed Antique Copper	0138DBAC
Matte Black	0138MB
Polished Nickel	0138NI
Satin Nickel	0138SN

20 pcs/box
200 pcs/master

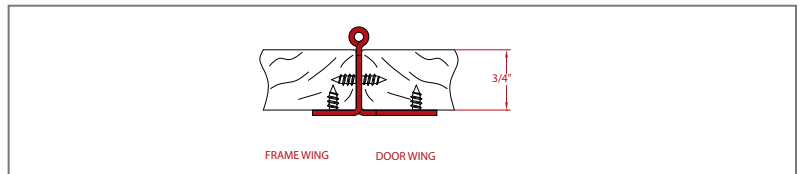

- » For 3/4" frame and 3/4" door, 270° opening
- » For full inset frame applications
- » Stylish minaret tips for shaker style cabinets with raised panel doors
- » Non-mortise hinge quickly installs and yields minimal door gap
- » #6 x 5/8" flat head screw recommended for attachment to frame and #6 x 1/2" flat head screw recommended for door attachment
- » Slotted holes provide horizontal and vertical adjustment
- » Designed for use with Jeffrey Alexander cabinet latch (item # CL101)

Decorative Hinges Free-swinging

Decorative
Hinges

Full Wrap Around Hinge - Offset Bifold



Bulk Pack

Polished Brass	9915PB
400 pcs/ctn	

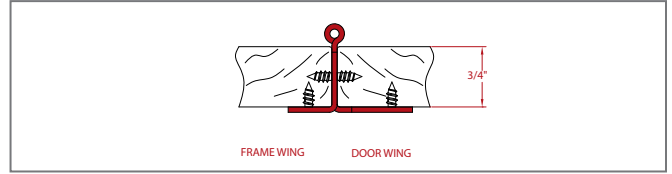

- » For 3/4" frame and 3/4" door, 180° opening
- » For offset applications
- » Non-mortise hinge quickly installs and yields minimal door gap
- » #6 x 5/8" flat head screw recommended for attachment to frame and #6 x 1/2" flat head screw recommended for door attachment
- » Slotted holes provide horizontal and vertical adjustment

Partial Wrap Around Hinge - Full Inset "A" Style Minaret Tip



Bulk Pack

Antique Brass	0148AB
Dark Brushed Antique Copper	0148DBAC
Matte Black	0148MB
Satin Nickel	0148SN

250 pcs/ctn

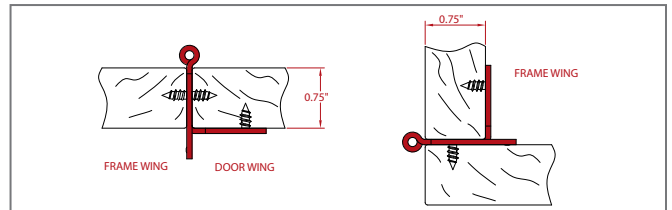

- » For 3/4" frame and 3/4" door, 270° opening
- » For full inset face frame applications
- » "A" style slim form minaret tips for shaker style cabinets with raised panel doors
- » Non-mortise hinge quickly installs and yields minimal door gap
- » #6 x 5/8" flat head screw recommended for attachment to frame and #6 x 1/2" flat head screw recommended for door attachment
- » Slotted holes provide vertical adjustment

Decorative Hinges Free-swinging

Partial Wrap Around Hinge - Full Inset "B" Style Minaret Tip



Bulk Pack

Dark Brushed Antique Copper	0158DBAC
Polished Nickel	0158NI
Satin Nickel	0158SN

50 pcs/box
300 pcs/master

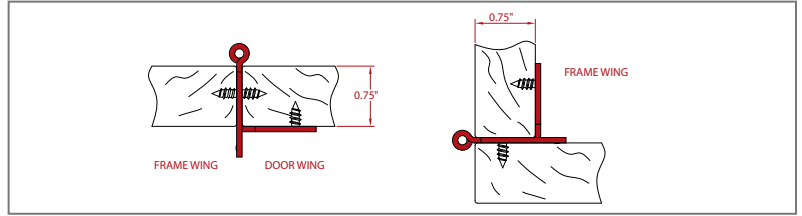

- » For 3/4" frame and 3/4" door, 270° opening
- » For full inset face frame applications
- » "B" style rounded minaret tips for shaker style cabinets with raised panel doors
- » Non-mortise hinge quickly installs and yields minimal door gap
- » #6 x 5/8" flat head screw recommended for attachment to frame and #6 x 1/2" flat head screw recommended for door attachment
- » Slotted holes provide vertical adjustment
- » Designed for use with Jeffrey Alexander cabinet latch

Tall Partial Wrap Around Hinge - Full Inset Minaret Tip



Bulk Pack

Dark Brushed Antique Copper	0178DBAC
Polished Nickel	0178NI
Satin Nickel	0178SN

50 pcs/box
200 pcs/master

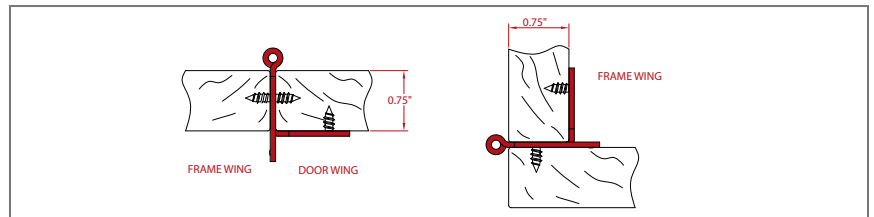

- » For 3/4" frame and 3/4" door, 270° opening
- » For full inset face frame applications
- » Minaret tips for shaker style cabinets with raised panel doors
- » Non-mortise hinge quickly installs and yields minimal door gap
- » #6 x 5/8" flat head screw recommended for attachment to frame and #6 x 1/2" flat head screw recommended for door attachment
- » Slotted holes provide vertical adjustment
- » Designed for use with Jeffrey Alexander cabinet latch (item # CL101)

5 Knuckle Overlay Hinge



Bulk Pack

Almond Powder Coat	HR0076AL
Black Powder Coat	HR0076BLK
Dull Chrome (26D)	HR0076
Polished Brass	HR0076PB
Stainless Steel (304)	HR0076SS
White Powder Coat	HR0076WH
Recommended screw:	#8 flat head or Euro

108 pcs/box

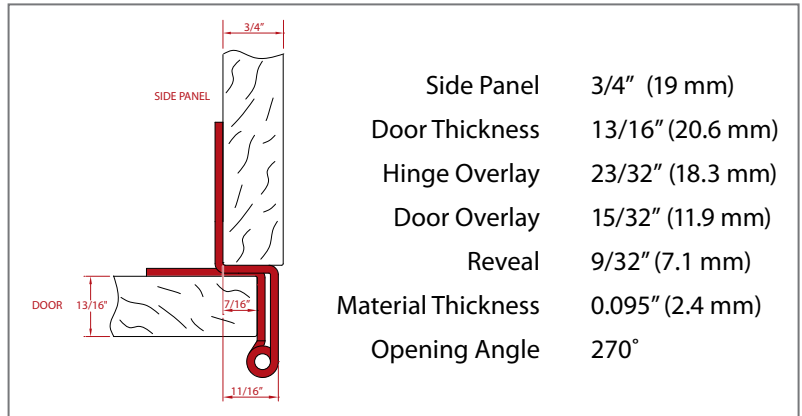

Side Panel	3/4" (19 mm)
Door Thickness	13/16" (20.6 mm)
Hinge Overlay	23/32" (18.3 mm)
Door Overlay	15/32" (11.9 mm)
Reveal	9/32" (7.1 mm)
Material Thickness	0.095" (2.4 mm)
Opening Angle	270°

- » Conforms to ANSI/BHMA Grade 1 Requirements
- » Hospital tips, 2-3/4" overall height
- » 32 mm system hole pattern with 37 mm setback
- » Countersunk screw holes for recommended #8 flat head or Euro screws
- » Stainless steel #8 x 3/4" flathead screw available (8X347-2)

3 Knuckle Heavy Duty Hinge



Bulk Pack

Black Powder Coat	9975BLK
Bright Nickel	9975BN

100 pcs/ctn

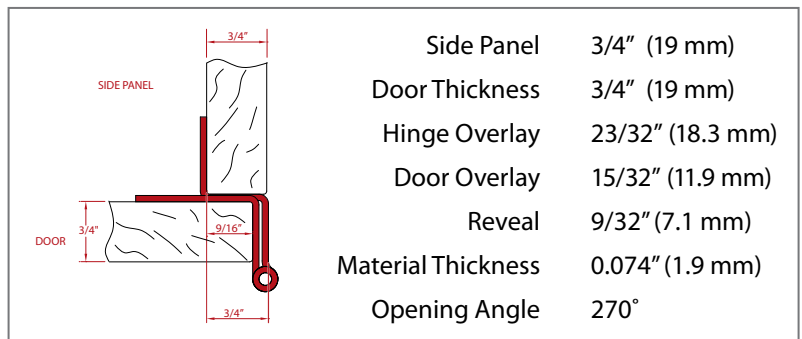

Side Panel	3/4" (19 mm)
Door Thickness	3/4" (19 mm)
Hinge Overlay	23/32" (18.3 mm)
Door Overlay	15/32" (11.9 mm)
Reveal	9/32" (7.1 mm)
Material Thickness	0.074" (1.9 mm)
Opening Angle	270°

- » Decorative ball tips, 2-5/16" overall height
- » Drilled knuckle inner diameter
- » 32 mm system hole pattern

Institutional Hinges

3 Knuckle Medium Duty Hinge

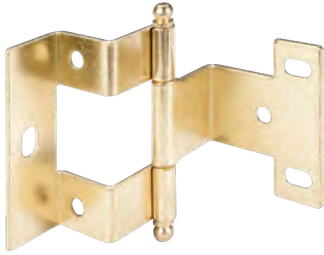

Bulk Pack

Polished Brass

9925PB

300 pcs/ctn

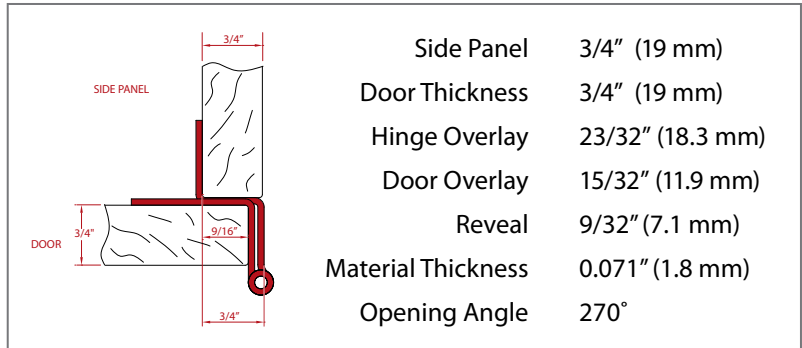

Single Pivot Institutional Hinge



Bulk Pack

Nickel

HR0086

Recommended
screw:

#8 pan head

100 pcs/ctn

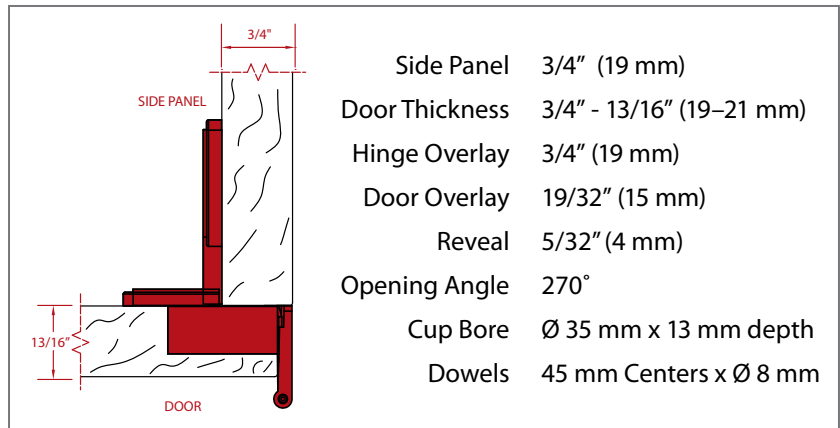

- » Solid zinc die cast construction
- » Cup ships with 8 mm dowels
- » Integrated polymer catch with positive lock
- » Conforms to ANSI/BHMA Grade 1 Requirements

Specialty Decorative Hinges

1/2" Overlay Knife Hinge

NEW



Bulk Pack

White Plastic	KH-12WH
Antique Brass	KH-12AB

50 pcs/ctn

- » Full 180° opening with single pivot point
- » For face frame or frameless application
- » Slotted holes for vertical and horizontal adjustment
- » 9/32" saw cut with 6-1/2" dado
- » Non-handed design works on left- or right-handed door

Continuous (Piano) Hinge



Boxed

Bright Nickel	5414
Polished Brass	5413
Recommended screw:	#6 flat head

25 pcs/ctn

- » 21-gauge steel (0.035")
- » 1-1/2" open width, 11/16" leaf width
- » Ships in 6' pieces
- » 2" hole spacing, 1/4" knuckle length

Butler Tray Hinge



Polybag Pack

Brass	BTH-12
-------	--------

36 pcs/ctn

- » Stop holds hinge flat in horizontal position
- » Hinge mortises flush into surface of table
- » Hinge folds up 90 degrees and stops
- » Sold individually with screws included

False Front Clips



18.25 mm



21 mm Extended



Roller/Spacer

Black Plated	FFC11BLK	FFC12BLK
White		FFS11
Recommended screw:	#6 flat head	#6 flat head

5000 pcs/ctn

2500 pcs/ctn

5000 pcs/ctn

- » Designed to attach finished cabinet fronts to cabinet openings with little or no usage
- » Perfect for sink base cabinets in kitchens and bathrooms

Door Bumpers

		<i>Height</i>	<i>Diameter</i>	<i>Material</i>	<i>Color</i>
	HR7438 320 pcs/sheet 20,000 pcs/ctn	3/32"	3/8"	Rubber	Black
	85303CL 200 pcs/sheet 5000 pcs/ctn	5 mm	1/2"	Transparent Polyurethane	Clear
	85101CL 200 pcs/sheet 5000 pcs/ctn	3.5 mm	7/16"	Transparent Polyurethane	Clear
	85202CL 450 pcs/sheet 5400 pcs/ctn	2.2 mm	5/16"	Transparent Polyurethane	Clear



- » Quick and versatile installation using adhesive backing
- » Can be used on a wide variety of doors and drawers
- » 85303CL specially designed for cabinet hinges; soft-durometer two stage impact resistance greatly reduces noise

Locks



7/8" Zinc Die Cast Drawer Lock

Brass Keyed Alike	1060BR
Chrome Keyed Different	1060CH

1 pc/bag
250 pcs/ctn

- » Standard 7/8" (22 mm) length with straight cam
- » Screws mount on 35 mm center
- » 180° angle of rotation
- » 2 keys included per bag
- » Master keying not available

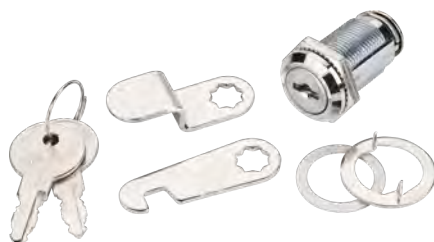

Zinc Die Cast Drawer Lock

	<i>1-1/8"</i>	<i>1-1/2"</i>
Chrome Keyed Alike	68639CH	78739CH
Chrome Keyed Different	68639CHKD	78739CHKD

1 pc/bag
200 pcs/ctn

- » Fork cam and 3/8" offset cam for flush applications
- » Body mounts with hex nut and prong washer into 3/4" (19 mm) diameter hole
- » 90° angle of rotation
- » 2 keys included per bag
- » For plastic, metal or wood applications
- » Master keying not available



Strike Plate for Cam Locks

Bright Nickel	7000201BN
---------------	-----------

Recommended screw: #8 washer head

500 pcs/ctn

- » Long-lasting steel construction
- » Screw-on mount

Catches

Magnetic Catches



	8 lb. Single Polybagged	15 lb. Single Polybagged	15 lb. Single Retail Pack	15 lb. Single Bulk Pack
Brown/Bronze	50635	50632	50632-R	50636
White/Polished Brass		50633		50634
White/White		50639		
White/Zinc		50631	50631-R	50630
Pack Contents	1 strike plate, 1 catch, 1pc #5 x 5/8" flat head, 2pcs #6 x 3/4" pan head	1 strike plate, 1 catch, 1pc #5 x 5/8" flat head, 2pcs #6 x 3/4" pan head	1 strike plate, 1 catch, 1pc #5 x 5/8" flat head, 2pcs #6 x 3/4" pan head	
	100 pks/box 1000 pks/master	100 pks/box 1000 pks/master	65 pks/box 520 pks/master	1000 catches 1000 strike plates 1000 flat head 2000 pan head



	15 lb. Double Polybagged	15 lb. Double Retail Packed	25 lb. Single Polybagged	25 lb. Single Bulk Pack
Brown/Bronze	50622	50622-R	50652	
White/Polished Brass	50623		50653	50654
White/Zinc	50621	50621-R	50651	50650
Pack Contents	2 strike plates, 1 catch, 2pcs #5 x 5/8" flat head, 2pcs #6 x 3/4" pan head	2 strike plates, 1 catch, 2pcs #5 x 5/8" flat head, 2pcs #6 x 3/4" pan head	1 strike plate, 1 catch, 1pc #5 x 5/8" flat head, 2pcs #6 x 3/4" pan head	
	100 pks/box 600 pks/master	40 pks/box 320 pks/master	50 pks/box 500 pks/master	500 catches 500 strike plates 500 flat head 1000 pan head

Catches

Roller Catches



Retail Packed

Dark Brushed
Antique Copper

RC01-DBAC

Polished Brass

RC01-PB

Zinc

RC01-ZN

Pack Contents

1 catch, 1 strike, 4 screws

400 pks/ctn

- » Double roller catch with durable nylon rollers
- » Roller measures 33 mm wide x 28 mm deep x 14 mm tall
- » Mounting holes are 24 mm center-to-center
- » 4 pcs pan head wood screws included
- » Bagged with catch, strike and screws with UPC label for retail sale

Elbow Catches



Retail Packed

Dark Brushed
Antique Copper

EC01-DBAC

Polished Brass

EC01-PB

Zinc

EC01-ZN

Pack Contents

1 catch, 1 strike, 4 screws

125 pks/box
500 pks/master

- » Steel construction
- » Catch measures 28 mm wide x 26 mm tall
- » Strike plate measures 27 mm long x 12 mm wide
- » Catch mounting holes are 17 mm center-to-center
- » 4 pcs pan head wood screws included
- » Bagged with catch, strike and screws with UPC label for retail sale

Magnetic Touch Latches



Black

506L2

White

506L1

*Recommended
screw:*

#6 x 3/4" pan head

600 pcs/ctn

Overall Height	18 mm
Base Length	33 mm
Base Width	28 mm
Extended Overall Length	51 mm
Retracted Overall Length	41 mm
Hole Spacing	18 mm

Rectangular Strike Plate



Bronze

506S2

White

506S4

Zinc

506S1

*Recommended
screw:*

#5 x 5/8" flat head

3000 pcs/master

Length 1-3/16"
Width 7/8"

Brackets

Angled Corner Braces



1-3/8" x 1-3/8"
x 3/4"



1" x 1" x 1/2"



1-1/2" x 1-1/2"
x 1/2"



2" x 2" x 5/8"



2-1/2" x 2-1/2"
x 5/8"



3" x 3" x 3/4"



4" x 4" x 3/4"

Hole Center-to-Center	3/4"	1"	1-9/16"	1-13/16"	2-13/16"		
Antique Copper	1965AC						
Bright Nickel	1965BN						
Polished Brass	9211PB	9212PB					
Zinc	9211	9212	9213	9214	9215	9217	
Recommended screw:	#8 flat head	#6 or #8 flat head	#6 or #8 flat head	#6 or #8 flat head	#6 or #8 flat head	#6 or #8 flat head	
	1000 pcs/ctn	500 pcs/ctn	500 pcs/ctn	500 pcs/ctn	500 pcs/ctn	250 pcs/ctn	250 pcs/ctn



3/4" x 3/4" x 2"

Hole Center-to-Center	32 mm
Black Plated	9013
Bright Nickel	9015
Plain Steel	9011
Zinc	9012
Recommended screw:	#6 pan head

1000 pcs/ctn

Brackets

Flat Mending Plates



2" x 5/8"



2-3/16" x 5/8"



3" x 3/4"



4" x 7/8"



2" x 1-9/16"

Hole Center-to-Center	32 mm	32 mm staggered 2 sets	1-5/8" staggered 2 sets	2-3/8" staggered 2 sets	32 mm horizontal slotted 32 mm vertical slotted
Bright Nickel					9005BN
Zinc	9313	9314	9315	9317	
Recommended screw:	#6 or #8 flat head	#6 or #8 flat head	#6 or #8 flat head	#6 or #8 flat head	#5 pan head
	500 pcs/ctn	500 pcs/ctn	500 pcs/ctn	500 pcs/ctn	500 pcs/ctn

Drawer Adjustment



"Figure 8"
Drawer Front
Connecting
Plate with
Slotted
Adjustment



"Figure 8"
Drawer Front
Connecting
Plate



90° Drawer
Bracket



90° Drawer Bracket
Cover (Plastic)



Euro Bracket

Dimensions	1-11/16"	1-5/16"	2" x 1" x 5/8"	2-1/8" x 1" x 1/2"	42 mm x 47 mm x 23 mm
Hole Center-to-Center	15/16"	5/8"	11/16" horizontal slotted 11/16" vertical slotted		32 mm center-to-center with 16 mm spacing
Beige				1996	
Black Plated					430BLK
Bright Nickel	103559BN	103841BN	9453007		
Zinc					430ZN
Recommended screw:	#6 flat head	#6 flat head	#6 pan head		#6 or #8 flat head or Euro screw
	1000 pcs/ctn	1000 pcs/ctn	1000 pcs/ctn	2000 pcs/ctn	1000 pcs/ctn

Brackets

Plastic

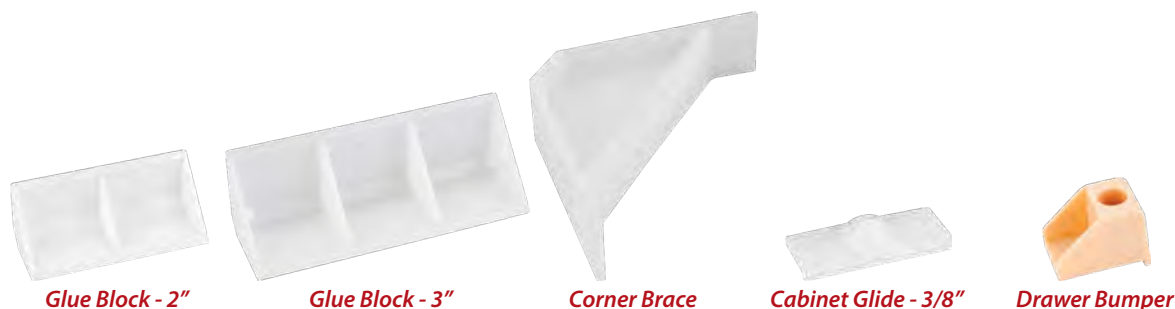

	Glue Block - 2"	Glue Block - 3"	Corner Brace	Cabinet Glide - 3/8"	Drawer Bumper
Dimensions	2" Overall Length 1" Outside Width 5/16" Inside Width	3" Overall Length 1-3/8" Outside Width 1/4" Inside Width	2-5/8" x 2-5/8" 3/4" Height Without Tabs	1-3/4" x 3/4" 3/8" Height	11/16" (18 mm)
Beige	T480-00				B-400-02
Natural			HR410	GLIDE-02	
White	T480-02	T475			
Recommended screw:					#6 pan head
	5000 pcs/ctn	1800 pcs/ctn	1000 pcs/ctn	5000 pcs/ctn	100 pcs/pk 10 pks/ctn

Mirror Hanging & Glass Insert Brackets



	Mirror Hanging Bracket	Mirror Clip	Glass Retainer Clip
Dimensions	Clip - 5/8" x 5/8" Bracket - 1-1/8" x 3/8" Mounting Holes are 1/2" Center-to-Center	3/4" x 5/8" Mounting Screw Preassembled	1-1/8" Overall Height 3/4" Adjustment Screw Included
Antique Copper			9454003
Clear		T220-01-A	
Zinc	MH1625		
Recommended screw:	#6 pan head		#6 pan head
	5000 pcs/ctn	2500 pcs/ctn	2500 pcs/ctn

Commercial Hardware

We have a broad selection of products for commercial applications that includes hinges and slides, standards and brackets, shelf supports, locks and more.

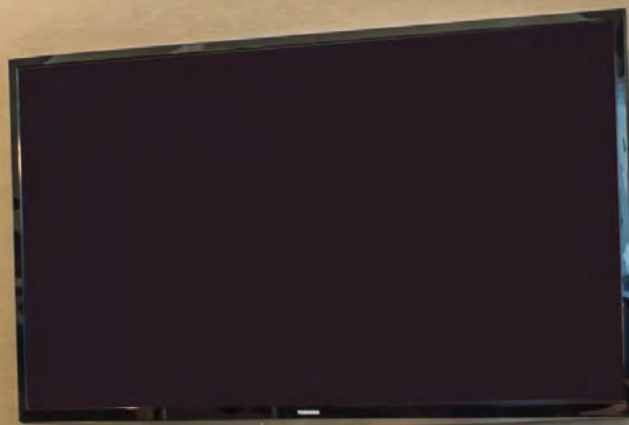

800.463.0660
www.HardwareResources.com

hardware
resources[®]

Institutional Hinges

5 Knuckle Overlay Hinge

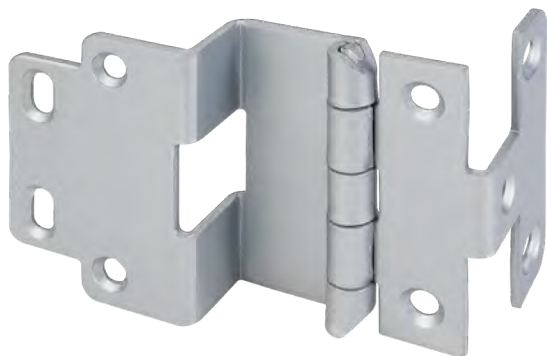

Bulk Pack

Almond Powder Coat	HR0076AL
Black Powder Coat	HR0076BLK
Dull Chrome (26D)	HR0076
Polished Brass	HR0076PB
Stainless Steel (304)	HR0076SS
White Powder Coat	HR0076WH
Recommended screw:	#8 flat head or Euro

108 pcs/box

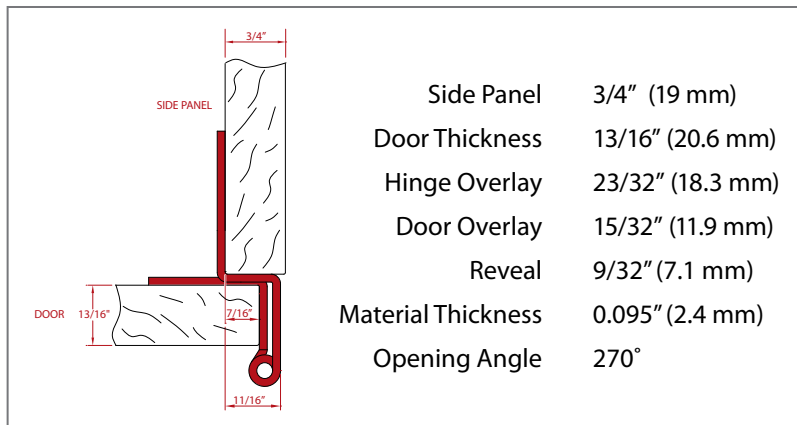

Side Panel	3/4" (19 mm)
Door Thickness	13/16" (20.6 mm)
Hinge Overlay	23/32" (18.3 mm)
Door Overlay	15/32" (11.9 mm)
Reveal	9/32" (7.1 mm)
Material Thickness	0.095" (2.4 mm)
Opening Angle	270°

- » Conforms to ANSI/BHMA Grade 1 Requirements
- » Hospital tips, 2-3/4" overall height
- » Drilled knuckle inner diameter
- » 32 mm system hole pattern with 37 mm setback
- » Countersunk screw holes for recommended #8 flat head or Euro screws
- » Slotted screw holes for vertical and horizontal adjustment
- » Stainless steel #8 x 3/4" flathead screw available (8X347-2)

Single Pivot Hinge



Bulk Pack

Nickel	HR0086
Recommended screw:	#8 pan head

100 pcs/ctn

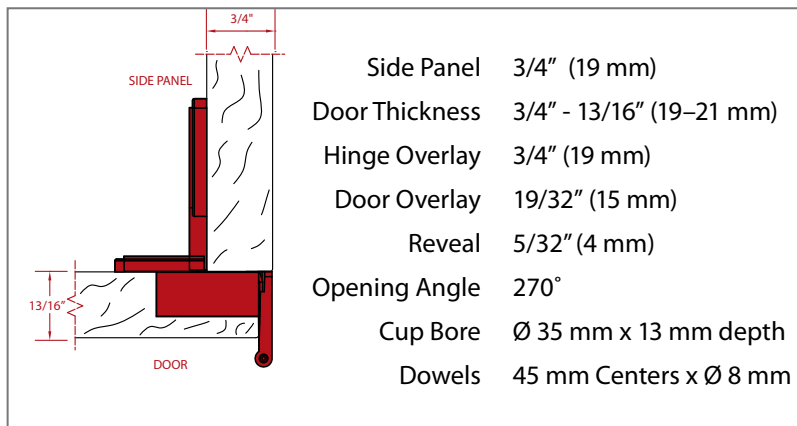

Side Panel	3/4" (19 mm)
Door Thickness	3/4" - 13/16" (19-21 mm)
Hinge Overlay	3/4" (19 mm)
Door Overlay	19/32" (15 mm)
Reveal	5/32" (4 mm)
Opening Angle	270°
Cup Bore	Ø 35 mm x 13 mm depth
Dowels	45 mm Centers x Ø 8 mm

- » Solid zinc die cast construction
- » For full overlay applications – 2 dimensional adjustment
- » Hinge and plate ship pre-assembled
- » Cup ships with 8 mm dowels
- » Integrated polymer catch with positive lock
- » Conforms to ANSI/BHMA Grade 1 Requirements

Medium Duty Standards & Brackets

TRK03 Series



- » 800 lb. per pair
- » Single slot design
- » Steel with zinc plating
- » Adjustable in 1" increments
- » 3/4" x 1/2" x length (below)
- » ANSI/BHMA A156.9-2003



Ordering

Length	Thickness	Zinc Track
24"	16-gauge	TRK03-24
36"	16-gauge	TRK03-36
48"	16-gauge	TRK03-48
60"	16-gauge	TRK03-60
72"	16-gauge	TRK03-72
84"	16-gauge	TRK03-84
96"	16-gauge	TRK03-96

10 pcs/ctn

Medium Duty Standards & Brackets

Part No.	A
TRK03-24	24"
TRK03-36	36"
TRK03-48	48"
TRK03-60	60"
TRK03-72	72"
TRK03-84	84"
TRK03-96	96"

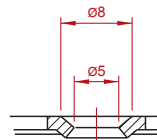
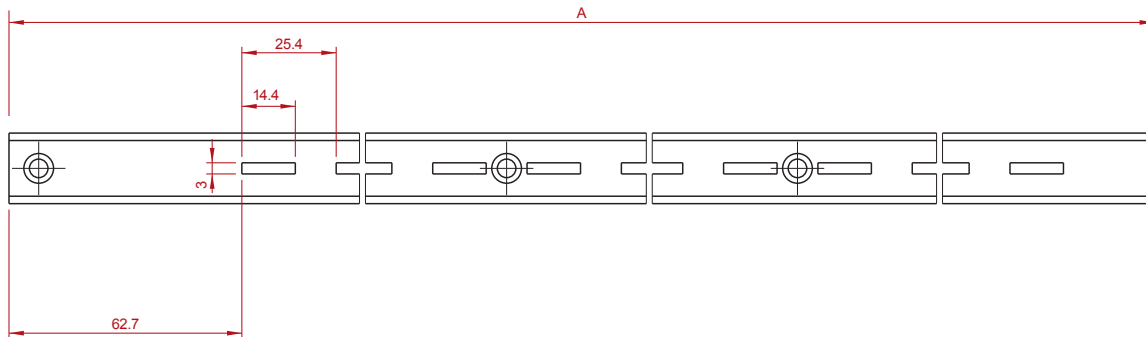
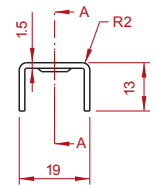
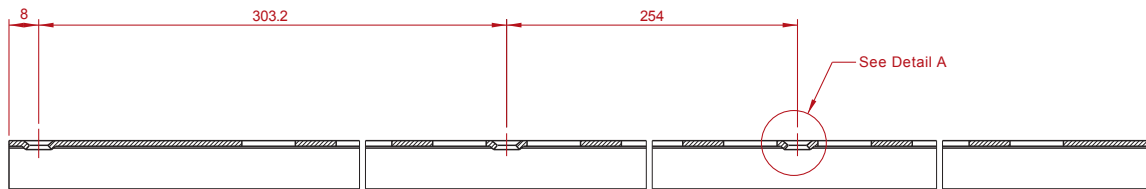

Detail A
Scale 3:2

NOTE: Proper installation and mounting required. Tested to meet or exceed ANSI/BHMA performance standards. Weight limits are based on standards mounted on 16" centers utilizing all provided fastener holes. Mounting fasteners must individually provide at least 650 lb. tensile pullout and 900 lb. shear strength.

Medium Duty Standards & Brackets

TRK03 Series

Commercial
Hardware



- » 210 lb. per shelf
- » Flanges include keyhole mounting holes
- » Center flanged brackets are used to join two shelves
- » Steel with zinc plating
- » ANSI/BHMA A156.9-2003

Ordering

Length	Thickness	Left Bracket	Right Bracket	Center Bracket
8"	14-gauge	3460-8L	3460-8R	3460-8C
10"	14-gauge	3460-10L	3460-10R	3460-10C
12"	14-gauge	3460-12L	3460-12R	3460-12C
14"	14-gauge	3460-14L	3460-14R	3460-14C
16"	14-gauge	3460-16L	3460-16R	3460-16C
18"	14-gauge	3460-18L	3460-18R	3460-18C
20"	14-gauge	3460-20L	3460-20R	3460-20C

10 pcs/ctn 10 pcs/ctn 10 pcs/ctn

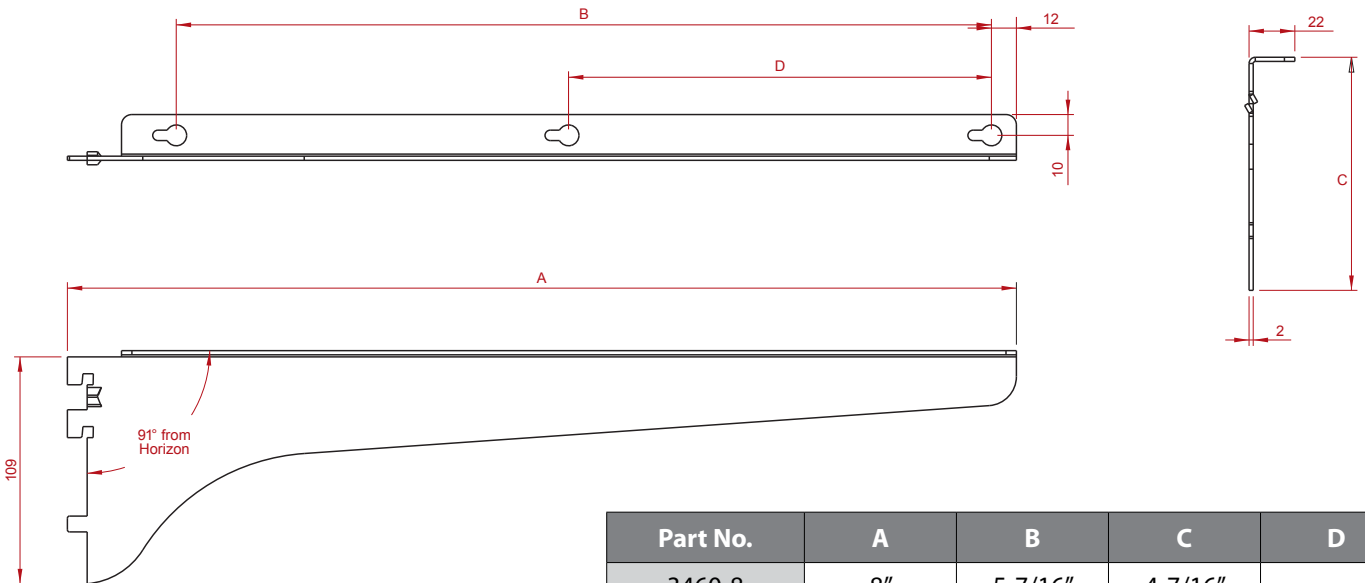

Part No.	A	B	C	D
3460-8	8"	5-7/16"	4-7/16"	
3460-10	10"	7-7/16"	4-7/16"	
3460-12	12"	9-7/16"	4-7/16"	
3460-14	14"	11-7/16"	4-7/16"	6"
3460-16	16"	13-7/16"	4-7/16"	7"
3460-18	18"	15-7/16"	4-7/16"	8"
3460-20	20"	17-7/16"	4-7/16"	9"

NOTE: Proper installation and mounting required. Tested to meet or exceed ANSI/BHMA performance standards. Weight limits are based on standards mounted on 16" centers utilizing all provided fastener holes. Mounting fasteners must individually provide at least 650 lb. tensile pullout and 900 lb. shear strength.

Heavy Duty Standards & Brackets

TRK05 Series

- » 1000 lb. per pair
- » Double slot design
- » Steel with zinc plating or white powder coating
- » Adjustable in 1" increments
- » 1-1/4" x 1/2" x length (below)
- » ANSI/BHMA A156.9-2003



Heavy Duty Standards & Brackets

Ordering

Length	Thickness	Zinc Track	White Track
24"	16-gauge	TRK05-24	TRK05-24WH
36"	16-gauge	TRK05-36	TRK05-36WH
48"	16-gauge	TRK05-48	TRK05-48WH
60"	16-gauge	TRK05-60	TRK05-60WH
72"	16-gauge	TRK05-72	TRK05-72WH
84"	16-gauge	TRK05-84	TRK05-84WH
96"	16-gauge	TRK05-96	TRK05-96WH

10 pcs/ctn 10 pcs/ctn

Part No.	A
TRK05-24	24"
TRK05-36	36"
TRK05-48	48"
TRK05-60	60"
TRK05-72	72"
TRK05-84	84"
TRK05-96	96"

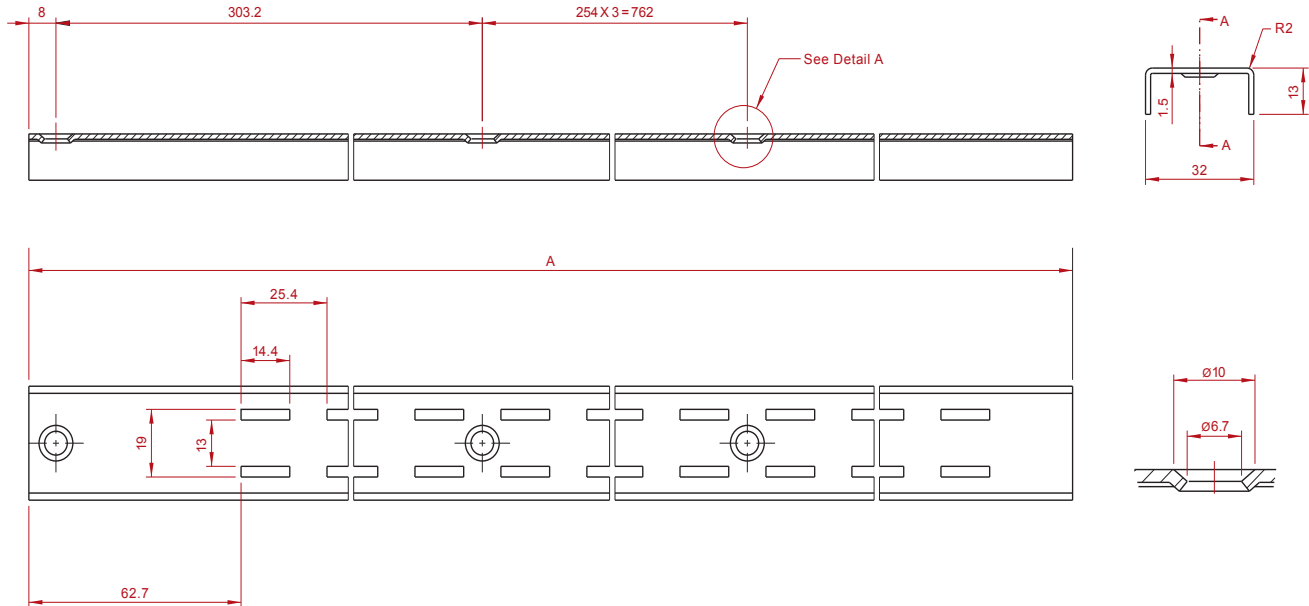

NOTE: Proper installation and mounting required. Tested to meet or exceed ANSI/BHMA performance standards. Weight limits are based on standards mounted on 16" centers utilizing all provided fastener holes. Mounting fasteners must individually provide at least 650 lb. tensile pullout and 900 lb. shear strength.

Heavy Duty Standards & Brackets TRK05 Series

Commercial
Hardware



- » 180 lb. per shelf (8"-14"), 210 lb. per shelf (16"-24")
- » Double-lug brackets provide strong weight-bearing support
- » Steel with zinc plating
- » ANSI/BHMA A156.9-2003

Ordering

Length	Thickness	Zinc Bracket	White Bracket
8"	16-gauge	5460-8	5460-8WH
10"	16-gauge	5460-10	5460-10WH
12"	16-gauge	5460-12	5460-12WH
14"	16-gauge	5460-14	5460-14WH
16"	16-gauge	5460-16	5460-16WH
18"	16-gauge	5460-18	5460-18WH
20"	16-gauge	5460-20	5460-20WH
22"	16-gauge	5460-22	5460-22WH
24"	16-gauge	5460-24	5460-24WH

10 pcs/ctn

10 pcs/ctn

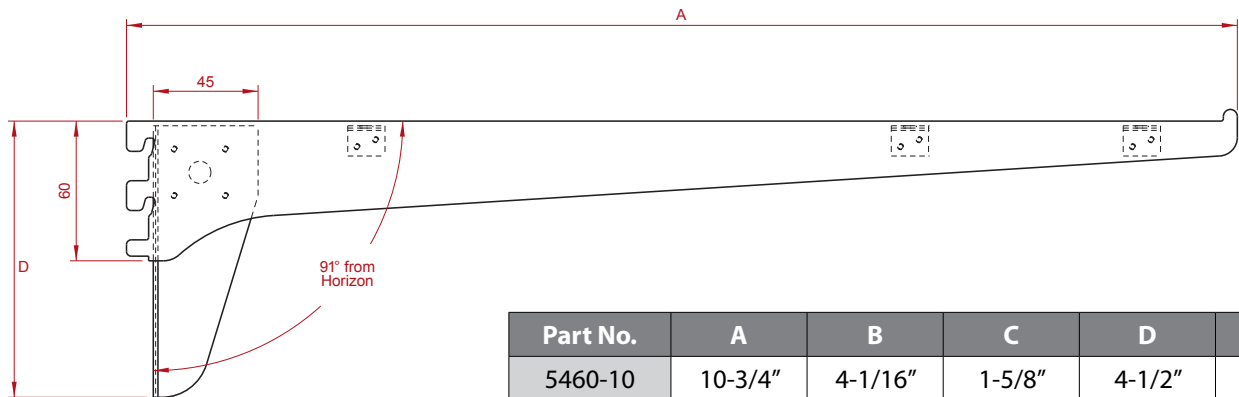
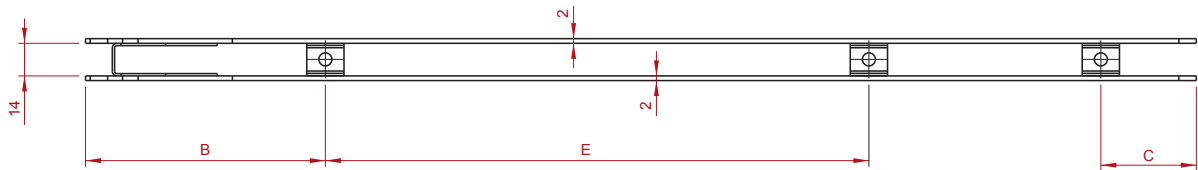

Part No.	A	B	C	D	E
5460-10	10-3/4"	4-1/16"	1-5/8"	4-1/2"	
5460-12	12-3/4"	4-1/16"	1-5/8"	4-1/2"	
5460-14	14-3/4"	4-1/16"	1-5/8"	4-1/2"	
5460-16	16-3/4"	4-1/16"	1-5/8"	4-1/2"	
5460-18	18-3/4"	4-1/16"	1-5/8"	4-1/2"	9-3/16"
5460-20	20-3/4"	4-1/16"	1-5/8"	4-1/2"	11-3/16"
5460-22	22-3/4"	4-1/16"	1-5/8"	4-1/2"	13-3/16"
5460-24	24-3/4"	4-1/16"	1-5/8"	4-1/2"	13-3/16"

NOTE: Proper installation and mounting required. Tested to meet or exceed ANSI/BHMA performance standards. Weight limits are based on standards mounted on 16" centers utilizing all provided fastener holes. Mounting fasteners must individually provide at least 650 lb. tensile pullout and 900 lb. shear strength.

Extra Heavy Duty Standards & Brackets TRK07 Series



- » 1800 lb. per pair
- » Single slot design
- » Steel with zinc plating
- » Adjustable in 2" increments
- » Plastic lock secures bracket to track
- » 7/8" x 11/16" x length (below)
- » ANSI/BHMA A156.9-2003



Ordering

Length	Thickness	Zinc Track
24"	12-gauge	TRK07-24
36"	12-gauge	TRK07-36
48"	12-gauge	TRK07-48
60"	12-gauge	TRK07-60
72"	12-gauge	TRK07-72
84"	12-gauge	TRK07-84
96"	12-gauge	TRK07-96

10 pcs/ctn

Extra Heavy Duty Standards & Brackets

Part No.	A	B	C	D	E
TRK07-24	23.75"	11	22"	1	12"
TRK07-36	35.75"	17	34"	2	24"
TRK07-48	47.75"	23	46"	3	36"
TRK07-60	59.75"	29	58"	4	48"
TRK07-72	71.75"	35	70"	5	60"
TRK07-84	83.75"	41	82"	6	72"
TRK07-96	95.75"	47	94"	7	84"

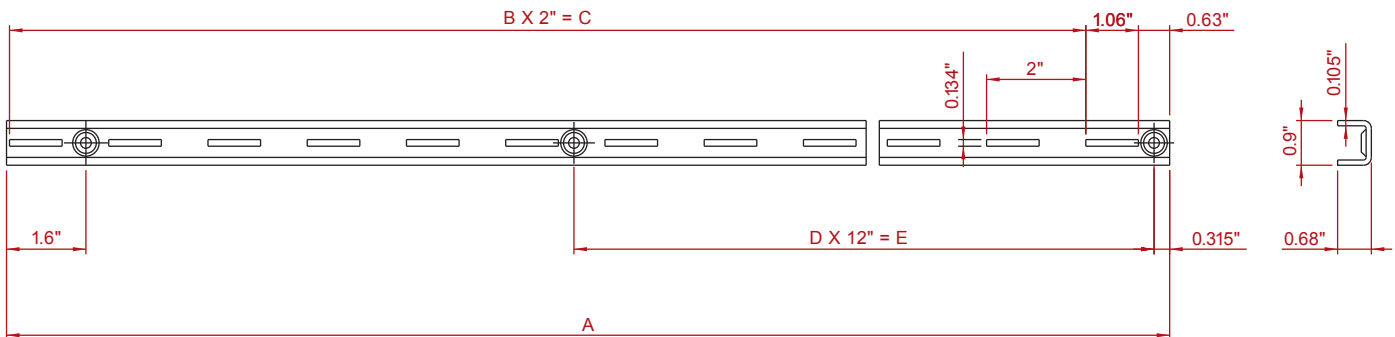

NOTE: Proper installation and mounting required. Tested to meet or exceed ANSI/BHMA performance standards. Weight limits are based on standards mounted on 16" centers utilizing all provided fastener holes. Mounting fasteners must individually provide at least 650 lb. tensile pullout and 900 lb. shear strength.

Extra Heavy Duty Standards & Brackets TRK07 Series

Commercial
Hardware

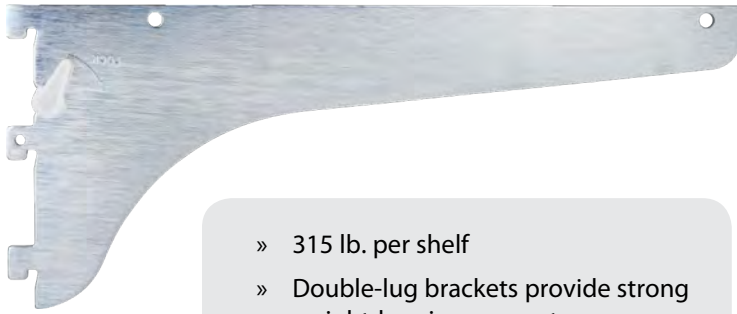

- » 315 lb. per shelf
- » Double-lug brackets provide strong weight-bearing support
- » Steel with zinc plating
- » ANSI/BHMA A156.9-2003

Ordering

Length	Thickness	Zinc Bracket
12"	12-gauge	7460-12
14"	12-gauge	7460-14
16"	12-gauge	7460-16
18"	12-gauge	7460-18
20"	12-gauge	7460-20
22"	12-gauge	7460-22
24"	12-gauge	7460-24

10 pcs/ctn

Part No.	A	B
7460-12	12"	9"
7460-14	14"	11"
7460-16	16"	13"
7460-18	18"	15"
7460-20	20"	17"
7460-22	22"	19"
7460-24	24"	21"

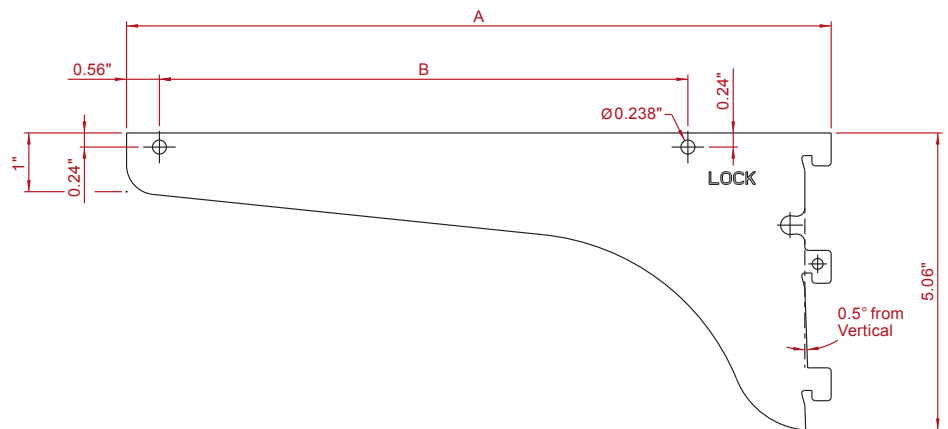

Center Rest	End Rest	Front Rest
		
7460-CR 1000 bags/ctn	7460-ER 1000 bags/ctn	7460-FR 1000 bags/ctn

Polybagged with one rest and one attachment screw.

Polybagged with one rest and one attachment screw.

Polybagged with one rest and one attachment screw.

- » For use with 7460 Series Extra Heavy Duty Standards
- » Works with any size 7460 series shelf bracket
- » Steel with zinc plating

NOTE: Proper installation and mounting required. Tested to meet or exceed ANSI/BHMA performance standards. Weight limits are based on standards mounted on 16" centers utilizing all provided fastener holes. Mounting fasteners must individually provide at least 650 lb. tensile pullout and 900 lb. shear strength.

Work Station Brackets

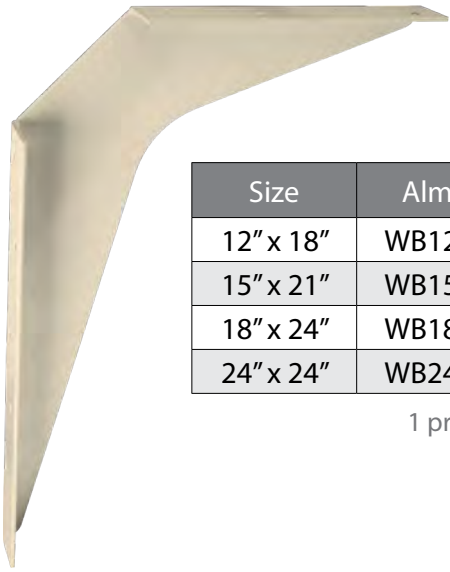

Size	Almond
12" x 18"	WB12-ALD
15" x 21"	WB15-ALD
18" x 24"	WB18-ALD
24" x 24"	WB24-ALD

1 pr/ctn

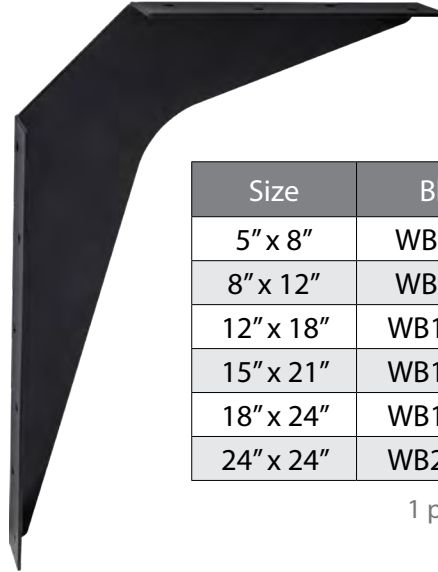

Size	Black
5" x 8"	WB5-BLK
8" x 12"	WB8-BLK
12" x 18"	WB12-BLK
15" x 21"	WB15-BLK
18" x 24"	WB18-BLK
24" x 24"	WB24-BLK

1 pr/ctn



Size	Primer
12" x 18"	WB12-PR
15" x 21"	WB15-PR
18" x 24"	WB18-PR
24" x 24"	WB24-PR

1 pr/ctn

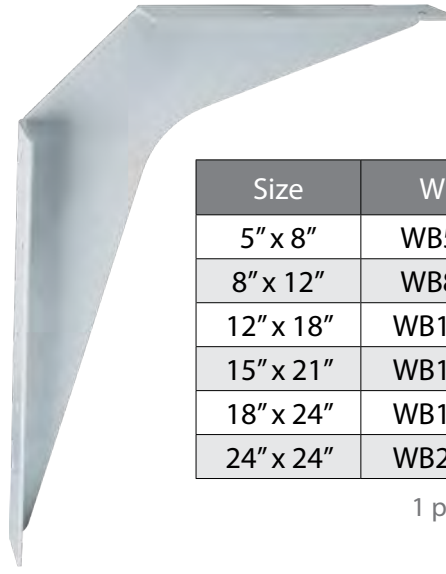

Size	White
5" x 8"	WB5-WH
8" x 12"	WB8-WH
12" x 18"	WB12-WH
15" x 21"	WB15-WH
18" x 24"	WB18-WH
24" x 24"	WB24-WH

1 pr/ctn

Recommended screw: #8 pan washer head

- » Rear cutout for cable management
- » Sold per pair, left and right
- » Reversible to accommodate two different countertop depths
- » WB12, WB15, WB18 & WB21 rated for 1000 lb. per pair load capacity
- » WB5 rated for 300 lb. per pair & WB8 rated for 375 lb. per pair
- » Steel construction
- » ANSI/BHMA A156.9-2003

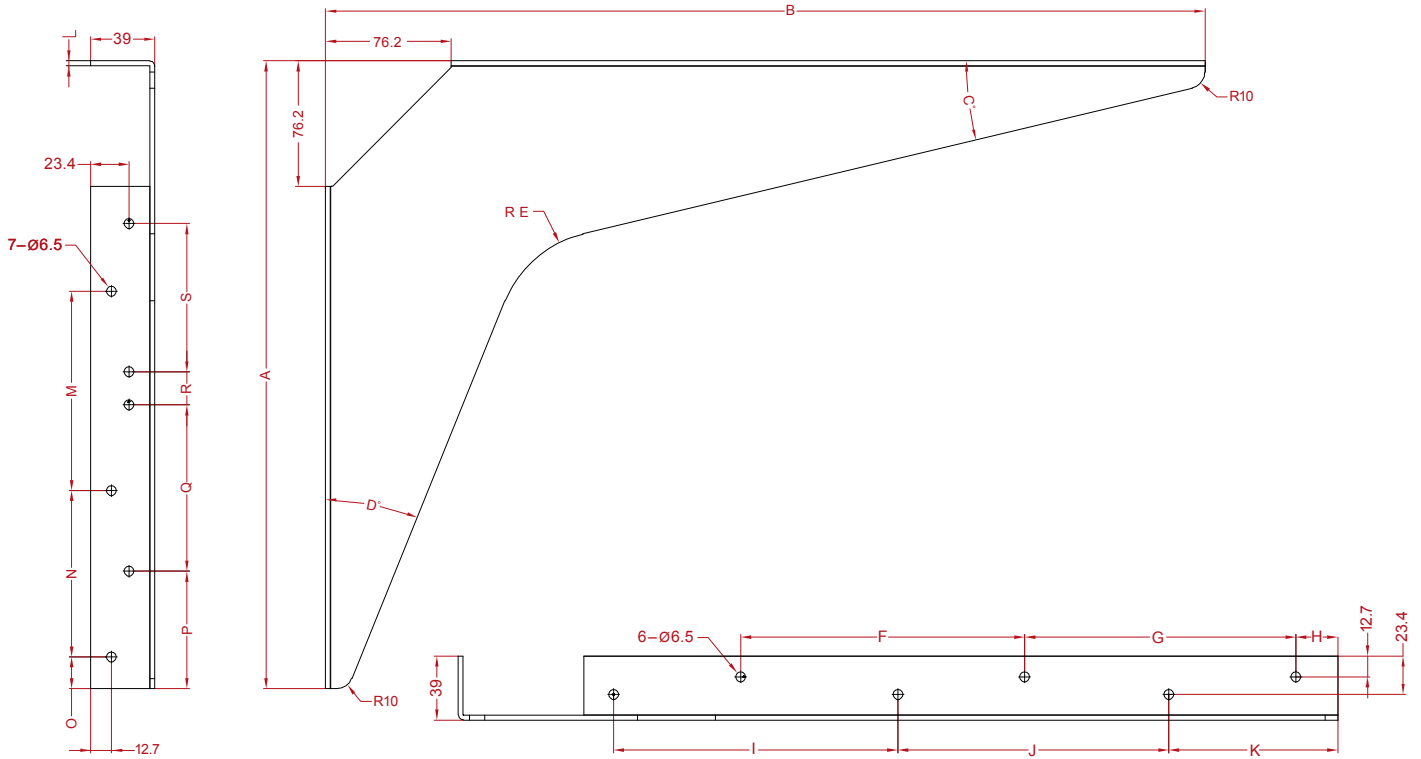

Part No.	A	B	C	D	E	F	G	H	I	J	K	L	M	N	O	P	Q	R	S
5" x 8"	200	125	23°	13°	50	-	50	15	-	50	40	2	-	94	20	67	94	-	-
8" x 12"	200	300	13°	25°	65	-	150	25	-	150	100	2	-	94	29	67	94	-	-
12" x 18"	298.5	450.9	12.8°	19.5°	65	140	130	25	139.7	130	87	3	-	120	20	80	119.7	-	-
15" x 21"	381	533.3	13.5°	22°	68	172.4	164.4	25.4	172.4	164.4	102.4	3	121	101	19.3	71.3	101	20	90
18" x 24"	463	616	11°	16.5°	71	352.5	95	55	231.7	149	32	3	192.5	98.4	54	32.5	158	72	-
24" x 24"	603.3	603.3	11°	11°	68	352.5	95	55	231.7	149	32	3	352.5	95	55	32	149	231.7	-

Cable Grommets



Two Piece with Tab Removed



Three Piece with Adjustable Spring Closure



Three Piece with Adjustable Spring Closure



Plastic Grommet without Cover

Cover Diameter	Ø 61 mm	Ø 71 mm	Ø 3-1/2"	Ø 5-3/4"
Drilling Hole Diameter	Ø 1-7/8" (48 mm)	Ø 2-3/8" (60 mm)	Ø 3" (75 mm)	Ø 5" (127 mm)
Height Under Cover	5/8" (16 mm)	25/32" (20 mm)	25/32" (20 mm)	1" (25 mm)
Black	63000 500 pcs/ctn	68000BK 500 pcs/ctn	69000BK 500 pcs/ctn	
Brown		68000BR 500 pcs/ctn		
Grey		68000GR 500 pcs/ctn		
White		68000WH 500 pcs/ctn	69000WH 500 pcs/ctn	67000WH 200 pcs/ctn

63000

68000

69000

67000WH

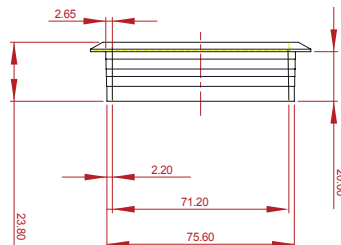
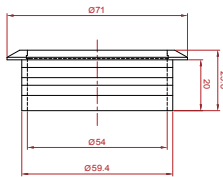
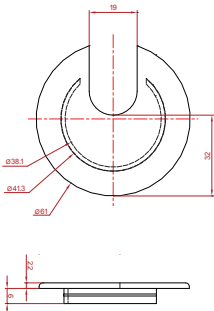
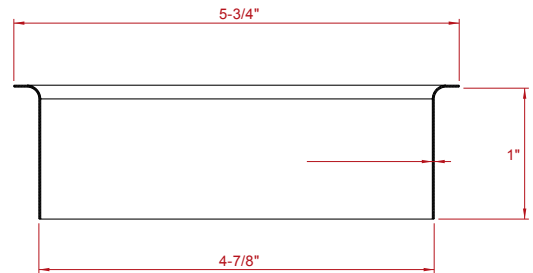
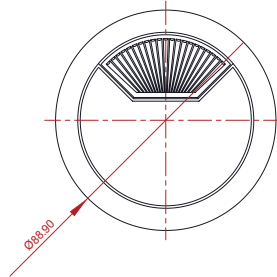
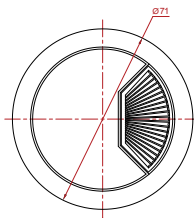
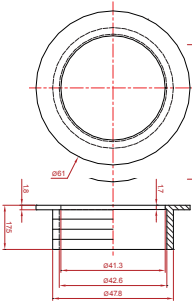

Trash Can Grommets

Commercial
Hardware



	6"	8"	10"	12"
Grommet Diameter	Ø 6-5/8" (169 mm)	Ø 8-5/8" (219 mm)	Ø 10-5/8" (269 mm)	Ø 12-9/16" (319 mm)
Drilling Hole Diameter	Ø 5-15/16" (152 mm)	Ø 7-15/16" (202 mm)	Ø 9-15/16" (253 mm)	Ø 11-15/16" (303 mm)
Height	2" (50.8 mm)	2" (50.8 mm)	2" (50.8 mm)	2" (50.8 mm)
Stainless Steel	TCR6-SS 10 pcs/ctn	TCR8-SS 10 pcs/ctn	TCR10-SS 10 pcs/ctn	TCR12-SS 10 pcs/ctn

	6"	8"
Grommet Diameter	Ø 6-5/8" (169 mm)	Ø 8-5/8" (219 mm)
Drilling Hole Diameter	Ø 5-15/16" (152 mm)	Ø 7-15/16" (202 mm)
Height	6" (152.4 mm)	6" (152.4 mm)
Stainless Steel	TCR66-SS 6 pcs/ctn	TCR86-SS 6 pcs/ctn

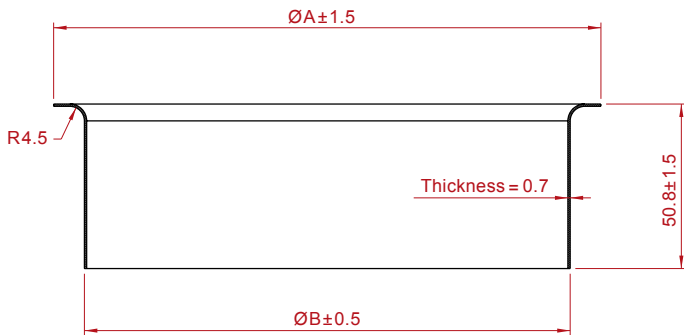

Part No.	A	B
TCR6-SS	169	150
TCR8-SS	219	200
TCR10-SS	269	251
TCR12-SS	319	301

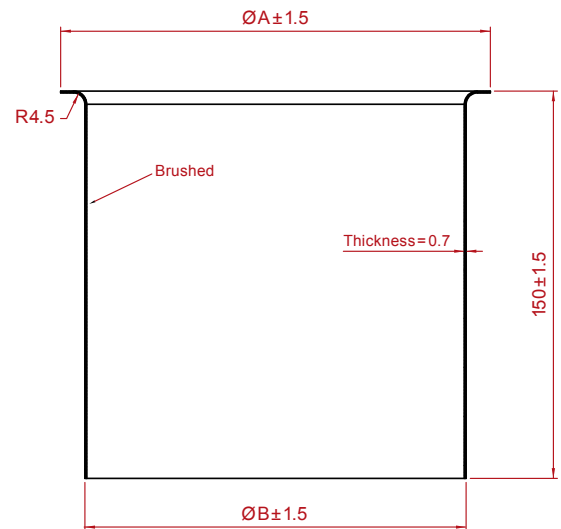

Part No.	A	B
TCR66-SS	169	150
TCR86-SS	219	200

Two Piece Panel Connectors

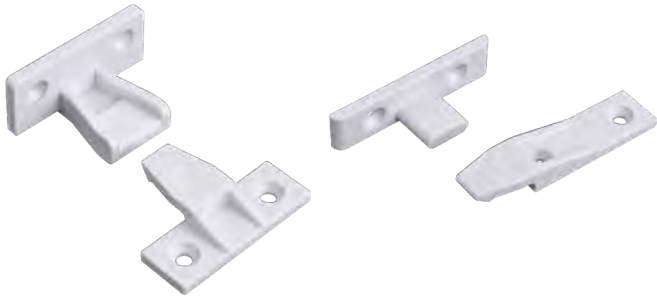

Push-in Fastener

Suspension Fittings

White plastic

200-K1
sold by pair

200-K2
sold by pair

*Recommended
screw:*

#7 flat head

#7 flat head



*1-3/8" x 2" Panel Clips
32 mm CC Holes*

*96" Panel Clip Bar
8" CC Holes*

Zinc

200-ZB
200 pcs/ctn

200-Z96
25 pcs/ctn

*Recommended
screw:*

#7 pan washer head

- » Push-in fastener for fastening panels to frames
- » Suspension fittings for securing trim and panels directly to walls without wood subframe. Frame can be preassembled. Panels are hung on site.

- » Mount panels or cabinets to the wall
- » Fast and easy mounting and removal
- » Clips securely grab each other
- » Clips are concealed when mounted
- » Aluminum construction
- » 8' stick with holes indexed for 16" or 24" studs

200-K1 Base

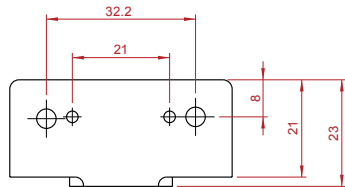

200-K2 Base

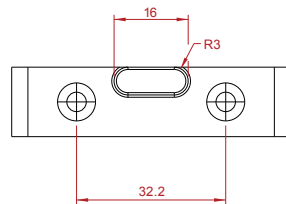

200-K1 Locker

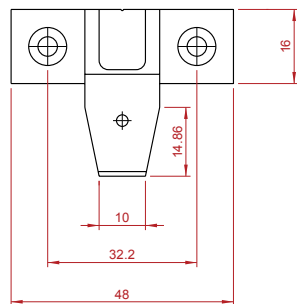

200-K2 Locker

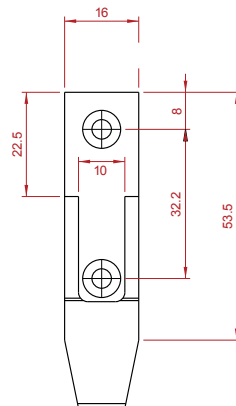

200-ZB

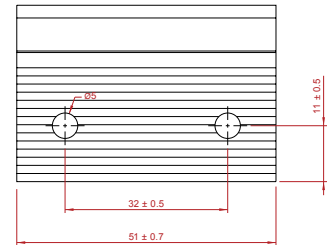
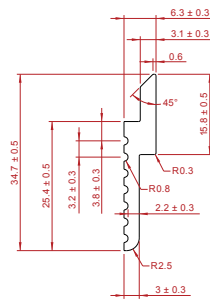

200-Z96

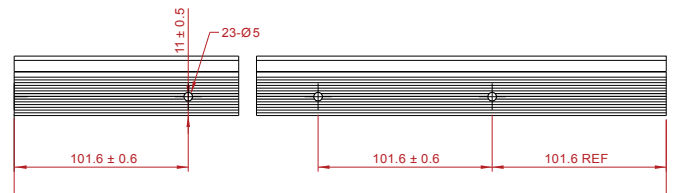

Connectors

Two Piece Connector Bolt



2 Piece Connector Bolt

Ø 5 mm Drilling 35–45 mm Panel	565NP35-B 600 pcs/ctn
Ø 8 mm Drilling 31–41 mm Panel	555NP31-B 400 pcs/ctn

- » Designed for joining two panels
- » Pozi drive allows for maximum torque in a hand or machine-driven application
- » Ø 5 mm or Ø 8 mm pilot holes are required
- » Nickel plated
- » White box packed
- » Salt Anti-corrosion Certified ANSI/BHMA A156.9-2010

Confirmat Flat Head Screws



7 mm x 50 mm

Blunt Tip	HR7X50-B 500 pcs/ctn
Pointed Tip	HR7X50P-B 500 pcs/ctn

- » Pozi drive allows for maximum torque in hand or machine-driven applications
- » Coarse thread yields maximum engagement into a variety of materials
- » White box packed

Catches

Roller Catch



Roller Catch

Zinc

RC02-ZN
1000 pcs/ctn

Recommended screw:

screws included

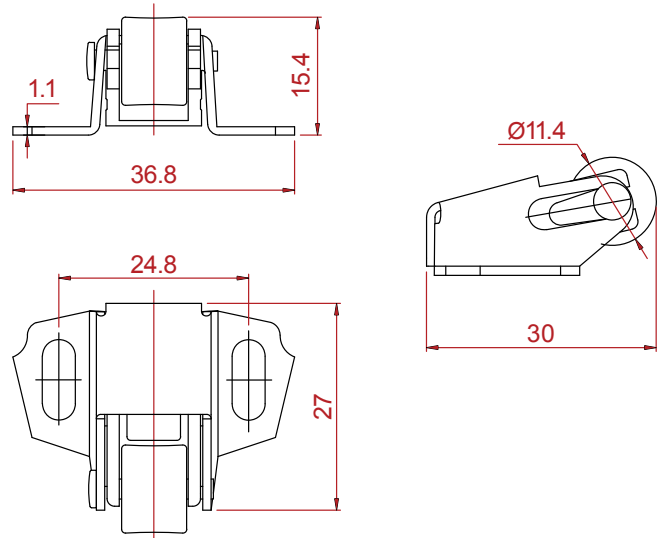

Magnetic Catch



**Magnetic Catch
8 lb.**

Zinc

50760
250 pcs/ctn

Recommended screw:

screws included

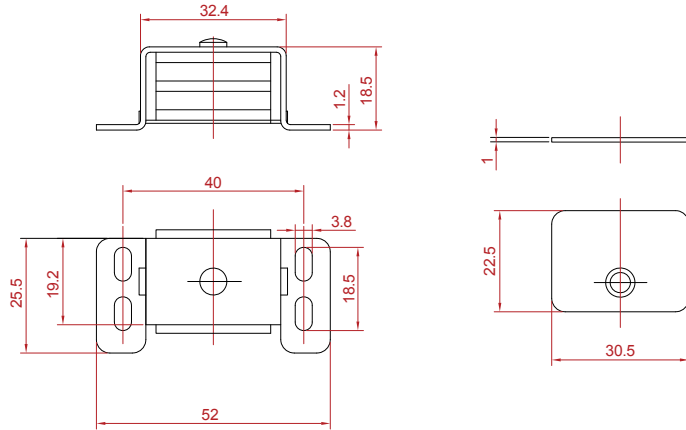

Elbow Catch



Elbow Catch

Nickel

EC02-NI
400 pcs/ctn

Recommended screw:

#5 flat head for catch
#6 pan head for strike plate

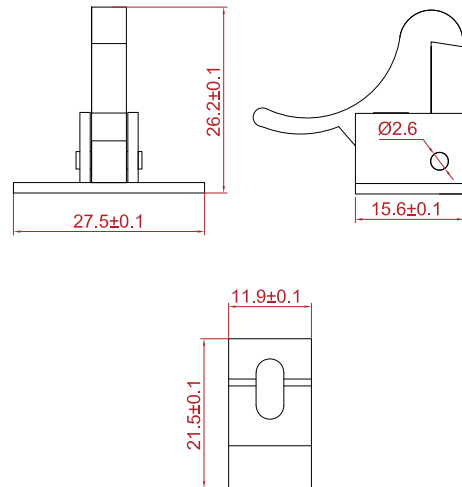

Magnetic Touch Latch



Magnetic Touch Latch



Black

506L2
600 pcs/ctn



White

506L1
600 pcs/ctn

Recommended screw:

#6 x 3/4" pan head

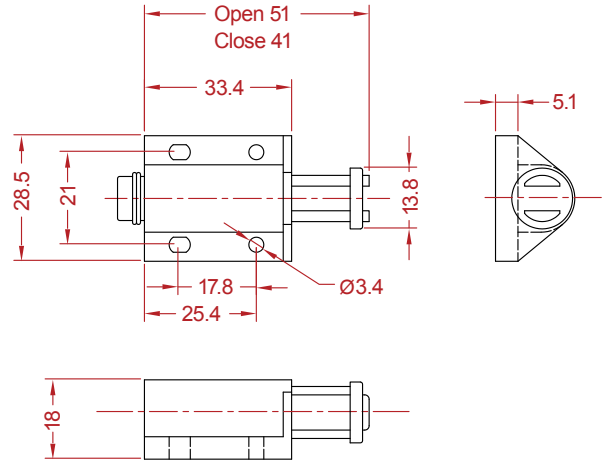

Strike Plates



1-3/16" x 7/8"



Bronze

506S2
3000 pcs/ctn



White

506S4
3000 pcs/ctn



Zinc

506S1
500 pcs/box
3000 pcs/master

Recommended screw:

#5 x 5/8" flat head

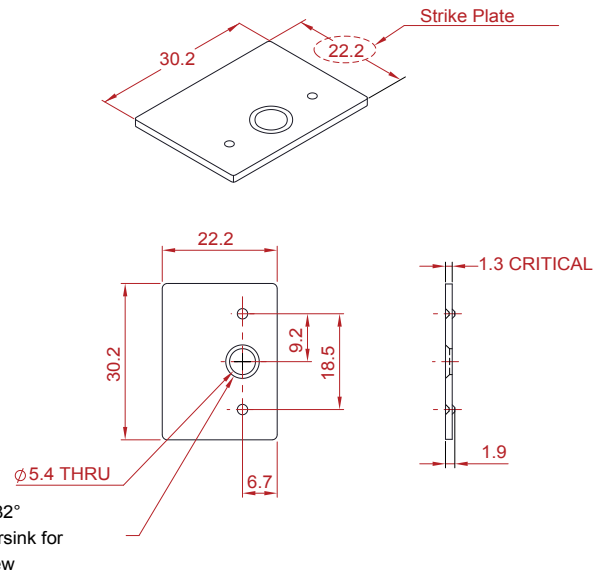

7/8" Zinc Die Cast Drawer Lock

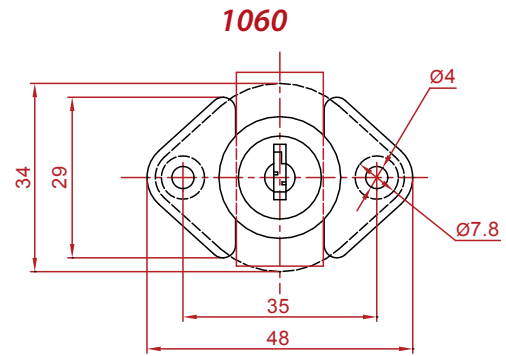

7/8" Zinc Die Cast Drawer Lock

Brass Keyed Alike	1060BR
Chrome Keyed Different	1060CH

1 pc/bag
250 pcs/ctn

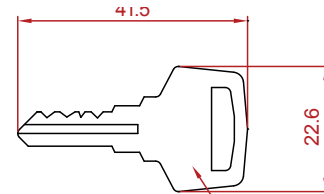
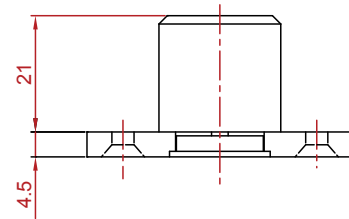

2 PCS Plating: BN

- » Standard 7/8" (22 mm) length with straight cam
- » Screws mount on 35 mm center
- » 180° angle of rotation
- » 2 keys included per bag
- » Master keying not available

Strike Plate for Cam Locks



7000201

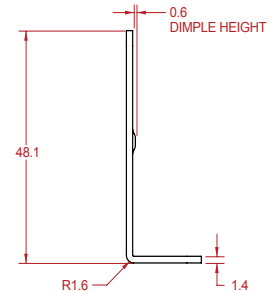
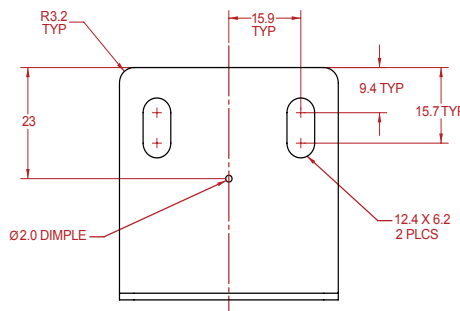

Bright Nickel	7000201BN
Recommended screw:	#8 washer head
500 pcs/ctn	

- » Long-lasting steel construction
- » Screw-on mount

Zinc Die Cast Drawer Lock

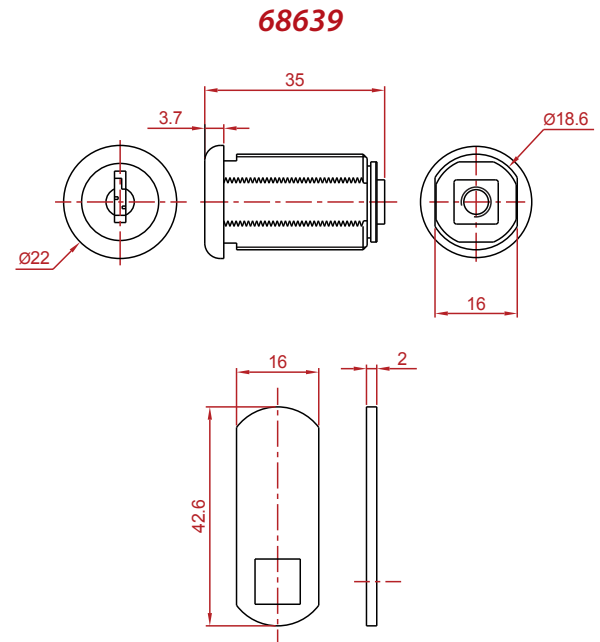

	1-1/8"	1-1/2"
Chrome Keyed Alike	68639CH	78739CH
Chrome Keyed Different	68639CHKD	78739CHKD
	1 pc/bag 200 pcs/ctn	1 pc/bag 200 pcs/ctn

- » Fork cam and 3/8" offset cam for flush applications
- » Body mounts with hex nut and prong washer into 3/4" (19 mm) diameter hole
- » 90° angle of rotation
- » 2 keys included per bag
- » For plastic, metal or wood applications
- » Master keying not available

Shelf Supports

Ø 5 mm Pin Shelf Supports

» Solid steel construction



Spoon

**Spoon with
Anti-Slide Barb**

**Grommet
5.5 mm drill Ø**

**3/4" Arm
With 1/8" Hole**

Antique Brass	1306AB		1283AB	1707AB
Antique Copper	1306AC			1707AC
Black	1306BLK		1283BLK	1707BLK
Bright Nickel	1306BN	1306BN-2	1283BN	1707BN
Polished Brass	1306PB		1283PB	1707PB

1000 pcs/box*
6000 pcs/ctn

1000 pcs/box*
6000 pcs/ctn

1000 pcs/box*
5000 pcs/ctn

1000 pcs/ctn*



***NO BROKEN BOXES. FULL BOXES ONLY.**

FOR A COMPLETE SELECTION OF SHELF PINS SEE PAGES 835-838.

1306

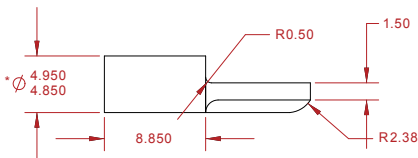

1283

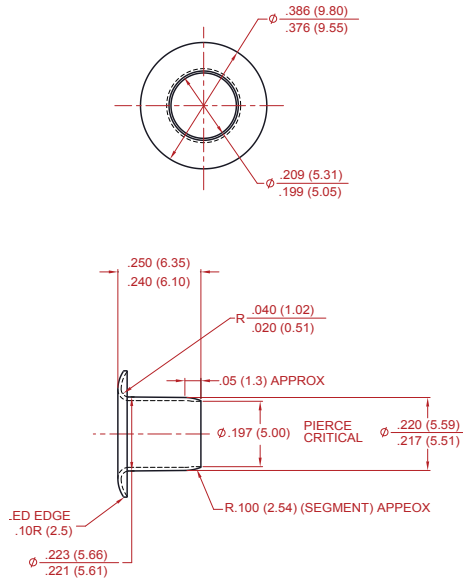

1707

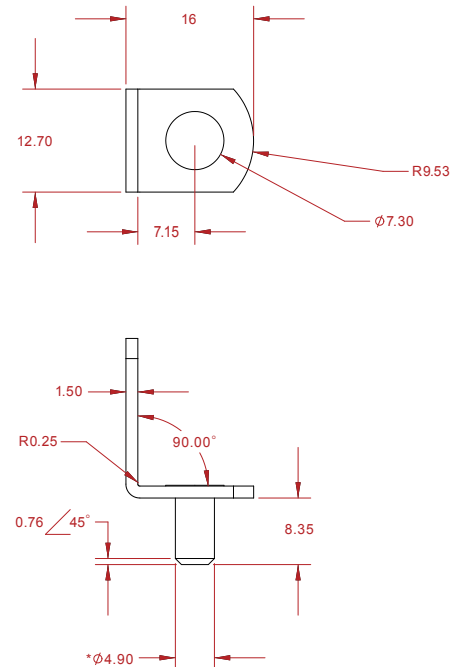

Shelf Supports

Ø 5 mm Pin Shelf Supports



Support with 5 mm Shelf Hold Pin

Zinc	1545ZN
	1000 pcs/ctn

» Solid zinc die cast construction

1545ZN

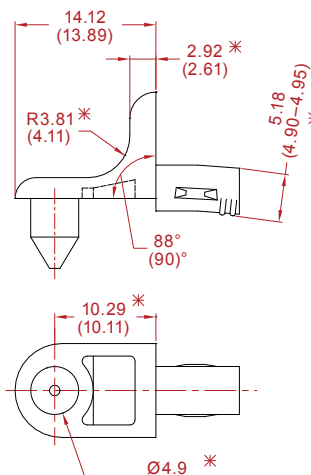

Heavy Duty Shelf Lock



*Ø 5 mm Double Pin
3/4" or 1" Shelf*

Clear	7706CL
	2000 pcs/ctn

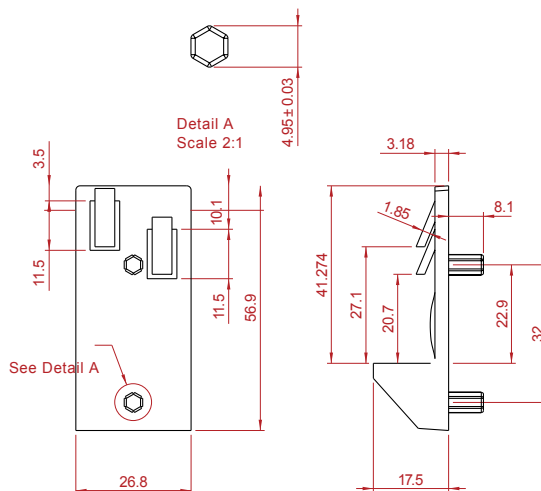

- » 500 lb. weight rating per set of 4
- » Highly durable synthetic plastic construction
- » Fits 3/4" or 1" shelf thickness
- » Two pins are 32 mm spaced
- » ANSI/BHMA A156.9-2003 Grade 1

Adjustable Plastic Foot



- » 850 lb. per set of 4
- » Adjustable 100–170 mm
- » Snap-on toe kick bracket

Plastic Foot

Black

TP03
200 pcs/ctn

Recommended screws:

#7 flat head for cabinet attachment
#7 pan head for toe kick attachment

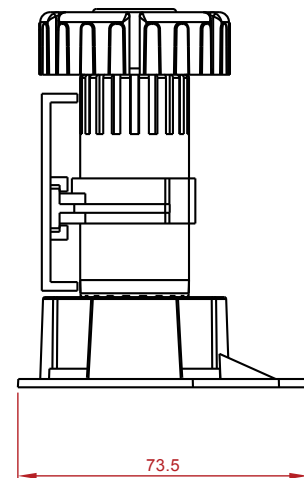
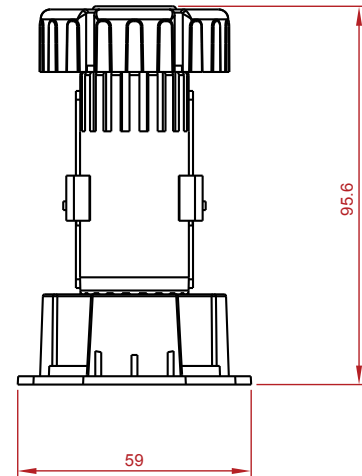
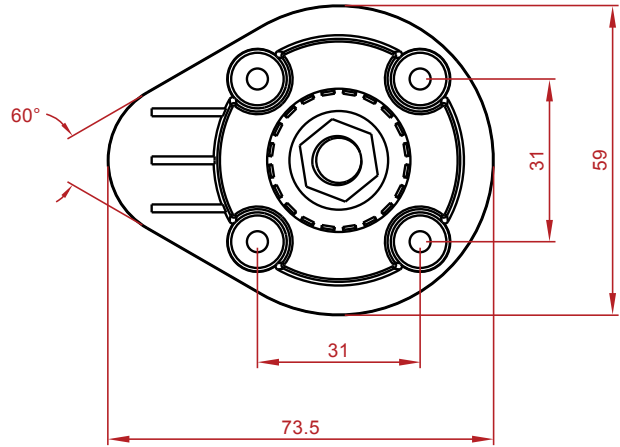

Feet & Legs

Leg Levelers



Leg Levelers

40 mm long x 28.5 mm wide	LL-40 250 pcs/ctn
120 mm long x 28.5 mm wide	LL-120 250 pcs/ctn

- » Non-scratch plastic shoe that is rust-free
- » T-nuts have prongs that provide good grip when hammered into wood
- » Hex nut provides ready height adjustment as the screw threads into T-nut
- » 28.5 mm wide
- » Threaded T-nut included
- » Available in 40 mm and 120 mm sizes
- » Polybagged in sets of 4

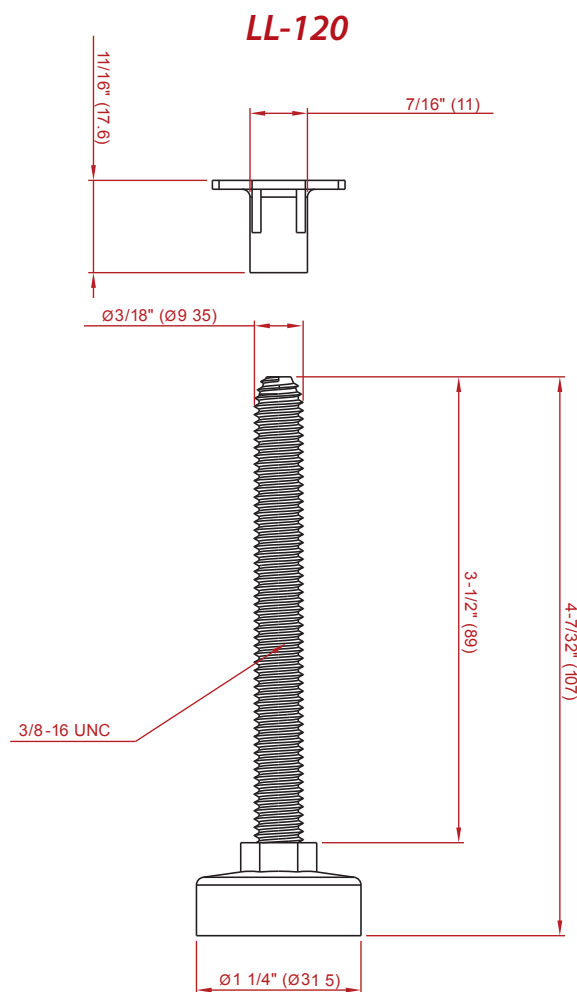

LL-40

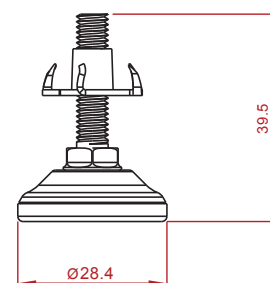

Hanging File Accessories



- » Easy and fast install – no cutting or grooving is necessary
- » Steel bars and clips are dependable and durable
- » Top-mount or side-mount clip attachment
- » Hanging file bar cross rail can be cut to length and fits 1/2" and 5/8" clips



1/4" diameter steel x 11-7/8" length file rod

3 mm thick x 1/2" tall x 96" length file bar

File bar clip for 1/2" drawer side material

File bar clip for 5/8" drawer side material

Black Plated

092182BLK*
200 pcs/ctn

Zinc Plated

1296ZN
10 sticks/ctn

464ZN
1000 pcs/ctn

580ZN
100 pcs/box
1000 pcs/master ctn

Recommended screw:

#6 pan head

#6 pan head

**Can only be used with clip for 1/2" material*

092182BLK

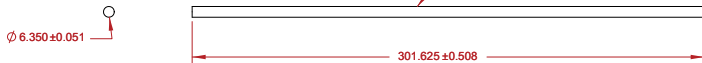

1296ZN

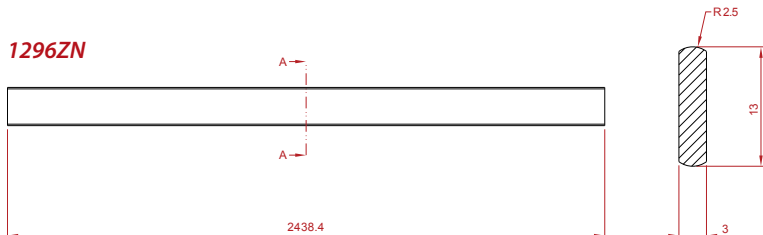

464ZN

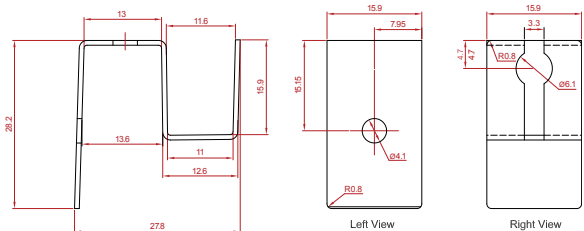
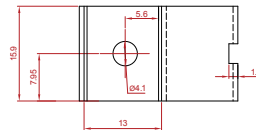

Hanging File Kit

Commercial
Hardware

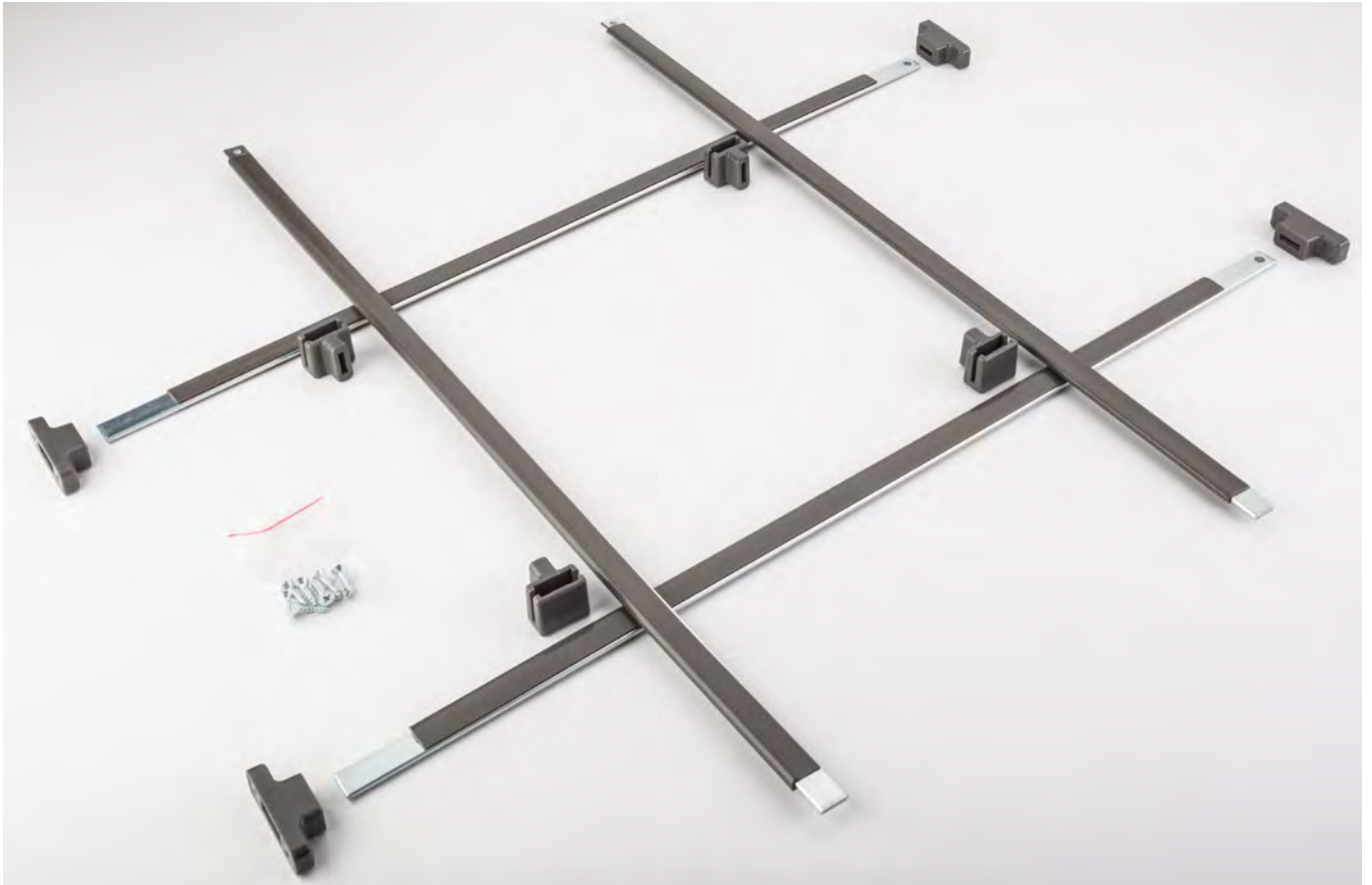

- » Complete installation package (includes all parts)
- » Mounts inside the drawer for a cleaner appearance
- » No hooks that hang over the top edge of the drawer
- » Quick and easy to install
- » Cut-to-fit rods for variations in drawer size
- » Instructions included

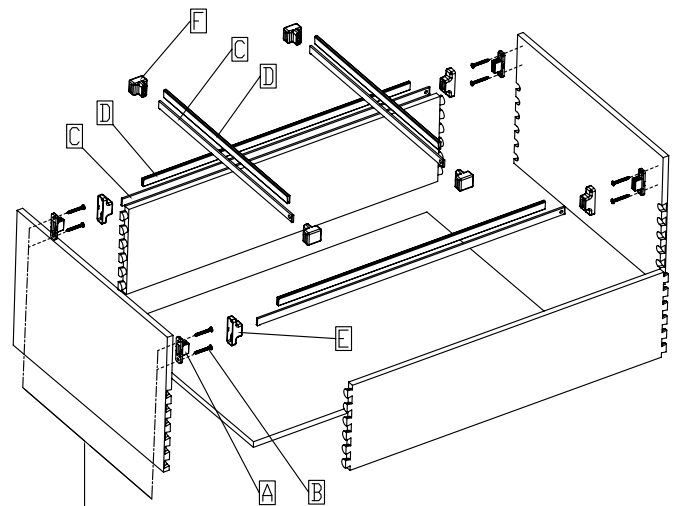

CENTERS:
letter = 310 mm (12-3/16")
legal = 386 mm (15-3/16")

Contents List:









- 4 Rail Support Brackets (A)
- 8 Wood Screws (B)
- 4 Side Hanging Rails (C)
- 4 Side Hanging Rail Covers (D)
- 4 Rail Support Bracket Covers (E)
- 4 Lateral Brackets (F)

Hanging File Kit

Grey

FILE-KIT-GR
20 pks/ctn



		3" center-to-center	3-1/2" center-to-center	96 mm (3-3/4") center-to-center	4" center-to-center	128 mm (5") center-to-center
	Aluminum	A271-3AL 30 pcs/ctn	A271-3.5AL 30 pcs/ctn	A271-96AL 30 pcs/ctn	A271-4AL 30 pcs/ctn	
	Stainless Steel	K271-3SS 30 pcs/ctn	K271-3.5-SS 30 pcs/ctn	K271-96-SS 30 pcs/ctn	K271-4SS 30 pcs/ctn	
	Almond Powder Coated Steel	S271-3ALM 30 pcs/ctn		S271-96ALM 30 pcs/ctn		
	Brushed Chrome Plated Steel	S271-3BC 30 pcs/ctn	S271-3.5BC 30 pcs/ctn	S271-96BC 30 pcs/ctn	S271-4BC 30 pcs/ctn	S271-128BC 20 pcs/ctn
	Brushed Oil Rubbed Bronze Plated Steel	S271-3DBAC 30 pcs/ctn	S271-3.5DBAC 30 pcs/ctn	S271-96DBAC 30 pcs/ctn	S271-4DBAC 30 pcs/ctn	S271-128DBAC 20 pcs/ctn
	Polished Brass Plated Steel	S271-3PB 30 pcs/ctn	S271-3.5PB 30 pcs/ctn	S271-96PB 30 pcs/ctn	S271-4PB 30 pcs/ctn	S271-128PB 20 pcs/ctn
	Polished Chrome Plated Steel	S271-3PC 30 pcs/ctn	S271-3.5PC 30 pcs/ctn	S271-96PC 30 pcs/ctn	S271-4PC 30 pcs/ctn	S271-128PC 20 pcs/ctn
	Satin Nickel Plated Steel	S271-3SN 30 pcs/ctn	S271-3.5SN 30 pcs/ctn	S271-96SN 30 pcs/ctn	S271-4SN 30 pcs/ctn	S271-128SN 20 pcs/ctn
	White Powdercoated Steel	S271-3WH 30 pcs/ctn		S271-96WH 30 pcs/ctn		



Hardware Resources believes in quality, integrity, and reliability. We uphold the highest standards of service and responsibility in the industry.

As such, Hardware Resources warrants our commercial hardware products against defects in material and workmanship as long as the original consumer purchaser owns the products, if the original consumer purchased the products from an authorized distributor of Hardware Resources. Hardware Resources cannot guarantee the quality or condition of products from distributors who do not agree to meet our high standards, and therefore, no warranty is provided for products from unauthorized sellers.

Hardware Resources will send the original consumer purchaser, without charge, a new product to replace any defective product subject to this warranty. This warranty is a warranty of replacement only. Hardware Resources specifically does not warrant removal of the defective product nor installation of the replacement product. This warranty does not cover products that have been incorrectly installed, exposed to excessive loads or otherwise used in a manner contrary to their intended purpose. In the event the defective Hardware Resources commercial hardware item is obsolete or has been discontinued, Hardware Resources reserves the right to replace the defective product with a current offering.

In the unlikely event that a defective commercial hardware item is encountered, please contact Customer Service at 800.463.0660. Please be able to provide a brief description and photographs of the defect.



New Product Line!

Decorative Hooks

Coming Winter 2017-18

All Hardware Resources hooks are:

- Made to last – They are manufactured out of zinc die-cast and are weight tested to hold up to 35 lbs.
- Same Beautiful Finishes – Available in the same popular finishes as our Jeffrey Alexander and Elements decorative cabinet hardware for a cohesive look throughout the house.
- Lifetime Warranty – Hardware Resources believes in quality, integrity and reliability by offering a lifetime warranty on all of our hooks (see page 184).

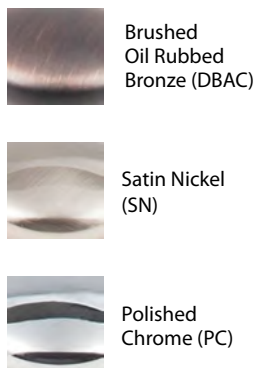
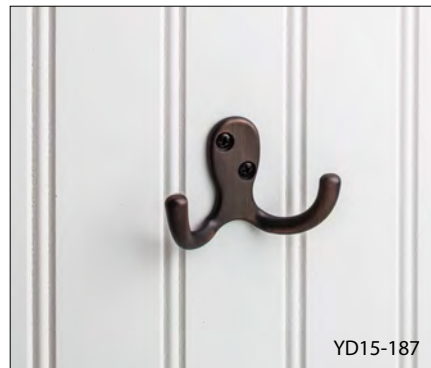
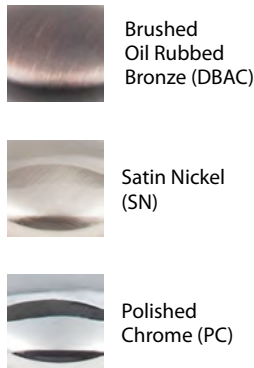
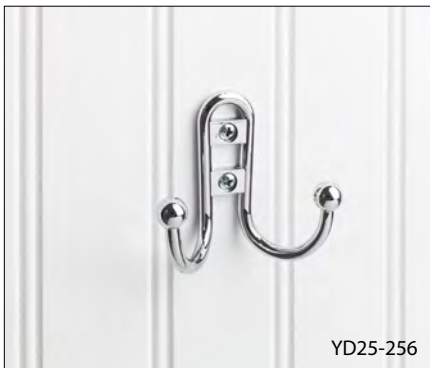

See our full offering of decorative hooks starting on page 178.

