

SHACKLES

The Crosby Group, Inc.

Angle loads must be applied in the plane of the bow.

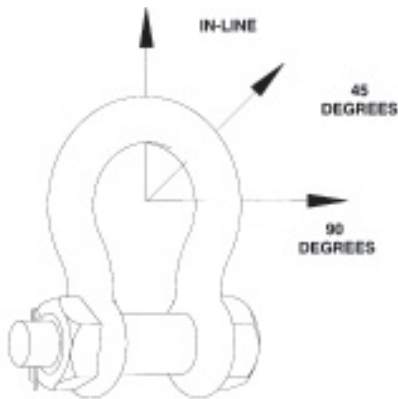

Never Exceed 120° included angle. Use Bolt Type and Screw Pin Shackles ONLY.

Shackles symmetrically loaded with two legs slings having a maximum included angle of 120° can be utilized to full Working Load Limit.

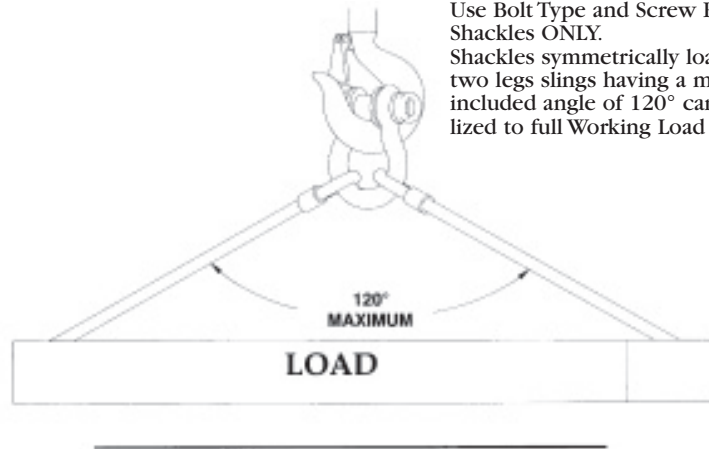

Side Loading Reduction Chart For Screw Pin and Bolt Type Shackles Only†	
Angle of Side Load from Vertical In-Line of Shackle	Adjusted Working Load Limit
0° In-Line *	100% of Rated Working Load Limit
45° from In-Line *	70% of Rated Working Load Limit
90° from In-Line *	50% of Rated Working Load Limit

* In-Line load is applied perpendicular to pin.
† DO NOT SIDE LOAD ROUND PIN SHACKLES



10

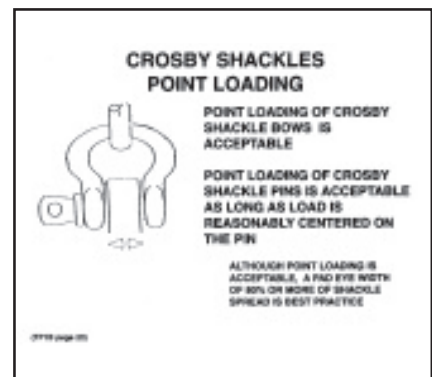
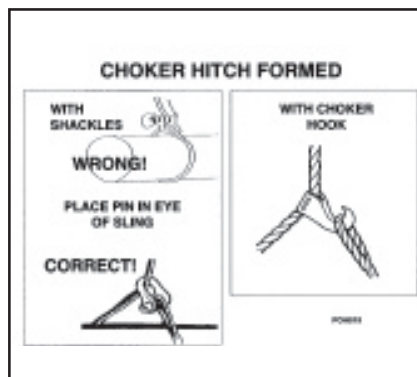
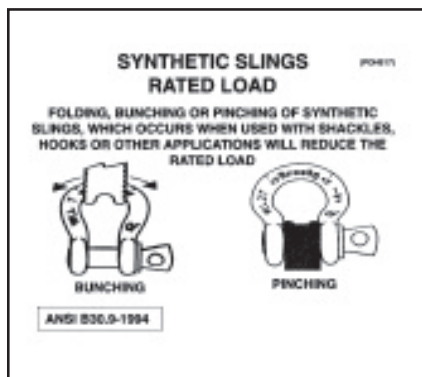

SHACKLES

The Crosby Group, Inc.

Forged Shackles

SCREW PIN



G-209 S-209

Screw pin anchor shackles meet the performance requirements of Federal Specification RR-C-271D Type IVA, Grade A, Class 2, except for those provisions required of the contractor.

ROUND PIN



G-213 S-213

Round pin anchor shackles meet the performance requirements of Federal Specification RR-C-271D Type IVA, Grade A, Class 1, except for those provisions required of the contractor.

209

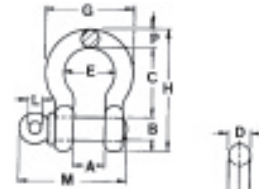

213

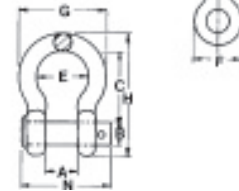

- Working Load Limit permanently shown on every shackle
- Forged — Quenched and Tempered, with alloy pins.
- Shackles can be furnished proof tested with certificates to designated standards, such as ABS, DNV, Lloyds, or other certification. Charges for proof testing and certification available when requested at the time of order.
- Hot Dip galvanized or Self Colored.

Nominal Size (in.)	Working Load Limit* (tons)	G-209 Galv.		S-209 S.C.		G-213 Galv.		S-213 S.C.		Weight Each (lbs.)	
		CERTEX Cat. Ref. No.	Crosby Stock No.	CERTEX Cat. Ref. No.	Crosby Stock No.	CERTEX Cat. Ref. No.	Crosby Stock No.	CERTEX Cat. Ref. No.	Crosby Stock No.	G-209 S-209	G-213 S-213
3/16	† 1/3	CX10-0001	1018357	—	—	—	—	—	—	.06	—
1/4	1/2	CX10-0002	1018375	CX10-0018	1018384	CX10-0034	1018017	CX10-0049	1018026	.10	.13
5/16	3/4	CX10-0003	1018393	CX10-0019	1018400	CX10-0035	1018035	CX10-0050	1018044	.19	.18
3/8	1	CX10-0004	1018419	CX10-0020	1018428	CX10-0036	1018053	CX10-0051	1018062	.31	.29
7/16	1 1/2	CX10-0005	1018437	CX10-0021	1018446	CX10-0037	1018071	CX10-0052	1018080	.38	.38
1/2	2	CX10-0006	1018455	CX10-0022	1018464	CX10-0038	1018099	CX10-0053	1018106	.72	.71
5/8	3 1/4	CX10-0007	1018473	CX10-0023	1018482	CX10-0039	1018115	CX10-0054	1018124	1.37	1.50
3/4	4 3/4	CX10-0008	1018491	CX10-0024	1018507	CX10-0040	1018133	CX10-0055	1018142	2.35	2.32
7/8	6 1/2	CX10-0009	1018516	CX10-0025	1018525	CX10-0041	1018151	CX10-0056	1018160	3.62	3.49
1	8 1/2	CX10-0010	1018534	CX10-0026	1018543	CX10-0042	1018179	CX10-0057	1018188	5.03	5.00
1 1/8	9 1/2	CX10-0011	1018552	CX10-0027	1018561	CX10-0043	1018197	CX10-0058	1018204	7.41	6.97
1 1/4	12	CX10-0012	1018570	CX10-0028	1018589	CX10-0044	1018213	CX10-0059	1018222	9.50	9.75
1 3/8	13 1/2	CX10-0013	1018598	CX10-0029	1018605	CX10-0045	1018231	CX10-0060	1018240	13.53	13.25
1 1/2	17	CX10-0014	1018614	CX10-0030	1018623	CX10-0046	1018259	CX10-0061	1018268	17.20	17.25
1 3/4	25	CX10-0015	1018632	CX10-0031	1018641	CX10-0047	1018277	CX10-0062	1018286	27.78	29.46
2	35	CX10-0016	1018650	CX10-0032	1018669	CX10-0048	1018295	CX10-0063	1018302	45.00	45.75
2 1/2	†55	CX10-0017	1018678	CX10-0033	1018687	—	—	—	—	85.75	—

† Furnished in screw pin only.

* NOTE: Maximum Proof Load is 2.2 times the Working Load Limit. Minimum Ultimate Strength is 6 times the Working Load Limit. For Working Load Limit reduction due to side loading applications, see beginning of chapter.

10

Nominal Size (in.)	Working Load Limit* (tons)	Dimensions (in.)													Tolerance	
		A	B	C	D	E	F	G	H	L	M	N	P	C	A	
3/16	† 1/3	.38	.25	.88	.19	.60	.56	.98	1.47	.16	1.12	—	.19	.06	.06	
1/4	1/2	.47	.31	1.13	.25	.78	.61	1.28	1.84	.19	1.38	1.34	.25	.06	.06	
5/16	3/4	.53	.38	1.22	.31	.84	.75	1.47	2.09	.22	1.66	1.59	.31	.06	.06	
3/8	1	.66	.44	1.44	.38	1.03	.91	1.78	2.49	.25	2.03	1.86	.38	.13	.06	
7/16	1 1/2	.75	.50	1.69	.44	1.16	1.06	2.03	2.91	.31	2.38	2.13	.44	.13	.06	
1/2	2	.81	.63	1.88	.50	1.31	1.19	2.31	3.28	.38	2.69	2.38	.50	.13	.06	
5/8	3 1/4	1.06	.75	2.38	.63	1.69	1.50	2.94	4.19	.44	3.34	2.91	.69	.13	.06	
3/4	4 3/4	1.25	.88	2.81	.75	2.00	1.81	3.50	4.97	.50	3.97	3.44	.81	.25	.06	
7/8	6 1/2	1.44	1.00	3.31	.88	2.28	2.09	4.03	5.83	.50	4.50	3.81	.97	.25	.06	
1	8 1/2	1.69	1.13	3.75	1.00	2.69	2.38	4.69	6.56	.56	5.07	4.53	1.06	.25	.06	
1 1/8	9 1/2	1.81	1.25	4.25	1.16	2.91	2.69	5.16	7.47	.63	5.59	5.13	1.25	.25	.06	
1 1/4	12	2.03	1.38	4.69	1.29	3.25	3.00	5.75	8.25	.69	6.16	5.50	1.38	.25	.06	
1 3/8	13 1/2	2.25	1.50	5.25	1.42	3.63	3.31	6.38	9.16	.75	6.84	6.13	1.50	.25	.13	
1 1/2	17	2.38	1.63	5.75	1.54	3.88	3.63	6.88	10.00	.81	7.35	6.50	1.62	.25	.13	
1 3/4	25	2.88	2.00	7.00	1.84	5.00	4.19	8.86	12.34	1.00	9.08	7.75	2.25	.25	.13	
2	35	3.25	2.25	7.75	2.08	5.75	4.81	9.97	13.68	1.22	10.34	8.75	2.40	.25	.13	
2 1/2	†55	4.13	2.75	10.50	2.71	7.25	5.69	12.87	17.84	1.38	13.00	—	3.13	.25	.25	

† Furnished in screw pin only.

* NOTE: Maximum Proof Load is 2.2 times the Working Load Limit. Minimum Ultimate Strength is 6 times the Working Load Limit. For Working Load Limit reduction due to side loading applications, see beginning of chapter.

SHACKLES

The Crosby Group, Inc.

Alloy Screw Pin Anchor Shackle



G-209-A

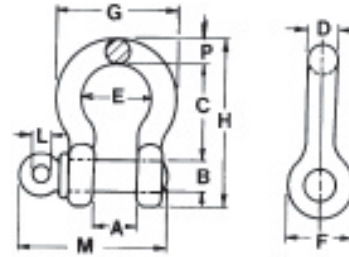

G-209-A

Screw pin anchor shackles meet the performance requirements of Federal Specification RR-C-271D Type IVA, Grade B, Class 2, except for those provisions required of the contractor.

- Working Load Limit permanently shown on every shackle.
- Forged Alloy Steel — Quenched and Tempered, with alloy pins.
- Shackles can be furnished proof tested with certificates to designated standards, such as ABS, DNV, Lloyds, or other certification. Charges for proof testing and certification available when requested at time of order.
- Hot Dip galvanized.

Nominal Size (in.)	Working Load Limit* (tons)	CERTEX Cat. Ref. No.	G-209-A Crosby Stock No. Galv.	Weight Each (lbs.)
3/8	2.0	CX10-0064	1017450	.31
7/16	2.6	CX10-0065	1017472	.38
1/2	3.3	CX10-0066	1017494	.63
5/8	5.0	CX10-0067	1017516	1.38
3/4	7.0	CX10-0068	1017538	2.25
7/8	9.5	CX10-0069	1017560	3.61
1	12.5	CX10-0070	1017582	5.32
1 1/8	15.0	CX10-0071	1017604	7.25
1 1/4	18.0	CX10-0072	1017626	9.88
1 3/8	21.0	CX10-0073	1017648	13.25

* Note: Maximum Proof Load is 2.5 times the Working Load Limit. Minimum Ultimate Strength is 5 times the Working Load Limit. For Working Load Limit reduction due to side loading applications, see beginning of chapter.

Nominal Size (in.)	Working Load Limit* (tons)	Dimensions (in.)											Tolerance +/-	
		A	B	C	D	E	F	G	H	L	M	P	C	A
3/8	2.0	.66	.44	1.44	.38	1.03	.91	1.78	2.49	.25	2.03	.38	.13	.06
7/16	2.6	.75	.50	1.69	.44	1.16	1.06	2.03	2.91	.31	2.38	.44	.13	.06
1/2	3.3	.81	.63	1.88	.50	1.31	1.19	2.31	3.28	.38	2.69	.50	.13	.06
5/8	5.0	1.06	.75	2.38	.63	1.69	1.50	2.94	4.19	.44	3.34	.69	.13	.06
3/4	7.0	1.25	.88	2.81	.75	2.00	1.81	3.50	4.97	.50	3.97	.81	.25	.06
7/8	9.5	1.44	1.00	3.31	.88	2.28	2.09	4.03	5.83	.50	4.50	.97	.25	.06
1	12.5	1.69	1.13	3.75	1.00	2.69	2.38	4.69	6.56	.56	5.07	1.06	.25	.06
1 1/8	15.0	1.81	1.25	4.25	1.16	2.91	2.69	5.16	7.47	.63	5.59	1.25	.25	.06
1 1/4	18.0	2.03	1.38	4.69	1.29	3.25	3.00	5.75	8.25	.69	6.16	1.38	.25	.06
1 3/8	21.0	2.25	1.50	5.25	1.42	3.63	3.31	6.38	9.16	.75	6.84	1.50	.25	.13

* Note: Maximum Proof Load is 2.5 times the Working Load Limit. Minimum Ultimate Strength is 5 times the Working Load Limit. For Working Load Limit reduction due to side loading applications, see beginning of chapter.

SHACKLES

The Crosby Group, Inc.

Forged Chain Shackles

SCREW PIN



ROUND PIN

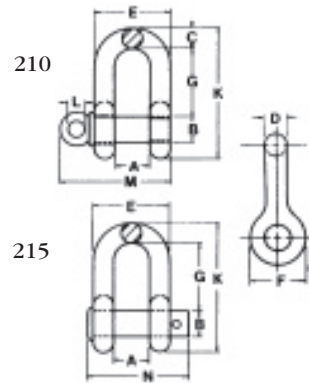

G-210 S-210

Screw pin chain shackles meet the performance requirements of Federal Specification RR-C-271D, Type IVB, Grade A, Class 2, except for those provisions required of the contractor.

G-215 S-215

Round pin chain shackles meet the performance requirements of Federal Specification RR-C-271D Type IVB, Grade A, Class 1, except for those provisions required of the contractor.

- Working Load Limit permanently shown on every shackle.
- Forged — Quenched and Tempered, with alloy pins.
- Shackles can be furnished proof tested with certificates to designated standards, such as ABS, DNV, Lloyds, or other certification. Charges for proof testing and certification available when requested at the time of order.
- Hot Dip galvanized or Self Colored.
- Fatigue rated.

Nominal Shackle Size (in.)	Working Load Limit* (tons)	G-210 Galv.		S-210 S.C.		G-215 Galv.		S-215 S.C.		Weight Each (lbs.)	
		CERTEX Cat. Ref. No.	Crosby Stock. No.	CERTEX Cat. Ref. No.	Crosby Stock. No.	CERTEX Cat. Ref. No.	Crosby Stock. No.	CERTEX Cat. Ref. No.	Crosby Stock. No.	G-210 S-210	G-215 S-215
1/4	1/2	CX10-0074	1019150	CX10-0090	1019169	CX10-0106	1018810	CX10-0121	1018829	.11	.10
5/16	3/4	CX10-0075	1019178	CX10-0091	1019187	CX10-0107	1018838	CX10-0122	1018847	.17	.18
3/8	1	CX10-0076	1019196	CX10-0092	1019203	CX10-0108	1018856	CX10-0123	1018865	.28	.25
7/16	1 1/2	CX10-0077	1019212	CX10-0093	1019221	CX10-0109	1018874	CX10-0124	1018883	.43	.40
1/2	2	CX10-0078	1019230	CX10-0094	1019249	CX10-0110	1018892	CX10-0125	1018909	.59	.50
5/8	3 1/4	CX10-0079	1019258	CX10-0095	1019267	CX10-0111	1018918	CX10-0126	1018927	1.25	1.21
3/4	4 3/4	CX10-0080	1019276	CX10-0096	1019285	CX10-0112	1018936	CX10-0127	1018945	2.63	2.00
7/8	6 1/2	CX10-0081	1019294	CX10-0097	1019301	CX10-0113	1018954	CX10-0128	1018963	3.16	3.28
1	8 1/2	CX10-0082	1019310	CX10-0098	1019329	CX10-0114	1018972	CX10-0129	1018981	4.75	4.75
1 1/8	9 1/2	CX10-0083	1019338	CX10-0099	1019347	CX10-0115	1018990	CX10-0130	1019007	6.75	6.30
1 1/4	12	CX10-0084	1019356	CX10-0100	1019365	CX10-0116	1019016	CX10-0131	1019025	9.06	9.00
1 3/8	13 1/2	CX10-0085	1019374	CX10-0101	1019383	CX10-0117	1019034	CX10-0132	1019043	11.63	12.00
1 1/2	17	CX10-0086	1019392	CX10-0102	1019409	CX10-0118	1019052	CX10-0133	1019061	15.95	16.15
1 3/4	25	CX10-0087	1019418	CX10-0103	1019427	CX10-0119	1019070	CX10-0134	1019089	26.75	29.96
2	35	CX10-0088	1019436	CX10-0104	1019445	CX10-0120	1019098	CX10-0135	1019105	42.31	43.25
2 1/2	†55	CX10-0089	1019454	CX10-0105	1019463	—	—	—	—	71.75	—

† Furnished in Screw Pin Only.

* NOTE: Maximum Proof Load is 2.2 times the Working Load Limit. Minimum Ultimate Load is 6 times the Working Load Limit. For Working Load Limit reduction due to side loading applications, see beginning of chapter.

10

Nominal Size (in.)	Working Load Limit* (tons)	Dimensions (in.)												Tolerance	
		A	B	C	D	E	F	G	K	L	M	N	G	A	
1/4	1/2	.47	.31	.25	.25	.97	.61	.88	1.59	.19	1.38	1.34	.06	.06	
5/16	3/4	.53	.38	.31	.31	1.16	.75	1.03	1.91	.22	1.66	1.59	.06	.06	
3/8	1	.66	.44	.38	.38	1.41	.91	1.25	2.30	.25	2.03	1.86	.13	.06	
7/16	1 1/2	.75	.50	.44	.44	1.63	1.06	1.44	2.66	.31	2.38	2.13	.13	.06	
1/2	2	.81	.63	.50	.50	1.81	1.19	1.63	3.03	.38	2.69	2.38	.13	.06	
5/8	3 1/4	1.06	.75	.62	.63	2.31	1.50	2.00	3.75	.44	3.34	2.91	.13	.06	
3/4	4 3/4	1.25	.88	.81	.75	2.75	1.81	2.38	4.53	.50	3.97	3.44	.25	.06	
7/8	6 1/2	1.44	1.00	.97	.88	3.19	2.09	2.81	5.33	.50	4.50	3.81	.25	.06	
1	8 1/2	1.69	1.13	1.00	1.00	3.69	2.38	3.19	5.94	.56	5.07	4.53	.25	.06	
1 1/8	9 1/2	1.81	1.25	1.25	1.13	4.06	2.69	3.58	6.78	.63	5.59	5.13	.25	.06	
1 1/4	12	2.03	1.38	1.38	1.25	4.53	3.00	3.94	7.50	.69	6.16	5.50	.25	.13	
1 3/8	13 1/2	2.25	1.50	1.50	1.38	5.00	3.31	4.38	8.28	.75	6.84	6.13	.25	.13	
1 1/2	17	2.38	1.63	1.62	1.50	5.38	3.62	4.81	9.06	.81	7.35	6.50	.25	.13	
1 3/4	25	2.88	2.00	2.12	1.75	6.38	4.19	5.75	10.97	1.00	9.08	7.75	.25	.13	
2	35	3.25	2.25	2.00	2.00	7.25	4.81	6.75	12.28	1.22	10.34	8.75	.25	.13	
2 1/2	†55	4.13	2.75	2.62	2.62	9.38	5.69	8.00	14.84	1.38	13.00	—	.25	.25	

† Furnished in Screw Pin Only.

* NOTE: Maximum Proof Load is 2.2 times the Working Load Limit. Minimum Ultimate Load is 6 times the Working Load Limit. For Working Load Limit reduction due to side loading applications, see beginning of chapter.

SHACKLES

The Crosby Group, Inc.

Bolt Type Shackles

BOLT TYPE ANCHOR SHACKLE



G-2130 S-2130

Bolt Type Anchor shackles with thin head bolt — nut with cotter pin. Meets the performance requirements of Federal Specification RR-C-271D Type IVA, Grade A, Class 3, except for those provisions required of the contractor.

BOLT TYPE CHAIN SHACKLE



G-2150 S-2150

Bolt Type Chain shackles. Thin hex head bolt — nut with cotter pin. Meets the performance requirements of Federal Specification RR-C271D Type IVB, Grade A, Class 3, except for those provisions required of the contractors.

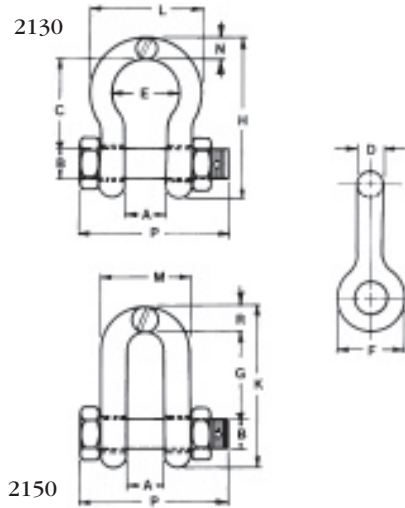

- Working Load Limit permanently shown on every shackle.
- Forged — Quenched and Tempered, with alloy pins.
- Shackles 55 tons and smaller can be furnished proof tested with certificates to designated standards, such as ABS, DNV, Lloyds, or other certification.
 - Shackles 85 tons and larger can be provided as follows.
 - Non Destructive Tested
 - Serialized Pin and Bow
- Material Certification (Chemical)
- Certification must be requested at time of order.
- Hot Dip galvanized or Self-Colored.
- Fatigue rated.

10

CERTEX

Lifting Products and Services

SHACKLES

The Crosby Group, Inc.

Bolt Type Shackles

Nominal Shackle Size (in.)	Working Load Limit* (tons)	G-2130 Galv.		S-2130 S.C.		G-2150 Galv.		S-2150 S.C.		2130 Weight Each (lbs.)	2150 Weight Each (lbs.)
		CERTEX Cat. Ref. No.	Crosby Stock No.	CERTEX Cat. Ref. No.	Crosby Stock No.	CERTEX Cat. Ref. No.	Crosby Stock No.	CERTEX Cat. Ref. No.	Crosby Stock No.		
3/16	1/3 ‡	CX10-0136	1019464	—	—	—	—	—	—	.06	—
1/4	1/2	CX10-0137	1019466	—	—	CX10-0168	1019768	—	—	.11	.13
5/16	3/4	CX10-0138	1019468	—	—	CX10-0169	1019770	—	—	.22	.23
3/8	1	CX10-0139	1019470	—	—	CX10-0170	1019772	—	—	.33	.33
7/16	1 1/2	CX10-0140	1019471	—	—	CX10-0171	1019774	—	—	.49	.49
1/2	2	CX10-0141	1019472	CX10-0156	1019481	CX10-0172	1019775	CX10-0185	1019784	.79	.75
5/8	3 1/4	CX10-0142	1019490	CX10-0157	1019506	CX10-0173	1019793	CX10-0186	1019800	1.68	1.47
3/4	4 3/4	CX10-0143	1019515	CX10-0158	1019524	CX10-0174	1019819	CX10-0187	1019828	2.72	2.52
7/8	6 1/2	CX10-0144	1019533	CX10-0159	1019542	CX10-0175	1019837	CX10-0188	1019846	3.95	3.85
1	8 1/2	CX10-0145	1019551	CX10-0160	1019560	CX10-0176	1019855	CX10-0189	1019864	5.66	5.55
1 1/8	9 1/2	CX10-0146	1019579	CX10-0161	1019588	CX10-0177	1019873	CX10-0190	1019882	8.27	7.60
1 1/4	12	CX10-0147	1019597	CX10-0162	1019604	CX10-0178	1019891	CX10-0191	1019908	11.71	10.81
1 3/8	13 1/2	CX10-0148	1019613	CX10-0163	1019622	CX10-0179	1019917	CX10-0192	1019926	15.83	13.75
1 1/2	17	CX10-0149	1019631	CX10-0164	1019640	CX10-0180	1019935	CX10-0193	1019944	20.80	18.50
1 3/4	25	CX10-0150	1019659	CX10-0165	1019668	CX10-0181	1019953	CX10-0194	1019962	33.91	31.40
2	35	CX10-0151	1019677	CX10-0166	1019686	CX10-0182	1019971	CX10-0195	1019980	52.25	46.75
2 1/2	55	CX10-0152	1019695	CX10-0167	1019702	CX10-0183	1019999	CX10-0196	1020004	98.25	85.00
3	† 85	CX10-0153	1019711	—	—	CX10-0184	1020013	—	—	154.00	124.25
3 1/2	† 120 ‡	CX10-0154	1019739	—	—	—	—	—	—	265.00	—
4	† 150 ‡	CX10-0155	1019757	—	—	—	—	—	—	338.00	—

* NOTE: Maximum Proof Load is 2.2 times the Working Load Limit. Minimum Ultimate Load is 6 times the Working Load Limit. For Working Load Limit reduction due to side loading applications, see beginning of chapter.

† Individually Proof Tested with certification and furnished with Round Head Bolts and welded handle.

‡ Furnished in anchor style only.

Nominal Size (in.)	Working Load Limit (t)*	Stock No.		Weight Each (lbs.)	Dimensions (in.)										Tolerance +/-	
		G-2150	S-2150		A	B	D	F	G	K	M	P	R	G	A	
1/4	1/2	1019768	-	.13	.47	.31	.25	.62	.91	1.59	.97	1.56	.25	.06	.06	
5/16	3/4	1019770	-	.23	.53	.38	.31	.75	1.07	1.91	1.15	1.82	.31	.06	.06	
3/8	1	1019772	-	.33	.66	.44	.38	.92	1.28	2.31	1.42	2.17	.38	.13	.06	
7/16	1-1/2	1019774	-	.49	.75	.50	.44	1.06	1.48	2.67	1.63	2.51	.44	.13	.06	
1/2	2	1019775	1019784	.75	.81	.64	.50	1.18	1.66	3.03	1.81	2.80	.50	.13	.06	
5/8	3-1/4	1019793	1019800	1.47	1.06	.77	.63	1.50	2.04	3.76	2.32	3.56	.63	.13	.06	
3/4	4-3/4	1019819	1019828	2.52	1.25	.89	.75	1.81	2.40	4.53	2.75	4.15	.81	.25	.06	
7/8	6-1/2	1019837	1019846	3.85	1.44	1.02	.88	2.10	2.86	5.33	3.20	4.82	.97	.25	.06	
1	8-1/2	1019855	1019864	5.55	1.69	1.15	1.00	2.38	3.24	5.94	3.69	5.39	1.00	.25	.06	
1-1/8	9-1/2	1019873	1019882	7.60	1.81	1.25	1.13	2.68	3.61	6.78	4.07	5.90	1.25	.25	.06	
1-1/4	12	1019891	1019908	10.81	2.03	1.40	1.25	3.00	3.97	7.50	4.53	6.69	1.38	.25	.06	
1-3/8	13-1/2	1019917	1019926	13.75	2.25	1.53	1.38	3.31	4.43	8.28	5.01	7.21	1.50	.25	.13	
1-1/2	17	1019935	1019944	18.50	2.38	1.66	1.50	3.62	4.87	9.05	5.38	7.73	1.62	.25	.13	
1-3/4	25	1019953	1019962	31.40	2.88	2.04	1.75	4.19	5.82	10.97	6.38	9.33	2.12	.25	.13	
2	35	1019971	1019980	46.75	3.25	2.30	2.10	5.00	6.82	12.74	7.25	10.41	2.36	.25	.13	
2-1/2	55	1019999	1020004	85.00	4.12	2.80	2.63	5.68	8.07	14.85	9.38	13.58	2.63	.25	.25	
3	† 85	1020013	-	124.25	5.00	3.25	3.00	6.50	8.56	16.87	11.00	15.13	3.50	.25	.25	

* NOTE: Maximum Proof Load is 2.2 times the Working Load Limit. Minimum Ultimate Load is 6 times the Working Load Limit. For Working Load Limit reduction due to side load applications, see beginning of chapter.

† Individually Proof Tested with certification and furnished with Round Head Bolts and welded handle.

‡ Furnished in Anchor style only.

SHACKLES

The Crosby Group, Inc.

Alloy Bolt Type Anchor Shackle

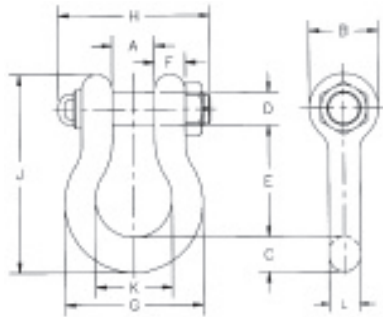

G-2140 and S-2140

G-2140 meets the performance requirements of Federal Specification RR-C-271D, Type IVA, Grade B, Class 3, except for those provisions required of the contractor.

- Working Load Limit is permanently shown on every shackle.
- Alloy bows, Alloy bolts.
- Quenched and Tempered.
- All sizes are individually proof tested to 2.2 times the Working Load Limit.
 - Shackles 110 tons and larger are provided as follows.
 - Non Destructive Tested
 - Serialized Pin and Bow
 - Material Certification (Chemical)
 - Certification must be requested at time of order.
- Forged Alloy Steel 30 thru 175 tons. Cast Alloy Steel 200 thru 600 tons.
- Pins are galvanized and painted red.

NOTICE: All 2140 shackles 110 tons and larger are magnetic particle inspected. Certification available on request.

Nominal Shackle Size (in.)	Working Load Limit* (tons)	G-2140 Galv.		S-2140 S.C.		Weight Each (lbs.)
		CERTEX Cat. Ref. No.	Crosby Stock No.	CERTEX Cat. Ref. No.	Crosby Stock No.	
1 1/2	30	CX10-0197	1021110	CX10-0210	1021129	20.8
1 3/4	40	CX10-0198	1021138	CX10-0211	1021147	33.9
2	50	CX10-0199	1021156	CX10-0212	1021165	52.0
2 1/2	80	CX10-0200	1021174	CX10-0213	1021183	96.0
3	† 110	CX10-0201	1021192	—	—	178.0
3 1/2	† 140	CX10-0202	1021218	—	—	265.0
4	† 175	CX10-0203	1021236	—	—	338.0
4 3/4 **	† 200	CX10-0204	1021414	—	—	450.0
5 **	† 250	CX10-0205	1021432	—	—	600.0
6 **	† 300	CX10-0206	1021450	—	—	775.0
7 **	† 400	CX10-0207	1021478	—	—	1102.0
7 1/2 **	†† 500	CX10-0208	1021496	—	—	1552.0
8 **	†† 600	CX10-0209	1021511	—	—	1900.0

* Note: Maximum Proof Load is 2.2 times the Working Load Limit. Minimum Ultimate Load is 4 times the Working Load Limit on 200 thru 600 Tons. For sizes 30 thru 175 Tons, Minimum Ultimate Load is 6 times the Working Load Limit.

** Cast Alloy Steel.

† Furnished with Round Head Bolts with welded handle.

†† Maximum Proof Load is 1000 Tons and furnished with Round Head Bolts with welded handle.

Nominal Shackle Size (in.)	Working Load Limit* (tons)	Dimensions (in.)											Tolerance +/-	
		A	B	C	D	E	F	G	H	J	K	L	A	E
1 1/2	30	2.38	3.62	1.62	1.63	5.75	1.39	6.88	7.75	10.00	3.88	1.54	.13	.25
1 3/4	40	2.88	4.19	2.25	2.00	7.00	1.75	8.86	9.06	12.34	5.00	1.84	.13	.25
2	50	3.25	4.81	2.40	2.25	7.75	2.00	9.97	10.41	13.68	5.75	2.08	.13	.25
2 1/2	80	4.12	5.69	3.12	2.75	10.50	2.62	12.87	13.56	17.84	7.25	2.71	.25	.25
3	† 110	5.00	6.50	3.62	3.25	13.00	3.00	14.36	16.50	21.50	7.88	3.11	.25	.25
3 1/2	† 140	5.25	8.00	4.12	3.75	14.63	3.75	16.50	19.00	24.62	9.00	3.62	.25	.25
4	† 175	5.50	9.00	4.56	4.25	14.50	4.00	18.42	19.75	25.69	10.00	4.10	.25	.25
4 3/4 **	† 200	7.25	10.50	6.00	4.75	15.62	3.75	21.00	20.50	29.25	11.00	4.50	.25	.25
5 **	† 250	8.50	12.00	6.50	5.00	20.00	3.88	24.50	21.97	35.00	13.00	4.50	.25	.25
6 **	† 300	8.38	12.00	6.75	6.00	19.50	4.75	25.00	24.35	35.25	13.00	5.00	.25	.25
7 **	† 400	8.25	14.00	7.25	7.00	22.50	6.50	26.00	27.97	40.25	13.00	6.00	.25	.25
7 1/2 **	†† 500	8.31	15.00	7.50	7.50	25.25	6.34	28.00	28.22	44.00	13.00	7.50	.25	.25
8 **	†† 600	9.25	17.00	8.50	8.25	31.88	6.50	31.00	29.97	53.00	14.00	8.50	.25	.25

* Note: Maximum Proof Load is 2.2 times the Working Load Limit. Minimum Ultimate Load is 4 times the Working Load Limit on 200 thru 600 Tons. For sizes 30 thru 175 Tons, Minimum Ultimate Load is 6 times the Working Load Limit.

** Cast Alloy Steel.

† Furnished with Round Head Bolts with welded handle.

†† Maximum Proof Load is 1000 Tons and furnished with Round Head Bolts with welded handle.

SHACKLES

Crosby® Alloy Shackles

“WIDE BODY” SLING SAVER SHACKLES INCREASE SLING LIFE



G-2160

Patented

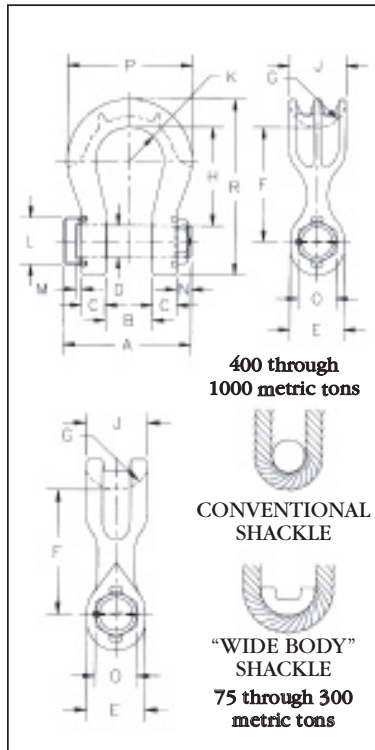

- Greatly improves wearability of wire rope slings.
- Can be used to connect *HIGH STRENGTH* Synthetic Web Slings, *HIGH STRENGTH* Synthetic Round Slings or Wire Rope Slings.
- Increase in shackle bow radius provides minimum 58% gain in sling bearing surface and eliminates need for a thimble.
- Increases usable sling strength minimum of 15%.
- Pin is non-rotating, with weld on handle for easier use.
- All ratings are in metric tons, embossed on side of bow.
- Forged alloy steel from 75 through 300 metric tons.
- Cast alloy steel from 400 through 1000 metric tons.
- Sizes 400 tons and larger are tested to 1.33 times Working Load Limit.
- Sizes 300 tons and smaller are proof tested to 2 times the Working Load Limit.
- All 2160 shackles are individually proof tested, Crosby certification available at time of order. Shackles requiring ABS, DNV, Lloyds and other certifications are available upon special request and must be specified at time of order.
- Shackles are produced in accordance with certified lifting appliance requirements.
 - Non Destructive Testing
 - Serialization / Identification
 - Material Testing (Physical / Chemical / Charpy)
 - Proof Testing
- All sizes Quenched and Tempered for maximum strength.
- Bows and pins are furnished Dimetcoated. All pins are Dimetcoated then painted red.
- Type Approval and certification in accordance with DNV Specification 2.7-1 Offshore Containers and DNV rules for Lifting Appliances-Loose Gear.



Load Rated

NOTICE: All shackles are magnetic particle inspected.

Working Load Limit* (metric tons)	CERTEX Cat. Ref. No.	Crosby G-2160 Stock No.	Weight Each (lbs.)	Dimensions (in.)											
				A	B +/- .25	C	D +/- .02	E	G	H	J	K	P	R	
† 30	—	1021575	25	7.69	2.37	1.38	1.63	3.50	1.75	6.94	3.13	2.50	8.50	11.38	
† 40	—	1021584	35	9.28	2.88	1.69	2.01	4.00	2.31	8.06	3.75	3.00	10.62	13.62	
† 55	—	1021593	71	10.36	3.25	2.00	2.28	4.63	2.63	9.36	4.50	3.50	12.26	15.63	
† 75	CX10-0214	1021290	99	14.37	4.13	2.12	2.75	5.00	2.50	11.53	4.75	3.64	12.28	18.41	
† 125	CX10-0215	1021307	161	16.51	5.12	2.56	3.15	5.71	3.15	14.36	5.91	4.33	15.96	22.65	
† 200	CX10-0216	1021316	500	20.67	5.91	3.35	4.12	7.28	4.33	18.90	8.07	5.41	19.49	29.82	
† 300	CX10-0217	1021325	811	24.02	7.38	4.00	5.25	9.25	5.38	23.63	10.38	6.31	23.38	37.26	
†† 400	CX10-0218	1021334	1041	30.06	8.66	5.16	6.30	11.81	6.30	22.64	12.60	7.28	27.17	38.78	
†† 500	CX10-0219	1021343	1378	32.99	9.84	5.73	7.09	13.39	6.69	24.81	13.39	8.86	31.10	42.72	
†† 600	CX10-0220	1021352	1833	35.39	10.83	6.04	7.87	13.78	7.28	27.56	14.57	9.74	34.06	47.24	
†† 700	CX10-0221	1021361	2446	38.91	11.81	6.59	8.46	14.80	7.87	28.94	15.75	10.63	37.01	50.18	
†† 800	CX10-0222	1021254	3016	43.50	12.80	7.30	9.06	16.54	8.27	29.53	16.54	10.92	38.39	52.09	
†† 900	CX10-0223	1021389	3436	43.60	13.78	7.78	9.84	16.93	8.66	29.82	17.32	11.52	40.35	54.04	
†† 1000	CX10-0224	1021370	4022	45.98	14.96	8.33	10.63	17.72	9.06	29.92	18.11	12.11	45.32	55.31	
†† 1250	CX10-0225	1021372	5706	49.86	16.93	9.15	11.81	21.00	10.43	36.61	20.87	12.70	46.26	65.35	

* Ultimate Load is 5 times the Working Load Limit.

† Forged Alloy Steel. Proof Load is 2 times the Working Load Limit.

†† Cast Alloy Steel. Proof Load is 1.33 times the Working Load Limit.

HOIST RING

The Crosby Group, Inc.

Warnings and Application Instructions

WRONG



Figure 1

WRONG



Figure 2

External Inspection Points

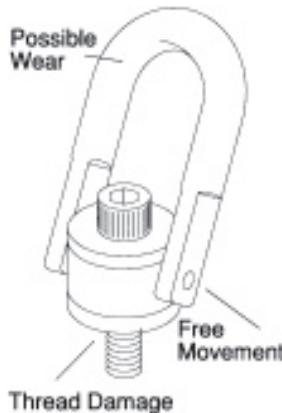

Figure 3

RIGHT

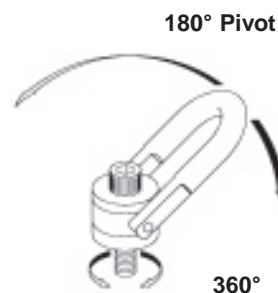

Figure 4

Hoist Ring Application Assembly Safety

- Use swivel hoist ring only with ferrous metal (steel, iron) or soft metal (i.e., aluminum) loads (work piece). Do not leave threaded end of hoist ring in aluminum loads for long time periods due to corrosion.
- After determining the loads on each hoist ring, select the proper size hoist ring using the Working Load Limit ratings in Table 1 for UNC threads and Table 2 for Metric threads.
- Drill and tap the work piece to the correct size to a minimum depth of one-half the threaded shank diameter plus the threaded shank length. See rated load limit and bolt torque requirements imprinted on top of the swivel trunnion. (See Table 1 and/or Table 2)
- Install hoist ring to recommended torque with a torque wrench making sure the bushing flange meets the load (work piece) surface.
- Never use spacers between bushing flange and mounting surface.
- Always select proper load rated lifting device for use with Swivel Hoist Ring.
- Attach lifting device ensuring free fit to hoist ring bail (lifting ring). (Fig. 1)
- Apply partial load and check proper rotation and alignment. There should be no interference between load (work piece) and hoist ring bail. (Fig. 2)
- **Special Note:** When a Hoist Ring is installed with a retention nut, the nut must have full thread engagement and must meet one of the following standards to develop the Working Load Limit (WLL).

1. ASTM A-563 (A) Grade D Hex Thick
(B) Grade DH Standard Hex
2. SAE Grade 8 — Standard Hex

Hoist Ring Inspection/Maintenance

- Always inspect hoist ring before use.
- Regularly inspect hoist ring parts. (Fig. 3)
- Never use hoist ring that show signs of corrosion, wear or damage.
- Never use hoist ring if bail is bent or elongated.
- Always be sure threads on shank and receiving holes are clean, not damaged, and fit properly.
- Always check with torque wrench before using an already installed hoist ring.
- Always make sure there are no spacers (washers) used between bushing flange and the mounting surface. Remove any spacers (washers) and retorque before use.
- Always ensure free movement of bail. The bail should pivot 180° and swivel 360°. (Fig. 4)
- Always be sure total work piece surface is in contact with hoist ring bushing mating surface. Drilled and tapped hole must be 90° to load (work piece) surface.



WARNING

- Loads may slip or fall if proper Hoist Ring assembly and lifting procedures are not used.
- A falling load may cause serious injury or death.
- Use only genuine Crosby parts as replacements.
- Read, understand and follow all instructions, diagrams and chart information before using swivel hoist ring assembly.

HOIST RING

The Crosby Group, Inc.

Warnings and Application Instructions

Wrong

Do not reeve slings from one bail to another. This will alter the load and angle of loading on the hoist ring.

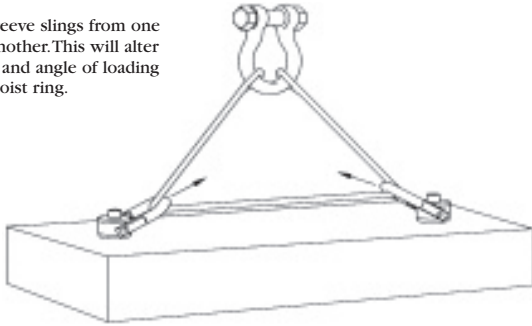

After slings have been properly attached to the hoist ring, apply force slowly. Watch the load and be prepared to stop applying force if the load starts buckling.

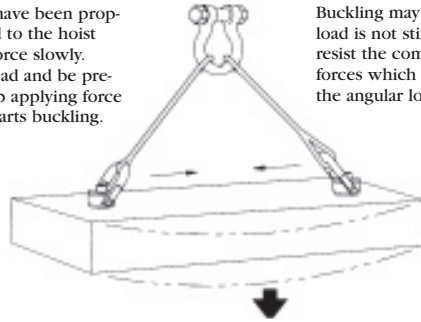

Buckling may occur if the load is not stiff enough to resist the compressive forces which result from the angular loading.

OPERATING SAFETY

- Never exceed the capacity of the swivel hoist ring, see Table 1 for UNC threads and Table 2 for Metric threads.

- When using lifting slings of two or more legs, make sure the forces in the legs are calculated using the angle from the vertical to the leg and select the proper size swivel hoist ring to allow for the angular forces. (Note: Sling angles will de-rate sling members (chain, rope, or webbing) but will not de-rate swivel hoist ring capacity.)

WARNING



- Loads may slip or fall if proper Hoist Ring assembly and lifting procedures are not used.
- A falling load may cause serious injury or death.
- Use only genuine Crosby parts as replacements.
- Read, understand and follow all instructions, diagrams and chart information before using swivel hoist ring assembly.

10

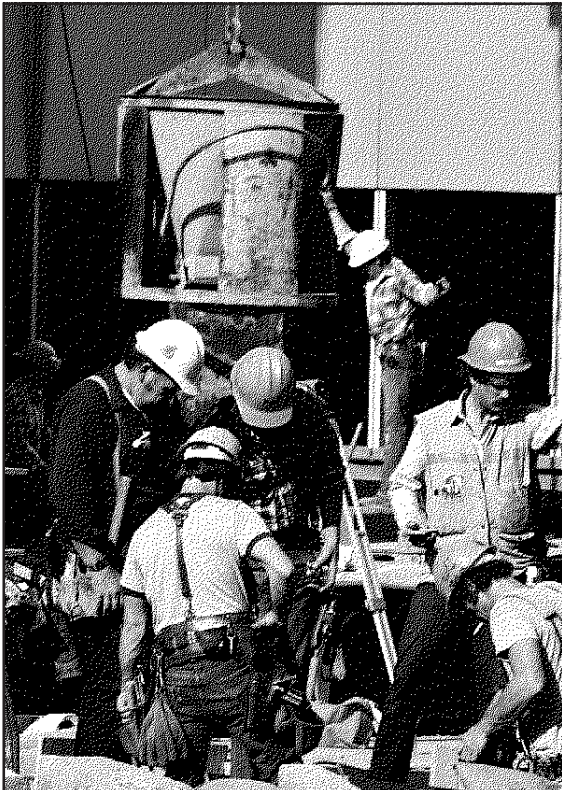

Dependability In Lifting- Everywhere, Every Time.

You're in a tough lifting situation. Valuable equipment and the lives of your workers are on the line. You have to meet deadlines, observe regulations and stay within a budget. The slightest overlooked detail can put employees and valuable equipment in harm's way. Are you sure you have every detail covered?

When you're taking on the weight of the world, turn to CERTEX, the lifting experts, for the

experience and resources to make your most complex lifting challenge like just another day at the office.

CERTEX puts its world-wide network into the hands of local companies who know your needs and are close at hand to serve you.

CERTEX
Lifting Products and Services

HOIST RING

The Crosby Group, Inc.

Warnings and Application Instructions

Table 1			
HR-125 Swivel Hoist Rings			
Working Load Limit* (lbs.)	Torque** in Ft. Lbs.	Bolt Size†† (in.)	Effective Thread Projection Length (in.)
800†	7	5/16 - 18 x 1.50	.59
1000†	12	3/8 - 16 1.50	.59
2500	28	1/2 - 13 x 2.00	.71
2500†	28	1/2 - 13 x 2.50	1.21
4000	60	5/8 - 11 x 2.00	.71
4000†	60	5/8 - 11 x 2.75	1.46
5000	100	3/4 - 10 x 2.25	.96
5000†	100	3/4 - 10 x 2.75	1.46
7000	100	3/4 - 10 x 2.75	.90
7000†	100	3/4 - 10 x 3.50	1.65
8000	160	7/8 - 9 x 2.75	.90
8000†	160	7/8 - 9 x 3.50	1.65
10000	230	1 - 8 x 4.00	1.15
10000†	230	1-1/4 - 7 x 4.50	2.15
15000	470	1-1/2 - 6 x 6.50	2.22
24000	800	1-1/2 - 6 x 6.50	2.98
30000	1100	2 - 4-1/2 x 6.50	2.98

* Ultimate load is 5 times the Working Load Limit. Individually proof tested to 2 1/2 times the Working Load Limit.

** The tightening torque values shown are based upon threads being clean, dry and free of lubrication.

† Long bolts are designed to be used with soft metal (i.e., aluminum) work piece. While the long bolts may also be used with ferrous metal (i.e., steel & iron) work pieces, short bolts are designed for ferrous work pieces only.

†† Bolt specification is a Grade 8 Alloy socket head cap screw to ASTM A 574. All threads are UNC - 3A.

Table 1				
HR-125M Metric Swivel Hoist Rings*				
Working Load Limit (Kg)		Torque** in N-m	Bolt Size†† (mm)	Effective Thread Projection Length (mm)
At a 5:1 Design Factor†	At a 4:1 Design Factor†			
400	500	10	M 8 x 1.25 x 40	16.9
450	550	16	M 10 x 1.50 x 40	16.9
1050	1300	38	M 12 x 1.75 x 50	17.2
1900	2400	81	M 16 x 2.00 x 60	27.2
2150	2700	136	M 20 x 2.50 x 65	31.2
3000	3750	136	M 20 x 2.50 x 75	28.1
4200	5250	312	M 24 x 3.00 x 80	33.1
7000	8750	637	M 30 x 3.50 x 100	45.1
11000	13750	1005	M 36 x 4.00 x 150	60.6
12500	15600	1005	M 42 x 4.50 x 160	70.6
13500	16900	1350	M 48 x 5.00 x 160	70.6

* Designed to be used with ferrous work piece only.

** The tightening torque values shown are based upon threads being clean, dry and free of lubrication.

† Individually proof tested to 2 1/2 times the Working Load Limit based on the 4:1 design factor.

†† Bolt specification is a Grade 12.9 Alloy socket head cap screw to DIN 912.

All threads are metric (ASME/ANSI B18.3.1m).

WARNING



- Loads may slip or fall if proper Hoist Ring assembly and lifting procedures are not used.
- A falling load may cause serious injury or death.
- Use only genuine Crosby parts as replacements.
- Read, understand and follow all instructions, diagrams and chart information before using swivel hoist ring assembly.

HOIST RING

The Crosby Group, Inc.

UNC Threads

Top washer has the following features:

- The Working Load Limit and Recommended Torque value are permanently stamped into each washer.
- Washer is color coded for easy identification

Red - UNC thread

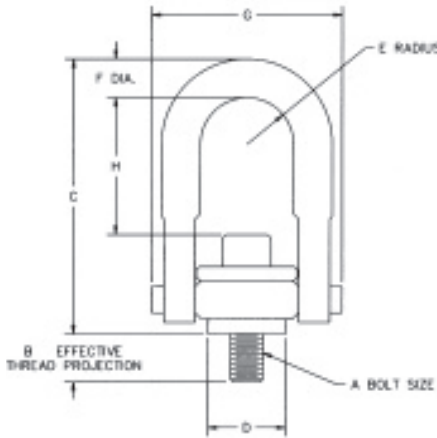

BOLT SIZE IDENTIFICATION

The size of the bolt will be stated as in the following example. Illustration shows meaning of each dimension given.

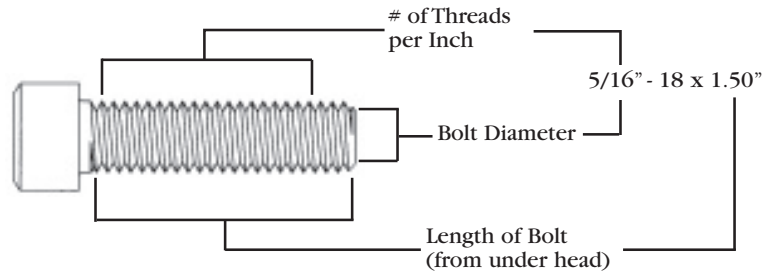

CERTEX Cat. Ref. No.	Crosby HR-125 Stock No.	Working Load Limit* (lbs.)	Torque in Ft. Lbs.	Dimensions (in.)								Est. Weight Each (lbs.)
				Bolt Size†† A	Effective Thread Protection Length B	C	D	Radius E	Diameter F	G	H	
CX10-0225	1016887†	800	7	5/16 - 18 x 1.50	.59	2.68	1.00	.45	.38	1.75	1.11	.43
CX10-0226	1016898†	1000	12	3/8 - 16 x 1.50	.59	2.68	1.00	.45	.38	1.75	1.09	.43
CX10-0227	1016909	2500	28	1/2 - 13 x 2.00	.71	4.90	2.00	.89	.75	3.30	2.29	2.49
CX10-0228	1016912†	2500	28	1/2 - 13 x 2.50	1.21	4.90	2.00	.89	.75	3.30	2.29	2.52
CX10-0229	1016920	4000	60	5/8 - 11 x 2.00	.71	4.90	2.00	.89	.75	3.30	2.21	2.55
CX10-0230	1016924†	4000	60	5/8 - 11 x 2.75	1.46	4.90	2.00	.89	.75	3.30	2.21	2.70
CX10-0231	1016931	5000	100	3/4 - 10 x 2.25	.96	4.90	2.00	.89	.75	3.30	2.05	2.65
CX10-0232	1016935†	5000	100	3/4 - 10 x 2.75	1.46	4.90	2.00	.89	.75	3.30	2.05	3.00
CX10-0233	1016942	7000	100	3/4 - 10 x 2.75	.90	6.58	3.00	1.40	1.00	4.80	2.98	7.00
CX10-0234	1016946†	7000	100	3/4 - 10 x 3.50	1.65	6.58	3.00	1.40	1.00	4.80	2.98	7.00
CX10-0235	1016953	8000	160	7/8 - 9 x 2.75	.90	6.58	3.00	1.40	1.00	4.80	2.95	7.00
CX10-0236	1016957†	8000	160	7/8 - 9 x 3.50	1.65	6.58	3.00	1.40	1.00	4.80	2.95	7.00
CX10-0237	1016964	10000	230	1 - 8 x 3.00	1.15	6.58	3.00	1.40	1.00	4.80	2.73	7.50
CX10-0238	1016969†	10000	230	1 - 8 x 4.00	2.15	6.58	3.00	1.40	1.00	4.80	2.73	7.50
CX10-0239	1016975	15000	470	1 1/4 - 7 x 4.50	2.22	9.01	3.75	1.75	1.25	6.00	4.89	14.79
CX10-0240	1016986	24000	800	1 1/2 - 6 x 6.50	2.98	12.41	4.75	2.25	1.75	8.00	5.93	33.00
CX10-0241	1016997	30000	1100	2 - 4 1/2 x 6.50	2.98	12.41	4.75	2.25	1.75	8.00	5.43	36.00

* Ultimate load is 5 times the Working Load Limit.

Long bolts are designed to be used with soft metal (i.e., aluminum) work piece. While the long bolts may also be used with ferrous metal (i.e., steel & iron) work piece, short bolts are designed for ferrous work pieces only.

†† Bolt specification is a Grade 8 Alloy socket head cap screw to ASTM A 574. All threads listed are UNC - 3A.



EYE BOLTS

The Crosby Group, Inc.

Warnings and Application Instructions



Regular Nut
Eye Bolt
G-291



Shoulder Nut
Eye Bolt
G-277



Machinery Nut
Eye Bolt
S-279

Table 1 (In-Line Load)	
Size (in.)	Working Load Limit (lbs.)
1/4	650
5/16	1200
3/8	1550
1/2	2600
5/8	5200
3/4	7200
7/8	10600
1	13300
1 1/4	21000
1 1/2	24000

IMPORTANT SAFETY INFORMATION — READ & FOLLOW

Inspection/Maintenance Safety:

- Always inspect eye bolt before use.
- Never use eye bolt that shows signs of wear or damage.
- Never use eye bolt if eye or shank is bent or elongated.
- Always be sure threads on shank and receiving holes are clean.
- Never machine, grind, or cut eye bolt.

Assembly Safety:

- Never exceed load limits specified in Table I.
- Never use regular nut eye bolts for angular lifts.
- Always use shoulder nut eye bolts (or machinery eye bolts) for angular lifts.
- For angular lifts, adjust working load as follows:

Direction of Pull	Adjusted Working Load
45 degrees	30% of rated working load
90 degrees	25% of rated working load

- Never undercut eye bolt to seat shoulder against the load.
- Always countersink receiving hole or use washers to seat shoulder.
- Always screw eye bolt down completely for proper seating.
- Always tighten nuts securely against the load.

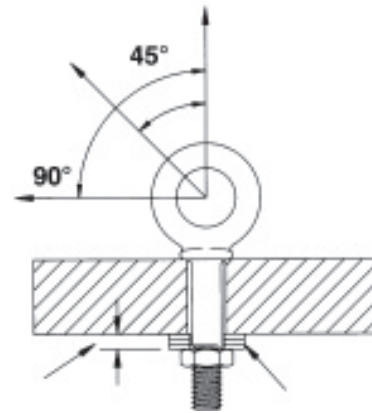

IN - LINE

Shoulder Nut Eye Bolt — Installation for Angular Loading

- The threaded shank must protrude through the load sufficiently to allow full engagement of the nut.
- If the eye bolt protrudes so far through the load that the nut cannot be tightened securely against the load, use properly sized washer to take up the excess space BETWEEN THE NUT AND THE LOAD.
- Place washers or spacers between nut and load so that when the nut is tightened securely, the shoulder is secured flush against the load surface.
- Thickness of spacers must exceed this distance between the bottom of the load and the last thread of the eye bolt.



WARNING

- Loads may slip or fall if proper eye bolt assembly and lifting procedures are not used.
- A falling load can serious injury or kill.
- Read and understand both sides of these instructions, and follow all eye bolt safety information presented here.
- Read, understand and follow all information in diagrams and charts below before using eye bolt assemblies.

EYE BOLTS

The Crosby Group, Inc.

Warnings and Application Instructions

Regular Nut & Shoulder Nut Eye Bolt – Installation for In-line Loading

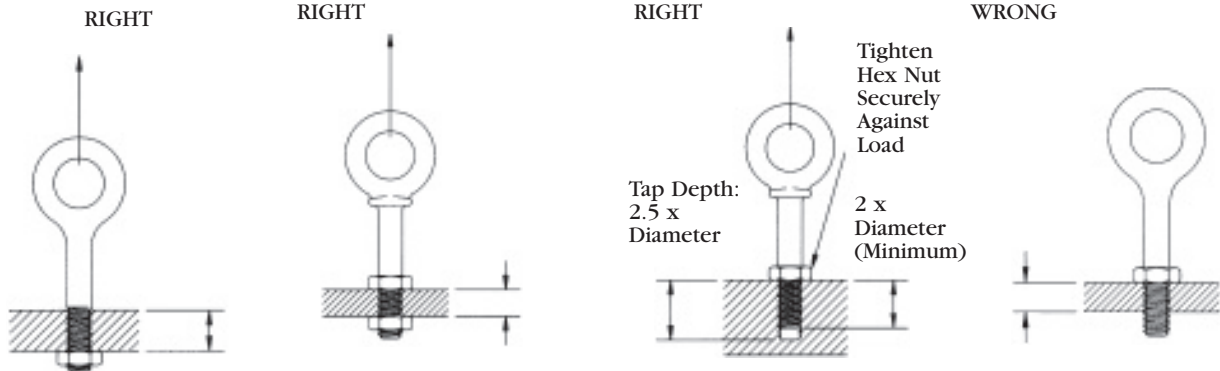

More than one eye bolt diameter of threads, only (1) nut required. Tighten hex nut securely against load

One eye bolt diameter of threads or less, use two (2) nuts. Tighten hex nut securely against load

One eye bolt diameter or less

Operating Safety

- Always stand clear of load.
- Always lift load with steady, even pull - do not jerk.
- Always apply load to eye bolt in the plane of the eye - not at an angle.
- Never exceed the capacity of the eye bolt-see Table 1.
- When using lifting slings of two or more legs, make sure the loads in the legs are calculated using the angle from the vertical to the leg and properly size the shoulder nut or machinery eye bolt for the angular load.

WRONG

Do not reeve slings from one eye bolt to another. This will alter the load and angle of loading on the eye bolt.

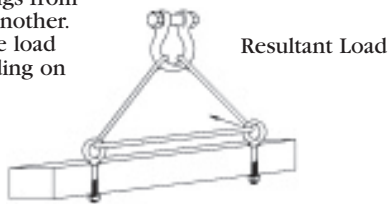

After slings have been properly attached to the eye bolts, apply force slowly. Watch the load carefully and be prepared to stop applying force if the load starts buckling.

Buckling may occur if the load is not stiff enough to resist the compressive forces which result from the angular loading.

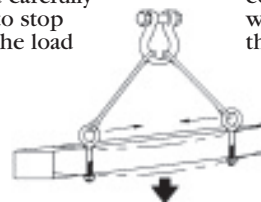

10

WARNING

- Loads may slip or fall if proper eye bolt assembly and lifting procedures are not used.
- A falling load can serious injury or kill.
- Read and understand both sides of these instructions, and follow all eye bolt safety information presented here.
- Read, understand and follow all information in diagrams and charts below before using eye bolt assemblies.



EYE BOLTS

The Crosby Group, Inc.

Warnings and Application Instructions

Machinery Eye Bolt — Installation for In - line & Angular Loading

These eye bolts are primarily intended to be installed into tapped holes.

1. After the loads on the eye bolts have been calculated, select the proper size eye bolt for the job.

For angular lifts, adjust working load as follows:

Direction of Pull	Adjusted Working Load
45 degrees	30% of rated working load
90 degrees	25% of rated working load

2. Drill and tap the load to the correct sizes to a minimum depth of one-half the eye bolt size beyond the shank length of the machinery eye bolt.
3. Thread the eye bolt into the load until the shoulder is flush and securely tightened against the load.
4. If the plane of the machinery eye bolt is not aligned with the sling line, estimate the amount of unthreading rotation necessary to align the plane of the eye properly.
5. Remove the machinery eye bolt from the load and add shims (washers) of proper thickness to adjust the angle of the plane of the eye to match the sling line. Use Table II to estimate the required shim thickness for the amount of unthreading rotation required.

Eye Bolt Size (in.)	Shim Thickness Required to Change Rotation 90° (in.)
1/4	.0125
5/16	.0139
3/8	.0156
1/2	.0192
5/8	.0227
3/4	.0250
7/8	.0278
1	.0312
1 1/4	.0357
1 1/2	.0417

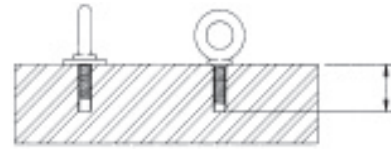

Shim added to change eye alignment 90°
Minimum tap depth is basic shank length plus one-half the nominal eye bolt diameter.

CERTEX

The New Standard In Lifting Products and Services.

In the field of lifting, CERTEX means certainty. From simple, straight forward hardware and custom-made assemblies, to complete lifting management programs, the name CERTEX represents quality, safety, service and expertise. CERTEX companies are your trusted local source

for lifting products and services, backed by world-wide experience and expertise to solve any lifting problem.

Wherever people are at work building, producing and moving the world's goods, CERTEX means certainty.

EYE BOLTS

The Crosby Group, Inc.

Shoulder Type Machinery Eye Bolts



S-279

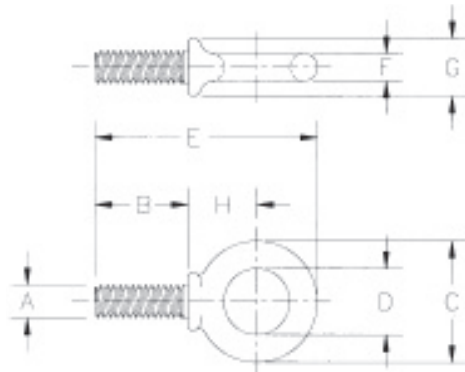

- Forged Steel — Quenched & Tempered.
- Recommended for straight line pull.
- Fatigue tested to 1 1/2 times the Working Load Limit for 20,000 cycles.

Size	CERTX Cat. Ref. No.	Crosby Stock No.	Working Load Limit* (lbs.)	Weight per 100 (lbs.)	Dimensions (in.)							
					A	B	C	D	E	F	G	H
1/4 x 1	CX10-0313	9900182	650	5.10	.25	1.00	.88	.50	1.94	.19	.47	.50
5/16 x 1 1/8	CX10-0314	9900191	1200	6.20	.31	1.13	1.12	.62	2.38	.25	.56	.69
3/8 x 1 1/4	CX10-0315	9900208	1550	12.50	.38	1.25	1.38	.75	2.72	.31	.66	.78
1/2 x 1 1/2	CX10-0316	9900217	2600	25.00	.50	1.50	1.75	1.00	3.38	.38	.91	1.00
5/8 x 1 3/4	CX10-0317	9900226	5200	50.00	.63	1.75	2.25	1.25	4.19	.50	1.12	1.31
3/4 x 2	CX10-0318	9900235	7200	87.50	.75	2.00	2.75	1.50	4.94	.62	1.38	1.56
7/8 x 2 1/4	CX10-0319	9900244	10600	157.20	.88	2.25	3.25	1.75	5.72	.75	1.56	1.84
1 x 2 1/2	CX10-0320	9900253	13300	218.00	1.00	2.50	3.75	2.00	6.47	.88	1.81	2.09
1 1/4 x 3	CX10-0321	9900262	21000	380.00	1.25	3.00	4.50	2.50	7.72	1.00	2.28	2.47
1 1/2 x 3 1/2	CX10-0322	9900271	24000	700.00	1.50	3.50	5.50	3.00	9.25	1.25	2.75	3.00

* Ultimate Load is 5 times the Working Load Limit.



EYE BOLTS

The Crosby Group, Inc.

Shoulder Nut Eye Bolts



G-277

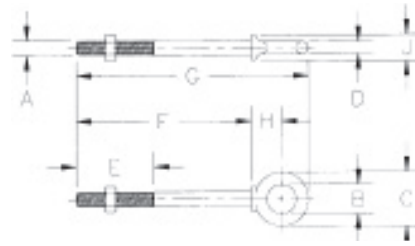

- Forged Steel.
- Hot Dip galvanized.
- Furnished with standard Hot Dip galvanized, heavy hex nuts.
- Fatigue tested to 1 1/2 times the Working Load Limit for 20,000 cycles.

Shank Diameter & Length (in.)	CERTEX Cat. Ref. No.	Crosby G-277 Stock No. Galv.	Working Load Limit * (lbs.)	Weight Per 100 (lbs.)	Dimensions (in.)									
					A	B	C	D	E	F	G	H	J	
1/4 x 2	CX10-0323	1045014	650	6.60	.25	.50	.88	.19	1.50	2.00	2.94	.50	.47	
1/4 x 4	CX10-0324	1045032	650	9.10	.25	.50	.88	.19	2.50	4.00	4.94	.50	.47	
5/16 x 2 1/4	CX10-0325	1045050	1200	12.50	.31	.62	1.12	.25	1.50	2.25	3.50	.69	.56	
5/16 x 4 1/4	CX10-0326	1045078	1200	18.80	.31	.62	1.12	.25	2.50	4.25	5.50	.69	.56	
3/8 x 2 1/2	CX10-0327	1045096	1550	21.40	.38	.75	1.38	.31	1.50	2.50	3.97	.78	.66	
3/8 x 4 1/2	CX10-0328	1045112	1550	25.30	.38	.75	1.38	.31	2.50	4.50	5.97	.78	.66	
1/2 x 3 1/4	CX10-0329	1045130	2600	42.60	.50	1.00	1.75	.38	1.50	3.25	5.12	1.00	.91	
1/2 x 6	CX10-0330	1045158	2600	56.80	.50	1.00	1.75	.38	3.00	6.00	7.88	1.00	.91	
5/8 x 4	CX10-0331	1045176	5200	68.60	.62	1.25	2.25	.50	2.00	4.00	6.44	1.31	1.12	
5/8 x 6	CX10-0332	1045194	5200	102.40	.62	1.25	2.25	.50	3.00	6.00	8.44	1.31	1.12	
3/4 x 4 1/2	CX10-0333	1045210	7200	144.50	.75	1.50	2.75	.62	2.00	4.50	7.44	1.56	1.38	
3/4 x 6	CX10-0334	1045238	7200	167.50	.75	1.50	2.75	.62	3.00	6.00	8.94	1.56	1.38	
7/8 x 5	CX10-0335	1045256	10600	225.00	.88	1.75	3.25	.75	2.50	5.00	8.46	1.84	1.56	
1 x 6	CX10-0336	1045292	13300	366.30	1.00	2.00	3.75	.88	3.00	6.00	9.97	2.09	1.81	
1 x 9	CX10-0337	1045318	13300	422.50	1.00	2.00	3.75	.88	4.00	9.00	12.97	2.09	1.81	
1 1/4 x 8	CX10-0338	1045336	21000	650.00	1.25	2.50	4.50	1.00	4.00	8.00	12.72	2.47	2.28	
1 1/4 x 12	CX10-0339	1045354	21000	795.00	1.25	2.50	4.50	1.00	4.00	12.00	16.72	2.47	2.28	
1 1/2 x 15	CX10-0340	1045372	24000	1425.00	1.50	3.00	5.50	1.25	6.00	15.00	20.75	3.00	2.75	

* Ultimate Load is 5 times the Working Load Limit.



EYE BOLTS

The Crosby Group, Inc.

Regular Nut Eye Bolts



G-291

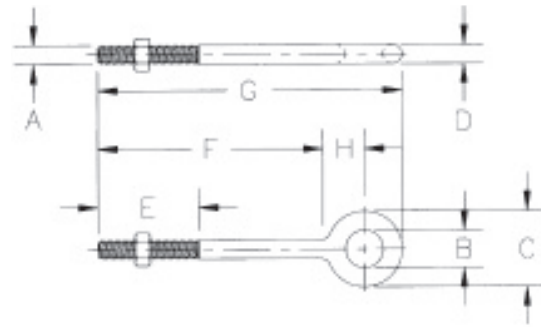

- Recommended for straight line pull.
- All Bolts Hot Dip galvanized after threading.
- Furnished with standard Hot Dip galvanized hex nuts.
- Forged Steel — Quenched and Tempered.
- Fatigue tested to 1 1/2 times the Working Load Limit for 20,000 cycles.

Shank Diameter & Length (in.)	CERTEX Cat. Ref. No.	Crosby G-291 Stock No. Galv.	Working Load Limit * (lbs.)	Weight Per 100 (lbs.)	Dimensions (in.)							
					A	B	C	D	E	F	G	H
1/4 x 2	CX10-0346	1043230	650	8.20	.25	.50	1.00	.25	1.50	2.00	3.06	.56
1/4 x 4	CX10-0347	1043258	650	11.70	.25	.50	1.00	.25	2.50	4.00	5.06	.56
5/16 x 2 1/4	CX10-0348	1043276	1200	13.30	.31	.62	1.25	.31	1.50	2.25	3.56	.69
5/16 x 4 1/4	CX10-0349	1043294	1200	25.00	.31	.62	1.25	.31	2.50	4.25	5.56	.69
3/8 x 2 1/2	CX10-0350	1043310	1550	23.30	.38	.75	1.50	.38	1.50	2.50	4.12	.88
3/8 x 4 1/2	CX10-0351	1043338	1550	29.50	.38	.75	1.50	.38	2.50	4.50	6.12	.88
3/8 x 6	CX10-0352	1043356	1550	35.20	.38	.75	1.50	.38	2.50	6.00	7.62	.88
1/2 x 3 1/4	CX10-0353	1043374	2600	50.30	.50	1.00	2.00	.50	1.50	3.25	5.38	1.12
1/2 x 6	CX10-0354	1043392	2600	66.10	.50	1.00	2.00	.50	3.00	6.00	8.12	1.12
1/2 x 8	CX10-0355	1043418	2600	82.00	.50	1.00	2.00	.50	3.00	8.00	10.12	1.12
1/2 x 10	CX10-0356	1043436	2600	88.00	.50	1.00	2.00	.50	3.00	10.00	12.12	1.12
1/2 x 12	CX10-0357	1043454	2600	114.20	.50	1.00	2.00	.50	3.00	12.00	14.12	1.12
5/8 x 4	CX10-0358	1043472	5200	103.10	.62	1.25	2.50	.62	2.00	4.00	6.69	1.44
5/8 x 6	CX10-0359	1043490	5200	118.20	.62	1.25	2.50	.62	3.00	6.00	8.69	1.44
5/8 x 8	CX10-0360	1043515	5200	135.10	.62	1.25	2.50	.62	3.00	8.00	10.69	1.44
5/8 x 10	CX10-0361	1043533	5200	153.60	.62	1.25	2.50	.62	3.00	10.00	12.69	1.44
5/8 x 12	CX10-0362	1043551	5200	167.10	.62	1.25	2.50	.62	4.00	12.00	14.69	1.44
3/4 x 4 1/2	CX10-0363	1043579	7200	168.60	.75	1.50	3.00	.75	2.00	4.50	7.69	1.69
3/4 x 6	CX10-0364	1043597	7200	184.50	.75	1.50	3.00	.75	3.00	6.00	9.19	1.69
3/4 x 8	CX10-0365	1043613	7200	207.90	.75	1.50	3.00	.75	3.00	8.00	11.19	1.69
3/4 x 10	CX10-0366	1043631	7200	235.00	.75	1.50	3.00	.75	3.00	10.00	13.19	1.69
3/4 x 12	CX10-0367	1043659	7200	257.50	.75	1.50	3.00	.75	4.00	12.00	15.19	1.69
3/4 x 15	CX10-0368	1043677	7200	298.00	.75	1.50	3.00	.75	5.00	15.00	18.19	1.69
7/8 x 5	CX10-0369	1043695	10600	270.00	.88	1.75	3.50	.88	2.50	5.00	8.75	2.00
7/8 x 8	CX10-0370	1043711	10600	308.00	.88	1.75	3.50	.88	4.00	8.00	11.75	2.00
7/8 x 12	CX10-0371	1043739	10600	400.00	.88	1.75	3.50	.88	4.00	12.00	15.75	2.00
1 x 6	CX10-0372	1043757	13300	421.00	1.00	2.00	4.00	1.00	3.00	6.00	10.31	2.31
1 x 9	CX10-0373	1043775	13300	468.50	1.00	2.00	4.00	1.00	4.00	9.00	13.31	2.31
1 x 12	CX10-0374	1043793	13300	540.00	1.00	2.00	4.00	1.00	4.00	12.00	16.31	2.31
1 x 18	CX10-0375	1043819	13300	650.00	1.00	2.00	4.00	1.00	7.00	18.00	22.31	2.31
1 1/4 x 8	CX10-0376	1043837	21000	750.00	1.25	2.50	5.00	1.25	4.00	8.00	13.38	2.88
1 1/4 x 12	CX10-0377	1043855	21000	900.00	1.25	2.50	5.00	1.25	4.00	12.00	17.38	2.88
1 1/4 x 20	CX10-0378	1043873	21000	1210.00	1.25	2.50	5.00	1.25	6.00	20.00	25.38	2.88

*Ultimate Load is 5 times the Working Load Limit.



EYE BOLTS

The Crosby Group, Inc.

Shoulder Nut Ring Bolts

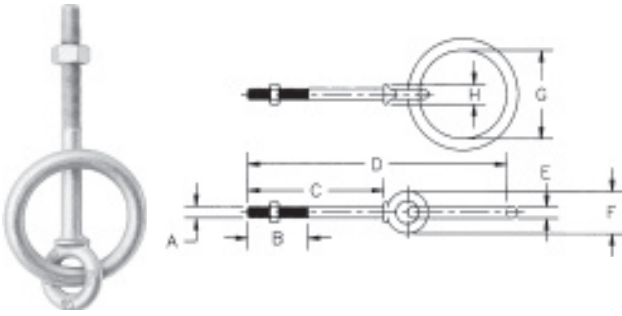

- Forged Steel — Quenched and Tempered.
- Diameter of ring stock is same as shank diameter.
- Hot Dip galvanized.

G-257

Ring Bolt Size (in.)	CERTEX Cat. Ref. No.	Crosby G-257 Stock No. Galv.	Working Load Limit* (lbs.)	Weight Per 100 (lbs.)	Dimensions (in.)							
					A	B	C	D	E	F	G	H
3/8 x 4 1/2	CX10-0379	1046335	1200	56.60	.38	2.50	4.50	7.66	.38	1.38	2.00	.66
1/2 x 6	CX10-0380	1046371	2200	100.00	.50	3.00	6.00	10.00	.50	1.75	2.50	.91

* Ultimate load is 5 times the Working Load Limit.

Pad Eyes



- Forged Steel — Quenched and Tempered.
- Forged from 1035 Carbon Steel.
- Excellent welding qualities.
- Widely used on farm machinery, trucks, steel hulled marine vessels and material handling equipment.
- Reference American Welding Society specifications for proper welding procedures.

S-264

Size No.	CERTEX Cat. Ref. No.	Crosby S-264 Stock No. S.C.	Weight Per 100 (lbs.)	Dimensions (in.)						
				B	C	D	E	G	H	L
*0	CX10-0381	1090722	2.80	.25	.19	.63	.31	.63	.09	.75
*1	CX10-0382	1090740	6.50	.38	.25	.88	.41	.88	.13	1.03
*1 1/2	CX10-0383	1090768	10.40	.63	.25	1.00	.44	1.13	.16	1.31
2	CX10-0384	1090786	21.10	.75	.38	1.06	.50	1.50	.19	1.63
4	CX10-0385	1090802	52.20	1.00	.56	1.44	.78	2.13	.22	2.34
5	CX10-0386	1090820	82.50	1.25	.69	1.75	.81	2.63	.25	2.75

* Meets the requirements of Military Specification MS-51930A

EYE BOLTS

The Crosby Group, Inc.

Eye Nuts



G-400

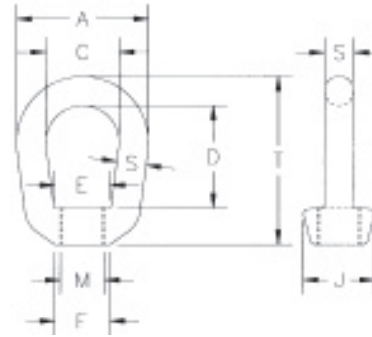

- Forged Steel — Quenched and Tempered.
- Threaded.
- Hot Dip galvanized.
- Tapped with standard UNC class 2 thread.

Size No.	Stock Size (in.) S	CERTEX Cat. Ref. No.	Crosby G-400 Stock No. Galv.	Std. Tap Size	Max. Tap Size	Working Load Limit* (lbs.)	Weight Each (lbs.)	Dimensions (in.)							
								A	C	D	E	F	J	M	T
1	.25	CX10-0387	1090438	1/4	3/8	520	.09	1.25	.75	1.06	.66	.50	.69	.25	1.69
2	.31	CX10-0388	1090474	3/8	7/16	1250	.17	1.63	1.00	1.25	.75	.56	.81	.38	2.06
3A	.38	CX10-0389	1090517	1/2	1/2	2250	.28	2.00	1.25	1.50	1.00	.81	1.00	.50	2.50
4	.50	CX10-0390	1090535	5/8	3/4	3600	.60	2.50	1.50	2.00	1.19	1.00	1.31	.63	3.19
5	.63	CX10-0391	1090553	3/4	7/8	5200	1.00	3.00	1.75	2.38	1.38	1.13	1.50	.75	3.88
6	.75	CX10-0392	1090571	7/8	1	7200	1.65	3.50	2.00	2.63	1.63	1.31	1.88	.88	4.31
7	.88	CX10-0393	1090599	1	1 1/4	10000	2.69	4.00	2.25	3.06	1.88	1.56	2.13	1.00	5.00
8	1.00	CX10-0394	1090633	1 1/4	1 1/2	15500	3.87	4.50	2.50	3.50	1.94	1.88	2.38	1.25	5.75
9	1.13	CX10-0395	1090651	1 3/8	1 1/2	18500	5.00	5.00	2.75	3.75	2.00	2.00	2.56	1.38	6.25
10	1.25	CX10-0396	1090679	1 1/2	1 3/4	22500	6.78	5.63	3.13	4.00	2.38	2.25	3.00	1.50	6.75
11	1.50	CX10-0397	1090697	2	2 3/4	40000	14.60	7.00	4.00	6.25	4.00	3.38	4.00	2.00	10.00

* Ultimate Load is 5 times the Working Load Limit. Rating based on standard tap size.

LIFTING POINTS

RUD STARPOINT – VRS-F SWIVEL EYE BOLT

Type UNC	CERTEX Cat. Ref. No.	RUD No.	WLL lbs.	M	A	B	C	D	E	L
VRS-F 1/2-13UNC		8501003	1650	1/2	1-5/8	1/2	3/8	1-3/16	1-3/16	23/32
VRS-F 1/2-13UNC		8501004	3300	5/8	1-15/16	9/16	9/16	1-3/8	1-3/8	15/16
VRS-F 1/2-13UNC		8501005	5070	3/4	2-1/4	11/16	11/16	1-9/16	1-9/16	1-3/16
VRS-F 1/2-13UNC		8501006	5070	7/8	2-1/4	11/16	11/16	1-9/16	1-9/16	1-1/4
VRS-F 1/2-13UNC		8501007	7050	1	2-3/4	13/16	13/16	1-7/8	1-7/8	1-13/32
VRS-F 1/2-13UNC		8501008	9920	1-1/4	3-3/8	1	1	2-3/8	2-3/8	1-3/4

Metric Sizes (mm)

Type metric	CERTEX Cat. Ref. No.	RUD No.	WLL t	M	A	B	C	D	E	L
VRS-F M10		7982213	0.4	10	34	11	8.5	25	25	15
VRS-F M12		7982214	0.75	12	42	13	10	30	30	18
VRS-F M16		7982215	1.5	16	49	15	14	35	35	24
VRS-F M20		7982216	2.3	20	57	17	16	40	40	30
VRS-F M24		7982217	3.2	24	69	21	19	48	48	36
VRS-F M30		7982218	4.5	30	86	26	24	60	60	48
VRS-F M36		7984201	7	36	103	32	29	72	75	54
VRS-F M42		7984202	9	42	120	38	34	82	85	63
VRS-F M48		7984203	12	48	137	43	38	94	100	72

*Nominal WLL

Box quantities

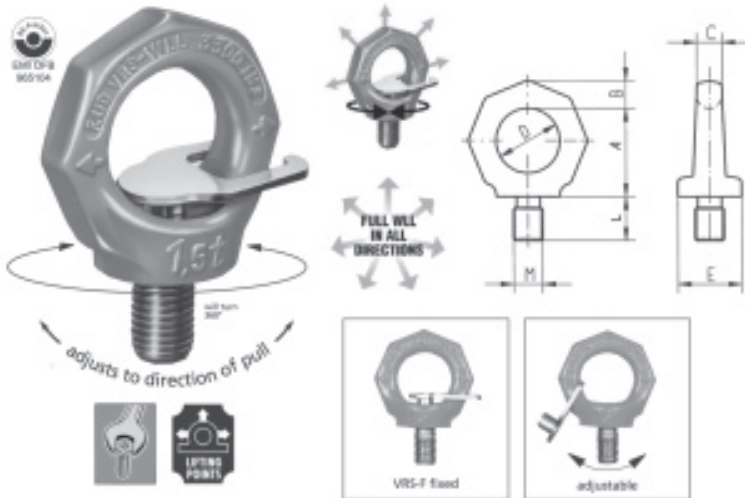

Attention: Lateral forces with standard eyebolts acc. to DIN 580 are forbidden!

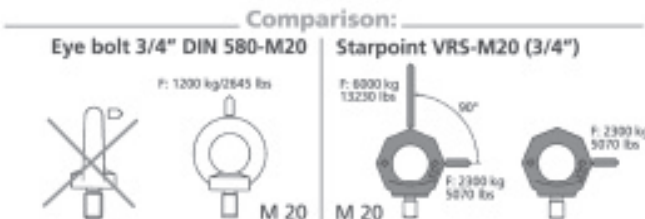

The StarPoint® is the perfect solution to eliminate the unsafe and rigid style eye bolt.

- Safety factor 4:1 in any direction.
- Marked working load limits (WLL) are rated at 90° from thread.
- Clear indication of working load limit in metric tons and lbs. for side loading applications.
- Forged material (1.6541) alloy quenched and tempered.
- The Distinct Florescent pink powder-coating changes its color when temperatures exceed 200°C. If the StarPoint® reaches temperatures of 400°C, the color changes to a deep black with small bubbles, indication that it has been over-heated.
- Body and bolt, 100% electromagnetic alloy crack tested in accordance with specification EN 1677.
- The StarPoint® is supplied with an annealed star-profile-key. Simply engage the Hexagon socket bolt with the star-profile-key and use your fingers to respectively tighten or untighten the arrangement. Disengage the key.
- The StarPoint® is rotatable!

LIFTING POINTS

RUD PowerPoint Star



The first generation of lifting points with a double ball bearing which enables jerk - free turning, swiveling and tilting. PP-S is designed with a universal connection for every lifting appliance (hook and ring assemblies, round slings, loops endless slings etc.)

- Optimized design prevents the lifting points as well as the load from being damaged

- Tested design factor 4:1 in any direction
- Cr Ni Mo Steel, Quenched and tempered
- Double Ball bearing for smooth tilting and turning
- Maximum WLL with the smallest thread diameter

- Can be turned in a 90° position from the bolt center line
- Not suitable for permanent swiveling under full load
- Body and bolt, 100% electromagnetic alloy crack tested in accordance with specification EN 1677
- Surface: pink powder coated

PowerPoint-Star

NOTE: RUD Lifting Points are also available in metric sizes

Type	CERTEX Cat. Ref. No.	RUD No.	WLL lbs.	M	A	C	T
PP-S – 0.63t-1/2 – 13UNC		79890720	1385	1/2	1/2	23/32	4-9/16
PP-S – 1.5t-5/8 – 11UNC		7989908	3300	5/8	13/16	1	5-3/4
PP-S – 2.5t-3/4 – 10UNC		7989909	5500	3/4	17/64	1-3/16	7-23/64
PP-S – 2.5t-7/8 – 9UNC		7989910	5500	7/8	1-7/64	1-3/16	7-23/64
PP-S – 4t-1 – 8UNC		7989911	8800	1	1-13/32	1-3/8	8-15/16
PP-S – 5t-1-1/4 – 7UNC		7989912	11000	1-1/4	1-15/32	1-9/16	10-1/2
PP-S – 8t-1-1/2 – 6UNC		7989913	17600	1-1/2	1-15/16	1-13/16	12-13/64

*Nominal WLL

PowerPoint-B

Type	CERTEX Cat. Ref. No.	RUD No.	WLL lbs.	M	A	C	T
PP-B – 0.63t-1/2 – 13UNC		7989901	1385	1/2	3/8	1-3/8	4-1/8
PP-B – 1.5t-5/8 – 11UNC		7989902	3300	5/8	7/16	1-3/8	5-7/32
PP-B – 2.5t-3/4 – 10UNC		7989903	5500	3/4	1/2	1-9/16	7-5/16
PP-B – 2.5t-7/8 – 9UNC		7989904	5500	7/8	1/2	1-9/16	7-5/16
PP-B – 4t-1 – 8UNC		7989905	8800	1	5/8	1-3/4	6-3/4
PP-B – 5t-1-1/4 – 7UNC		7989906	11000	1-1/4	7/8	2-3/8	8-3/4
PP-B – 8t-1-1/2 – 6UNC		7989907	17600	1-1/2	1	2-9/16	9-1/2

*Nominal WLL

PowerPoint-VIP

Type	CERTEX Cat. Ref. No.	RUD No.	WLL lbs.	M	VIP chain connection A	F	G
PP-VIP – 0.63t-1/2 – 13UNC		7989920	1385	1/2	5/32	11/16	1-5/8
PP-VIP – 1.5t-5/8 – 11UNC		7989921	3300	5/8	15/64	15/16	2
PP-VIP – 2.5t-3/4 – 10UNC		7989922	5500	3/4	5/16	1-3/16	2-13/32
PP-VIP – 2.5t-7/8 – 9UNC		7989923	5500	7/8	5/16	1-3/16	2-13/32
PP-VIP – 4t-1 – 8UNC		7989924	8800	1	3/8	1-13/32	3-1/16
PP-VIP – 5t-1-1/4 – 7UNC		7989925	11000	1-1/4	1/2	1-13/16	3-5/8
PP-VIP – 8t-1-1/2 – 6UNC		7989926	17600	1-1/2	5/8	2-1/8	4

*Nominal WLL

VLBG-Adjustable in pull direction, turns 360°

Type	CERTEX Cat. Ref. No.	RUD No.	WLL lbs.	M	H	C	T
VLBG-Z – 1t-1/2 – 13UNC		8502349	1385	1/2	7/8	1-1/32	3
VLBG-Z – 1.5t-5/8 – 11UNC		8502350	3300	5/8	9/16	1-1/2	3-5/16
VLBG-Z – 2.5t-3/4 – 10UNC		8502351	5500	3/4	5/8	2-1/8	4-11/32
VLBG-Z – 2.5t-7/8 – 9UNC		8502352	5500	7/8	5/8	2-1/8	4-11/32
VLBG-Z – 4t-1 – 8UNC		8502353	8800	1	5/8	2-1/8	4-15/16
VLBG-Z – 5t-1-1/4 – 7UNC		8503187	11000	1-1/4	15/16	2-1/2	5-3/4

*Nominal WLL

Why are RUD-Lifting Points “PINK”?

The special fluorescent pink powder coating permanently changes color at increased temperatures. If chain reaches temperatures of 400°C, the color changes to a deep black with small bubbles, indicating that the chain has been over-heated; the chain should not be used at this high temperature.

The special fluorescent pink powder coating permanently highlights the maximum temperature at which the VIP lifting point has been used.



LIFTING POINTS

RUD

Load Ring - VLBS - for welding

4 better lifting

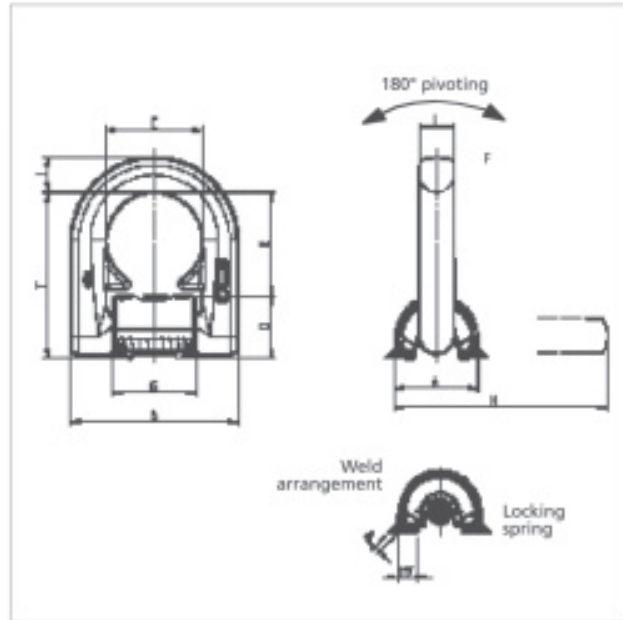

Type	CERTEX Cat. Ref. No.	RUD No. captive complete	RUD No. without spring	WLL lbs.	A	B	C	D	E	ØF	G	H	I	T	Weld	Weight lbs.
VLBS 1.5		79 93 035	79 93 115	3300	1-1/4	2-5/8	1-1/2	63/64	1-9/16	17/32	1-19/64	3-7/16	9/16	2-9/16	HV 5+3	0.77
VLBS 4		79 93 036	79 93 116	8800	1-21/32	3-27/64	2	1-1/4	2-3/64	21/32	1-13/16	4-13/32	45/64	3-16/64	HV 8+3	1.76
VLBS 6.7		79 93 037	79 93 117	14740	2-13/32	4-15/32	2-5/8	1-47/64	2-7/8	7/8	2-3/8	6-3/16	15/16	4-21/32	HV 12+4	4.18
VLBS 10		79 93 038	79 93 118	22000	2-61/64	5-5/64	2-5/8	2-5/32	2-51/64	1-3/64	2-3/8	6-13/16	1-3/64	4-31/32	HV 16+4	14.96
VLBS 16		-	79 93 041	35200	3-3/4	7-31/64	3-15/16	2-23/32	4-1/8	1-1/64	3-35/64	9-9/16	1-37/64	6-55/64	HV 25+6	14.96

- The new VLBS forged out of high tensile CrNiMo - steel with an innovative design offers many advantages.

- Up to 50% higher WLL.

- The two protective supporting lugs (inside the load ring) are patented and they improve the connection with the attachment in addition to the protected clamping spring.

- The support effect is exceptional, especially if the ring is side loaded or the lifting point is welded on an uneven work piece.

- The special fluorescent pink powder coating permanently highlights the maximum temperature at which the VIP chain has been used.

- Easy and quick to weld assemble.
- Compact and shapely design.
- High dynamic and static strength.
- Forged suspension ring acc. to EN 1677, grade 80, electromagnetic crack detected, pink powder coated; meets the requirements of the appropriate safety authorities.
- The welding block has been forged of material 1.0570 (St 52-3) and clearly stamped with the permissible WLL. The patented distance lugs assist in achieving the correct root weld.

- **Important:** By the special weld design (continuous HV), the requirements of DIN 18800 are fulfilled, i.e., a closed weld avoids corrosion and thus suitable for outdoor use.

- **Distinctive features for type LBS-U:** A protected spring maintains the load ring in every required position. The parts are assembled in such a way that they remain captive.

- The spring reduces vibration induced noise.



LIFTING POINTS

RUD

Load Ring - VRBS - for welding

4 better lifting

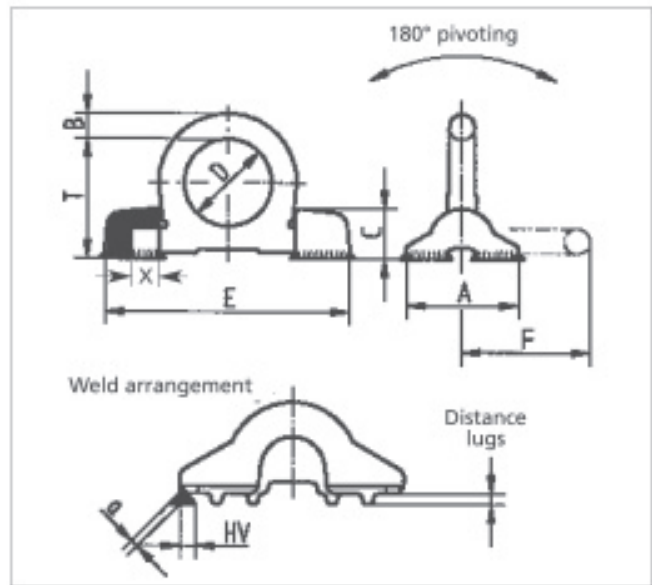

Type	CERTEX Cat. Ref. No.	RUD No. captive complete	WLL lbs.	A	B	C	D	E	F	O	Q	X	T	Weld HV + Δ _a	Weight lbs.
VRBS 4	79 92 488	8800	2-29/64	5/8	1-7/64	1-7/8	5-5/16	2-51/64	21/32	3-1/32	9/16	2-9/16	HV 4+3	1.76	
VRBS 6.7	79 92 489	14740	3/15/32	25/32	1-17/32	2-3/8	6-11/16	3-19/32	29/32	3-31/32	19/32	3-5/16	HV 5.5+3	4.62	
VRBS 10	79 92 490	22000	3-15/16	7/8	1-13/16	2-9/16	7-11/16	3-15/16	1-7/64	4-11/64	7/8	3-3/4	HV 6+4	6.16	
VRBS 16	79 92 491	35200	5-1/8	1-3/16	2-1/4	3-35/64	10-7/16	5-9/32	1-13/32	5-25/32	1-7/64	5	HV 8.5+4	14.52	
VRBS 30	60267	66000	6-19/64	1-21/32	3-5/64	5-1/8	14-49/64	7-43/64	1-55/64	8-21/32	1-29/64	7	HV 15+4	41.80	
VRBS 50	56 834	110000	9-7/16	2-3/4	4-23/32	9-1/16	24-13/32	13-3/8	2-9/16	14-31/32	-	12-21/64	HV 25+8	187.00	

- Distribution of the load force due to the 2 point fixing, hence an optimized force introduction to the work piece.
- Forged, suspension ring acc. to EN 1677-1, electromagnetic crack detected, pink power coated. Suspension ring can also be ordered single. For instance VRL 4. This lifting point fulfills the requirements of the appropriate safety authorities (German Employer's insurance Association). Stamped
- Lays flat when not in use.
- Low profile.
- Rounded well shaped design.
- High dynamic and static strength.
- The welding blocks are forged out of the ideal weldable steel ST52-3N (S355J2+N) and the nominal WLL is embossed.
- Patented distance lugs assist in achieving the correct root weld (approx. 3 mm).
- The weld arrangement (continuous HV weld) fulfills the requirements of DIN 18800 i.e. the closed weld avoids corrosion and is thus suitable for outdoor use.

ATTENTION: Refer to the RUD user welding instructions!

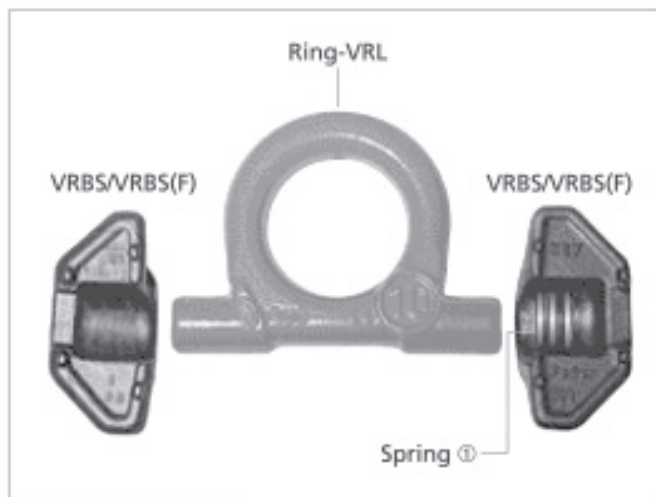

Subject to technical alterations

PIPE HANDLING

The Caldwell Group

Model PC — “Tea Cup” Pipe Carrier



FEATURES:

- An efficient way to handle concrete water and sewer pipes.
- The Caldwell “Tea Cup” Pipe Carrier will save you time and money.
- Three sizes available, to handle from 3/4” to 1-1/2” cable, and lift up to 15 tons.
- Designed and manufactured to ASME B30.20 and B30.9.

SPECIFICATIONS — Model PC

CERTEX Cat. Ref. No.	Caldwell Model No.	Rated Capacity Tons	Sling Dia. (in)	Dimensions in Inches							WT. (lbs)
				A	B	C	D	E	F	G	
CX10-0432 CX10-0433	PC-3/4	4.9	3/4” 7/8”	5-9/16	2	2-1/8	1-1/8	4-11/16	1-7/8	1-1/8	9
CX10-0434 CX10-0435 CX10-0436	PC-1	8.5	1” 1-1/8” 1-1/4”	6	2-1/2	2-5/8	1-3/8	5-5/8	2	1-3/8	12
CX10-0437	PC-1-1/2	15.0	1-1/2	8	3	3-1/4	1-5/8	7-5/8	3	1-5/8	22

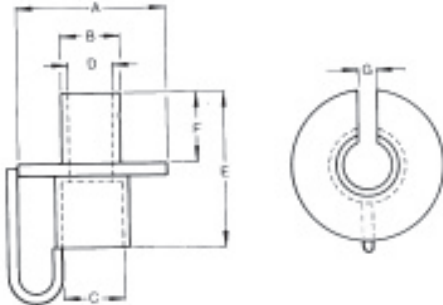

Tea Cup Lifting Sling Option — LS

CERTEX Cat. Ref. No.	Caldwell Model No.	Sling Dia. (in)	Standard Length (ft)	After Swage Dim. (in)		WT. (lbs)
				A	B	
CX10-0438	LS-3/4	3/4	5	3.25	1.55	9
CX10-0439	LS-7/8	7/8	5	3.86	1.80	14
CX10-0440	LS-1	1	5	4.36	2.05	19
CX10-0441	LS-1-1/8	1-1/8	5	4.81	2.30	26
CX10-0442	LS-1-1/4	1-1/4	5	5.42	2.56	33
CX10-0443	LS-1-1/2	1-1/2	5	6.52	3.00	52

SPECIFICATIONS — Model LS

Operation

10

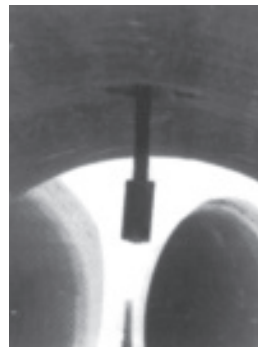

1. Drop pipe carrier lifting sling through hole in pipe.



2. Align and insert “tea cup” pipe carrier into lifting sling.



3. Lift pipe.

Beam Configurations

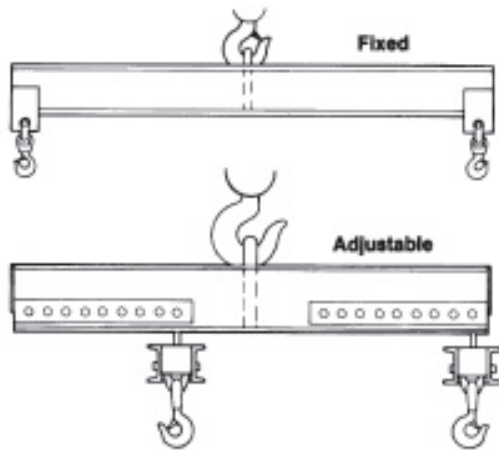

Four Point Lift Beams

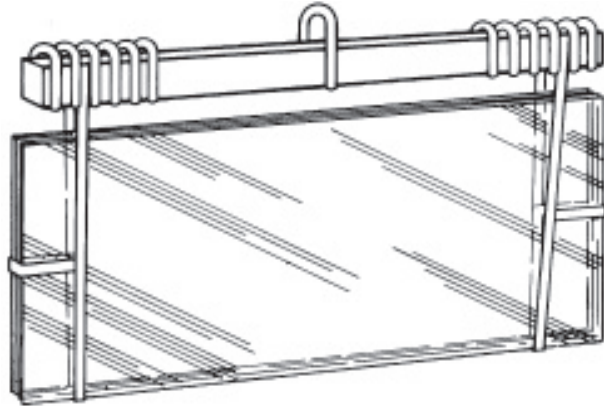
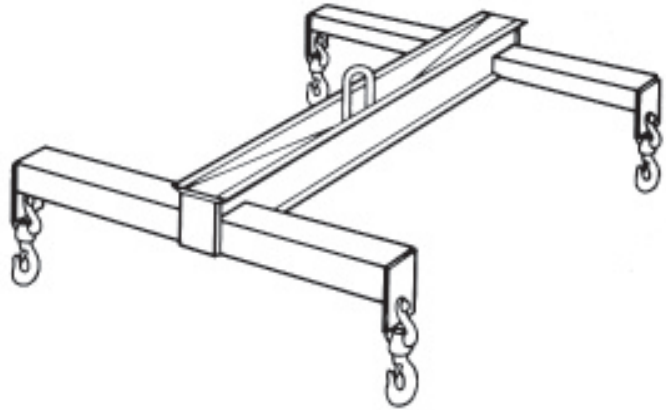

Glass Pack Beams. Custom lifting beam handles packs of glass panes with slings.

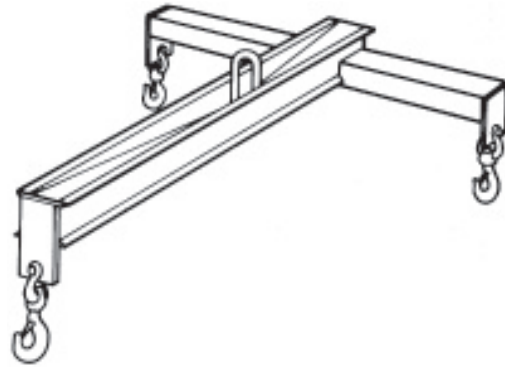

Three Point Lift Beam.

10



High Capacity Sling Beams

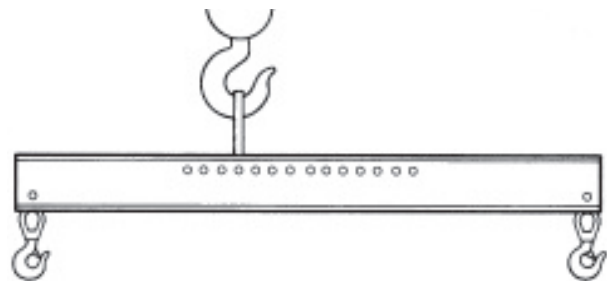

Adjustable Center Bail for Off-Center Loads

Beams and Spreaders can be made to meet your requirements exactly. A few examples of special configurations are shown here. Details will vary depending on capacity.

SPECIALTY BEAMS

The Caldwell Group

Model 16 — Adjustable Spreader/Lifting Beam

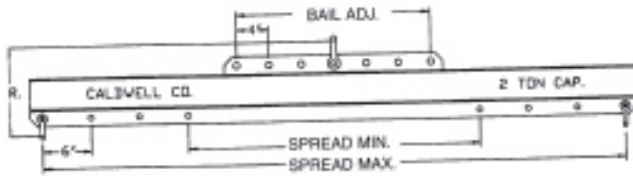

FEATURES:

- Use as 2, 3 or 4 point lifting or spreader beam.
- Converts to spreader beam with addition of top rigging.
- Has adjustable lifting points.
- Can handle both wide and unbalanced loads
- Low headroom capability.
- Shackles included.
- Designed and manufactured to ASME B30.20.

OPTIONS:

- Pair of swivel hooks — Code S
- Chain top rigging — Code C
- Cross beams (one or two) specify spread(s)
Consult Factory

SPECIFICATIONS

CERTEX Cat. Ref. No.	Caldwell Model No.	Rated Cap. (tons)	Spread (in)		Bail Adj. (in)	Hdrm. (in.)	Bolt Type Anchor Shackle (tons)		Wgt. (lbs.)
			Max	Min			Top	Bottom	
CX10-0445	16-1/2-6	1/2	72	36	24	8	1 1/2	1 1/2	70
CX10-0446	16-1-6	1	72	36	24	9 1/2	2	2	120
CX10-0447	16-2-6	2	72	36	24	11	3 1/4	2	140
CX10-0448	16-4-8	4	96	48	32	14 1/2	4 3/4	3 1/4	265
CX10-0449	16-5-10	5	120	60	40	17 1/4	6 1/2	4 3/4	445
CX10-0450	16-7-12	7	144	72	48	20 1/2	8 1/2	4 3/4	580

Operation

10

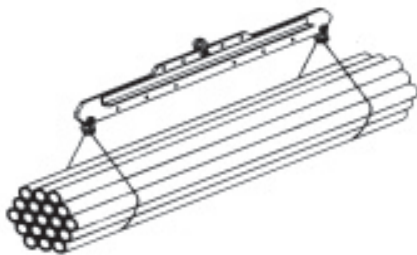

2 Point Lift

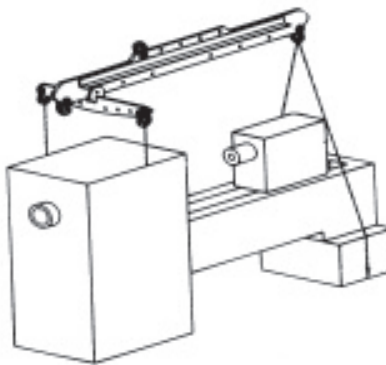

3 Point Lift

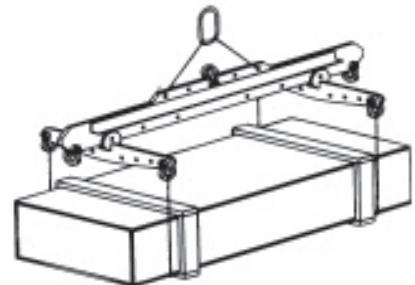

4 Point Lift

Ordering Instructions

Define Coil Sizes

Determine your maximum coil width (dimension "K"). Your C-Hook's nominal center of gravity, "E", should equal half of "K". This allows your widest coil to be centered under the lifting bail for a level lift.

If you are handling multiple coils or coiled rod or wire, please provide the maximum load width and request a quote on a "full length lower arm".

Determine your minimum coil width. The listed models show a range of coil widths which can be handled one at a time by the same lifter. (Larger ranges can be furnished.) "L" is the narrowest coil that can be lifted without the lifter's lower arm protruding past the edge of the coil. Coils narrower than "L" may be handled if centered under the bail.

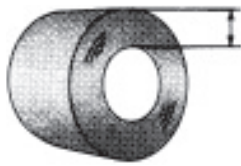
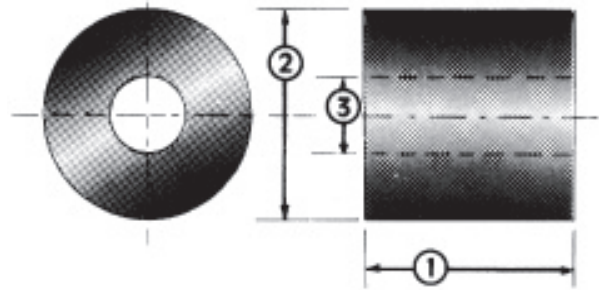

Radial Thickness

Determine maximum radial thickness to be handled. Most users select a vertical clearance, "V", that is 3" to 5" greater than the maximum radial thickness.

$$\text{Radial Thickness} = \frac{\text{Max. OD of coil} - \text{Min. ID of coil}}{2}$$

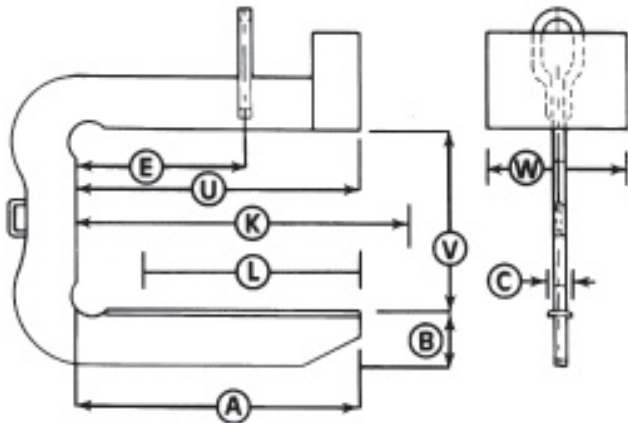

Coil Lifter Dimensions

- A. Lift Arm Length "
- B. Max. Arm Depth "
- C. Max. Arm Width "
- U. Upper Arm Length "
- V. Vertical Clearance "

Other Features . . .

Coil Load Details

1. Max. Width _____ Min. Width _____
 2. Max. Outside Diameter _____
 3. Min. Inside Diameter _____
 4. Max. Weight _____
- Will more than one coil be handled at once? _____

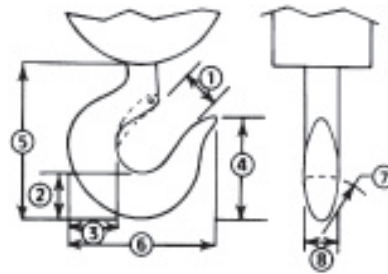

Hook Dimensions

1. _____ "
 2. _____ "
 3. _____ "
 4. _____ "
 5. _____ "
 6. _____ "
 7. _____ "
 8. _____ "
- Capacity _____ Tons.

COIL LIFTERS

The Caldwell Group

Model 82-RC — Close Stacking “C” Hook



PRODUCT FEATURES:

- Recessed Counterweight allows for close stacking of coils which maximizes floor space.
- Handles a wide range of coil widths.
- Designed for heavy duty application.
- High tensile alloy steel plate reduces physical size and weight.
- Counter balanced to hang level.
- Inside radius on hooks avoid coil edge contact.
- Curved coil saddle is standard.
- Guide handle for ease of coil positioning.
- Available with optional padding for additional coil protection.
- Designed and manufactured to ASME B30.20.

CAUTION: Center of gravity must be centered under crane hook to prevent tilting of the lifter and load.

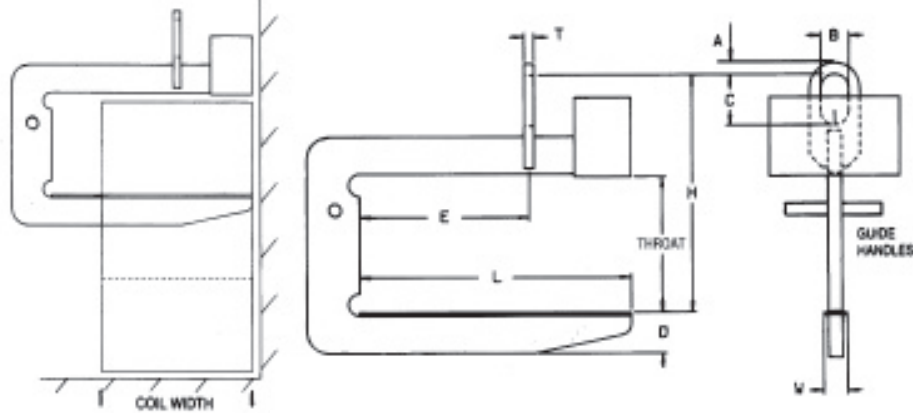

Note: “E” dimension is always one-half of maximum coil width.

SPECIFICATIONS

Dimensions in inches														
CERTEX Cat. Ref. No.	Caldwell Model No.	Cap. in tons	Coil Width		Throat	Lifting Arm			HDRM H	Bail Dimensions			Wgt. (lbs.)	
			Max	Min.		Length L	Depth D	Width W		Opening				
										A	B	C		THK. T
CX10-0454	82RC-5-36		36	24	24	30	5-5/16	4	37-1/4	1-1/2	4	7	1-1/4	550
CX10-0455	82RC-5-48	5	48	30	24	39	6-1/8	4	38-1/16	1-1/2	4	7	1-1/4	707
CX10-0456	82RC-5-60		60	36	24	48	6-15/16	4	38-15/16	1-1/2	4	7	1-1/4	853
CX10-0457	82RC-7 1/2-36		36	24	24	30	5-5/8	4	37-1/2	1-1/2	4	7	1-1/2	750
CX10-0458	82RC-7 1/2-48	7-1/2	48	30	24	39	6-3/8	4	38-1/4	1-1/2	4	7	1-1/2	996
CX10-0459	82RC-7 1/2-60		60	36	24	48	6-15/16	4	39	1-1/2	4	7	1-1/2	1161
CX10-0460	82RC-10-48		48	30	24	39	7-3/16	4	41-1/4	2	5	9	1-3/4	1200
CX10-0461	82RC-10-60	10	60	36	24	48	7-5/8	4	41-1/2	2	5	9	1-3/4	1645
CX10-0462	82RC-10-72		72	42	24	57	7-1/4	4	41-1/4	2	5	9	1-3/4	2100
CX10-0463	82RC-15-48		48	30	30	39	7-1/4	4	47-7/8	2-1/4	5	9	1-3/4	2054
CX10-0464	82RC-15-60	15	60	36	30	48	8	4	48	2-1/4	5	9	1-3/4	2410
CX10-0465	82RC-15-72		72	42	30	57	8-3/4	4	48-3/4	2-1/4	5	9	1-3/4	2814
CX10-0466	82RC-20-60	20	60	36	30	48	9-1/8	4	52-1/8	2-1/4	6	12	2	2864
CX10-0467	82RC-20-72		72	42	30	57	9-3/4	4	52-1/2	2-1/4	6	12	2	2951
CX10-0468	82RC-25-60	25	60	36	34	48	9	4	57-3/4	2-1/2	6	14	2-1/4	3077
CX10-0469	82RC-25-72		72	42	34	57	9-3/4	4	58-3/4	2-1/2	6	14	2-1/4	3570
CX10-0470	82RC-30-60	30	60	36	34	48	9-7/8	4	58-3/4	2-3/4	6	14	2-1/2	3480
CX10-0471	82RC-30-72		72	42	34	57	10-5/8	4	59-3/8	2-3/4	6	14	2-1/2	4260
CX10-0472	82RC-40-72	40	72	42	38	57	11	5	68	3-1/4	7	18	3	6100

Counter weight extends beyond arm one-half of the counter weight width, in capacities 25 Ton and Greater.
Other sizes available, consult factory.