



**FLINT & WALLING**

Zoeller Family of Water Solutions™

# LAWN SPRINKLER PUMPS

## SPJ Self-Priming 3/4 - 3 HP Single or Three Phase

- High capacity, high volume
- Cast iron pump body and mounting ring for long life
- Flint & Walling's Service Plus NEMA J, capacitor start, double ball bearing motors for continuous operation
- 3/4, 1, 1-1/2, 2 and 3 HP sizes, with single or three phase options
- Easy access drain plug
- Designed for lawn sprinkling, irrigation and more
- Rapid self-priming characteristics under maximum suction conditions

## SPM Series High Head 3 HP And 5 HP, Single or Three Phase

- High capacity, high pressure
- Large cast iron pump body to ensure rapid priming
- JM frame industrial duty motor
- Self-adjusting mechanical seal is water lubricated for trouble-free, maintenance free operation
- Designed for lawn and turf sprinkling, irrigation and water transfer
- Cast iron impeller for long life
- Built-in check valve facilitates priming and prevents backflow





**FLINT & WALLING**

Zoeller Family of Water Solutions™

## SPJ SELF-PRIMING 3/4 - 3 HP SINGLE OR THREE PHASE

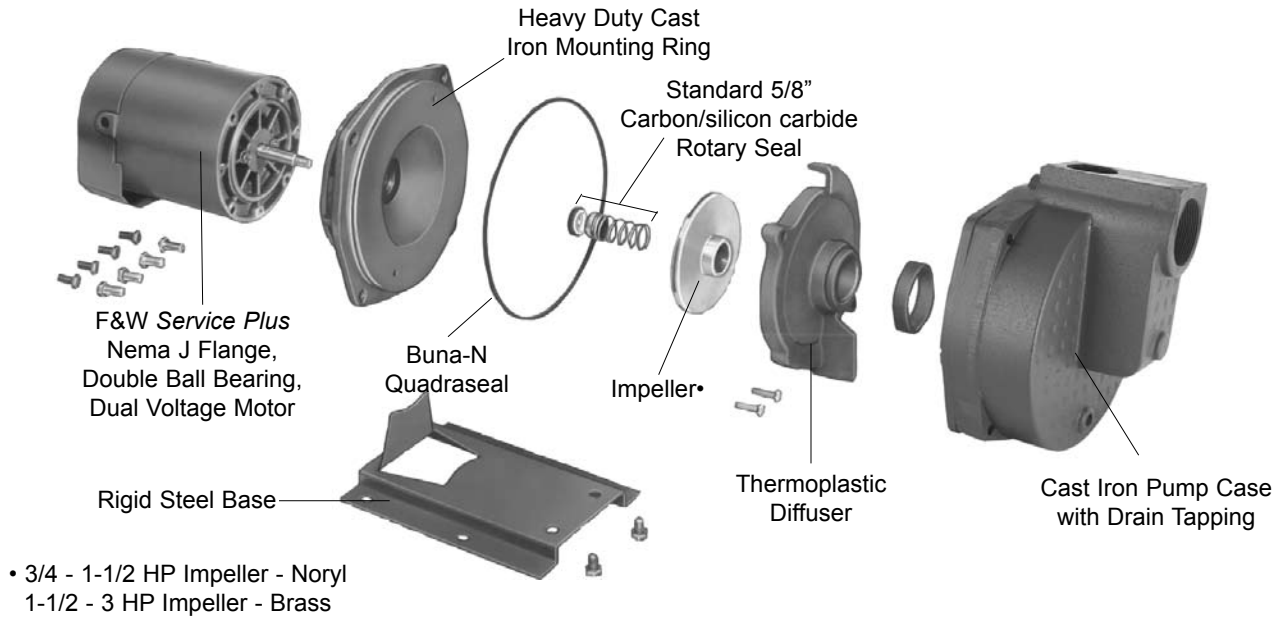

## SPM SERIES HIGH HEAD 3 HP and 5 HP, Single or 3 Phase

1. Housing - Cast iron ASTM 48 class 30
2. Impeller - Cast iron ASTM 48 Class 20, closed type, 6 vane
3. Diffuser - Cast iron ASTM 48 Class 20, 7 vane
4. Gasket - Red rubber
5. Seal - 1-1/4" Type 21 mechanical seal
6. Valve Gasket - Neoprene rubber, nylon fabric reinforced
7. Electric motor - JM Frame, industrial duty
8. Sleeve - Replaceable shaft sleeve, stainless steel type 304

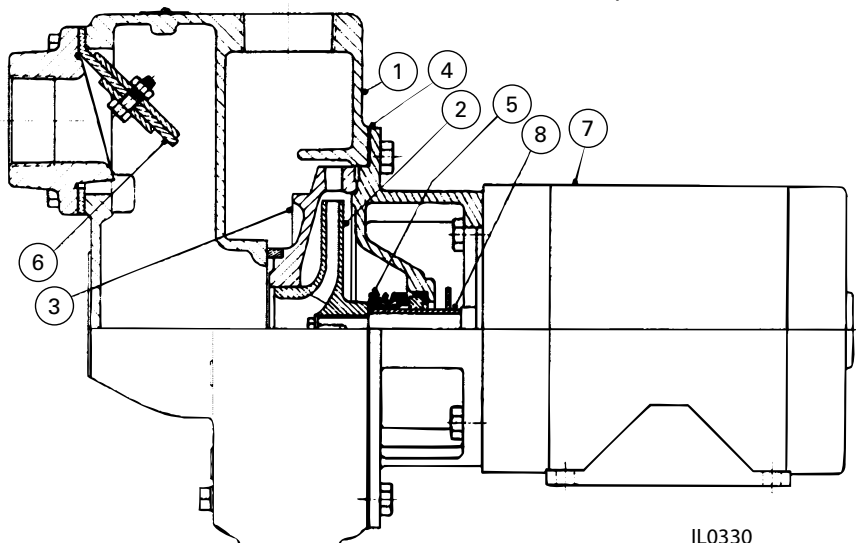

# SPJ SERIES PERFORMANCE



**FLINT & WALLING**

Zoeller Family of Water Solutions™

## SPECIFICATIONS

Model Number		HP	Suction Lift Ft.	Capacity - U.S. Gallons per Minute Discharge Pressure PSI								Shut-Off Pressure PSI	Suction Pipe Tap	Disch. Pipe Tap
1 Phase	3 Phase			10	15	20	25	30	35	40	45			
SPJ07P1	SPJ07P3	3/4	5	56	48	42	37	29	21			41	2"	1-1/2"
			15	47	42	37	29	22	12			37		
			25	43	37	31	22	10				33		
SPJ10P1	SPJ10P3	1	5	58	53	48	43	38	32	23	11	48	2"	1-1/2"
			15	53	48	45	37	31	24	12		43		
			25	48	44	38	33	25	14			39		
SPJ15P1 SPJ15B1	SPJ15B3	1-1/2	5	78	77	74	70	62	53	43	30	47	2"	1-1/2"
			15	70	68	66	62	53	43	30		41		
			25	47	46	45	44	42	34			36		
SPJ20B1	SPJ20B3	2	5	86	84	81	77	71	62	52	40	50	2"	1-1/2"
			15	76	74	72	69	64	55	43	25	45		
			25	52	51	50	47	45	42	30		40		
SPJ30B1	SPJ30B3	3	5	88	86	85	84	80	73	64	53	54	2"	1-1/2"
			15	77	76	75	74	72	65	55	43	50		
			25	54	53	52	51	50	49	45	10	45		

Motor voltage:

Single Phase 3/4 - 2 HP - 115/230V; 3 HP - 230V, 60Hz

Three Phase 3/4 - 2 HP - 208 - 230/460V, 50/60Hz; 3 HP - 208 - 230/460V; 60Hz

Maximum Case Pressure: 100 PSI

## PERFORMANCE CURVE

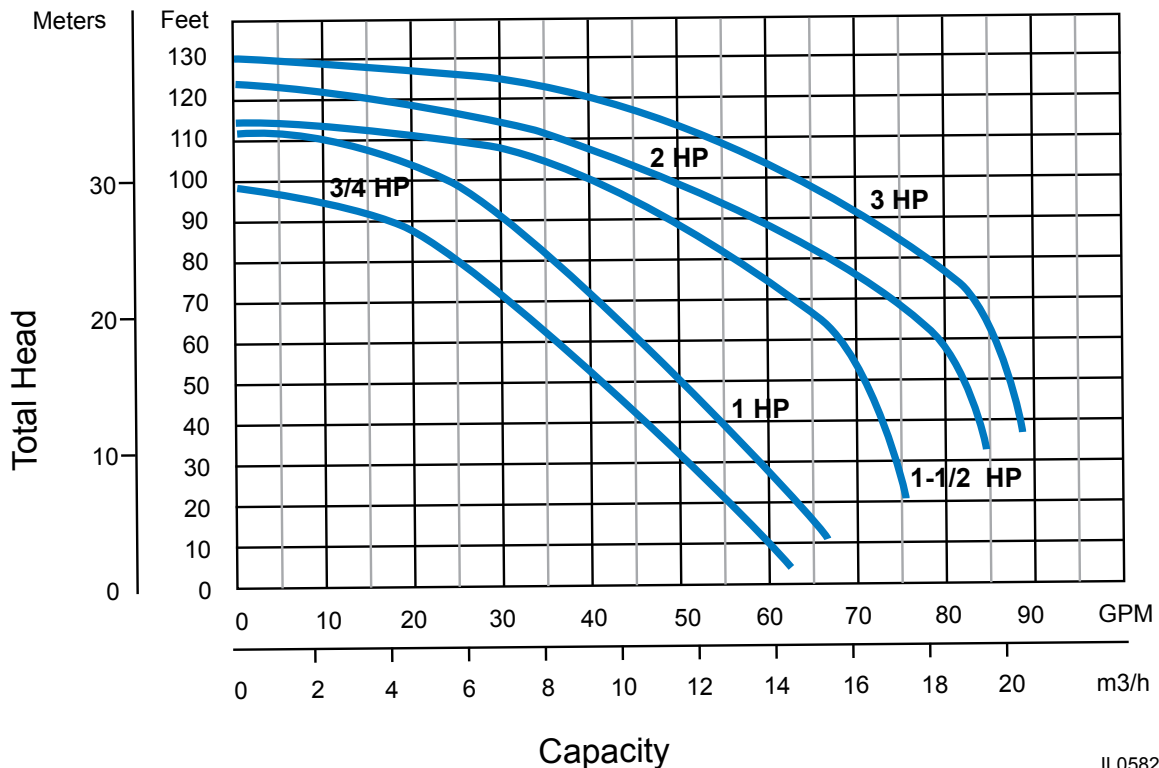

IL0582

# SPM SERIES PERFORMANCE



**FLINT & WALLING**

Zoeller Family of Water Solutions™

## PERFORMANCE SPECIFICATIONS

MODEL NUMBER		HP	SUCTION LIFT FT.	CAPACITY-U.S. GALLONS PER MINUTE DISCHARGE PRESSURE -PSI						SHUT-OFF PRESSURE PSI	SUCTION PORT NPT.	DISCHARGE PORT NPT.
1 PH.	3 PH.			10	20	30	40	50	60			
SPM30A1	SPM30A3	3	5	120	118	91	72	47		57.3	2"	2"
			10	103	100	88	68	40		55.2		
			15	91	90	83	66	31		53.0		
			20	76	75	74	59	19		50.8		
			25	54	54	54	49			48.7		
SPM50A1	SPM50A3	5	5		158	141	123	104	81	72.5	2 1/2"	2"
			10		138	127	115	99	67	70.3		
			15		124	117	107	92	64	68.2		
			20		104	102	96	82	48	66.0		

Motor Voltage: Single Phase: 3 HP, 115/230V 60Hz      Three Phase; 3-5 HP, 208-230/460, 60Hz  
 5 HP 230V, 60Hz  
 Maximum Case Pressure: 125 PSI

**MODEL SPM30A1, 3 HP, 1 PH**  
**MODEL SPM30A3, 3 HP, 3 PH**

**MODEL SPM50A1, 5 HP, 1 PH**  
**MODEL SPM50A3, 5 HP, 3 PH**

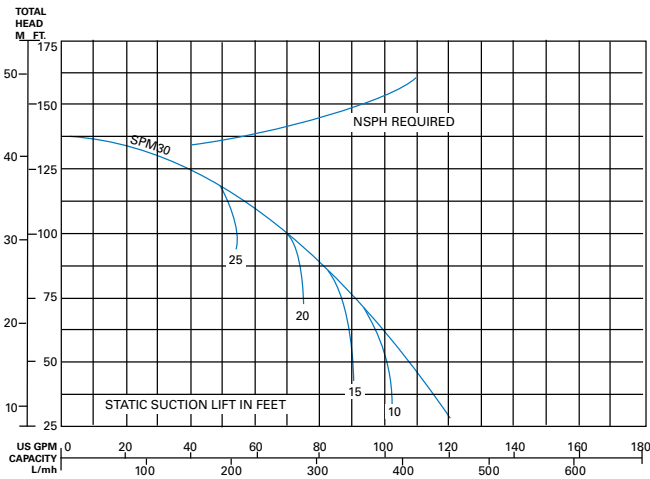

IL0353

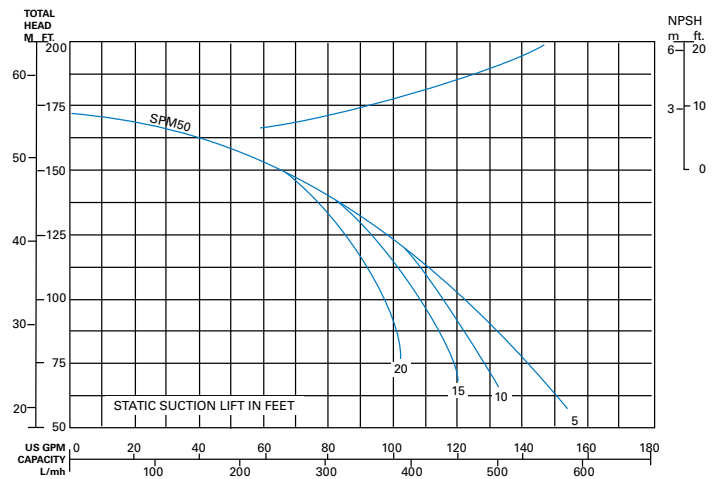

IL0354