

Synergy3™

Geothermal Heat Pumps with Water Heating for Radiant Floor Applications

- 4 thru 6 Ton

Design Features

Factory Options

Accessories

Dimensional Data

Physical Data

Performance Data

Engineering Guide Specifications





With the WaterFurnace Synergy3 Series, you'll provide superior comfort, incredible performance and energy savings. Integrating the comfort of a radiant floor heating system with the advantages of geothermal technology, the Synergy3 provides forced air heating and cooling to ducted zones while simultaneously providing hot water to radiant floor zones. The Synergy3 is the geothermal equivalent of a boiler, furnace and air conditioner— a three-in-one unit.

Synergy3 Series units are available in three sizes (4, 5 and 6 tons) and in vertical cabinet configurations. Cabinets are constructed with heavy-gauge metal and are coated with durable poly paint for long lasting beauty and protection. Units feature Copeland Scroll compressors for the ultimate in performance and reliability. Coated air coils add durability and longer life. Variable speed ECM blower motors are used for exceptional comfort and quiet operation. A sophisticated microprocessor control sequences all components during operation for optimum performance, and provides easy-to-use troubleshooting features with fault lights and on-board diagnostics. To help achieve ultimate heating comfort, priority staging is field selectable for either forced air zones or radiant floor zones.

Synergy3 products are performance-certified to ARI ISO 13256-1 standards and are ETL listed.

As a leader in the industry, WaterFurnace is dedicated to innovation, quality and customer satisfaction. In fact, every unit built is exposed to a wide range of quality control procedures throughout the assembly process and is then subjected to a rigorous battery of computerized run tests to certify that it meets or exceeds performance standards for efficiency and safety, and will perform flawlessly at startup. As further affirmation of our quality standards, each unit carries our exclusive Quality Assurance emblem, signed by the final test technician.

WaterFurnace International's corporate headquarters and manufacturing facility is located in Fort Wayne, IN. A scenic three-acre pond located in front of the building serves as our geothermal heating and cooling source to comfort-condition our 110,000 square feet of manufacturing and office space. As a pioneer, and now a leader in the industry, the team of WaterFurnace engineers, customer support staff and skilled assembly technicians is dedicated to providing the finest comfort systems available.

By choosing or specifying WaterFurnace Synergy3 products, you can be assured that your customer is investing in the ultimate comfort system and peace of mind for many years to come.

Table of Contents

ARI Data	4
Model Nomenclature	4
Application Information	5-6
Design Features	7
Synergy3 Features	8
Dimensional Data	9
Physical Data	9
Electrical Data	10
Auxiliary Heat Ratings	10
Auxiliary Heat Electrical Data	10
Operation Logic Data	10
Blower Performance Data	11
Entering Air Correction Factors	11
Wiring Schematic	12-13
Microprocessor Control Features	14
Reference Calculations	15
Legends and Notes	15
Capacity Data	16-21
Engineering Guide Specifications	22-23

ARI Data

Ground Loop Performance Ratings

UNIT SIZE	CFM	GPM	COOLING 77°F EWT		HEATING 32°F EWT	
			BTU/HR	EER	BTU/HR	COP
RTV046	1500	12.0	46,000	16.6	33,000	3.7
RTV056	1800	14.0	56,400	15.6	43,800	3.5
RTV066	2200	16.0	64,400	14.6	51,000	3.4



Notes: Rated in accordance with ARI/ISO Standards 13256-1:1998
 Cooling capacities based on 80°F DB, 66.2°F WB entering air temperature.
 Heating capacities based on 68°F DB entering air temperature.

Model Nomenclature

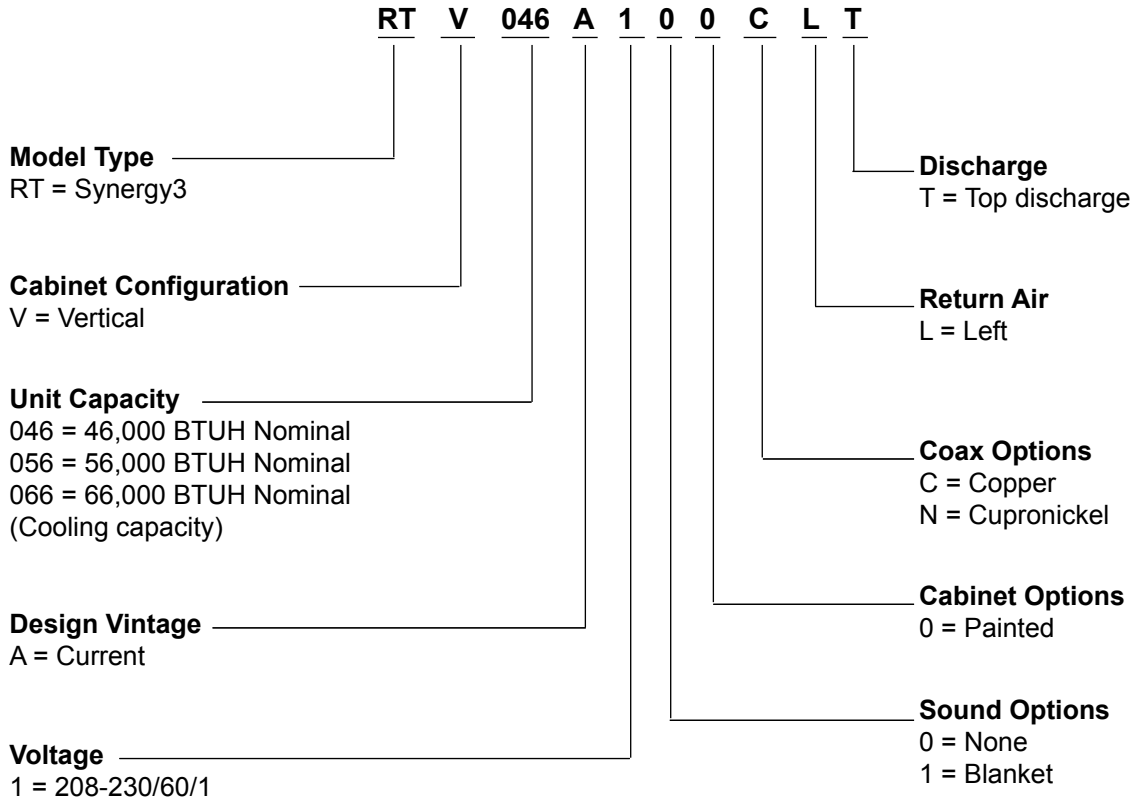

Application Information

Synergy3 units provide ducted heating and cooling, and hot water to radiant floor applications.

Most Synergy3 applications use multiple thermostats for heating. One or more thermostats may be dedicated to the forced air zone(s) while separate thermostats are used in the radiant floor zones. The microprocessor control in the unit allows for priority selection for either radiant or forced air zones, depending on the size, location and use of each zone.

Although the unit does not heat air and water simultaneously, the comfort “system” should be designed and controlled so that both functions occur simultaneously. This is achieved using a holding tank (buffer tank) for hot water. The buffer tank acts as a storage device for water heated using the Synergy3 unit. Warm water can be drawn from the buffer tank during forced air heating operation. At some point, the unit will need to switch from forced air heating mode to water heating mode when the temperature of the buffer tank drops below the setpoint. This switchover will occur either before or after the ducted zones are satisfied in heating, depending on the prioritization.

Typical water temperatures in radiant floor heating systems are around 100-105° F (38-40° C). Heat pumps using R-22 refrigerant are not designed to produce water above 130° F (54° C). The system efficiency decreases as the temperature difference (TD) between the heat source (generally the earth loop) and the supply water (the distribution system) increases. The heating capacity of the heat pump also decreases as the temperature difference increases.

When designing radiant floor distribution systems, the temperature limits of the geothermal system must be a

Figure 2: Air Flow for Ducted Zones, and Water Flow for Radiant Zones

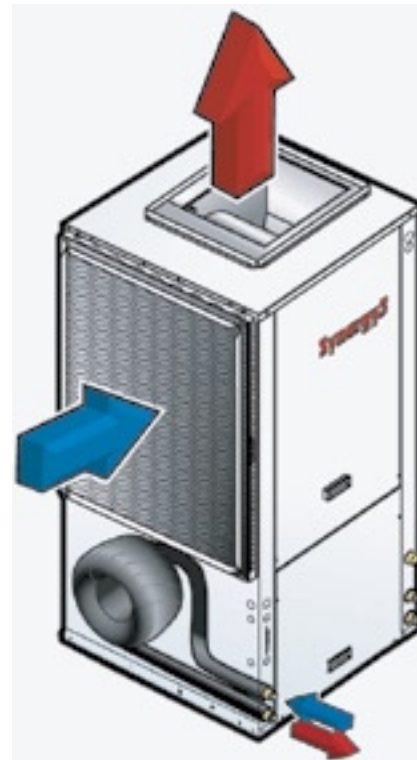

major consideration. In new construction, the distribution system can easily be designed with the temperature limits in mind. In retrofits, care must be taken to address the operating temperature limits of the existing distribution system.

Figure 1: Radiant Floor Heating



Application Information (continued)

Radiant Floor Heating

Radiant floor heating has been the system of choice in many parts of Europe for some time. Manufacturers have developed tubing designed for installation in concrete floors and built-up wood floors. Floor heating systems have several benefits in residential, commercial and industrial heating applications. In a building with a radiant floor heating system, the entire floor acts as a heat source for the room.

In residential applications, occupants in a space feel comfortable with lower air temperatures if their feet are warm. Typically the space will feel comfortable with air temperatures as low as 65° F (18° C). Since the heat loss of a building is directly related to the temperature difference between the inside and outside, a lower temperature difference means the heat loss is lower. Air temperatures in a room with a forced air heating system tend to be warmer near the ceiling than the floor. The hot air rises and creates a greater pressure imbalance between the inside and outside. The building's infiltration increases, resulting in a higher heat loss. Air temperatures in a room with floor heating tend to be warmer at the floor than the ceiling, helping cut down on infiltration in the building. The energy savings in a building with floor heating can range from 20-40% over traditional forced air systems.

Temperatures in a forced air system tend to be more uneven than in a radiant floor heating system. The air temperatures in a forced air system tend to be much higher than with radiant floor heating, making the temperature difference between inside and outside higher, which results in a higher BTU requirement.

Hydronic/geothermal systems can be used very effectively in new installations, as well as in many retrofit applications. Efficient systems can be built for residential, commercial and industrial applications.

To make a system as efficient as possible, it is important to follow good design criteria. Some of the factors to consider are listed below:

- An accurate heat loss and heat gain calculation must be done to size the system to operate efficiently.
- The system must meet the application requirements. In other words, the design of the system must take into consideration the type of distribution system and the needs of the customer.
- The components of the system must be designed to work together. The loop must be designed to work with the heat pumps, the pumping system must work efficiently with the earth loop and the heat distribution, and the distribution system must be chosen to work efficiently with the water temperatures available from the equipment.
- The system must be controlled to operate as efficiently as possible. It is important to operate the system to take variations in the building loads into account. For example, the heat loss of the building is reduced when the outdoor temperature climbs, and the temperature of the water circulated through the distribution system can be lowered, allowing the heat pumps to operate more efficiently.
- Modulating the various components of a system to meet the varying requirements of a building can significantly improve the efficiency of a system. Variable-speed pumps, for example, can greatly increase the overall efficiency of a system.
- The cost-effectiveness of the system must be considered. Regardless of the application, the design must take into account operating costs, installation costs and future repair/maintenance.

Figure 3 - Air Temperature Variations

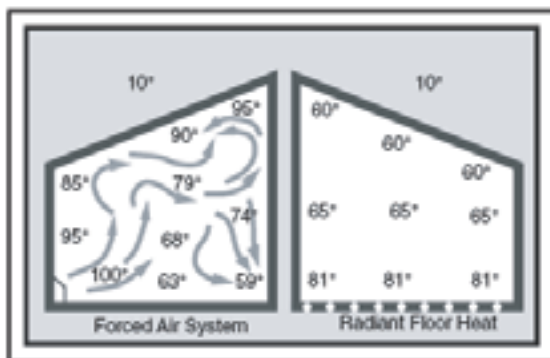

Note: Additional information on hydronic system design and application can be found in WFS272, and in the Synergy3 Installation Manual IM1554.

Design Features (continued)

Application Flexibility

- Safe, efficient operation in a wide range of liquid temperatures (25° F to 110° F) and flow rates (as low as 1.5 GPM/ton in open loop applications when EWT > 50°F).
- Variable-speed 1 HP ECM2 blowers permit various duct applications.
- Narrow cabinet for easy movement through doorways.
- Internally trapped condensate piping for neat, compact installation.
- Optional field-installed (internally mounted) auxiliary electric heater.
- Corner electrical box for field wiring from two sides.
- Fuse-protected loop pump power block for easy wiring.
- Loop pump control feature allows multiple units to share one flow center.
- Relays to control field-mounted air dampers.
- Field-selectable freeze protection setting for well or closed loop systems.
- Can be used for potable water heating when a code approved secondary heat exchanger is used. Maximum entering water temperature on the source (loop) side must not exceed 70° F.

Operating Efficiencies

- ARI/ISO Standard 13256-1 ratings for heating COPs and cooling EERs.
- Operating temperature range and high efficiency allows shorter earth loops.
- High-stability expansion valve delivers optimum refrigerant flow over a wide range of conditions and provides bi-directional operation without troublesome check valves.
- Efficient scroll compressors operate quietly.
- Oversized coaxial tube water-to-refrigerant heat exchanger operates at low liquid pressure drops. Convulsed copper (or optional cupronickel) water tube functions efficiently at low-flow rates and provides freeze-damage resistance.
- Oversized rifled copper tube/lanced aluminum fin air-to-refrigerant heat exchanger provides high efficiencies at low-face velocity.
- Large, low-RPM blowers with variable-speed motors provide quiet and efficient air movement with high static capability.

Service Advantages

- Removable panels provide quick access to all internal components with ductwork in place.
- Easily accessible thermal expansion valve.
- Brass, swivel-type water connections for quick connection, union and elimination of wrenches and sealants during installation.
- Insulated removeable divider panel and separate air handling/compressor access panels permit service testing without air bypass.
- Designed for front access in tight applications.

- LED fault and status lights with memory for easy diagnostics.
- Detachable low voltage connection strip for wiring convenience.
- Control box and fan motors have molded wiring connections for fast removal.
- Internal drop-out blower with permanently lubricated ball-bearing motor.
- High- and low-pressure service ports in refrigerant circuit.
- Fan and transformer powered from auxiliary heat supply (when installed) to provide emergency heat with open compressor circuit breaker.
- Factory-installed filter rack/duct collar.

Factory Quality

- All units are computer run-tested in all modes to ensure efficiency and reliability.
- Heavy-gauge steel cabinets are painted with durable epoxy for long lasting beauty and service.
- All refrigerant brazing is performed in a nitrogen atmosphere.
- All units are deep evacuated to less than 150 microns prior to refrigerant charging.
- All refrigerant joints are halogen leak tested to ensure system integrity.
- Refrigerant suction lines, the source coaxial heat exchanger, and water pipes are fully insulated to reduce condensation problems in low temperature operation.
- Noise reduction features include isolation mounted compressors and soft-starting blower motors; insulated compressor compartment; interior cabinet insulation using 1/2-inch coated glass fiber.
- Safety features include high- and low-pressure refrigerant controls to protect the compressor; condensate overflow protection; freeze protection sensor to safeguard the coaxial heat exchanger; fan start detection fault, lockout enables emergency heat and prevents compressor operation until thermostat or circuit breaker is reset.

Microprocessor Benefits

- Microprocessor based controls provide precise unit controls and simplified diagnostics.
- Component sequencing delays for quiet start up, shut down, and timed staging of auxiliary electric heat.
- Fan speed control provides higher supply air temperature in heating, better dehumidification in cooling, and quiet operation at reduced airflows in all modes.

Options & Accessories

- Optional cupronickel source coaxial heat exchanger.
- Multistage electronic auto-changeover thermostat.
- Closed loop flow center.
- Auxiliary electric heater.
- Hose kits.
- Sound blanket for compressor.

Synergy3 Features

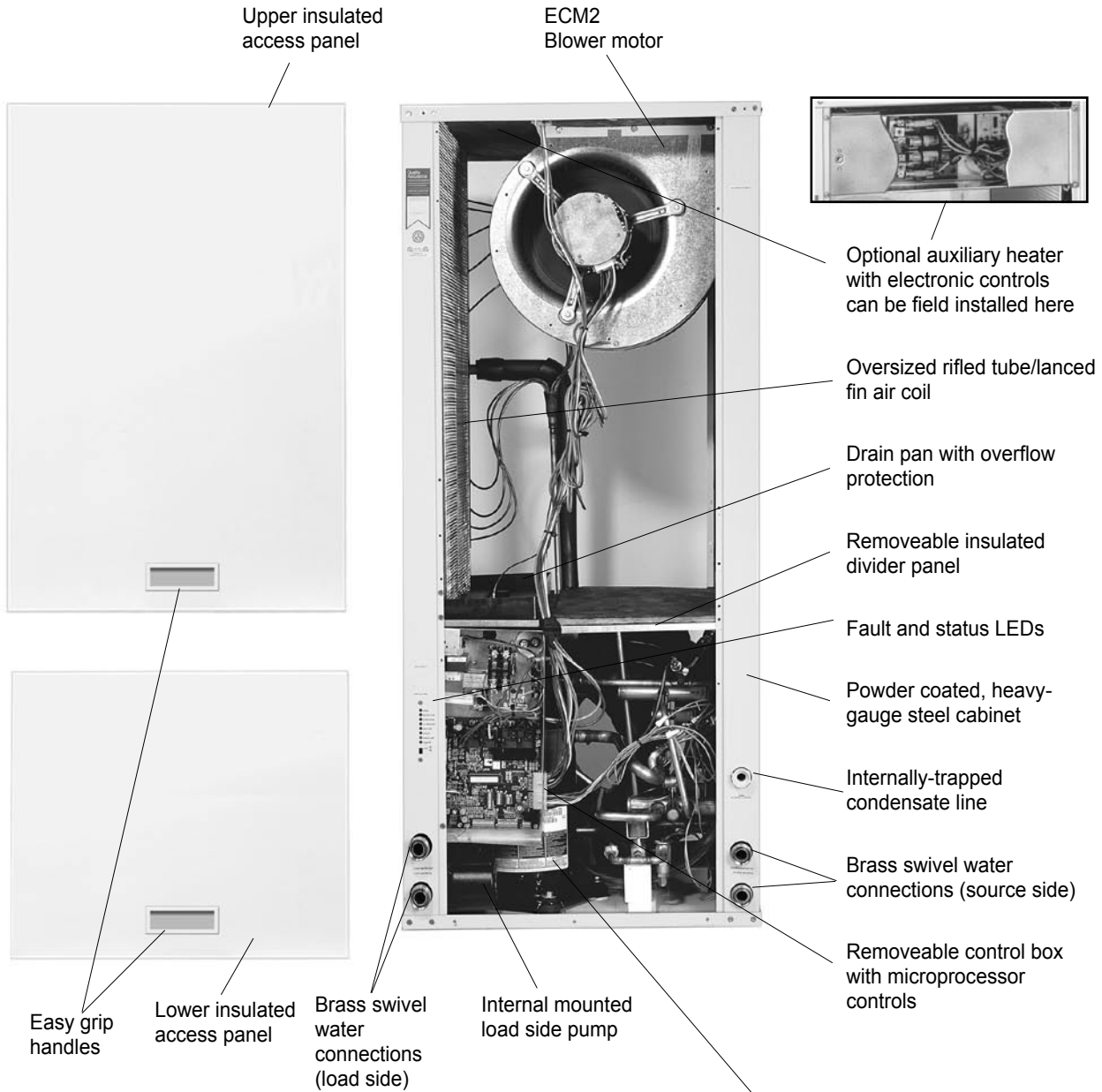

All Synergy3 units use advanced Copeland Scroll® compressor technology. Compared to conventional reciprocating piston technology, these revolutionary compressors deliver unprecedented performance. Their simple design makes a major contribution to the outstanding efficiency, comfort, reliability and quiet operation of the Synergy3 Series.



Dimensional Data

Figure 1: RTV Dimensional Data

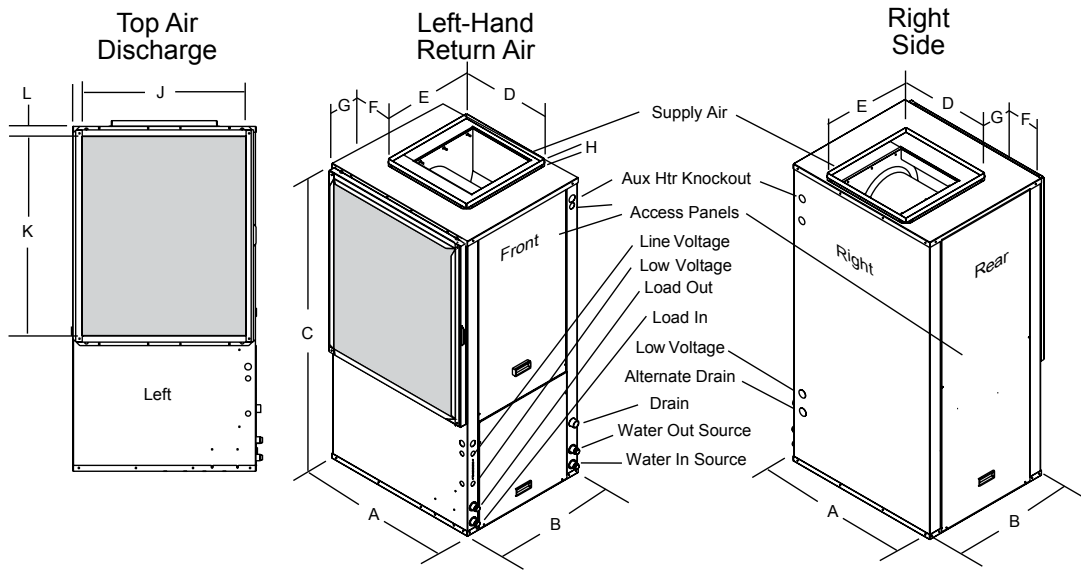

Dimensional Data

MODEL	AUX HEATER KNOCKOUT	A	B	C	D	E	F	G	H	I	J	K	L
RTV 046-066	1-3/8 "	31.2	25.5	58.8	18.0	18.0	6.6	6.4	1.0	1.6	28	33.9	1.7
	[3.5]	[79.3]	[64.8]	[149.4]	[45.7]	[45.7]	[16.8]	[16.3]	[2.5]	[4.1]	[71.1]	[86.1]	[4.3]

Notes: Inches [cm]

Physical Data

MODEL	RTV046	RTV056	RTV066
Fan Wheel	11x10 [27.9 x 25.4]		
Fan Motor	ECM2 1 HP		
Compressor	Scroll		
Air Coil:			
Dimensions	28 x 25 [72.4 x 63.5]	32 x 25 [81.3 x 63.5]	36 x 25 [91.4 x 63.5]
Area	4.9 [0.46]	5.6 [0.52]	6.3 [0.58]
Rows	3	3	3
Refrigerant:			
R22 Charge	84 [2.381]	88 [2.495]	102 [2.892]
Filters:			
Disposable	30 x 36 x 1 [76.2 x 91.4 x 2.5]		
Electrostatic	EAF3036		
Weight (lbs.)	380 [172.5]	425 [193]	454 [206]

Notes: Inches, [cm]

Air coil area dimensions in sq. ft., [sq. meters]

Refrigerant charge in ounces, [kg]

Unit weight in pounds, [kg]

Electrical Data

UNIT	RATED VOLTAGE	VOLTAGE MIN/MAX	COMPRESSOR			FAN MOTOR FLA	EXT PUMP FLA	INT PUMP FLA	TOTAL UNIT FLA	MAX FUSE	MIN CIRC AMP	MAX HACR BREAKER
			MCC	RLA	LRA							
RTV046	208-230/60/1	197/254	28.0	17.9	104.0	7.0	5.4	1.75	32.1	50	36.6	50
RTV056	208-230/60/1	197/254	31.0	19.9	137.0	7.0	5.4	1.75	34.0	50	39.0	50
RTV066	208-230/60/1	197/254	45.0	28.8	169.0	7.0	5.4	1.75	43.0	70	50.2	70

Notes: All fuses are class RK-5.
HACR circuit breaker in USA only.

Auxiliary Heat Ratings

MODEL	KW		STAGES	BTU/HR		MIN CFM	MODEL COMPATIBILITY		
	208V	240V		208V	240V		046	056	066
EAL10	7.2	9.6	2	24,600	32,700	1100	•	•	•
EAL15	10.8	14.4	3	36,900	49,100	1250	•	•	•
EAL20	14.4	19.2	4	49,200	65,500	1500	•	•	•

Note: High fan tap setting must be above the minimum CFM for the heater selected.

Auxiliary Heat Electrical Data

MODEL	SUPPLY CIRC	HEATER AMPS		MIN CIRC AMPS		FUSE (USA)		FUSE (CAN)		CRK BRK (CAN)	
		208V	240V	208V	240V	208V	240V	208V	240V	208V	240V
EAL10	Single	34.7	40.0	53.3	60.0	60	60	60	60	60	60
EAL15	Single	52.0	60.0	75.0	85.0	80	90	80	90	70	100
	L1/L2	34.7	40.0	53.3	60.0	60	60	60	60	60	60
	L3/L4	17.3	20.0	21.7	25.0	25	25	25	25	20	30
EAL20	Single	69.3	80.0	96.7	110.0	100	110	100	110	100	100
	L1/L2	34.7	40.0	53.3	60.0	60	60	60	60	60	60
	L3/L4	34.7	40.0	43.3	50.0	45	50	45	50	40	50

Notes: All heaters rated single phase 60 cycle and include unit fan load.
All fuses type "D" time delay (or HACR circuit breaker in USA).

Operation Logic Data

OPERATION LOGIC TABLE	HEATING			COOLING	HOT WATER MODE
	STG 1	STG2	EMERG	STG 1	
Compressor	On	On	Off	On	On
Rev Valve	Off	Off	Off	On	Off
Loop Pump	On	On	Off	On	On
HW Pump	Off	Off	Off	Off	On
Aux Heater	Off	Staged	Staged	Off	Off
Acc Relay	On	On	Off	On	Off
Diverting Valve	Off	Off	Off	Off	On
ECM Speed	On	On	On	On	Off
T-Stat Signal	Y1	Y1, W	W	Y1, O	HW
Damper	Off	Off	On	Off	Off
Secondary 1 - Out	On	On	Off	On	On

Blower Performance Data

MODEL	MAX ESP	1	2	3	4	5	6	7	8	9	10	11	12
RTV046	0.75	750 L	400	1000	1200 M	1400	1600 H	1700					
RTV056	0.75	750	900 L	1000	1200	1400 M	1600	1700	1850 H	2000	2200	2300	2400
RTV066	0.75	750	900	1000 L	1200	1400	1600 M	1700	1850	2000	2200 H	2300	2400

Notes: Factory settings are recommended L-M-H-DIP switch locations.

Factory L settings for constant fan only.

M-H settings must be located within boldface CFM range.

CFM is controlled within 5% up to the maximum ESP.

Max ESP includes allowance for wet coil and standard filter.

A 12-position DIP switch package on the Synergy3 control allows the airflow levels to be set for Low, Medium and High speed when using the ECM2 blower motor.

Only three of the DIP switches can be in the “On” position. The first “On” switch (the lowest position number) determines the “Low Speed Fan” setting. The second “On” switch determines the “Medium Speed Fan” setting, and the third “On” switch determines the “High Speed Fan” setting.

The example to the right shows SW1 on the Synergy3 control board configured for the following RT046 airflow settings:

- Low Speed Fan: 750 CFM
- Medium Speed Fan: 1200 CFM
- High Speed Fan: 1600 CFM

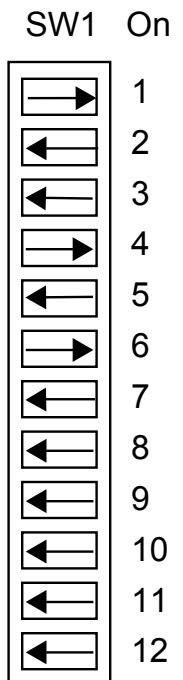

Entering Air Corrections Factors

COOLING					HEATING			
EAT	TC	SC	KW	HR	EAT	HC	KW	HE
75/63	0.92	0.96	0.98	0.94	60	1.03	0.95	1.06
80/67	1.00	1.00	1.00	1.00	70	1.00	1.00	1.00
85/71	1.08	1.04	1.02	1.06	80	0.97	1.05	0.94

Synergy3 Wiring Schematic 208-230/60/1

(Part 1 of 2)

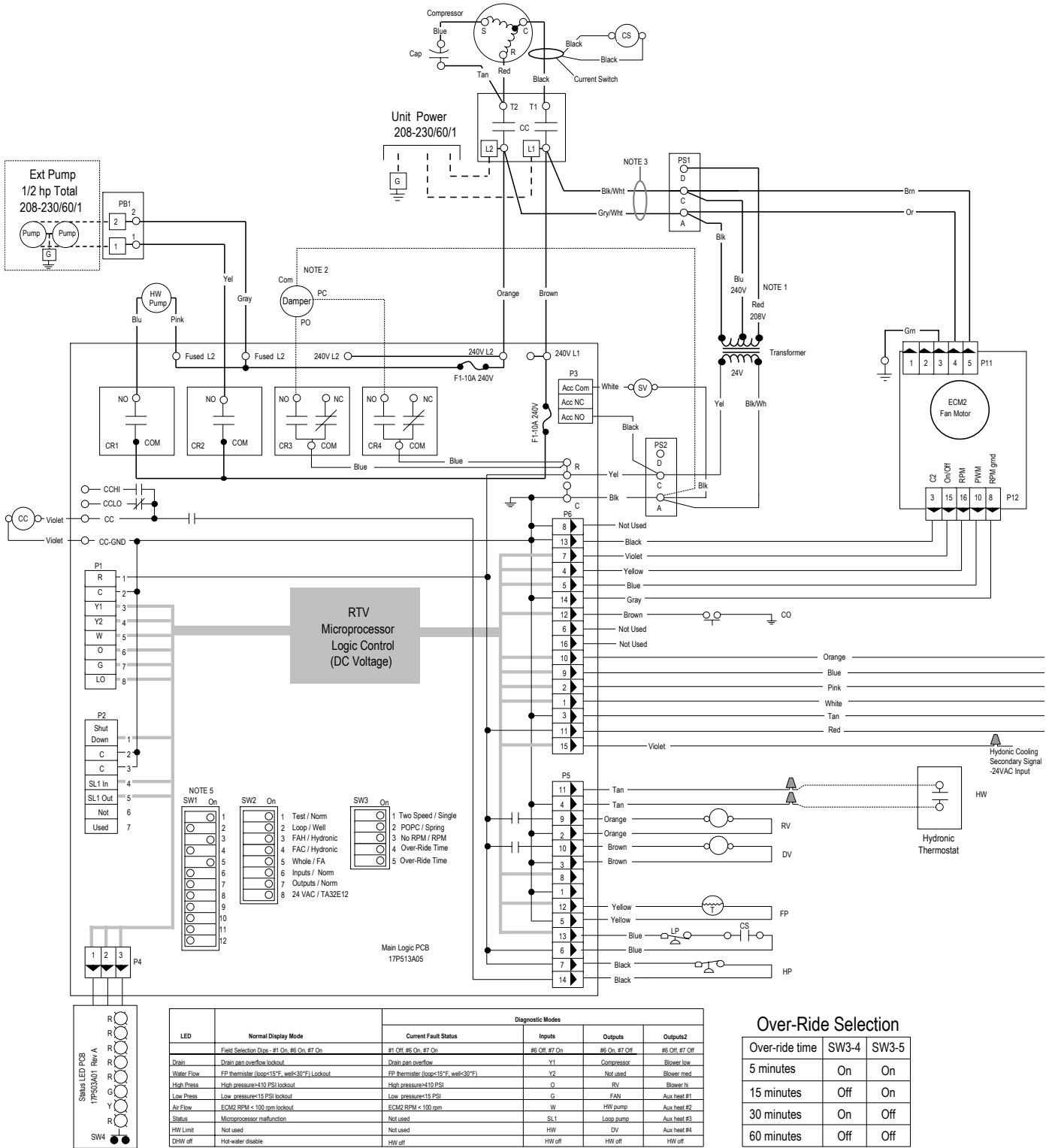

LED	Normal Display Mode	Diagnostic Modes		
		Current Fault Status	Inputs	Outputs
	Field Selection Dips: #1 On, #5 On, #7 On	#1 Off, #6 On, #7 On	#6 Off, #7 On	#5 Off, #7 Off
Drain	Drain pan overflow lockout	Drain pan overflow	Y1	Compressor
Water Flow	FP thermostat (loop<15°F, wet<30°F) Lockout	FP thermostat (loop<15°F, wet<30°F)	Y2	Not used
High Press	High pressure<410 PSI lockout	High pressure<410 PSI	O	RV
Low Press	Low pressure<15 PSI lockout	Low pressure<15 PSI	G	FAN
Air Flow	ECM2 RPM < 100 rpm lockout	ECM2 RPM < 100 rpm	W	HW pump
Status	Microprocessor malfunction	Not used	SL1	Loop pump
HW Limit	Not used	Not used	HW	DV
DHW off	Hot-water disable	HW off	HW off	HW off

Over-Ride Selection

Over-ride time	SW3-4	SW3-5
5 minutes	On	On
15 minutes	Off	On
30 minutes	On	Off
60 minutes	Off	Off

Synergy3 Wiring Schematic

(Part 2 of 2)

208-230/60/1

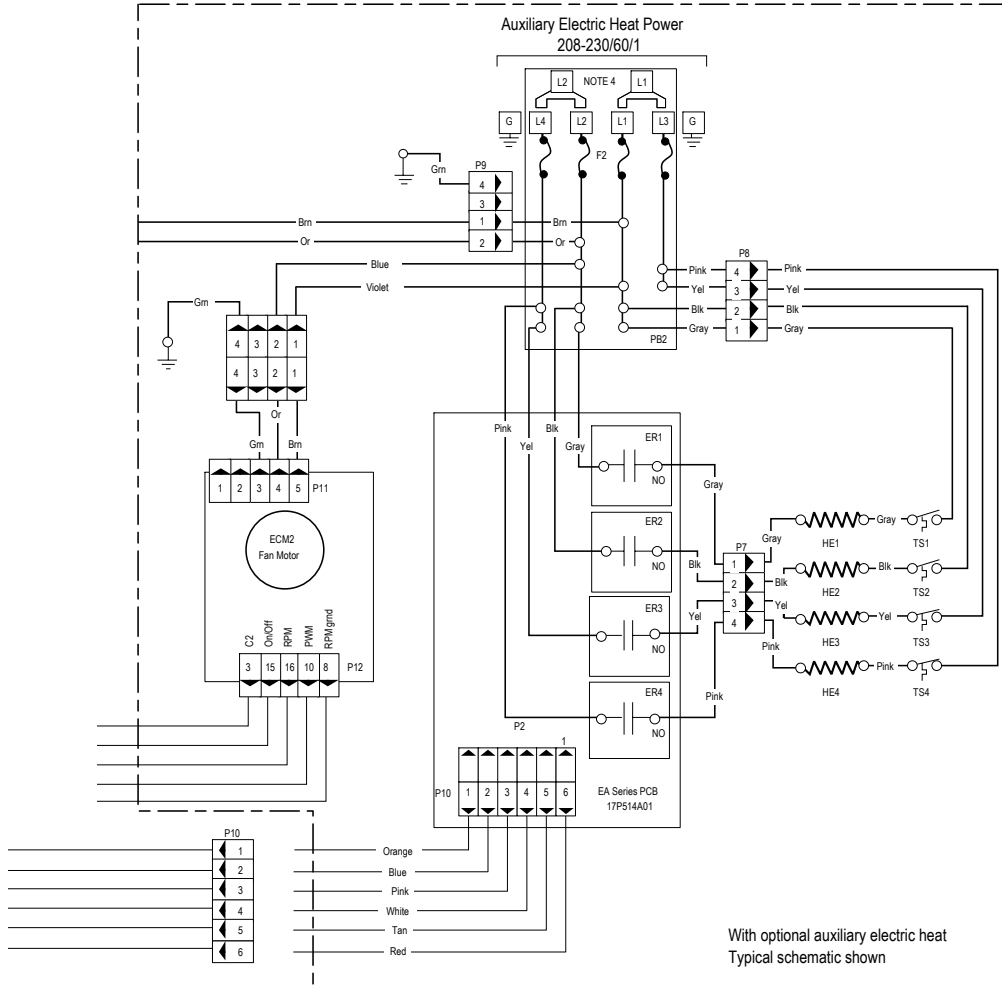

- Notes:**
1. Switch blue and red wires for 208V operation.
 2. Typical hook-up shown for power open - power closed damper shown.
 3. The blk/wh and gray/wh wires are removed when Aux Heat is installed.
 4. Bus lugs L1 and L2 can be removed and dual power wire sets connected directly to box lugs L1, L2 and L3 and L4.
 5. Air Flow Configuration Example: SW1 configured for dip 1 as low, dip 3 as medium, and dip 5 as high speed ECM2 fan.
 6. When using thermostat TA32E12, SW2-8 should be in the "ON" position.
When using 24VAC thermostats, SW2-8 should be in the "OFF" position.

Legend

	Factory Low voltage wiring		Thermistor
	Factory Line voltage wiring		Light emitting diode - Green
	Field low voltage wiring		Relay coil
	Field line voltage wiring		Capacitor w/ bleed resistor
	Optional block DC Voltage PCB traces		Switch - Condensate overflow
	Internal junction		Switch - High pressure
	Quick connect terminal		Switch - Low pressure
	Wire nut		Switch - Hot Water On/Off
	Field wire lug		Polarized connector
	Ground		
	Relay Contacts- N.O., N.C.		
	Fuse		
	Solenoid valve		

CS -	Current Switch	LP -	Low pressure switch
CC -	Compressor Contactor	PB1 -	Power block
CO -	Condensate overflow sensor	PS1,PS2 -	Power strips
CR1 -	HW pump relay	RV -	Reversing Valve coil
CR2 -	Loop pump relay	SW1 -	DIP package 12 position
CR3 -	Damper relay	SW2 -	DIP package 8 position
CR4 -	Damper relay	SW3 -	DIP package 5 position
F1 and F2 -	Fuses	SW4 -	Hot water enable switch
FP -	Freeze protection sensor	DV -	Diverting valve
HP -	High pressure switch		

Microprocessor Control Features

The Synergy3 control system is a microprocessor-based printed circuit board conveniently located in the unit control box for accessibility. The microprocessor control is specifically designed for the Synergy3 series heat pumps which integrate the ECM2 blower motor. All ECM2 airflow selections are conveniently configured on the control via DIP switches. The microprocessor provides control of the entire unit as well as outputs for status modes, faults, and diagnostics. LEDs are located on the front of the unit for quick inspection without removing any access panels. Either 24VDC or 24VAC thermostats can be used.

Startup

The unit will not operate until all the inputs and safety controls are checked for normal conditions. At first power-up, a four-minute delay is employed before the compressor is energized.

Component Sequencing Delays

Components are sequenced and delayed for optimum space conditioning performance.

Accessory Relay

The accessory relay will be used to control a refrigerant solenoid valve. The accessory relay will turn on when the control is operating in forced air heating or forced air cooling and will remain off when operating in hot water mode or there is no active thermostat input.

Short Cycle Protection

The control employs a minimum “off” time of four minutes and a minimum “on” time of one minute to provide for short cycle protection of the compressor.

Loop Pump Slaving Signals

A signal between multiple Synergy3 control boards at the inputs and outputs (SL1-In and Out) will provide for remote control of the loop pump on any unit.

Condensate Overflow Protection

The Synergy3 control board incorporates an impedance sensing liquid sensor at the top of the drain pan. Upon a continuous 30-second sensing of the condensate, compressor operation is suspended (see Fault Retry), the condensate overflow lockout LED begins flashing, and an output signal (LO) is made available for connection to a “fault” LED at the thermostat.

Shutdown Input

A simple grounded signal to the “shutdown” input on the control board puts the unit into shutdown mode. Compressor, hot water pump and fan operation are suspended.

Safety Controls

The Synergy3 control receives separate signals for a high pressure switch for safety, a low pressure switch to prevent loss of charge damage, and a low suction temperature thermistor for freeze protection. Upon a continuous 30-second measurement of the fault (immediate for high pressure), compressor operation is suspended (see Fault Retry), the appropriate lockout LED begins flashing, and an output signal (LO) is made available for connection to a “fault” LED at the thermostat.

Testing

The Synergy3 control allows service personnel to shorten most timing delays for faster diagnostics.

Fault Retry

All faults (except for low RPM fault with the ECM2 fan motor) are retried twice before finally locking the unit out. The “Fault Retry” feature is designed to prevent nuisance service calls.

Diagnostics

The Synergy3 control board allows all inputs and outputs to be displayed on the LEDs for fast and simple control board diagnosis.

Resistance Heat Control

The electric heat control module contains the appropriate high-voltage control relays. Control signals energize the relays in the proper sequence, and the LED display board indicates which stages are energized.

Hot Water Disable Switch

The switch on the LED status display will be used by the control to disable the “HW” input and to open the damper connected to CR3 and/or CR4.

ECM2 Airflow Selection DIP Switches (SW1)

A 12-position DIP switch package on the Synergy3 control allows the airflow levels to be set for low, medium and high speed when using the ECM2 blower motor (see Synergy3 Fan Performance Data Table, page 11).

Only three of the DIP switches can be in the “On” position. The first “On” switch (the lowest position number) determines the “Low Speed Fan” setting. The second “On” switch determines the “Medium Speed Fan” setting, and the third “On” switch determines the “High Speed Fan” setting.

Reference Calculations

Heating Calculations:	Cooling Calculations:
$LWT = EWT - \frac{HE}{GPM \times 500}$	$LWT = EWT + \frac{HR}{GPM \times 500}$
$LAT = EAT + \frac{HC}{CFM \times 1.08}$	$LAT (DB) = EAT (DB) - \frac{SC}{CFM \times 1.08}$
$TH = HC + HW$	$LC = TC - SC$
	$S/T = \frac{SC}{TC}$

Legends and Notes

ABBREVIATIONS AND DEFINITIONS

CFM	= airflow, cubic feet/minute	KW	= kilowatts
COP	= coefficient of performance = (btu output/btu input) = [HC/(kw x 3.413)]	LAT	= leaving air temperature °F
EAT	= entering air temperature °F	LC	= latent cooling capacity in MBTUH
EER	= energy efficient ratio = btu output / watt input	LGPM	= load flow in gallons per minute
ELT	= entering load fluid temperature to heat pump	LLT	= leaving load fluid temperature from heat pump
EST	= entering source fluid temperature to heat pump	LST	= leaving source fluid temperature from heat pump
EWT	= entering water temperature (source) to heat pump	LWPD	= load coax water pressure drop
FT HD	= pressure drop in feet of head	LWT	= leaving water temperature °F
GPM	= gallons per minute	PSI	= pressure drop in pounds per square inch
HC	= total heating capacity in MBTUH	S/T	= sensible to total cooling ratio
HE	= heat extracted in MBTUH	SC	= sensible cooling capacity in MBTUH
HR	= heat rejected in MBTUH	SWPD	= source coax water pressure drop
		TC	= total cooling capacity in MBTUH
		TH	= total heating capacity in MBTUH
		WPD	= water pressure drop in PSI, feet of water

Notes: Capacity data tables on pages 16-21 do not include water pumping watts and are based upon 15% (by volume) methanol antifreeze solution.

For non-standard EAT conditions, apply the appropriate correction factors found on page 11.

Interpolation between EWT, GPM and CFM data is permissible.

Extrapolation for heating data down to 25° F is permissible.

Catalog illustrations cover the general appearance of WFI products at time of publication. We reserve the right to make changes in design and construction at any time without notice.

RTV046

Heating and Cooling Capacity Data

EWT	GPM	WPD		CFM	HEATING ONLY				
		PSI	FT		HC	KW	HE	LAT	COP
30	6.0	2.7	6.2	1000	30.9	2.62	21.9	98.6	3.46
				1500	32.2	2.55	23.5	89.9	3.70
	9.0	5.5	12.7	1000	32.1	2.68	23.0	99.7	3.51
				1500	33.3	2.60	24.4	90.6	3.75
	12.0	8.8	20.3	1000	33.3	2.74	23.9	100.8	3.56
				1500	34.5	2.66	25.4	91.3	3.80
50	6.0	2.6	6.0	1000	40.9	3.11	30.3	107.9	3.85
				1500	42.7	2.98	32.6	96.4	4.20
	9.0	5.2	12.0	1000	42.3	3.19	31.4	109.2	3.89
				1500	44.2	3.04	33.9	97.3	4.26
	12.0	8.3	19.2	1000	43.6	3.24	32.6	110.4	3.94
				1500	45.7	3.09	35.1	98.2	4.33
70	6.0	2.2	6.0	1000	51.6	3.49	39.7	117.8	4.33
				1500	54.4	3.28	43.1	103.6	4.85
	9.0	4.7	10.9	1000	53.4	3.58	41.2	119.4	4.37
				1500	56.4	3.35	44.9	104.8	4.93
	12.0	7.6	17.6	1000	54.8	3.62	42.5	120.8	4.43
				1500	58.0	3.39	46.4	105.8	5.01
90	6.0	2.1	4.9	1000	62.3	3.90	48.9	127.7	4.67
				1500	66.2	3.61	53.9	110.9	5.38
	9.0	4.6	10.6	1000	64.5	4.00	50.8	129.7	4.72
				1500	68.8	3.68	56.2	112.5	5.47
	12.0	7.4	17.1	1000	66.0	4.03	52.2	131.1	4.79
				1500	70.5	3.70	57.8	113.5	5.58

EWT	GPM	WPD		CFM	COOLING ONLY				
		PSI	FT		TC	SC	KW	HR	EER
50	6.0	2.6	6.0	1000	47.4	29.6	2.17	54.8	21.8
				1200	48.9	32.4	2.27	56.7	21.6
	9.0	5.2	12.0	1000	47.7	29.7	2.09	54.8	22.8
				1200	49.2	32.5	2.18	56.6	22.5
	12.0	8.3	19.2	1000	47.9	29.7	2.03	54.9	23.6
				1200	49.5	32.6	2.12	56.7	23.3
70	6.0	2.2	6.0	1000	44.7	28.7	2.56	53.4	17.5
				1200	46.1	31.4	2.68	55.2	17.2
	9.0	4.7	10.9	1000	45.0	28.8	2.47	53.5	18.2
				1200	46.4	31.6	2.59	55.3	17.9
	12.0	7.6	17.6	1000	47.4	34.7	2.76	56.8	17.2
				1200	45.4	28.9	2.41	53.6	18.8
90	6.0	2.1	4.9	1000	44.7	31.7	2.53	55.4	18.5
				1200	46.8	31.7	2.53	55.4	18.5
	9.0	4.6	10.6	1000	47.8	34.8	2.69	57.0	17.8
				1200	47.8	34.8	2.69	57.0	17.8
	12.0	7.4	17.1	1000	41.0	27.3	3.07	51.5	13.3
				1200	42.3	30.0	3.23	53.3	13.1
110	6.0	2.0	4.7	1000	43.2	32.9	3.43	54.9	12.6
				1500	43.2	32.9	3.43	54.9	12.6
	9.0	4.6	10.6	1000	41.4	27.5	2.99	51.6	13.9
				1200	42.7	30.2	3.14	53.4	13.6
	12.0	7.4	17.1	1000	43.6	33.2	3.34	55.0	13.1
				1500	43.6	33.2	3.34	55.0	13.1
110	6.0	2.0	4.7	1000	41.9	27.6	2.93	51.8	14.3
				1200	43.2	30.3	3.07	53.7	14.0
	9.0	4.5	10.3	1000	44.1	33.3	3.27	55.2	13.5
				1500	44.1	33.3	3.27	55.2	13.5
	12.0	7.2	16.6	1000	36.8	25.8	3.77	49.7	9.8
				1200	38.0	28.3	3.97	51.5	9.6
110	6.0	2.0	4.7	1000	38.8	31.1	4.22	53.2	9.2
				1500	38.8	31.1	4.22	53.2	9.2
	9.0	4.5	10.3	1000	37.3	26.1	3.68	49.9	10.1
				1200	38.5	28.6	3.87	51.7	9.9
	12.0	7.2	16.6	1000	39.3	31.5	4.12	53.3	9.5
				1500	39.3	31.5	4.12	53.3	9.5
12.0	7.2	16.6	1000	37.8	26.1	3.62	50.1	10.4	
			1200	39.0	28.7	3.82	52.0	10.2	
12.0	7.2	16.6	1000	39.7	31.5	4.06	53.6	9.8	
			1500	39.7	31.5	4.06	53.6	9.8	

Notes: Multiple Flow Rates (for EWT) are shown in the tables above. The lowest flow rate shown is used for geothermal open loop/well water systems with a minimum 50° F. The second flow rate shown is the minimum geothermal closed loop flow rate. The third rate shown is optimum for geothermal closed loop and the suggested flow rate for boiler tower applications.

RTV046

Water Heating Data (Load Pump Watts Included)

ELT	EST	LGPM	SOURCE 6.0 GPM							SWPD		SOURCE 9.0 GPM							SWPD		SOURCE 12.0 GPM							SWPD	
			LLT	HC	KW	HE	COP	LST	PSI	FT HD	LLT	HC	KW	HE	COP	LST	PSI	FT HD	LLT	HC	KW	HE	COP	LST	PSI	FT HD			
80	30	6.0	90.3	30.8	2.82	21.2	3.2	26.4	2.7	6.2	90.8	32.3	2.84	22.6	3.3	26.1	5.8	13.3	91.3	33.8	2.87	24.0	3.5	25.9	8.8	20.3			
		9.0	87.0	31.5	2.72	22.2	3.4	26.2	2.7	6.2	87.4	33.1	2.78	23.6	3.5	25.9	5.8	13.3	87.7	34.7	2.84	25.0	3.6	25.7	8.8	20.3			
		12.0	85.4	32.2	2.62	23.2	3.6	26.0	2.7	6.2	85.7	33.9	2.71	24.7	3.7	25.8	5.8	13.3	85.9	35.7	2.80	26.1	3.7	25.5	8.8	20.3			
	40	6.0	91.9	35.6	2.87	25.8	3.6	35.6	2.7	6.1	92.6	37.8	2.90	27.9	3.8	35.2	5.6	12.9	93.3	39.9	2.93	29.9	4.0	34.9	8.6	19.8			
		9.0	88.1	36.2	2.77	26.8	3.8	35.4	2.7	6.1	88.5	38.5	2.82	28.8	4.0	35.0	5.6	12.9	89.0	40.7	2.88	30.8	4.1	34.7	8.6	19.8			
		12.0	86.1	36.9	2.67	27.7	4.0	35.2	2.7	6.1	86.5	39.1	2.74	29.8	4.2	34.9	5.6	12.9	86.9	41.4	2.82	31.8	4.3	34.5	8.6	19.8			
	50	6.0	93.5	40.5	2.92	30.5	4.1	44.8	2.6	6.0	94.4	43.3	2.96	33.2	4.3	44.3	5.5	12.6	95.4	46.1	3.00	35.9	4.5	43.8	8.3	19.2			
		9.0	89.1	41.0	2.82	31.4	4.3	44.6	2.6	6.0	89.7	43.8	2.87	34.0	4.5	44.2	5.5	12.6	90.4	46.6	2.92	36.6	4.7	43.7	8.3	19.2			
		12.0	86.9	41.6	2.72	32.3	4.5	44.5	2.6	6.0	87.4	44.3	2.78	34.8	4.7	44.0	5.5	12.6	87.8	47.1	2.84	37.4	4.9	43.6	8.3	19.2			
	60	6.0	95.1	45.3	2.97	35.2	4.5	54.0	2.4	5.5	96.3	48.8	3.01	38.5	4.7	53.4	5.2	12.0	97.4	52.2	3.06	41.8	5.0	52.8	8.0	18.4			
		9.0	90.2	45.8	2.87	36.0	4.7	53.8	2.4	5.5	90.9	49.2	2.91	39.2	4.9	53.3	5.2	12.0	91.7	52.5	2.96	42.4	5.2	52.7	8.0	18.4			
		12.0	87.7	46.3	2.78	36.8	4.9	53.7	2.4	5.5	88.3	49.5	2.81	39.9	5.2	53.1	5.2	12.0	88.8	52.8	2.85	43.1	5.4	52.6	8.0	18.4			
	70	6.0	96.7	50.1	3.02	39.9	4.9	63.2	2.2	5.1	98.1	54.3	3.07	43.8	5.2	62.5	4.9	11.3	99.5	58.4	3.13	47.7	5.5	61.8	7.6	17.6			
		9.0	91.2	50.6	2.92	40.6	5.1	63.0	2.2	5.1	92.1	54.5	2.96	44.4	5.4	62.4	4.9	11.3	93.0	58.5	3.00	48.2	5.7	61.7	7.6	17.6			
		12.0	88.5	51.0	2.83	41.3	5.3	62.9	2.2	5.1	89.1	54.8	2.85	45.0	5.6	62.3	4.9	11.3	89.8	58.5	2.87	48.7	6.0	61.6	7.6	17.6			
	100	30	6.0	110.1	30.3	3.61	18.0	2.5	26.9	2.7	6.2	110.6	31.9	3.64	19.4	2.6	26.7	5.8	13.3	111.1	33.4	3.67	20.9	2.7	26.4	8.8	20.3		
			9.0	106.9	30.9	3.52	18.9	2.6	26.7	2.7	6.2	107.2	32.6	3.58	20.4	2.7	26.5	5.8	13.3	107.6	34.2	3.64	21.8	2.8	26.3	8.8	20.3		
			12.0	105.3	31.6	3.42	19.9	2.7	26.6	2.7	6.2	105.5	33.3	3.51	21.3	2.8	26.3	5.8	13.3	105.8	35.0	3.60	22.7	2.9	26.1	8.8	20.3		
40		6.0	111.7	35.0	3.66	22.5	2.8	36.1	2.7	6.1	112.4	37.1	3.70	24.5	2.9	35.8	5.6	12.9	113.1	39.2	3.74	26.4	3.1	35.5	8.6	19.8			
		9.0	107.9	35.6	3.57	23.4	2.9	36.0	2.7	6.1	108.4	37.7	3.62	25.4	3.1	35.6	5.6	12.9	108.9	39.9	3.68	27.3	3.2	35.3	8.6	19.8			
		12.0	106.0	36.1	3.47	24.3	3.1	35.8	2.7	6.1	106.4	38.4	3.55	26.3	3.2	35.5	5.6	12.9	106.8	40.6	3.63	28.2	3.3	35.1	8.6	19.8			
50		6.0	113.2	39.7	3.72	27.0	3.1	45.4	2.6	6.0	114.1	42.3	3.76	29.5	3.3	44.9	5.5	12.6	115.0	45.0	3.81	32.0	3.5	44.5	8.3	19.2			
		9.0	108.9	40.2	3.61	27.9	3.3	45.2	2.6	6.0	109.5	42.9	3.67	30.4	3.4	44.8	5.5	12.6	110.1	45.6	3.73	32.8	3.6	44.4	8.3	19.2			
		12.0	106.8	40.7	3.51	28.7	3.4	45.1	2.6	6.0	107.2	43.4	3.58	31.2	3.6	44.6	5.5	12.6	107.7	46.2	3.65	33.7	3.7	44.2	8.3	19.2			
60		6.0	114.8	44.5	3.77	31.6	3.5	54.6	2.4	5.5	115.9	47.6	3.83	34.5	3.6	54.1	5.2	12.0	116.9	50.7	3.88	37.5	3.8	53.6	8.0	18.4			
		9.0	110.0	44.8	3.66	32.3	3.6	54.4	2.4	5.5	110.7	48.0	3.72	35.3	3.8	53.9	5.2	12.0	111.4	51.3	3.78	38.4	4.0	53.4	8.0	18.4			
		12.0	107.5	45.2	3.55	33.1	3.7	54.3	2.4	5.5	108.1	48.5	3.62	36.2	3.9	53.8	5.2	12.0	108.6	51.8	3.68	39.2	4.1	53.3	8.0	18.4			
70		6.0	116.4	49.2	3.82	36.1	3.8	63.8	2.2	5.1	117.6	52.8	3.89	39.6	4.0	63.2	4.9	11.3	118.8	56.5	3.95	43.0	4.2	62.6	7.6	17.6			
		9.0	111.0	49.5	3.71	36.8	3.9	63.7	2.2	5.1	111.8	53.2	3.77	40.3	4.1	63.1	4.9	11.3	112.7	56.9	3.83	43.9	4.4	62.5	7.6	17.6			
		12.0	108.3	49.8	3.60	37.5	4.1	63.6	2.2	5.1	108.9	53.6	3.65	41.1	4.3	62.9	4.9	11.3	109.6	57.4	3.71	44.7	4.5	62.3	7.6	17.6			
120		30	6.0	129.9	29.8	4.41	14.8	2.0	27.5	2.7	6.2	130.5	31.4	4.44	16.3	2.1	27.2	5.8	13.3	131.0	33.0	4.48	17.7	2.2	27.0	8.8	20.3		
			9.0	126.8	30.4	4.32	15.7	2.1	27.3	2.7	6.2	127.1	32.0	4.38	17.1	2.1	27.1	5.8	13.3	127.5	33.7	4.43	18.6	2.2	26.8	8.8	20.3		
			12.0	125.2	31.0	4.23	16.5	2.1	27.2	2.7	6.2	125.4	32.7	4.31	18.0	2.2	26.9	5.8	13.3	125.7	34.4	4.39	19.4	2.3	26.7	8.8	20.3		
	40	6.0	131.5	34.4	4.46	19.2	2.3	36.7	2.7	6.1	132.1	36.4	4.51	21.0	2.4	36.4	5.6	12.9	132.8	38.4	4.55	22.9	2.5	36.1	8.6	19.8			
		9.0	127.8	34.9	4.36	20.0	2.3	36.6	2.7	6.1	128.2	37.0	4.43	21.9	2.4	36.2	5.6	12.9	128.7	39.1	4.49	23.8	2.6	35.9	8.6	19.8			
		12.0	125.9	35.4	4.27	20.8	2.4	36.4	2.7	6.1	126.3	37.6	4.35	22.8	2.5	36.1	5.6	12.9	126.6	39.8	4.43	24.7	2.6	35.8	8.6	19.8			
	50	6.0	133.0	39.0	4.52	23.6	2.5	45.9	2.6	6.0	133.8	41.4	4.57	25.8	2.7	45.6	5.5	12.6	134.6	43.8	4.62	28.0	2.8	45.2	8.3	19.2			
		9.0	128.8	39.4	4.41	24.3	2.6	45.8	2.6	6.0	129.3	42.0	4.48	26.7	2.7	45.4	5.5	12.6	129.9	44.6	4.55	29.0	2.9	45.0	8.3	19.2			
		12.0	126.6	39.8	4.30	25.1	2.7	45.7	2.6	6.0	127.1	42.5	4.38	27.6	2.8	45.3	5.5	12.6	127.5	45.3	4.47	30.0	3.0	44.8	8.3	19.2			
	60	6.0	134.5	43.6	4.58	28.0	2.8	55.2	2.4	5.5	135.5	46.4	4.64	30.6	2.9	54.7	5.2	12.0	136.4	49.2	4.70	33.2	3.1	54.3	8.0	18.4			
		9.0	129.8	43.9	4.45	28.7	2.9	55.1	2.4	5.5	130.4	46.9	4.53	31.5	3.0	54.6	5.2	12.0	131.1	50.0	4.60	34.3	3.2	54.1	8.0	18.4			
		12.0	127.4	44.2	4.33	29.4	3.0	54.9	2.4	5.5	127.9	47.5	4.42	32.4	3.1	54.4	5.2	12.0	128.5	50.7	4.51	35.3	3.3	53.9	8.0	18.4			
	70	6.0	136.1	48.2	4.63	32.4	3.0	64.4	2.2	5.1	137.1	51.4	4.70	35.4	3.2	63.9	4.9	11.3	138.2	54.7	4.77	38.4	3.4	63.4	7.6	17.6			
		9.0	130.8	48.4	4.50	33.0	3.2	64.3	2.2	5.1	131.5	51.9	4.58	36.3	3.3	63.8	4.9	11.3	132.3	55.4	4.66	39.5	3.5	63.2	7.6	17.6			
		12.0	128.1	48.6	4.36	33.7	3.3	64.2	2.2	5.1	128.7	52.4	4.46	37.2	3.4	63.6	4.9	11.3	129.4	56.2	4.55	40.7	3.6	63.0	7.6	17.6			

Notes: Multiple Flow Rates for Source Side and Load Side are shown. When selecting units and designing the system, actual operating parameters must fall within the temperature and flow rate ranges shown on the table. Using temperature/flow rate combinations outside the range of the table will result in performance problems.

RTV056

Heating and Cooling Capacity Data

EWT	GPM	WPD		CFM	HEATING ONLY				
		PSI	FT		HC	KW	HE	LAT	COP
30	8.0	3.6	8.3	1100	40.8	3.61	28.4	104.3	3.31
				1800	42.7	3.53	30.6	92.0	3.54
	11.0	5.6	12.9	1100	42.4	3.68	29.9	105.7	3.38
				1800	43.6	3.54	31.5	92.4	3.61
	14.0	7.9	18.2	1100	43.8	3.72	31.1	106.9	3.45
				1800	44.7	3.58	32.5	93.0	3.66
50	8.0	3.4	7.9	1100	53.3	4.19	39.0	114.9	3.73
				1800	56.2	3.83	43.1	98.9	4.29
	11.0	5.4	12.5	1100	54.9	4.23	40.4	116.2	3.80
				1800	57.8	3.87	44.6	99.7	4.37
	14.0	7.7	17.8	1100	56.5	4.28	41.9	117.6	3.87
				1800	59.1	3.90	45.8	100.4	4.44
70	8.0	3.3	7.2	1100	67.8	4.66	51.9	127.1	4.26
				1800	70.6	4.15	56.4	106.3	4.98
	11.0	5.1	11.8	1100	69.9	4.75	53.7	128.8	4.31
				1800	73.0	4.22	58.6	107.6	5.07
	14.0	7.3	16.9	1100	71.6	4.80	55.2	130.2	4.37
				1800	74.6	4.24	60.1	108.4	5.15
90	8.0	3.1	7.2	1100	80.0	5.29	61.9	137.3	4.43
				1800	84.6	4.51	69.2	113.5	5.49
	11.0	5.0	11.6	1100	81.9	5.36	63.7	139.0	4.48
				1800	87.1	4.58	71.5	114.8	5.57
	14.0	6.9	15.9	1100	83.8	5.41	65.3	140.5	4.54
				1800	89.8	4.64	73.9	116.2	5.67

EWT	GPM	WPD		CFM	COOLING ONLY				
		PSI	FT		TC	SC	KW	HR	EER
50	8.0	3.4	7.9	1100	56.3	35.3	2.57	65.1	21.9
				1400	57.5	38.5	2.66	66.6	21.6
	11.0	5.4	12.5	1100	56.9	35.5	2.52	65.5	22.6
				1400	58.1	38.7	2.60	67.0	22.4
	14.0	7.7	17.8	1100	57.5	35.7	2.47	65.9	23.3
				1400	58.7	38.9	2.55	67.4	23.0
1800	59.5	42.5	2.84	69.2	21.0				
			2.78	69.6	21.6				
70	8.0	3.3	7.2	1100	54.1	33.9	3.18	64.9	17.0
				1400	55.7	37.1	3.32	67.1	16.8
	11.0	5.1	11.8	1100	54.7	34.2	3.06	65.2	17.9
				1400	56.4	37.5	3.20	67.3	17.6
	14.0	7.3	16.9	1100	55.4	34.8	3.00	65.7	18.5
				1400	57.2	38.0	3.13	67.9	18.2
1800	59.0	42.3	3.35	70.4	17.6				
90	8.0	3.1	7.2	1100	49.1	31.9	3.95	62.6	12.4
				1400	51.1	35.0	4.16	65.3	12.3
	11.0	5.0	11.6	1100	49.8	32.4	3.75	62.6	13.3
				1400	51.8	35.6	3.95	65.3	13.1
	14.0	6.9	15.9	1100	50.6	33.2	3.68	63.2	13.8
				1400	52.7	36.5	3.88	65.9	13.6
1800	54.8	41.0	4.06	68.7	13.5				
110	8.0	3.0	6.9	1100	43.2	28.3	4.68	59.2	9.2
				1400	45.4	31.2	5.03	62.6	9.0
	11.0	4.9	11.2	1100	43.8	29.9	4.39	58.8	10.0
				1400	46.1	33.0	4.71	62.2	9.8
	14.0	6.7	15.5	1100	48.3	37.5	5.04	65.5	9.6
				1400	44.8	30.9	4.30	59.4	10.4
1800	47.1	34.1	4.62	62.8	10.2				
1800	49.3	38.7	4.94	66.2	10.0				

Notes: Multiple Flow Rates (for EWT) are shown in the tables above. The lowest flow rate shown is used for geothermal open loop/well water systems with a minimum 50° F. The second flow rate shown is the minimum geothermal closed loop flow rate. The third rate shown is optimum for geothermal closed loop and the suggested flow rate for boiler tower applications.

RTV056

Water Heating Data (Load Pump Watts Included)

ELT	EST	LGPM	SOURCE 8.0 GPM							SWPD		SOURCE 11.0 GPM							SWPD		SOURCE 14.0 GPM							SWPD	
			LLT	HC	KW	HE	COP	LST	PSI	FT HD	LLT	HC	KW	HE	COP	LST	PSI	FT HD	LLT	HC	KW	HE	COP	LST	PSI	FT HD			
80	30	8.0	88.6	43.0	3.42	31.3	3.7	23.5	3.6	8.3	88.8	43.8	3.43	32.1	3.7	24.7	5.8	13.3	88.9	44.5	3.43	32.8	3.8	25.8	7.9	18.2			
		11.0	86.5	42.0	3.36	30.5	3.7	23.7	3.6	8.3	86.6	43.2	3.37	31.7	3.8	24.7	5.8	13.3	86.8	44.4	3.37	32.9	3.9	25.8	7.9	18.2			
		14.0	85.1	40.9	3.29	29.7	3.6	23.9	3.6	8.3	85.3	42.7	3.31	31.4	3.8	24.8	5.8	13.3	85.5	44.4	3.32	33.1	3.9	25.7	7.9	18.2			
	40	8.0	90.0	49.8	3.51	37.8	4.2	32.2	3.5	8.1	90.2	50.9	3.51	39.0	4.3	33.5	5.7	13.1	90.4	52.1	3.50	40.1	4.4	34.8	7.8	18.0			
		11.0	87.5	48.8	3.42	37.2	4.2	32.3	3.5	8.1	87.7	50.4	3.43	38.7	4.3	33.6	5.7	13.1	88.0	51.9	3.43	40.2	4.4	34.8	7.8	18.0			
		14.0	86.0	47.9	3.33	36.6	4.2	32.5	3.5	8.1	86.2	49.8	3.35	38.4	4.4	33.6	5.7	13.1	86.5	51.7	3.36	40.2	4.5	34.8	7.8	18.0			
	50	8.0	91.3	56.5	3.60	44.2	4.6	40.9	3.4	7.9	91.6	58.1	3.59	45.8	4.7	42.4	5.6	12.8	91.9	59.7	3.58	47.4	4.9	43.9	7.7	17.8			
		11.0	88.6	55.7	3.48	43.8	4.7	41.0	3.4	7.9	88.8	57.5	3.48	45.6	4.8	42.4	5.6	12.8	89.1	59.3	3.49	47.4	5.0	43.9	7.7	17.8			
		14.0	86.9	55.0	3.37	43.5	4.8	41.0	3.4	7.9	87.1	57.0	3.38	45.4	4.9	42.5	5.6	12.8	87.4	58.9	3.40	47.3	5.1	43.9	7.7	17.8			
	60	8.0	92.6	63.2	3.68	50.7	5.0	49.6	3.4	7.7	93.0	65.2	3.67	52.7	5.2	51.2	5.4	12.5	93.4	67.2	3.65	54.8	5.4	52.9	7.5	17.3			
		11.0	89.6	62.6	3.54	50.5	5.2	49.6	3.4	7.7	89.9	64.7	3.54	52.6	5.3	51.3	5.4	12.5	90.3	66.7	3.55	54.6	5.5	53.0	7.5	17.3			
		14.0	87.8	62.0	3.40	50.4	5.3	49.6	3.4	7.7	88.0	64.1	3.42	52.4	5.5	51.3	5.4	12.5	88.3	66.2	3.44	54.5	5.6	53.0	7.5	17.3			
	70	8.0	94.0	70.0	3.77	57.1	5.4	58.2	3.3	7.6	94.5	72.4	3.75	59.6	5.7	60.1	5.3	12.2	95.0	74.8	3.73	62.1	5.9	62.0	7.3	16.9			
		11.0	90.7	69.5	3.60	57.2	5.6	58.2	3.3	7.6	91.0	71.8	3.60	59.5	5.8	60.1	5.3	12.2	91.4	74.1	3.60	61.8	6.0	62.0	7.3	16.9			
		14.0	88.6	69.0	3.44	57.3	5.9	58.2	3.3	7.6	88.9	71.3	3.46	59.5	6.0	60.1	5.3	12.2	89.2	73.5	3.48	61.6	6.2	62.1	7.3	16.9			
	100	30	8.0	108.5	42.5	4.40	27.5	2.8	24.3	3.6	8.3	108.7	43.3	4.41	28.3	2.9	25.3	5.8	13.3	108.8	44.1	4.42	29.1	2.9	26.3	7.9	18.2		
			11.0	106.5	41.9	4.31	27.2	2.8	24.4	3.6	8.3	106.6	43.0	4.34	28.2	2.9	25.3	5.8	13.3	106.8	44.0	4.37	29.1	3.0	26.2	7.9	18.2		
			14.0	105.2	41.4	4.23	26.9	2.9	24.4	3.6	8.3	105.3	42.6	4.27	28.0	2.9	25.3	5.8	13.3	105.5	43.9	4.31	29.2	3.0	26.2	7.9	18.2		
40		8.0	109.8	49.2	4.48	33.9	3.2	33.0	3.5	8.1	110.1	50.3	4.49	35.0	3.3	34.2	5.7	13.1	110.3	51.5	4.49	36.1	3.4	35.3	7.8	18.0			
		11.0	107.5	48.7	4.38	33.7	3.3	33.0	3.5	8.1	107.7	50.0	4.40	35.0	3.3	34.2	5.7	13.1	107.9	51.3	4.42	36.2	3.4	35.3	7.8	18.0			
		14.0	106.0	48.1	4.27	33.5	3.3	33.1	3.5	8.1	106.2	49.6	4.31	34.9	3.4	34.2	5.7	13.1	106.4	51.1	4.34	36.3	3.4	35.3	7.8	18.0			
50		8.0	111.2	55.9	4.56	40.3	3.6	41.7	3.4	7.9	111.5	57.3	4.57	41.7	3.7	43.1	5.6	12.8	111.8	58.8	4.57	43.2	3.8	44.4	7.7	17.8			
		11.0	108.5	55.4	4.44	40.2	3.7	41.7	3.4	7.9	108.8	57.0	4.46	41.8	3.7	43.1	5.6	12.8	109.0	58.5	4.47	43.3	3.8	44.4	7.7	17.8			
		14.0	106.9	54.9	4.32	40.2	3.7	41.7	3.4	7.9	107.1	56.6	4.34	41.8	3.8	43.1	5.6	12.8	107.3	58.3	4.37	43.4	3.9	44.4	7.7	17.8			
60		8.0	112.5	62.5	4.64	46.7	3.9	50.4	3.4	7.7	112.9	64.3	4.65	48.5	4.1	51.9	5.4	12.5	113.2	66.1	4.65	50.2	4.2	53.5	7.5	17.3			
		11.0	109.6	62.1	4.50	46.7	4.0	50.4	3.4	7.7	109.8	64.0	4.51	48.6	4.2	51.9	5.4	12.5	110.1	65.8	4.53	50.4	4.3	53.5	7.5	17.3			
		14.0	107.7	61.7	4.36	46.8	4.1	50.4	3.4	7.7	107.9	63.6	4.38	48.6	4.3	51.9	5.4	12.5	108.2	65.5	4.40	50.5	4.4	53.5	7.5	17.3			
70		8.0	113.8	69.2	4.73	53.1	4.3	59.1	3.3	7.6	114.3	71.3	4.73	55.2	4.4	60.8	5.3	12.2	114.7	73.4	4.73	57.3	4.5	62.6	7.3	16.9			
		11.0	110.6	68.9	4.57	53.3	4.4	59.0	3.3	7.6	110.9	71.0	4.57	55.4	4.5	60.8	5.3	12.2	111.2	73.1	4.58	57.4	4.7	62.6	7.3	16.9			
		14.0	108.6	68.5	4.41	53.4	4.6	59.0	3.3	7.6	108.8	70.6	4.42	55.5	4.7	60.8	5.3	12.2	109.1	72.7	4.43	57.6	4.8	62.6	7.3	16.9			
120		30	8.0	128.4	42.0	5.37	23.7	2.3	25.1	3.6	8.3	128.6	42.9	5.39	24.5	2.3	25.9	5.8	13.3	128.8	43.8	5.41	25.3	2.4	26.7	7.9	18.2		
			11.0	126.4	41.9	5.27	23.9	2.3	25.1	3.6	8.3	126.6	42.7	5.31	24.6	2.4	25.9	5.8	13.3	126.7	43.6	5.36	25.3	2.4	26.7	7.9	18.2		
			14.0	125.2	41.8	5.16	24.2	2.4	25.0	3.6	8.3	125.3	42.6	5.23	24.7	2.4	25.9	5.8	13.3	125.4	43.4	5.31	25.3	2.4	26.7	7.9	18.2		
	40	8.0	129.7	48.6	5.45	30.0	2.6	33.8	3.5	8.1	129.9	49.7	5.47	31.1	2.7	34.8	5.7	13.1	130.2	50.8	5.49	32.1	2.7	35.9	7.8	18.0			
		11.0	127.5	48.5	5.33	30.3	2.7	33.8	3.5	8.1	127.6	49.6	5.37	31.2	2.7	34.8	5.7	13.1	127.8	50.7	5.41	32.2	2.7	35.8	7.8	18.0			
		14.0	126.0	48.3	5.22	30.5	2.7	33.7	3.5	8.1	126.2	49.4	5.27	31.4	2.7	34.8	5.7	13.1	126.3	50.5	5.32	32.3	2.8	35.8	7.8	18.0			
	50	8.0	131.0	55.2	5.53	36.4	2.9	42.5	3.4	7.9	131.3	56.6	5.55	37.6	3.0	43.7	5.6	12.8	131.6	57.9	5.57	38.9	3.0	45.0	7.7	17.8			
		11.0	128.5	55.0	5.40	36.6	3.0	42.4	3.4	7.9	128.7	56.4	5.43	37.9	3.0	43.7	5.6	12.8	128.9	57.8	5.46	39.2	3.1	45.0	7.7	17.8			
		14.0	126.9	54.9	5.27	36.9	3.0	42.4	3.4	7.9	127.0	56.2	5.31	38.1	3.1	43.7	5.6	12.8	127.2	57.6	5.34	39.4	3.2	44.9	7.7	17.8			
	60	8.0	132.4	61.9	5.61	42.7	3.2	51.2	3.4	7.7	132.7	63.4	5.63	44.2	3.3	52.6	5.4	12.5	133.0	65.0	5.65	45.7	3.4	54.1	7.5	17.3			
		11.0	129.5	61.6	5.46	43.0	3.3	51.1	3.4	7.7	129.7	63.3	5.49	44.5	3.4	52.6	5.4	12.5	130.0	64.9	5.51	46.1	3.5	54.1	7.5	17.3			
		14.0	127.7	61.4	5.32	43.2	3.4	51.1	3.4	7.7	127.9	63.1	5.34	44.9	3.5	52.5	5.4	12.5	128.1	64.8	5.36	46.5	3.5	54.0	7.5	17.3			
	70	8.0	133.7	68.5	5.69	49.1	3.5	59.9	3.3	7.6	134.1	70.3	5.71	50.8	3.6	61.6	5.3	12.2	134.4	72.1	5.73	52.5	3.7	63.2	7.3	16.9			
		11.0	130.5	68.2	5.53	49.3	3.6	59.8	3.3	7.6	130.8	70.1	5.54	51.2	3.7	61.5	5.3	12.2	131.1	72.0	5.56	53.0	3.8	63.2	7.3	16.9			
		14.0	128.5	67.9	5.38	49.6	3.7	59.8	3.3	7.6	128.7	69.9	5.38	51.6	3.8	61.4	5.3	12.2	129.0	71.9	5.38	53.6	3.9	63.1	7.3	16.9			

Notes: Multiple Flow Rates for Source Side and Load Side are shown. When selecting units and designing the system, actual operating parameters must fall within the temperature and flow rate ranges shown on the table. Using temperature/flow rate combinations outside the range of the table will result in performance problems.

RTV066

Heating and Cooling Capacity Data

EWT	GPM	WPD		CFM	HEATING ONLY				
		PSI	FT		HC	KW	HE	LAT	COP
30	10.0	4.3	9.9	1400	47.4	4.29	32.7	101.3	3.23
				2200	50.4	4.23	36.0	91.2	3.49
	13.0	7.0	16.2	1400	49.8	4.40	34.8	103.0	3.32
				2200	51.2	4.25	36.7	91.6	3.53
	16.0	10.7	24.7	1400	51.3	4.44	36.1	103.9	3.38
				2200	52.1	4.27	37.5	91.9	3.57
50	10.0	4.0	9.2	1400	63.4	5.10	46.0	111.9	3.65
				2200	67.3	4.61	51.6	98.3	4.28
	13.0	6.7	15.5	1400	65.5	5.15	47.9	113.3	3.73
				2200	68.8	4.65	53.0	99.0	4.34
	16.0	10.3	23.8	1400	67.7	5.23	49.9	114.8	3.80
				2200	70.0	4.68	54.1	99.5	4.39
70	10.0	3.5	8.1	1400	81.3	5.77	61.7	123.8	4.13
				2200	83.6	5.14	66.1	105.2	4.77
	13.0	5.8	13.4	1400	83.0	5.82	63.2	124.9	4.18
				2200	86.0	5.21	68.2	106.2	4.84
	16.0	8.9	20.6	1400	84.8	5.87	64.8	126.1	4.23
				2200	87.6	5.24	69.7	106.9	4.89
90	10.0	3.4	7.9	1400	96.0	6.47	73.9	133.5	4.35
				2200	98.2	5.58	79.1	111.3	5.16
	13.0	5.6	12.9	1400	99.2	6.57	76.8	135.6	4.43
				2200	101.6	5.68	82.2	112.8	5.24
	16.0	8.6	19.9	1400	102.4	6.67	79.6	137.7	4.50
				2200	103.5	5.72	84.0	113.6	5.30

EWT	GPM	WPD		CFM	COOLING ONLY				
		PSI	FT		TC	SC	KW	HR	EER
50	10.0	4.0	9.2	1400	60.0	37.0	3.22	71.0	18.6
				1700	62.8	40.4	3.46	74.7	18.1
	13.0	6.7	15.5	1400	60.3	37.2	3.19	71.2	18.9
				1700	63.3	40.6	3.43	75.0	18.5
	16.0	10.3	23.8	1400	61.1	37.4	3.16	71.9	19.4
				1700	64.1	40.8	3.39	75.6	18.9
2200			65.7	46.7	3.64	78.1	18.0		
	70	10.0	3.5	8.1	1400	59.0	35.4	3.86	72.2
1700					61.4	40.1	4.10	75.4	15.0
13.0		5.8	13.4	1400	59.4	35.5	3.78	72.2	15.7
				1700	62.0	40.1	4.02	75.7	15.4
16.0		8.9	20.6	1400	60.3	36.2	3.72	73.0	16.2
				1700	62.9	41.0	3.96	76.4	15.9
2200			65.5	47.0	4.24	80.0	15.5		
90	10.0	3.4	7.9	1400	57.1	35.1	4.87	73.7	11.7
				1700	57.4	39.2	4.99	74.4	11.5
	13.0	5.6	12.9	1400	60.7	45.0	5.31	78.8	11.4
				1700	57.7	35.0	4.72	73.8	12.2
	16.0	8.6	19.9	1400	58.0	39.1	4.82	74.5	12.0
				1700	61.3	44.9	5.14	78.9	11.9
2200			58.7	36.4	4.62	74.5	12.7		
110	10.0	3.3	7.6	1400	51.3	32.0	5.91	71.5	8.7
				1700	52.5	36.2	6.15	73.5	8.5
	13.0	5.4	12.5	1400	54.2	41.6	6.53	76.4	8.3
				1700	51.9	31.8	5.66	71.3	9.2
	16.0	8.3	19.3	1400	53.1	36.0	5.89	73.2	9.0
				1700	54.9	41.3	6.25	76.2	8.8
2200			53.0	33.7	5.52	71.8	9.6		
2200			54.2	38.1	5.75	73.8	9.4		
2200			56.0	43.8	6.10	76.8	9.2		

Notes: Multiple Flow Rates (for EWT) are shown in the tables above. The lowest flow rate shown is used for geothermal open loop/well water systems with a minimum 50° F. The second flow rate shown is the minimum geothermal closed loop flow rate. The third rate shown is optimum for geothermal closed loop and the suggested flow rate for boiler tower applications.

RTV066

Water Heating Data (Load Pump Watts Included)

ELT	EST	LGPM	SOURCE 10.0 GPM							SWPD		SOURCE 13.0 GPM							SWPD		SOURCE 16.0 GPM							SWPD	
			LLT	HC	KW	HE	COP	LST	PSI	FT HD	LLT	HC	KW	HE	COP	LST	PSI	FT HD	LLT	HC	KW	HE	COP	LST	PSI	FT HD			
80	30	10.0	90.1	50.4	4.31	35.7	3.4	22.6	4.3	9.9	90.3	51.4	4.32	36.7	3.5	23.9	7.5	17.3	90.5	52.4	4.33	37.6	3.5	25.1	10.7	24.7			
		13.0	87.7	50.2	4.23	35.8	3.5	22.6	4.3	9.9	87.9	51.1	4.24	36.7	3.5	23.9	7.5	17.3	88.0	52.0	4.24	37.5	3.6	25.2	10.7	24.7			
		16.0	86.3	50.0	4.16	35.8	3.5	22.6	4.3	9.9	86.4	50.8	4.15	36.6	3.6	23.9	7.5	17.3	86.5	51.6	4.15	37.5	3.6	25.2	10.7	24.7			
	40	10.0	91.6	57.8	4.38	42.8	3.9	31.2	4.2	9.6	91.8	59.2	4.40	44.2	3.9	32.7	7.3	16.9	92.1	60.6	4.41	45.5	4.0	34.1	10.5	24.3			
		13.0	88.8	57.5	4.28	42.8	3.9	31.2	4.2	9.6	89.1	58.8	4.30	44.2	4.0	32.7	7.3	16.9	89.3	60.2	4.31	45.5	4.1	34.1	10.5	24.3			
		16.0	87.1	57.1	4.19	42.8	4.0	31.2	4.2	9.6	87.3	58.5	4.20	44.2	4.1	32.7	7.3	16.9	87.5	59.9	4.21	45.5	4.2	34.1	10.5	24.3			
	50	10.0	93.0	65.1	4.44	50.0	4.3	39.7	4.0	9.2	93.4	66.9	4.47	51.7	4.4	41.4	7.2	16.5	93.7	68.7	4.50	53.4	4.5	43.1	10.3	23.8			
		13.0	90.0	64.7	4.34	49.9	4.4	39.7	4.0	9.2	90.2	66.6	4.36	51.7	4.5	41.4	7.2	16.5	90.5	68.4	4.39	53.5	4.6	43.1	10.3	23.8			
		16.0	88.0	64.3	4.23	49.8	4.5	39.7	4.0	9.2	88.3	66.2	4.25	51.7	4.6	41.4	7.2	16.5	88.5	68.2	4.28	53.6	4.7	43.1	10.3	23.8			
	60	10.0	94.5	72.5	4.51	57.1	4.7	48.2	3.8	8.7	94.9	74.7	4.54	59.2	4.8	50.2	6.7	15.4	95.4	76.9	4.58	61.2	4.9	52.1	9.6	22.2			
		13.0	91.1	71.9	4.39	57.0	4.8	48.3	3.8	8.7	91.4	74.3	4.42	59.2	4.9	50.2	6.7	15.4	91.8	76.7	4.46	61.4	5.0	52.1	9.6	22.2			
		16.0	88.9	71.4	4.27	56.8	4.9	48.3	3.8	8.7	89.2	73.9	4.30	59.2	5.0	50.2	6.7	15.4	89.6	76.4	4.34	61.6	5.2	52.1	9.6	22.2			
	70	10.0	96.0	79.8	4.58	64.2	5.1	56.8	3.5	8.1	96.5	82.4	4.62	66.7	5.2	58.9	6.2	14.3	97.0	85.0	4.66	69.1	5.3	61.1	8.9	20.6			
		13.0	92.2	79.2	4.44	64.0	5.2	56.8	3.5	8.1	92.6	82.0	4.48	66.7	5.4	58.9	6.2	14.3	93.1	84.9	4.53	69.4	5.5	61.1	8.9	20.6			
		16.0	89.8	78.5	4.30	63.8	5.3	56.8	3.5	8.1	90.2	81.6	4.35	66.8	5.5	58.9	6.2	14.3	90.6	84.7	4.40	69.7	5.6	61.0	8.9	20.6			
100	30	10.0	110.1	50.4	5.62	31.2	2.6	23.6	4.3	9.9	110.2	51.2	5.61	32.1	2.7	24.7	7.5	17.3	110.4	52.1	5.60	33.0	2.7	25.8	10.7	24.7			
		13.0	107.8	50.4	5.51	31.6	2.7	23.5	4.3	9.9	107.9	51.2	5.51	32.4	2.7	24.6	7.5	17.3	108.0	52.0	5.51	33.2	2.8	25.7	10.7	24.7			
		16.0	106.3	50.4	5.41	32.0	2.7	23.4	4.3	9.9	106.4	51.2	5.42	32.7	2.8	24.5	7.5	17.3	106.5	52.0	5.43	33.5	2.8	25.7	10.7	24.7			
	40	10.0	111.6	57.8	5.70	38.4	3.0	32.1	4.2	9.6	111.8	58.8	5.67	39.5	3.0	33.4	7.3	16.9	112.0	59.8	5.64	40.5	3.1	34.8	10.5	24.3			
		13.0	108.9	57.7	5.58	38.7	3.0	32.0	4.2	9.6	109.0	58.8	5.57	39.8	3.1	33.4	7.3	16.9	109.2	59.9	5.56	40.9	3.2	34.7	10.5	24.3			
		16.0	107.2	57.6	5.45	39.0	3.1	32.0	4.2	9.6	107.4	58.8	5.47	40.1	3.1	33.3	7.3	16.9	107.5	60.0	5.49	41.3	3.2	34.7	10.5	24.3			
	50	10.0	113.1	65.3	5.78	45.6	3.3	40.6	4.0	9.2	113.3	66.4	5.73	46.8	3.4	42.2	7.2	16.5	113.5	67.4	5.68	48.1	3.5	43.8	10.3	23.8			
		13.0	110.0	65.0	5.64	45.8	3.4	40.6	4.0	9.2	110.2	66.4	5.63	47.2	3.5	42.1	7.2	16.5	110.4	67.8	5.62	48.6	3.5	43.7	10.3	23.8			
		16.0	108.1	64.8	5.50	46.0	3.5	40.5	4.0	9.2	108.3	66.4	5.53	47.6	3.5	42.1	7.2	16.5	108.5	68.1	5.55	49.1	3.6	43.7	10.3	23.8			
	60	10.0	114.5	72.7	5.86	52.7	3.6	49.1	3.8	8.7	114.8	73.9	5.79	54.2	3.7	51.0	6.7	15.4	115.0	75.1	5.72	55.6	3.8	52.8	9.6	22.2			
		13.0	111.1	72.4	5.70	52.9	3.7	49.1	3.8	8.7	111.4	74.0	5.68	54.6	3.8	50.9	6.7	15.4	111.6	75.6	5.67	56.3	3.9	52.7	9.6	22.2			
		16.0	109.0	72.0	5.55	53.0	3.8	49.1	3.8	8.7	109.3	74.1	5.58	55.0	3.9	50.9	6.7	15.4	109.5	76.1	5.61	57.0	4.0	52.7	9.6	22.2			
	70	10.0	116.0	80.2	5.94	59.9	4.0	57.6	3.5	8.1	116.3	81.5	5.85	61.5	4.1	59.8	6.2	14.3	116.6	82.8	5.76	63.2	4.2	61.9	8.9	20.6			
		13.0	112.3	79.7	5.77	60.0	4.0	57.6	3.5	8.1	112.6	81.6	5.74	62.0	4.2	59.7	6.2	14.3	112.8	83.5	5.72	64.0	4.3	61.8	8.9	20.6			
		16.0	109.9	79.2	5.60	60.1	4.1	57.6	3.5	8.1	110.2	81.7	5.64	62.5	4.2	59.6	6.2	14.3	110.5	84.2	5.68	64.8	4.3	61.6	8.9	20.6			
120	30	10.0	130.1	50.3	6.92	26.7	2.1	24.5	4.3	9.9	130.2	51.0	6.89	27.5	2.2	25.4	7.5	17.3	130.3	51.7	6.86	28.3	2.2	26.4	10.7	24.7			
		13.0	127.8	50.6	6.79	27.4	2.2	24.4	4.3	9.9	127.9	51.3	6.79	28.1	2.2	25.3	7.5	17.3	128.0	52.0	6.78	28.9	2.2	26.3	10.7	24.7			
		16.0	126.4	50.8	6.66	28.1	2.2	24.2	4.3	9.9	126.4	51.6	6.68	28.8	2.3	25.2	7.5	17.3	126.5	52.3	6.70	29.5	2.3	26.2	10.7	24.7			
	40	10.0	131.6	57.9	7.01	33.9	2.4	33.0	4.2	9.6	131.7	58.4	6.94	34.7	2.5	34.2	7.3	16.9	131.8	58.9	6.86	35.5	2.5	35.4	10.5	24.3			
		13.0	128.9	58.0	6.87	34.5	2.5	32.9	4.2	9.6	129.0	58.8	6.84	35.4	2.5	34.1	7.3	16.9	129.2	59.6	6.81	36.3	2.6	35.3	10.5	24.3			
		16.0	127.3	58.1	6.72	35.2	2.5	32.8	4.2	9.6	127.4	59.1	6.74	36.1	2.6	34.0	7.3	16.9	127.5	60.2	6.77	37.1	2.6	35.2	10.5	24.3			
	50	10.0	133.1	65.4	7.11	41.2	2.7	41.5	4.0	9.2	133.2	65.8	6.98	42.0	2.8	43.0	7.2	16.5	133.2	66.2	6.86	42.8	2.8	44.5	10.3	23.8			
		13.0	130.1	65.4	6.94	41.7	2.8	41.4	4.0	9.2	130.2	66.2	6.89	42.7	2.8	42.9	7.2	16.5	130.3	67.1	6.84	43.7	2.9	44.4	10.3	23.8			
		16.0	128.2	65.3	6.77	42.2	2.8	41.3	4.0	9.2	128.3	66.7	6.80	43.5	2.9	42.8	7.2	16.5	128.5	68.0	6.83	44.7	2.9	44.2	10.3	23.8			
	60	10.0	134.6	73.0	7.20	48.4	3.0	50.0	3.8	8.7	134.6	73.2	7.03	49.2	3.0	51.8	6.7	15.4	134.7	73.4	6.86	50.0	3.1	53.6	9.6	22.2			
		13.0	131.2	72.8	7.02	48.8	3.0	49.9	3.8	8.7	131.3	73.7	6.95	50.0	3.1	51.7	6.7	15.4	131.5	74.6	6.88	51.2	3.2	53.4	9.6	22.2			
		16.0	129.1	72.6	6.83	49.3	3.1	49.8	3.8	8.7	129.3	74.2	6.86	50.8	3.2	51.6	6.7	15.4	129.5	75.8	6.89	52.3	3.2	53.3	9.6	22.2			
	70	10.0	136.1	80.5	7.30	55.6	3.2	58.5	3.5	8.1	136.1	80.6	7.08	56.4	3.3	60.6	6.2	14.3	136.1	80.6	6.86	57.2	3.4	62.6	8.9	20.6			
		13.0	132.3	80.2	7.09	56.0	3.3	58.5	3.5	8.1	132.5	81.2	7.00	57.3	3.4	60.5	6.2	14.3	132.6	82.2	6.91	58.6	3.5	62.5	8.9	20.6			
		16.0	130.0	79.8	6.89	56.3	3.4	58.4	3.5	8.1	130.2	81.8	6.92	58.1	3.5	60.3	6.2	14.3	130.5	83.7	6.96	59.9	3.5	62.3	8.9	20.6			

Notes: Multiple Flow Rates for Source Side and Load Side are shown. When selecting units and designing the system, actual operating parameters must fall within the temperature and flow rate ranges shown on the table. Using temperature/flow rate combinations outside the range of the table will result in performance problems.

Engineering Guide Specifications

General

Synergy3 units shall be floor mounted type with horizontal air inlet and vertical up flow air discharge. Reverse cycle operation shall provide heating or cooling in the forced air mode. The unit shall also be capable of heating water for hydronic applications when the unit is not in the forced air mode. Units shall be ARI/ISO Standard 13256-1 (ground loop) performance certified and listed by a nationally recognized safety-testing laboratory or agency, such as ETL Testing Laboratory. Each unit shall be computer run-tested at the factory. Each unit shall be mounted on a pallet for shipping.

The geothermal units shall be designed to operate with entering liquid temperature between 25°F and 110°F.

Casing & Cabinet

The cabinet shall be fabricated from heavy-gauge steel and finished with corrosion-resistant epoxy powder coating. The interior shall be insulated with 1/2-inch thick, multi-density, coated acoustic liner with edges sealed or tucked under flanges to prevent the introduction of glass fibers into the discharge air. Two blower and two compressor compartment access panels shall be removable with supply and return ductwork in place. The internal component layout shall provide for service access from the front side for restricted installations. A divider panel separating the air handling and compressor compartments shall be easily removable for service access.

A duct collar shall be provided for the supply air opening. The units shall have an insulated divider panel between the air handling section and the compressor section to minimize the transmission of compressor noise and to permit operational service testing without air bypass. Units shall be supplied with left horizontal air inlet and top vertical air discharge.

Filter Rack

A return air filter rack and three standard-size 1-inch filters shall be provided with each unit at no additional cost.

Refrigerant Circuit

All units shall contain a sealed refrigerant circuit including: a hermetic motor-compressor, bidirectional thermal expansion valve, finned tube air-to-refrigerant heat exchanger solenoid valve, diverting valve, check valve, reversing valve, coaxial tube water-to-refrigerant heat exchanger, coaxial tube refrigerant-to-water heat exchanger, and service ports.

Compressors shall be high efficiency compliant scroll designed for heat pump duty and mounted on vibration isolators. Compressor motors shall be single-phase PSC with overload protection. The finned tube coil shall be sized for low-face velocity and constructed of lanced aluminum fins bonded to rifled copper tubes in a staggered pattern not less than three rows deep.

The coaxial water-to-refrigerant or refrigerant-to-water heat exchanger shall be designed for low water pressure drop and constructed of a convoluted copper (optional cupronickel, source side only) inner tube and a steel outer tube. The thermal expansion valve shall provide proper superheat over the entire liquid temperature range with minimal "hunting." The valve shall operate bi-directionally without the use of check valves.

The water-to-refrigerant heat exchanger and refrigerant suction lines shall be insulated to prevent condensation at low liquid temperatures.

Fan Motor & Assembly

The fan shall be a direct drive centrifugal type with a dynamically balanced wheel. The housing and wheel shall be designed for quiet low outlet velocity operation. Tight fan housing geometry shall not be permitted. The fan housing shall be removable from the unit without disconnecting the supply air ductwork for servicing of the fan motor. The fan motor shall be a variable-speed ECM2 type. The ECM2 fan motor shall be soft starting, shall maintain constant CFM over its operating static range, and shall provide 12 CFM settings. The fan motor shall be isolated from the housing by rubber grommets. The motor shall be permanently lubricated and have thermal overload protection. ECM2 motors shall be long-life ball bearing type.

Electrical

A microprocessor-based controller that interfaces with a multistage electronic thermostat to monitor and control forced air unit operation shall be provided. The controller shall also be capable of operating the unit in a hydronic heating mode with input from an external thermostat. The control shall provide: operational sequencing, fan speed control, high and low pressure switch monitoring, freeze protection, fan failure condensate overflow sensing, auxiliary heat staging, lockout mode control, hot water and loop pump control, LED status and fault indicators, fault memory, field selectable options and accessory output. A detachable terminal block with wiring. All units shall have knockouts for entrance of low and line voltage wiring. The fan motor and control box shall be harness plug wired for easy removal.

Piping

Supply and return water connections (and hot water connections) shall be 1-inch FPT brass swivel fittings which provide a union and eliminate the need for pipe wrenches and sealants when making field connections. All source water piping shall be insulated to prevent condensation at low liquid temperatures on the vertical units. The condensate connection shall be a 3/4-inch PVC socket with internally-trapped hose that can be routed to front or side locations.

Engineering Guide Specifications (cont.)

Accessories and Other Options

Thermostat (Field Installed)

A multi-stage auto-changeover electronic thermostat shall be provided. An OFF-HEAT-AUTO-COOL-EMERG system switch, OFF-AUTO fan switch, and indicating LEDs shall be provided. The thermostat shall read out in °F or °C.

Electrostatic Filter (Field Installed)

A permanent, cleanable 90% efficient electrostatic filter shall be provided in lieu of the standard throwaway type.

Earth Loop Flow Center (Field Installed)

A self-contained module shall provide all liquid flow, fill and connection requirements for ground source closed loop systems up to 20 GPM. The pumps shall be wired to a power block located in the nearest unit. The units shall contain low voltage pump slaving control so that two units

may share one flow center.

Auxiliary Heater (Field Installed)

An electric resistance heater shall provide supplemental and/or emergency heating capability. Vertical units shall have the control box and resistance heater coil assembly mounted internally. A low voltage plug shall be provided in each unit for quick auxiliary heat connection. The heater shall operate in sequenced stages as controlled by the unit's microprocessor. The heater shall feed line voltage power to the unit fan and transformer to provide emergency heat capability in the event of an open compressor circuit breaker.



WaterFurnace®

Smarter from the Ground Up™

WaterFurnace International, Inc.
9000 Conservation Way
Fort Wayne, IN 46809
www.waterfurnace.com

WFI has a policy of continuous product research and development and reserves the right to change design and specifications without notice.
Synergy3 is licensed under U.S. patent No 4,856,578.
©2006 WFI

Product:	Synergy3
Type:	Geothermal Heat Pumps with Water Heating for Radiant Floor Applications
Size:	4 thru 6 Ton
Document Type:	Specification Catalog
Part Number:	SP1554
Release Date:	06/06
Supercedes:	SP1554 (07/05)