

Installer's Guide

1" - 2" Filter Rack Kit

Model:	Used With:
BAYFLTR101C	2/4YC*,WC*,TC*,DC**018-036A
BAYFLTR201C	2/4YC*,WC*,TC*,DC**042-060A

⚠ WARNING: HAZARDOUS VOLTAGE - DISCONNECT POWER BEFORE SERVICING

ALL phases of this installation must comply with NATIONAL, STATE AND LOCAL CODES

IMPORTANT—This Document is **customer property** and is to remain with this unit. Please return to service information pack upon completion of work.

NOTE: This filter rack is required when installing an economizer or any outside air damper and recommends the use of the BAYACCDOR Filter Access Door.

NOTE: To change filter rack from 1" to 2" filters:

- Remove 2 screws that secure the 1" filter angle to the Upper Filter Channel and discard angle.
- Remove 2 screws that secure the 1" filter angle to the Lower Filter Channel and discard angle.

Filter Rack Installation

1. Open or remove the Filter Access Door. See Figure 1.
2. UPPER FILTER CHANNEL:
 - a. Remove the screw from the top of the right coil blank-off plate just inside the Coil Access opening, see Figure 1.
 - b. Hook the left side of the upper filter bracket into the tab projecting from the rear/left end of the indoor coil flashing.
 - c. Install the right side of the upper filter bracket, aligning the slots of the filter frame to the right coil tube sheet engagement holes (where the screw was removed in Step a). See Figure 3.
3. LOWER FILTER CHANNEL:

Slide the lower filter channel across the drain pan and place the channel bracket lip over the drain pan.
4. Install the appropriate filter(s) and fill plate. Close the Filter Access Door or panel. See Table 1 for appropriate filter sizes.

NOTE: For unit horizontal applications, Return Air Panel is to remain attached to the unit base pan return opening. Bottom filter rack channel will sit on top of Return Air Panel perimeter flange.

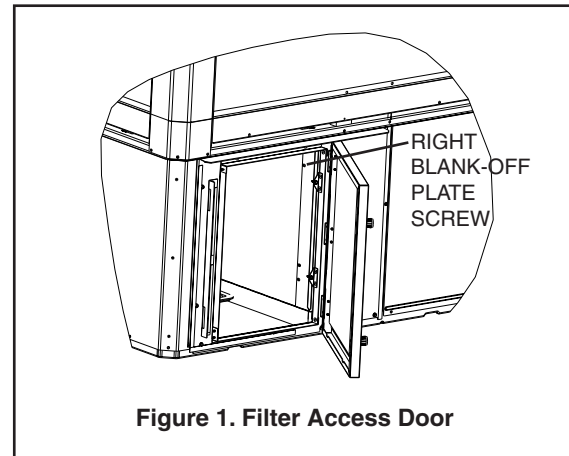

Figure 1. Filter Access Door

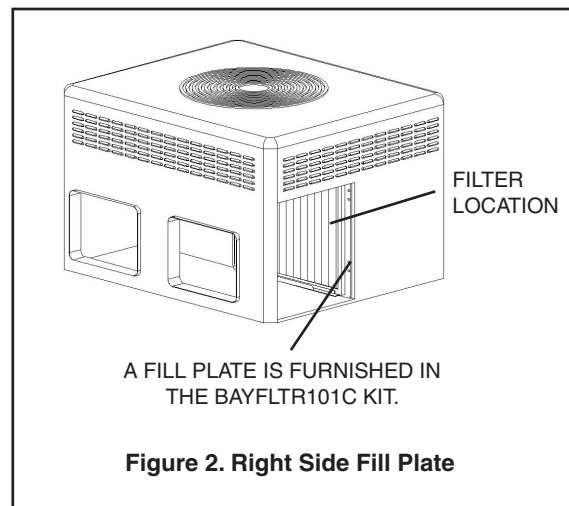

Figure 2. Right Side Fill Plate

⚠ WARNING

HAZARDOUS PRESSURES!

Coils contain refrigerant under pressure. When attaching filter channel assemblies and filter retainer angle to coil blank-off plate use **ONLY** the holes from which you removed the screws. Failure to follow these safety precautions could result in coil bursting, which could result in death or serious injury.

⚠ CAUTION

SHARP EDGE HAZARD!

Be careful of sharp edges on equipment or any cuts made on sheetmetal while installing or servicing. Personal injury may result.

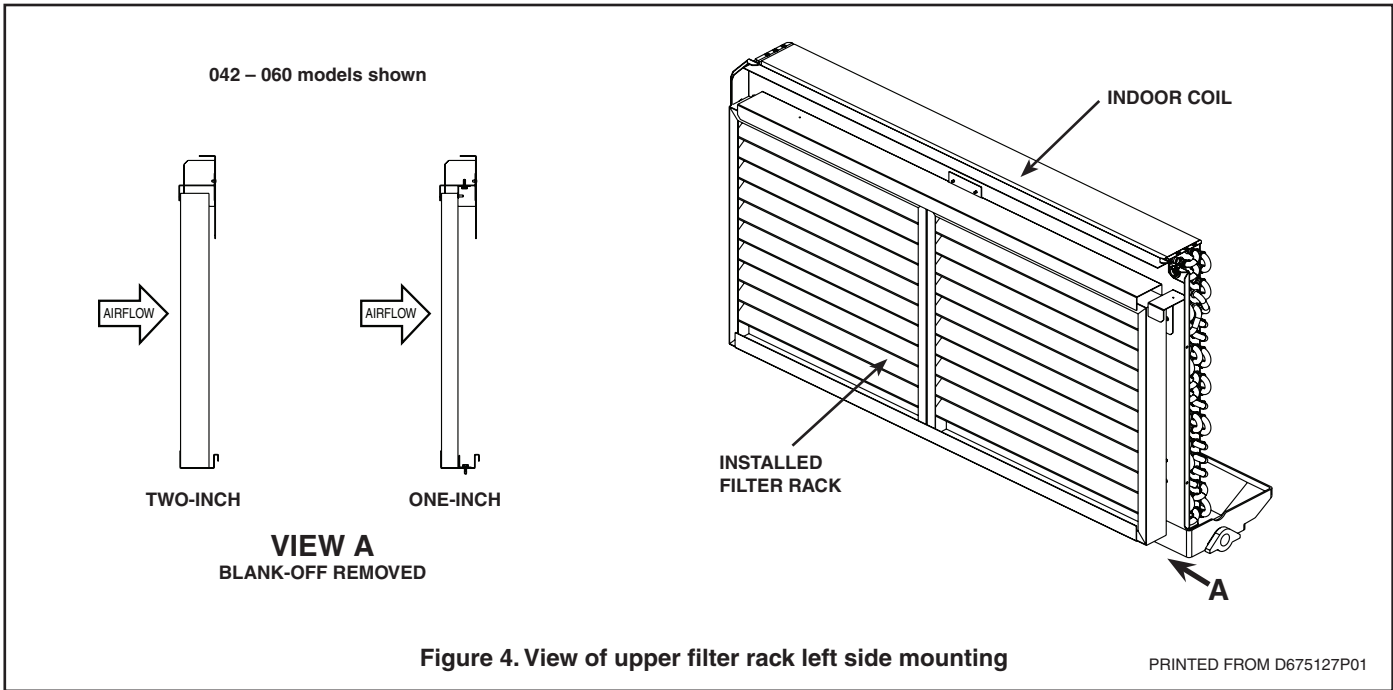
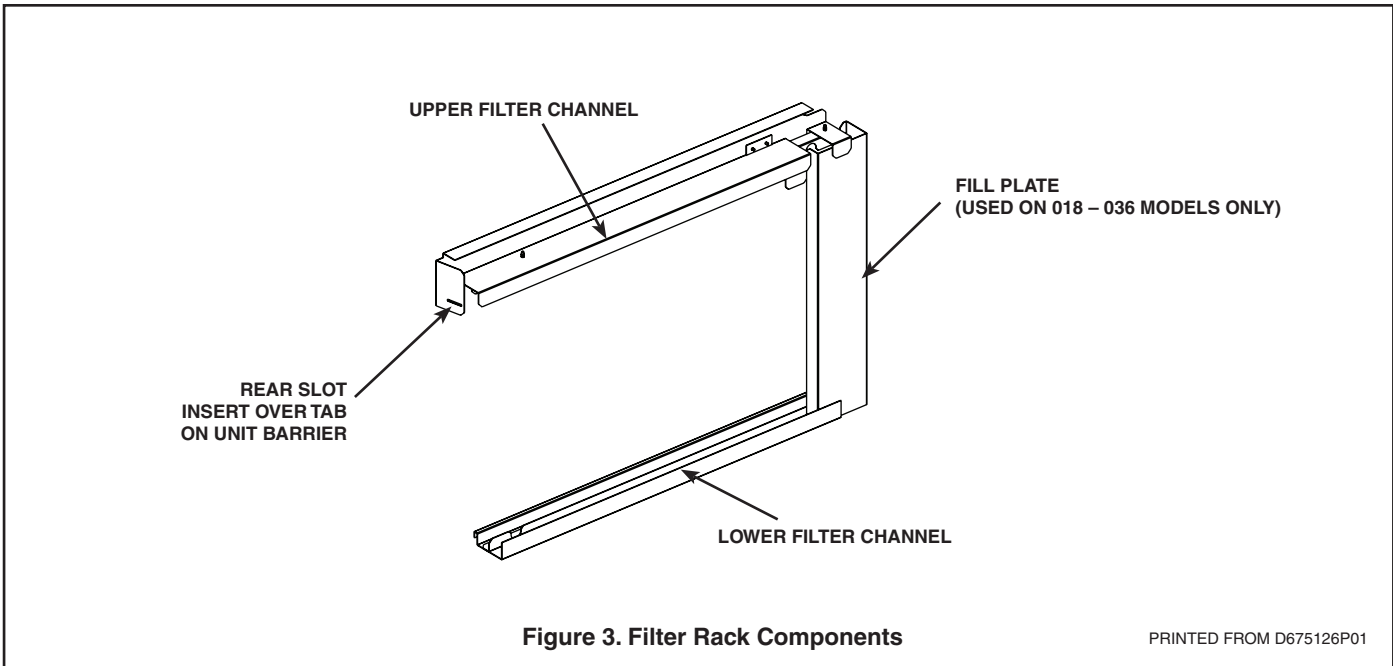

TABLE 1 – Filter Rack Filter Sizes	
Unit Size	Filter Size
018 – 036 Models	Use one 18" x 25" filter (one or two inch)
042 – 060 Models	Use two 18" x 20" filters (one or two inch)*

* Note: If not using BAYACCDOR Filter Access Door, use one 18" x 20" filter and one 18" x 18" filter. (One or two inch)