



Made in USA

ICM 450

Programmable Three Phase Voltage Monitor with 25-Fault Memory

Protects motors from premature failure and burnouts



Installation, Operation & Application Guide

For more information on our complete range of American-made products – plus wiring diagrams, troubleshooting tips and more, visit us at www.icmcontrols.com



Specification

Input

- **Line Voltage:** Universal, 190-630 VAC
- **Frequency:** 50-60 Hz
- **Load Side Monitoring:** Optional
- **Control Voltage:** 18-240 VAC
- **Frequency:** 50-60 Hz

Output

- **Type:** Relay, SPDT
- **Voltage Range:** 240VAC @ 10A maximum
- **Frequency:** 50-60 Hz

Control Operating Temperature

- **Operating Temperature:** -40°F to +167°F (-40°C to +75°C)
- **Storage Temperature:** -40°F to +185°F (-40°C to +80°C)

LCD Operating Temperature

- **Operating Temperature:** -4°F to +167°F (-20°C to +75°C)

Mechanical

- **Mounting:** Surface mount using (2) #8 screws
- **Terminations:** Screw terminals
- **Weight:** 12 ounces (341 grams)

Dimensions

- 6 1/2" L, 4 1/4" W, 1 3/8" H (16.5 cm. L, 10.8 cm. W, 3.5 cm. H)

Parameters

Phase Unbalance Protection

- **Voltage Unbalance:** 2-20% adjustable

Over/Under Voltage Protection

- **Under Voltage:** 2-25% adjustable
- **Over Voltage:** 2-25% adjustable

Phase Loss Protection

- **Phase Loss Condition:** Equals 25% of nominal for any given phase; system will shut down and a fault will be recorded should this occur

Delay on Break Timer

- **Control Voltage:** 18-240 VAC
- **Time Delay:** 0 to 10 minutes adjustable

Fault Interrogation Delay

- **Time Delay:** 0 to 15 seconds adjustable
- Provides a delay between fault detection and system shutdown - helps to eliminate nuisance trips or unnecessary shutdowns

Caution

Installation of the ICM450 shall be performed by trained technicians only. Adhere to all local and national electric codes.

Disconnect all power to the system before making any connections.

Installation

1. Using (2) #8 screws, mount the ICM450 in a cool, dry, easily accessible location in the control panel.
2. Connect voltage as shown in Figure 1 (below). Leave existing line and load side connections intact on the contactor.
3. Load side monitoring is optional (unit may be used to monitor line side only). Wire the contactor and optional control voltage monitoring as in Figures 2 and 3 (below).
 - ** **Note:** Load/line wire must be rated for 3-phase voltage rating, 20ga minimum.
4. Upon application of power, the ICM450 will be on line and will begin to monitor the system.

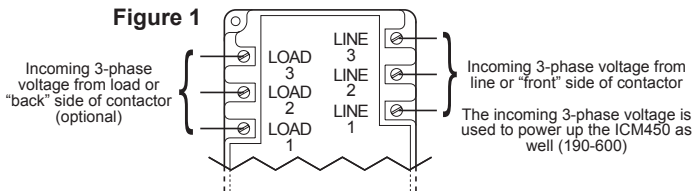

- Terminals 1 and 3 are the control signal input terminals
- "Control Mode" is turned ON or OFF in setup
- With "Control Mode" set to "ON," there must be a voltage present on terminals 1 and 3 for the relay output terminals 4 and 6 to close; this voltage can be supplied from a thermostat, pressure switch, etc.
- When the voltage on these terminals is re-applied, the unit will not re-energize until the delay on break (0-10 minutes) time has elapsed
- Use of terminals 1 and 3 is optional; they will be ignored if the "Control Mode" is set to "OFF"

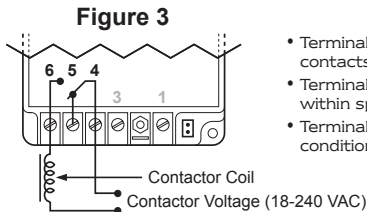
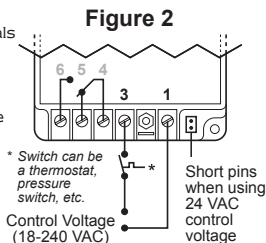

- Terminals 4 and 6 are "dry," normally open contacts
- Terminals 4 and 6 are closed when power is within specifications
- Terminals 4 and 6 open when there is a fault condition or loss of control signal

ICM450 Wiring Diagrams

2-Pole Contactor

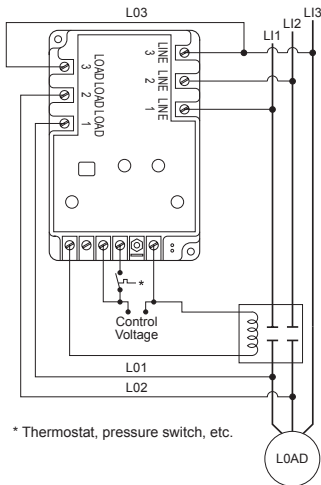

* Thermostat, pressure switch, etc.

3-Pole Contactor

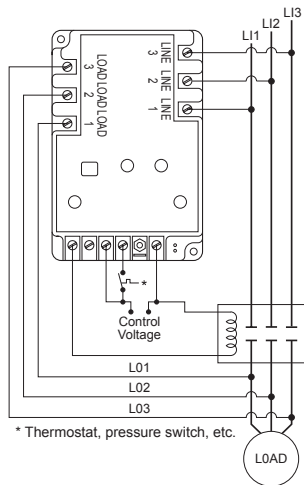

* Thermostat, pressure switch, etc.

Setting the Parameters

1. Press the green SETUP button to enter Setup mode. Setup LED will light.
2. Use the ∇ and \blacktriangle arrows to change user parameters.
3. Scroll through setup by pressing and releasing the SETUP button.
4. When the last parameter has been set, the phase average will be displayed and the Setup LED will automatically turn OFF.

Button Functions



Press arrows to scroll through and select user parameter settings in Setup mode. HOLD down for fast edit.



Press to enter Setup mode and select user parameters.



Hold for voltage display
 $a \rightarrow b$, $b \rightarrow c$, $a \rightarrow c$
 (simultaneously).



Press to read faults. Hold for 5 seconds to clear faults and reset memory.

Parameters

Parameter	Description	Range	Default	Recommended
Line Voltage	Average phase to phase line voltage	190-600	208	Nameplate Voltage
Delay On Break	Amount of time between the load de-energizing and re-energizing	0-10 minutes	.1 minute	4 minutes**
Fault Interrogation	Amount of time before the load de-energizes due to a non-critical fault*	0-15 seconds	15 seconds	7-8 seconds**
% Over/Under Voltage	Maximum/minimum phase to phase average voltage, respectively	2-25%	20%	12-15%**
% Phase Unbalance	Amount of allowable voltage unbalance	2-20%	20%	4-5%**
Reset Mode	AUTO or number of times the load can be re-energized after a load side fault before a manual reset is necessary ** Note: When monitoring line side only, the reset mode will always be AUTO	AUTO, 0-10	AUTO	AUTO
Control Mode	With control mode set to OFF, the load will energize if no 3- phase fault conditions exist; with control mode ON, the load will energize if no fault conditions exist and control voltage is present at terminals 1 and 3 of the ICM450	ON or OFF	ON	Based on wiring

* Non-critical faults are faults such as High/Low Voltage and Phase Unbalance. Critical faults, such as Phase Loss and Phase Reversal, have a fault interrogation of under 2 seconds and it is not user adjustable.

** For best recommendations, consult manufacturer of equipment.

Fault Conditions

Press and release fault button to scroll through all saved faults.

**** Note:** For initial setup, press and hold FAULT for 5 seconds to remove any previously stored faults.

Fault	Problem	Corrective Action
Back Phase Loss	Not all three of the phases on the load side are present	<ol style="list-style-type: none"> 1. Re-energize the contactor. 2. If the fault reappears after the load energizes: <ol style="list-style-type: none"> a. Turn all power OFF b. Check all load side connections c. Check the contacts of the contactor for debris or excess carbon.
Back Phase Rev	Loads 1, 2, or 3 are not in sequence (not 120° phase shifted)	<ol style="list-style-type: none"> 1. Turn OFF all power. 2. Swap any 2 phases on the load side of the ICM450 only (example: swap load 1 and load 2) * 3. Re-apply power.
Back Phase Unbal	A voltage unbalance between the three load phases exceeds the unbalance setpoint	<ol style="list-style-type: none"> 1. Press the READ button to observe the present load voltages. Check system for unbalance cause. 2. Increase the fault interrogation time if necessary. 3. Increase the percent unbalance setting if necessary.
Front Over Volt	Average phase-phase voltage exceeds the maximum percentage	<ol style="list-style-type: none"> 1. Check system for over-voltage cause. 2. Increase the percent over-voltage setting if necessary. 3. Increase the fault interrogation time if necessary.
Front Phase Loss	Not all three of the phases on the line side are present	<ol style="list-style-type: none"> 1. Press and hold the READ button on the phase monitor or use an AC voltmeter to carefully measure all three phase-phase line voltages (example: Line 1 → Line 2, Line 2 → Line 3, Line 3 → Line 1). 2. Repair the missing phase.
Front Phase Rev	Lines 1, 2, or 3 are not in sequence (not 120° phase shifted)	<ol style="list-style-type: none"> 1. Turn OFF all power. 2. Swap any 2 phases on the line side of the ICM450 (example: swap load 1 and load 2)* 3. Re-apply power.
Front Phase Unbal	A voltage unbalance between the three line phases exceeds the unbalance setpoint	<ol style="list-style-type: none"> 1. Press the READ button to observe the present load voltages. Check system for unbalance cause. 2. Increase the fault interrogation time if necessary. 3. Increase the percent unbalance setting if necessary.
Front Under Volt	Average phase-phase voltage is below the minimum percentage	<ol style="list-style-type: none"> 1. Check system for under-voltage cause. 2. Increase the percent under-voltage setting if necessary. 3. Increase the fault interrogation time if necessary.

* **Only** swap phases during initial setup, **not** after the ICM450 has been in operation without errors.

Troubleshooting

Problem	LCD Readout	LED Status	Corrective Action
Load will not energize	Phase Avg.	All LEDs Off	Confirm that the control input (terminals 1 & 3) is properly connected and configured (see Pages 1 and 3)
Load will not energize	Phase Avg.	Load LED Off, Fault LED blinking	Press FAULT to observe the current fault; correct the condition of the first fault that appears (see Fault Conditions, Page 4 for a list of corrective actions)
Fault LED blinks repeatedly while load is energized	Phase Avg.	Fault LED Blinking, Load LED On	Indicates there are faults saved in the memory, press FAULT rapidly to scroll through saved faults; to clear the faults, press and hold FAULT for more than 5 seconds
Load will not de-energize when control voltage is OFF	Phase Avg.	Load LED On, Control LED Off	The control mode setting is OFF; press SETUP to get to the control mode. Press ^ to set the control mode ON
Setup LED is on while load is being energized	Anything Other Than Phase Avg.	Setup LED On, Load LED On	To exit the setup mode, press either READ or FAULT
Load will not energize	Reset	Fault LED Blinking	Unit in lockout; maximum number of retries in manual reset mode has been reached; to reset unit, press FAULT and hold for more than 5 seconds
Load turns ON and OFF repeatedly	Readout is Irrelevant	Fault LED Blinking	Fix load side fault; press FAULT to observe condition; the delay on break period may be too short; press SETUP to enter the delay on break mode; press ^ to lengthen the delay

ONE-YEAR LIMITED WARRANTY

The Seller warrants its products against defects in material or workmanship for a period of one (1) year from the date of manufacture. The liability of the Seller is limited, at its option, to repair, replace or issue a non-case credit for the purchase prices of the goods which are provided to be defective. The warranty and remedies set forth herein do not apply to any goods or parts thereof which have been subjected to misuse including any use or application in violation of the Seller's instructions, neglect, tampering, improper storage, incorrect installation or servicing not performed by the Seller. In order to permit the Seller to properly administer the warranty, the Buyer shall: 1) Notify the Seller promptly of any claim, submitting date code information or any other pertinent data as requested by the Seller. 2) Permit the Seller to inspect and test the product claimed to be defective. Items claimed to be defective and are determined by Seller to be non-defective are subject to a \$30.00 per hour inspection fee. This warranty constitutes the Seller's sole liability hereunder and is in lieu of any other warranty expressed, implied or statutory. Unless otherwise stated in writing, Seller makes no warranty that the goods depicted or described herein are fit for any particular purpose.



7313 William Barry Blvd., North Syracuse, NY 13212
(Toll Free) 800-365-5525 (Phone) 315-233-5266 (Fax) 315-233-5276

www.icmcontrols.com

LIA164-4