

ICM450 THREE-PHASE VOLTAGE MONITOR



Stop Motor Burnouts!

Programmable 3-phase line voltage monitor with 25-fault memory, high temperature LCD display, easy setup & clear, diagnostic readout of system faults, 190 to 630 VAC operation...

The ICM450 was specifically designed to protect motors and other 3-phase loads from premature failure and damage due to common voltage faults such as voltage unbalance, over/under voltage, phase loss, reversal, incorrect sequencing and rapid short cycling.



Mode of Operation

At power up, the **ICM450** evaluates the incoming power for proper phase sequence, amplitude, and symmetry (voltage unbalance). If the three phase input at the line side connections is within user-set parameters, the load energize LED is turned on and the internal relay is energized. Continuity will be across terminals 4 and 6. If connections are made to the load side terminals, the **ICM450** will transfer monitoring over to the load side only.

When a critical fault condition (phase loss or phase reversal) is present, the relay will immediately de-energize, the load-energized LED will turn off, the fault LED will flash, and the fault is written to memory. Continuity will be across terminals 4 and 5.

If a non-critical fault condition (unbalance, high or low voltage) is present, the **ICM450** will ignore it during the interrogation delay time. If it is still present following the interrogation delay time, the relay will de-energize, the load-energized LED will turn off, the fault LED will flash, and the fault is written to memory. Continuity will be across terminals 4 and 5.

The **ICM450** will store the last 25 faults in memory. The relay will not energize if any fault conditions exist. The integral adjustable delay on break timer will prevent short cycling.

Features

- **Reliable, high temperature LCD display**
 - Simplifies system setup and diagnostics. Indicates condition of incoming line voltage, fault conditions, system setpoints and other user adjustments.
 - Temperature: -20°C to +75°C (-4°F to + 167°F)
- **Simultaneous voltage display (an ICM exclusive)**
 - View all 3 phases, no need to scroll through readouts.
- **Fully adjustable variables**
 - User may easily set and adjust variables in **SETUP** mode:
 - Line voltage: 190 to 600 VAC
 - Voltage unbalance: 2 to 20%
 - Delay on break period: 0 to 10 minutes
 - Fault interrogation: 0 to 15 seconds
 - Over/under voltage: 2 to 25%
 - Reset modes: AUTO or 0 to 10 retries
 - Control mode: ON or OFF
- **25-fault memory and storage**
 - Clearly displayed on LCD
- **Ultra bright LED indicators**
 - Shows current mode:
 - Setup LED
 - Load energized LED
 - Control voltage LED
 - Fault LED
- **Easy to install and configure**
 - Simple 7-step push-button setup
 - Wiring diagram on unit
 - Installation and application guide included

Wiring Diagram

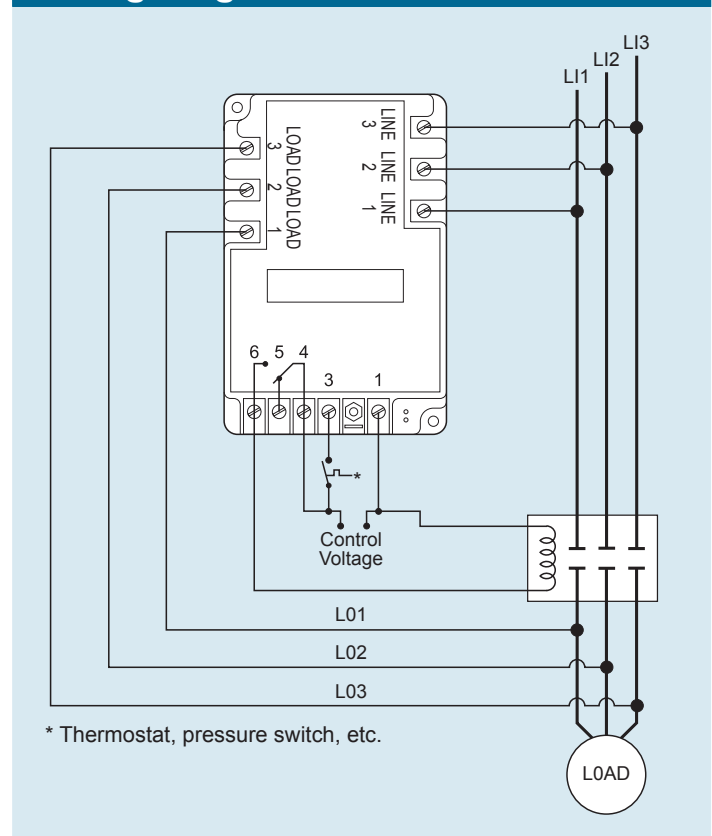

Specifications

Input

- **Line Voltage:** Universal (190-630 VAC)
- **Frequency:** 50/60 Hz

Output

- **Type:** Relay
- **Form:** SPDT
- **Voltage Range:** Up to 240 VAC (maximum: 10 amps)
- **Frequency:** 50/60 Hz

Control Operating Temperature

- **Operating Temperature:** -40°C to +75°C
(-40°F to +167°F)
- **Storage Temperature:** -40°C to +85°C
(-40°F to +185°F)

LCD Operating Temperature

- **Operating Temperature:** -20°C to +75°C
(-4°F to +167°F)

Phase Unbalance Protection

- **Voltage Unbalance:** 2-25% adjustable

Over/Under Protection

- **Under Voltage:** 2-25% adjustable
- **Over Voltage:** 2-25% adjustable

Phase Loss Protection

- Phase Loss condition = <25% of nominal for any given phase. System will shut down and a fault will be recorded should this condition occur

Delay on Break Timer

- **Control Voltage:** 18-240 VAC
- **Time Delay:** 0-10 minutes adjustable

Fault Interrogation Delay

- **Time Delay:** 0-15 seconds adjustable
- Provides a delay between fault detection and system shutdown, eliminating nuisance trips/unnecessary shutdowns.

Mechanical

- **Mounting:** Surface mount using (2) #8 screws
- **Termination:** Screw terminals
- **Weight:** 12 ounces (341 grams)
- **Dimensions:** 6.5" x 4.25" x 1.4" (16.5 x 10.8 x 3.5 cm)

Installation and Setup

- Application Guide included with unit

System Diagram

