

External control set

INSTALLATION MANUAL

For authorized service personnel only.

Contents

1. SAFETY PRECAUTIONS.....	1
2. ABOUT THE UNIT	
2.1. Accessories.....	2
3. SETTING	
3.1. Setting (TYPE A).....	2
3.2. Setting (TYPE B).....	3
4. CONNECTING TO EXTERNAL DEVICE.....	4

1. SAFETY PRECAUTIONS

⚠ WARNING

This mark indicates procedures which, if improperly performed, might lead to the death or serious injury of the user.

- When installing each wire, please thoroughly read this manual.
- Before installation be sure that all sources of power have been shut off. There is a danger of electric shock.
- Use the voltage as described in the signal specifications. Using voltage of other specifications may result in malfunction and erroneous operation of the air conditioner.

⚠ CAUTION

This mark indicates procedures which, if improperly performed, might possibly result in personal harm to the user, or damage to property.

- When connecting the wires, install the insulating tube or other insulator on the connection.
- Do not pull on the connectors with too much force.

2. ABOUT THE UNIT

• SETTING depends on the PCB TYPE of the indoor unit. Check the PCB TYPE in the table below and set it up.

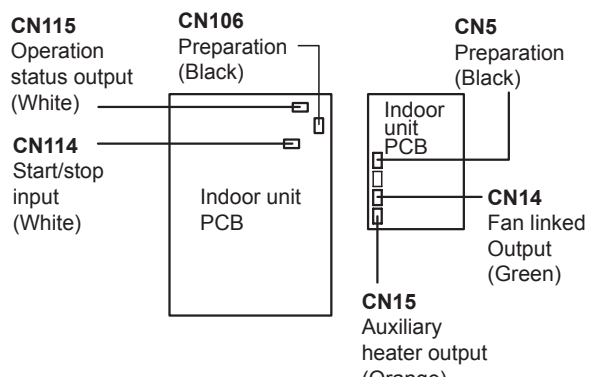
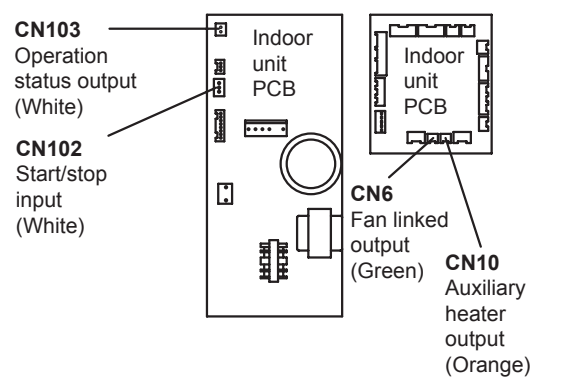
	TYPE A	TYPE B
PCB LAYOUT		
	<p>↓</p> <p>SEE 3.1.Setting (TYPE A)</p>	<p>↓</p> <p>SEE 3.2.Setting (TYPE B)</p>

2.1. Accessories

- The following installation parts are supplied. Use them as required.

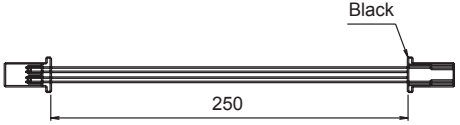
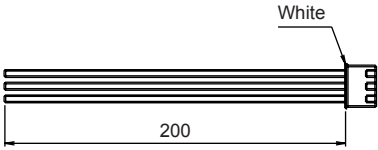
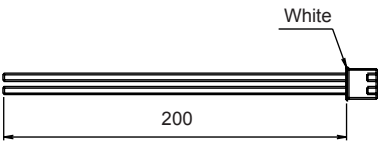
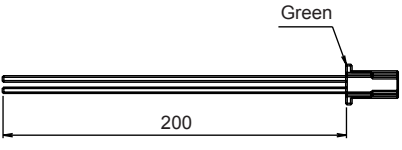
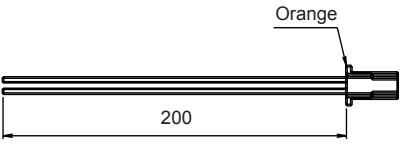
Name and shape	Q'ty	Description	Connector	
			TYPE A	TYPE B
Installation manual 	1	This manual		
Wire (Preparation) 	1	Preparation When the external input/output is used, connect the external signal wire.	CN106 CN5	Not used
Wire (Start/stop input)  WIRE TYPE : AWG22 UL1430	1	Start/stop input You can control air conditioner on/off by external input.	CN114	CN102
Wire (Operation status output)  WIRE TYPE : AWG22 UL1430	1	Operation status output You can display air conditioner on/off by external output.	CN115	CN103
Wire (Fan linked output)  WIRE TYPE : AWG24 UL1430	1	Fan linked output You can control sub fan by synchronization with fan operation of indoor unit.	CN14	CN6
Wire (Auxiliary heater output)  WIRE TYPE : AWG24 UL1430	1	Auxiliary heater output You can control electrical heater (booster) by synchronization with heating operation. Only Duct type air conditioner.	CN15	CN10

3. SETTING

3.1. Setting (TYPE A)

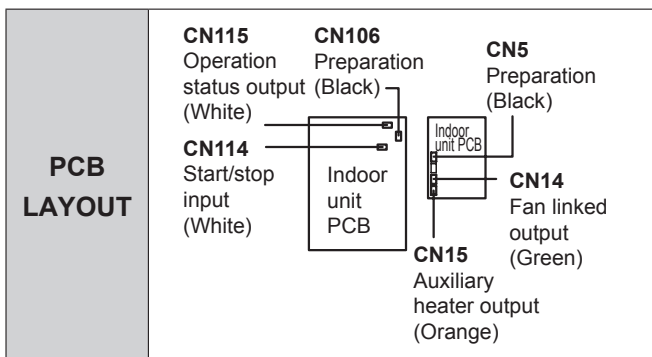

3.1.1. Preparation

- When the external input/output is used, connect the external signal wire as shown in the figure.

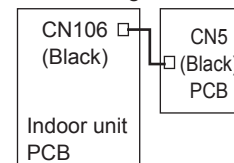

3.1.2. Start/stop input setting

- You can control air conditioner ON/OFF operation by external input.
- You can select either Edge and Pulse by changing the DIP-switch on the indoor unit.

	NO.	SW state	
		OFF	ON
SW2 DIP-Switch	2	Edge	Pulse

SIGNAL SPECIFICATION

- No voltage
- ON/OFF continuous signal
- Contact capacity : DC12V 10mA

Edge signal

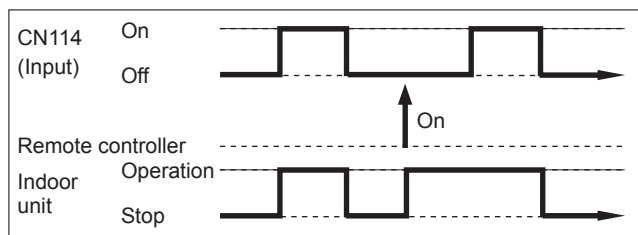

Pulse signal

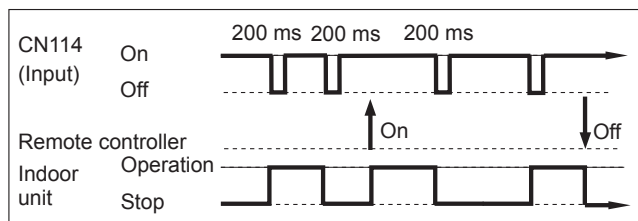

Setting example

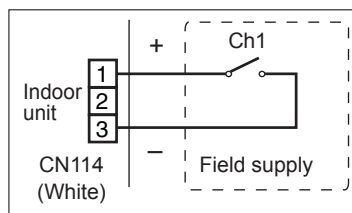

Connection of No.2 wire is not required.

3.1.3. Operation status setting

- You can display air conditioner ON/OFF operation by external output.

SIGNAL SPECIFICATION

- No voltage contact.
- Contact capacity : Max. DC24V 10mA to 1A or less

Output signal

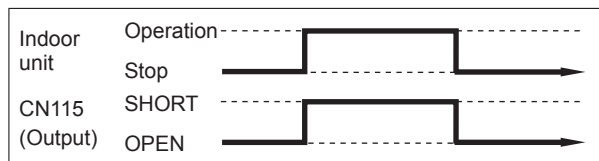

Setting example

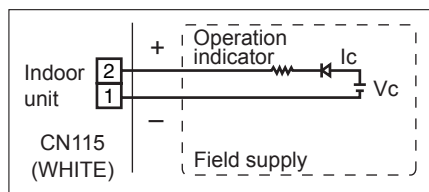

3.1.4. Fan linked output setting

- You can control sub fan by synchronization with fan operation of indoor unit.

Output signal

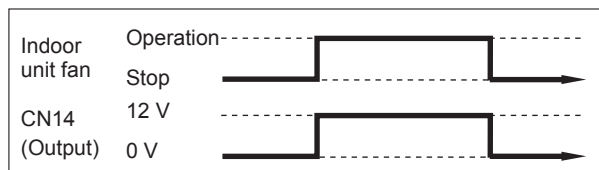

Setting example

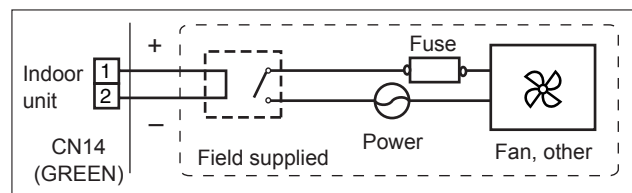

3.1.5. Auxiliary heater output setting (Only duct type air conditioner)

- You can control electrical heater (booster) by synchronization with heating operation.
- When temperature is -10 to -3 degrees from set point, external electrical heater is ON.
- When temperature is -1 degree from set point, external electrical heater stops.

JUMPER WIRE (INDOOR UNIT)

- This is used to continue indoor unit fan operation for 1 minute after thermo OFF in heating mode.
- 1 minute delay control set by cutting JM3 on PCB.

Output signal

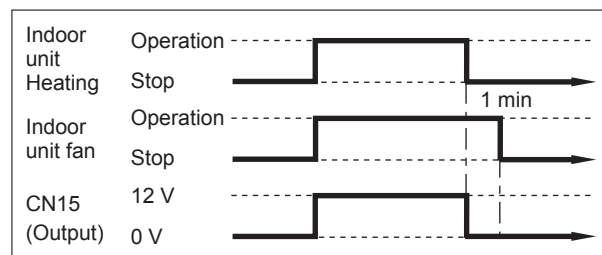

Setting example

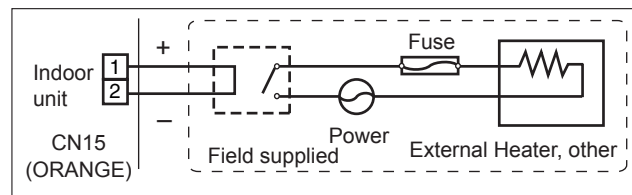

CAUTION

Please locate external a heater between the indoor unit and the ductwork.
Please be sure to use delay control of a fan.

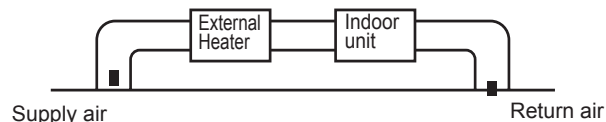

3.2. Setting (TYPE B)

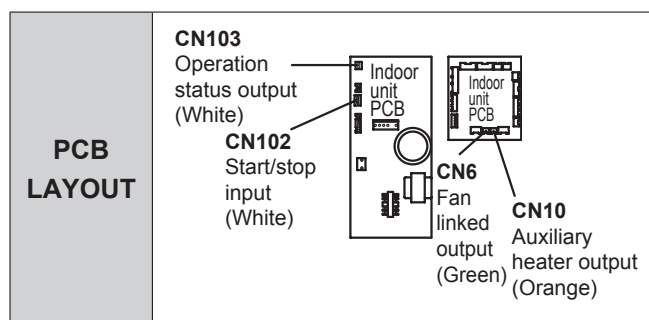

3.2.1. Start/stop input setting

- You can control air conditioner ON/OFF operation by external input.

SIGNAL SPECIFICATION

- No voltage
- ON/OFF continuous signal
- Contact capacity : DC12V 10mA

Input signal

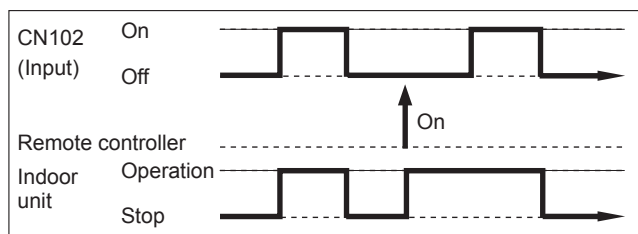

Setting example

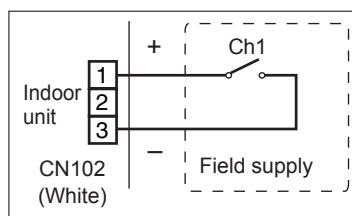

Connection of No.2 wire is not required.

3.2.2. Operation status setting

- You can display air conditioner ON/OFF operation by external output.

SIGNAL SPECIFICATION

- No voltage contact.
- Contact capacity : Max. DC24V 10mA to 1A or less

Output signal

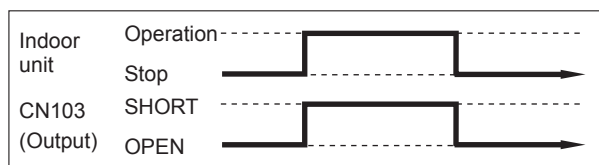

Setting example

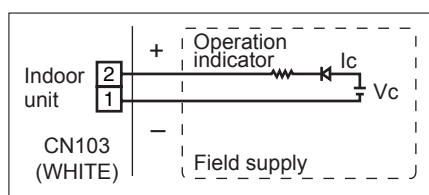

3.2.3. Fan linked output setting

- You can control sub fan by synchronization with fan operation of indoor unit.

Output signal

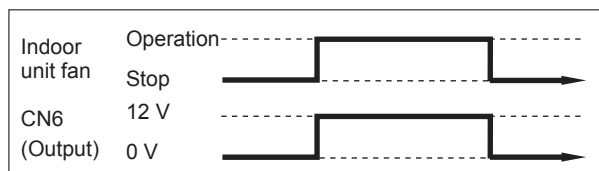

Setting example

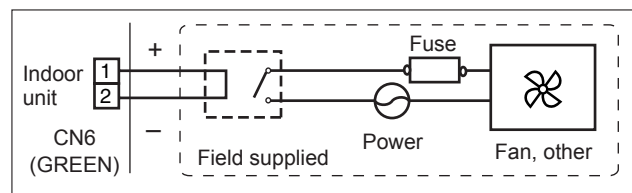

3.2.4. Auxiliary heater output setting (Only duct type air conditioner)

- You can control electrical heater (booster) by synchronization with heating operation.
- When temperature is -10 to -3 degrees from set point, external electrical heater is ON.
- When temperature is -1 degree from set point, external electrical heater stops.

JUMPER WIRE (INDOOR UNIT)

- This is used to continue indoor unit fan operation for 1 minute after thermo OFF in heating mode.
- 1 minute delay control set by cutting JM3 on PCB.

Output signal

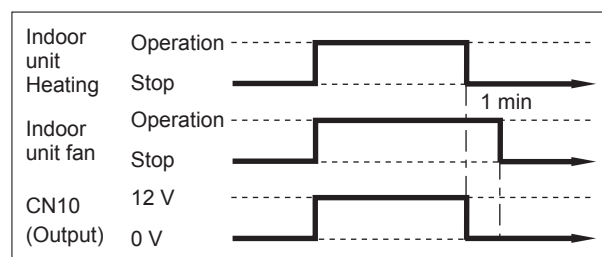

Setting example

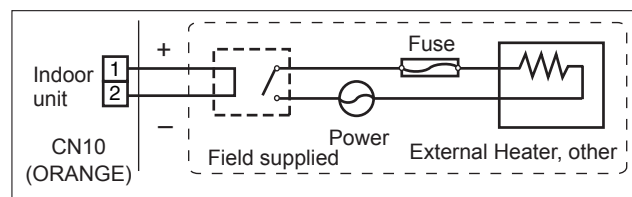

CAUTION

Please locate external a heater between the indoor unit and the ductwork.
Please be sure to use delay control of a fan.

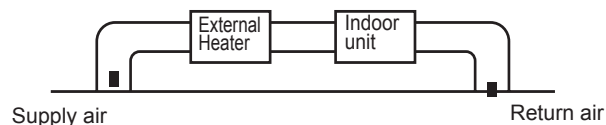

4. CONNECTING TO EXTERNAL DEVICE

- Connect the tip of the wire to the external equipment.
- If necessary, extend it with locally procured wire.
- Ensure that the connecting part is insulated for protection.

