



**Brass Ball Valve  
Two-Piece, Full Port  
Press X Hose Ends**

**BA-480BH\* 1/2" - 3/4" 200 PSIG @ 250° F  
Blow-Out Proof Stem**

MATERIALS LIST			
ITEM	PART	MATERIAL	ASTM/SPEC
1	Body	Brass, Forged	B283
2	Tailpiece	Brass, Forged	B283
3	Ball	CP Brass Ball	B283
4	Ball Seat	PTFE	Commercial
5	Stem	Brass	B124
6	Stem O-Ring	Buna-N	D2000
7	Thrust Washer	PTFE	Commercial
8	Gland Nut	Brass	B124
9	Packing	PTFE	Commercial
10	Handle	Zinc Plated Steel	B633
11	Handle Nut	Zinc Plated Steel	B633
12	Tube O-Ring	EPDM	D2000 NSF61
13	Hose Cap	Polypropylene	
14	Cap Gasket	EPDM	
15	Chain	Brass Bead	

Rev. 3

\*Ultra Press Valves are designed and qualified for use in copper tubing systems only, Types K, L, & M per ASTM B88.

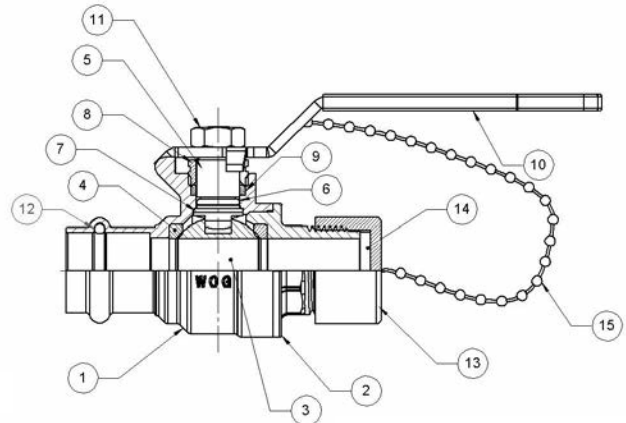

Do not pressurize cap.

Dimensions			
Size		1/2" DN15	3/4" DN20
A	inch	0.51	0.76
	mm	13	19
B	inch	3.06	3.5
	mm	78	90
C	inch	1.41	1.66
	mm	36	42
D	inch	1.46	1.93
	mm	37	49
E	inch	3.14	4.35
	mm	80	110
F	inch	0.63	0.88
	mm	15	20
Cv		18	40
TOURQUE	in. lb	19	58
	N.m	21	6.5
WEIGHT	lbs.	.51	.95
	grams	231	431.81

**NOTE:** Pressure / Temperature ratings shown are for valve only. Hose side pressure and temperature limit is based on connected hose and is the users responsibility.



The information presented on this sheet is correct at the time of publication. Milwaukee Valve reserves the right to change design, and/or material specifications without notice. For the Installation, Operation and Maintenance Manual (IOM) see the engineering section on our website. For the most current information access [www.milwaukeevalve.com](http://www.milwaukeevalve.com)

