

WIRE ROPE SLINGS

GENERAL INFORMATION



Figure 1.

NOMINAL SLING STRENGTH is based upon the nominal (catalog) rope strength of the wire rope used in the sling and other factors which affect the overall strength of the sling. These other factors include splicing efficiency, number of parts of rope in the sling, type of hitch (e.g., straight pull, choker hitch, basket hitch, etc.), diameter around which the body of the sling is bent (D/d) and the diameter of pin used in the eye of the sling (Figure 1).



Figure 2.

SLING ANGLE is the angle measured between a horizontal line and the sling leg or body. This angle is very important and can have a dramatic effect on the rated capacity of the sling. As illustrated (Figure 2), when this angle decreases, the load on each leg increases. This principle applies whether one sling is used to pull at an angle, in a basket hitch or for multi-legged bridle slings. Sling angles of less than 30 degrees are not recommended.



Figure 3. Choker hitch rated capacity adjustment. For wire rope slings in choker hitch when angle is less than 135°.

CHOKER HITCH configurations affect the rated capacity of a sling. This is because the sling leg or body is passed around the load, through one end attachment or eye and is suspended by the other end attachment or eye. The contact of the sling body with the end attachment or eye causes a loss of sling strength at this point. If a load is hanging free, the normal choke angle is approximately 135 degrees. When the angle is less than 135 degrees an adjustment in the sling rated capacity must be made (Figure 3).

TABLE 1 CHOKER HITCH RATED CAPACITY ADJUSTMENT	
ANGLE OF CHOKE IN DEGREES	RATED CAPACITY IWRC AND FC ROPE PERCENT**
OVER 120	100
90-120	87
60- 89	74
30- 59	62
0 - 29	49

**Percent of sling rated capacity in a choker hitch.



Figure 4.

As can be seen, the decrease in rated capacity is dramatic. Choker hitches at angles greater than 135 degrees are not recommended since they are unstable. Extreme care should be taken to determine the angle of choke as accurately as possible.

NOMINAL SPLICE EFFICIENCY is the efficiency of the sling splice. Any time wire rope is disturbed such as in splicing an eye, the strength of the rope is reduced. This reduction must be taken into account when determining the nominal sling strength and in calculating the rated capacity. Each type of splice has a different efficiency, thus the difference in rated capacities for different types of slings. Nominal splice efficiencies have been established after many hundreds of tests over years of testing. D/d ratio is the ratio of the diameter around which the sling is bent divided by the body diameter of the sling (Figure 4). This ratio has an effect on the rated capacity of the sling only when the sling is used in a basket hitch. Tests have shown that whenever wire rope is bent around a diameter, the strength of the rope is decreased. Figure 5 illustrates the percentage of decrease to be expected. This D/d ratio is applied to wire rope slings to assure that the strength in the body of the sling is at least equal to the splice efficiency. When D/d ratios smaller than those listed in the rated capacity tables are necessary, the rated capacity of the sling must be decreased.

RATED CAPACITY is the maximum static load a sling is designed to lift. The tables give rated capacities in tons of 2000 pounds. Rated capacities contained in all the tables were calculated by computer. Each value was calculated starting with the nominal component rope strength and working up from there. Due to computer rounding of numeric values, rated capacity values for 2, 3 or 4 leg slings may not be even multiples of single leg values and may differ by a small amount. This represents the state-of-the-art technology and tables found in other publications which differ by this small amount should not be construed to be in error. The difference is generally no more than one unit for any sling diameter.

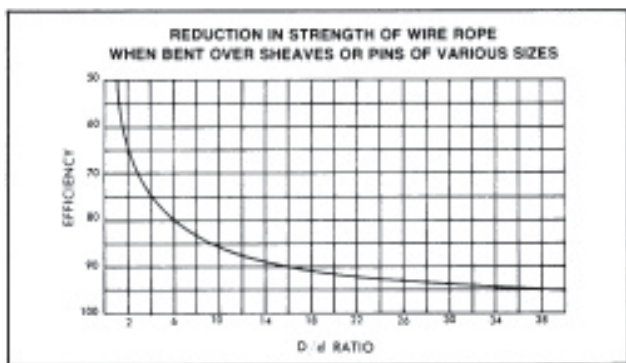

Figure 5. When a wire rope is bent around any sheave or other circular object there is a loss of strength due to this bending action. As the D/d ratio becomes smaller this loss of strength becomes greater and the rope becomes less efficient. This curve, derived from actual test data, relates the efficiency of a rope to different D/d ratios. This curve is based on static loads only and applies to 6x19 and 6x37 class ropes.



Figure 6.

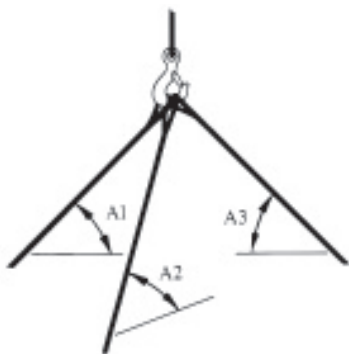

Figure 7. For bridle slings with legs of unequal length, use the smallest horizontal angle for rated capacity calculations.

PROOF LOAD is a specific load applied to a sling or assembly in a non-destructive test to verify the workmanship of the sling. All swaged socket or poured socket assemblies should be proof loaded. The proof load is generally two (2) times the vertical rated capacity for mechanical splice slings. The maximum proof load for hand tucked slings is 1.25 times the vertical rated capacity. Care should be taken to assure that sling eyes are not

damaged during the proof load.

EYE DIMENSIONS are generally eight (8) sling body diameters wide by sixteen (16) body diameters long. Whenever possible thimbles are recommended to protect the rope in the sling eye. Eye dimensions for thimbles are contained in table 2. Table 2 contains only dimensions for thimbles used in standard single part slings. Other specialized thimbles are available. Consult your sling manufacturer for details.

PIN DIAMETER should not be any greater than the natural width of the sling eye. For any sized eye and type of sling body, the maximum allowable pin diameter may be calculated as follows:

$$\text{Maximum pin diameter} = (2L + W) \times 0.2$$

Where

L = length of eye

W = width of eye

The minimum pin diameter should never be smaller than the nominal sling diameter.

GRADE & CONSTRUCTION of wire rope for slings is generally accepted to be bright Improved Plow Steel or Extra Improved Plow Steel grade 6x19 or 6x37 classification regular lay. IWRC rope has a higher rated capacity than Fiber Core rope for mechanically spliced slings, but the same rated capacity for hand tucked slings. This is because when making a hand tucked splice, the core (IWRC) of the rope is cut in the splice area and doesn't add to the overall strength of the sling. Rated capacities of slings using galvanized rope depend on the method of galvanizing. The sling manufacturer should be consulted regarding rated capacities for these types of slings.



MINIMUM SLING BODY LENGTH is the minimum length of wire rope between splices, sleeves or fittings. Generally the minimum body length is equal to ten (10) times the sling body diameter. This allows approximately one and one half (1 1/2) rope lays between splices. For multi-part slings the minimum body length between splices is equal to forty (40) times the component rope diameter.

LENGTH TOLERANCE is generally plus or minus two (2) body diameters, or plus or minus 0.5% of the sling length, whichever is greater. The legs of bridle slings, or matched slings are normally held to within one (1) body diameter. Tolerances on poured or swaged socket assemblies are generally much closer. Tolerances should always be specified to the sling manufacturer before the order is placed. This eliminates a lot of frustration and confusion later.

HAND TUCKED SPLICE

A HAND TUCKED splice is made by passing the wire rope around a thimble or forming an eye and splicing the dead end (short end) into the live end (long end) of the rope. Normally, each dead end strand is given one forming tuck and three full tucks around the same strand in the body of the rope. One additional full tuck is made when splicing more pliable wire ropes such as 6x37 classification.

A “forming tuck” is made by prying two adjacent strands apart, inserting a dead end strand into the opening and passing the strand under one, two, or three adjacent strands in the body of the rope. The dead end strand is set or locked tightly.

A “full tuck” is made by inserting a dead end strand under and rotating it one full 360 degrees turn around a strand in the body of the wire rope. The tucked strand is set or locked tightly. Each subsequent full turn of the dead end strand around the live end strand constitutes an additional full tuck.

“Setting” or “locking” of a dead end strand is accomplished by pulling the strand end in under considerable force. A marlin spike is inserted in the same opening in the body of the rope ahead of the tucked strand and is rotated about the axis of the rope back to the start of the splice or toward the previous tuck. This helps set the tuck.

Certain end usages may indicate the desirability of special splices such as the Navy Admiralty Splice or logging splice. Splices made by these special methods may also attain the efficiencies used in calculating the rated capacity tables where the rope quality and number of tucks are equivalent to that outlined above. Development of such efficiencies should be confirmed by the sling fabricators making such splices.

Serving or wrapping of wire rope sling splices does not affect the splicing efficiencies nor rated capacities. Such servings are optional, although unserved splices are preferred because they permit visual inspection of the spliced area.

NOMINAL SPLICE EFFICIENCIES are measured in terms of efficiency (where efficiency = actual breaking strength of spliced termination divided by actual breaking strength of rope). This efficiency will change from splice to splice because of the many variable factors involved in producing the splice. Splice efficiencies given in table 3 were established so that these normal variations are accommodated. The design factor used in establishing the rated capacities further assures that the sling will lift the load even in those rare instances when the splice efficiency falls slightly below the values given in the tables. Rated capacities shown in this manual have met with the most exacting test, that of the test of time and use in over fifty years of actual field experience.

TABLE 3 NOMINAL SPLICE EFFICIENCIES HAND TUCKED SPLICE IPS AND EIPS IMPROVED PLOW STEEL AND EXTRA IMPROVED PLOW STEEL 6x19 & 6x37 CLASS ROPES			
Rope Dia.	Nominal Eff. Factor	Rope Dia.	Nominal Eff. Factor
1/4	.90	1 1/4	.80
5/16	.89	1 3/8	.80
3/8	.88	1 1/2	.80
7/16	.87	1 5/8	.80
1/2	.86	1 3/4	.80
9/16	.85	1 7/8	.80
5/8	.84	2	.80
3/4	.82	2 1/8	.80
7/8	.80	2 1/4	.80
1	.80	2 3/8	.80
1 1/8	.80	2 1/2	.80

WIRE ROPE SLINGS

2

GENERAL PRECAUTIONS for hand tucked slings are about the same as for any other type of sling. The use of a swivel on single leg lifts as well as free hanging loads which may rotate is not recommended. A tag line should always be used to prevent rotation of the sling body. When the sling body of a hand tucked splice is allowed to rotate, the splice could unlay and pull out, thus causing the load to drop.

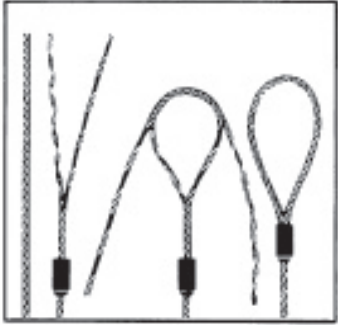

Flemish eye splice.

MECHANICAL SPLICE

MECHANICAL SPLICE slings come in two basic types. One being the Returned Loop and the other the Flemish

Eye or farmers splice. In either case, the splice is completed by pressing (swaging) one or more metal sleeves over the rope juncture.

The returned loop is fabricated by forming a loop at the end of the rope, sliding one or more metal sleeves over the short end of the loop eye and pressing these sleeves to secure the end of the rope to the sling body. This makes an economical sling and in most cases one that will give satisfactory service. A drawback to this type of sling is that the lifting capacity of the sling depends 100% upon the integrity of the pressed or swaged joint. Should the metal sleeve(s) fail, the entire eye will also fail.

The flemish eye splice is fabricated by opening or unlaying the rope body into two parts, one having three strands and the other having the remaining three strands and the core. The rope is unlayed far enough back to allow the loop or eye to be formed by looping one part in one direction and the other part in the other direction and laying the rope back together. The strands are rolled back around the rope body. A metal sleeve is then slipped over the ends of the splice and pressed (swaged) to secure the ends to the body of the sling. Nominal splice efficiencies expressed in table 4 and in the rated capacity tables are based on this splicing method. Splice efficiencies for other splicing methods should be confirmed by the sling manufacturer.

TABLE 4		
NOMINAL SPLICE EFFICIENCIES		
MECHANICAL SPLICED SLINGS		
IMPROVED PLOW STEEL:		
Diameter	IWRC	FIBER CORES
1/4 through 1"	.95	.925
1 1/16 through 2"	.925	.90
2 1/16 & larger	.90	Not Established
EXTRA IMPROVED PLOW STEEL:		
1/4 through 1"	.95	
1 1/16 through 2"	.925	
2 1/16 & larger	.90	
STAINLESS STEEL, 302 & 304 GRADE:		
1/4 through 1"	.95	
1 1/16 through 2"	.925	
2 1/16 & larger	.90	

Notice that the splice efficiency factor plays no role in the calculation of the Choker Hitch rated capacity. This is because as the rope passes through the eye of the sling in a choke, the weakest part of the sling is in the body of the sling at the choke point. Thus the splice being higher in efficiency, has no effect on the rated capacity, because the efficiency factors are not additive.

Rated capacities for single part, choker and basket hitches are calculated exactly the same as for hand tucked slings except for the nominal splice efficiencies. The rated capacities adjustment table 1 for choker hitches also applies for mechanical splice slings. Minimum D/d ratio for basket hitches is 25. This larger D/d ratio is required because the Nominal Splice Efficiency is higher.

GENERAL PRECAUTIONS are no different from other slings except care should be taken not to deform or damage the sleeve.

Stainless Steel slings which have sleeves made of a different grade or type metal than the rope body may experience accelerated deterioration due to an electro chemical reaction between the two metals. This is particularly evident in salt water or brackish conditions.

ZINC OR RESIN POURED SOCKET TYPE TERMINATIONS

While some people may debate whether zinc or resin poured sockets are truly slings, they are generally included in the sling category. This type of termination has traditionally been the method for determining the rope's actual breaking strength. All other types of end terminations have been compared to poured sockets. Their efficiency is therefore established to be 100% for all grades and constructions of rope.

Choker hitches are not used as much with poured sockets as with the other more general types of slings. When such slings are used in a choker hitch, the rated capacity adjustment table 1 applies.

Rope assemblies with poured attachments are generally used as a straight tension member where the rope body does not contact the load and is otherwise kept free from distortion or physical abuse. In such cases the minimum recommended design factor is 3.0. If the assembly is used as a sling then a design factor of 5.0 should be used to calculate the rated capacity. Rated capacities for these slings used in basket hitches are the same as mechanical spliced slings and use the same D/d ratio factors.

Length tolerances for poured attachments can be somewhat more stringent than other types of slings. The manufacturer should be contacted and agreement reached before the order is placed. Tolerance as small as plus or minus 1/8" is not out of the ordinary for this type of assembly. Specifications such as type of fitting, pin orientation, whether zinc or resin is to be used and type of application should also be supplied to the manufacturer when ordering these types of assemblies. Those inexperienced in the socketing process should not try to fabricate assemblies without first getting expert training. It is far better to leave fabrication of this type of assembly to the experts. The following socketing methods are general in nature and have withstood the test of time. Slight variations to these methods will produce equal results.

The two procedures, while achieving the same end result, differ significantly. It is highly recommended that all poured sockets whether they be zinc or resin, be proofloaded.

CABLE-LAID WIRE ROPE SLINGS

Cable-Laid Slings are fabricated from a machine made rope comprised of seven small wire ropes. The cable-laid body is typically 7x7x7, 7x7x19, or 7x6x19 Classification IWRC. This construction makes for a pliable rope and sling. These slings are used where flexibility and resistance to kinking and setting are more important than resistance to abrasion. Since the rope is made up of many smaller wire ropes, the slings can bend around smaller diameters without taking a permanent set or a kink. The many small wires are susceptible to abrasion.

The rated capacity adjustment Table 1 for choker hitches applies to cable-laid slings as well. Note the difference in the efficiency factor for calculating vertical choker hitch rated capacities.

Rated capacity for a basket hitch is based on a D/d ratio of 10, where "d" is the diameter of the cable-laid fabric. Tolerances and minimum sling lengths are also figured using the cable-laid fabric diameter.

BRAIDED MULTI-PART SLINGS

Multi-part braided slings or Multi-Parts as they are known, are generally hand fabricated slings which are "braided" from 2, 3, 4 and up to as many as 48 pieces or parts of rope. Generally 4, 6, 8 & 9 parts are the more common. They can be either flat or round and offer the ultimate in flexibility and versatility. These are truly the heavy weights of the lifting industry. This book covers only the round type slings. They snug up tightly to the load in a choker hitch and resist kinking and setting. Loads in excess of 4000 tons have been lifted with multi-part slings.

Nominal Splice Efficiency for multi-part slings is 0.70 for component ropes 3/32" through 2" diameters. For larger component rope slings, consult the sling manufacturer for splice efficiencies.

Because of the multi-rope component construction, multi-part slings react differently than standard wire rope slings in a choker hitch therefore the nominal splice efficiency is present in the equation. The adjustment Table 1 applies to multi-part slings also.

Rated Capacity for a basket hitch is based on a minimum D/d ratio of 25, where "d" = component rope diameter.

Length tolerances for component ropes of 3/8" diameter and smaller are plus or minus 10 component rope diameters, or plus or minus 1.5% of the sling length whichever is greater. The legs of matched slings shall be within 5 component rope diameters of each other. For component rope diameters 7/16" and larger, the tolerance is plus or minus 6 component rope diameters, or plus or minus 1% of the sling length whichever is the greater. Legs of matched slings shall be within 3 component rope diameters of each other.

Minimum Sling Length between loops, sockets or sleeves is recommended to be 40 times the component rope diameter of the braided body.

GROMMETS

Grommets are a unique type of sling. They form a complete circle and automatically double the number of lifting legs. Several types are available, such as strand laid hand tucked, strand laid mechanical, cable laid hand tucked and cable laid mechanical. Grommets work well in basket and choker hitches and general applications will find them used in this manner. Another unique advantage to grommets is that the load contact points may be rotated or moved around the sling to even out the wear points. The only area that should not come into contact with the load is the splice area. The sling manufacturer will usually mark the area of hand tucked grommets with paint to help the user more easily identify the splice area.

Tolerances for grommets are generally plus or minus 1% of the circumferential length or 6 body diameters whichever is greater.

A minimum circumference of 96 body diameters is recommended. This measurement is normally an inside circumferential measurement. The requirement for a minimum circumference of 96 times the body diameter for grommets and endless slings was based on the require-

ment to have at least three free rope lays on either side of the tuck of a hand spliced endless grommet prior to being bent around a hook or pin five times the body diameter. To eliminate the possibility of confusion, this requirement was adopted for mechanically spliced endless grommets as well. Consult the sling manufacturer for smaller circumferences.

The same general precautions apply to grommets as apply to all other types of slings. However, it should be noted that since a grommet is a continuous circle, the D/d ratio becomes a very important consideration. The D/d ratio must be applied to the lifting pins as well as to the load. Normally the lifting pins will be the smallest diameter in the system other than the diameter of the grommet. No loads should be handled on D/d smaller than 5 times the sling body diameter. If they must, consult the sling manufacturer. Rated capacities covered in this section are based on a D/d ratio of 5.

STRAND LAID HAND TUCKED GROMMET

A Strand Laid Hand Tucked Grommet is made from one continuous length of strand. No sleeves are used to make the joint. This results in a very smooth circular sling.

TABLE 6			
NOMINAL SPLICE EFFICIENCIES			
STRAND LAID TUCKED GROMMETS			
Rope Dia.	Nominal Eff. Factor	Rope Dia.	Nominal Eff. Factor
1/4	.78	1 3/8	.745
5/16	.78	1 1/2	.735
3/8	.78	1 5/8	.730
7/16	.78	1 3/4	.725
1/2	.78	1 7/8	.720
9/16	.78	2	.715
5/8	.78	2 1/8	.710
3/4	.78	2 1/4	.705
7/8	.78	2 3/8	.700
1	.775	2 1/2	.695
1 1/8	.765	2 3/4	.690
1 1/4	.755	3	.685

Because of the sling body construction, grommet slings react differently than standard wire rope slings in a choker type hitch therefore the presence of the nominal splice efficiency factor in the equation. Rated capacity adjustment Table 1 applies.

STRAND LAID MECHANICAL SPLICE GROMMET

Strand Laid Mechanical Splice grommets are made from one continuous length of wire rope joined by pressing or swaging one or more sleeves over the rope juncture. This type of grommet is not as smooth as the hand tucked, but offers economy and ease of manufacture. An advantage is that the swaged sleeves give clear indication of the splice area.

CABLE LAID HAND TUCKED GROMMET

Cable Laid Hand Tucked Grommets are fabricated in the same manner as strand laid hand tucked grommets except one continuous length of wire rope is used. This makes for a flexible smooth sling. The body diameters are somewhat odd sized because the grommet body is built up from a standard diameter component rope.

CABLE LAID MECHANICAL SPLICE

(See Rated Capacity Tables Section)

Cable Laid Mechanical Splice Grommets are fabricated from one continuous length of cable laid wire rope fabric with the ends joined by one or more mechanical sleeves. They are similar to strand laid mechanical splice grommets, but offer greater flexibility.

TABLE 7			
NOMINAL SPLICE EFFICIENCIES			
CABLE LAID HAND TUCKED GROMMETS			
Rope Dia.	Nominal Eff. Factor	Rope Dia.	Nominal Eff. Factor
3/8	.78	1 11/16	.750
9/16	.78	1 7/8	.745
5/8	.78	2 1/4	.735
3/4	.775	2 5/8	.725
15/16	.770	3	.715
1 1/8	.765	3 3/8	.705
1 1/2	.755		

WIRE ROPE SLINGS

GUIDELINES FOR THE RIGGER

2

Some Useful Guidelines For the Rigger

On the following pages are some useful tips to help the rigger do his job more efficiently and safely. Prevailing work rules and government regulations place full responsibility for proper performance upon the rigger, so it is his duty to be familiar with the condition and capability of all tools and equipment used, as well as techniques employed. One basic rule always applies: Always know...never guess.

Each lift may be divided into three parts, providing a convenient plan for proceeding:

1. The Lifting Device—Know its capability and limitations, and its condition. When was it last inspected? If in doubt about capacity, check the placard.
2. The Hitch—Here is where the rigger can exercise ingenuity...but it's also the easiest place to make a mistake.
3. The Load—The weight must be known. But you must also protect the load from possible damage by the slings...and protect the slings from damage by the load.

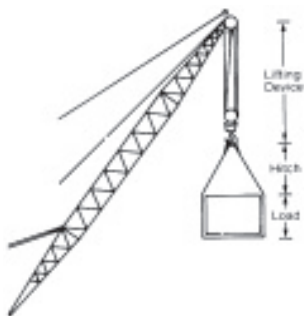

Is the lifting device adequate?

Check the placard on the crane or hoist, and then answer three questions:

1. Is capacity adequate for this lift?
2. Will it lift high enough?
3. Is horizontal reach adequate?



Check the hook and reeving.

1. Are sheaves properly rigged? If multi-part reeving, will it support the load?
2. Is the hook the right size so sling eye won't be distorted when put over the hook?
3. Check for cracks in bowl of the hook, and for evidence of point loading or bending to one side of 15% or more.

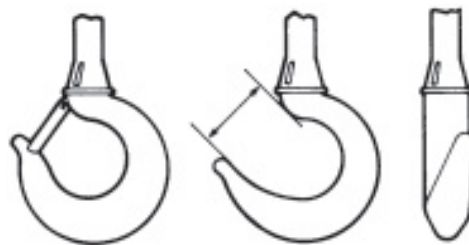

Type of Hitch Determines Choice of Sling

Before you select a sling for a specific lift, determine the most effective hitch to do the job, protect the load, and protect the sling. One of three basic hitches will usually do the job.

The type of hitch you select may determine the type of sling body that will best do the job, as well as the length of sling that will be needed. Lifting height, overhead clearance and hook travel will affect choice of hitch and length of sling.

Choose a sling body type which will best support the load while providing adequate rated capacity. The proper choice will provide:

1. Lifting capacity needed.
2. Proper D/d Ratio.
3. Handling characteristics needed for rigging.
4. Minimal damage to the sling.
5. Minimal damage to the load.



WIRE ROPE SLINGS

Protect the sling during the lift with blocking or padding at sharp corners or where the sling body would be bent severely.

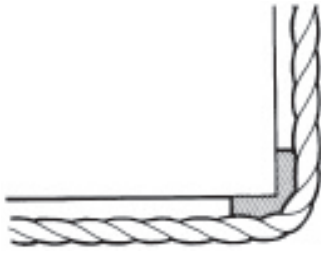

Use a spreader bar between legs of a sling to prevent excessive side pressure on the load by the sling during the lift.

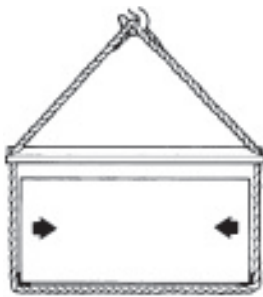

When attaching a sling to eye bolts, always pull on line with the bolt axis. When hitching to bolts screwed into or attached to a load, a side pull may break the bolts.

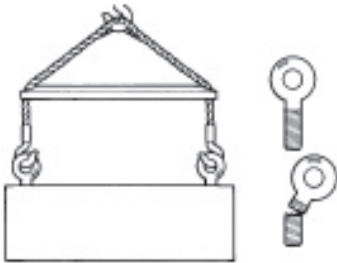

Use a shackle in the sling eye during a choke to protect sling body against excessive distortion. Always put shackle pin through sling eye, rather than against the sling body—since sliding movement of sling body could rotate pin, causing it to come loose.



A sliding hook choker is superior to a shackle or unprotected eye, since it provides a greater bending radius for the sling body.

Use blocking or padding to protect hollow vessels, loose bundles and fragile items from scuffing and bending. Remember that blocking becomes part of the lift, and must be added to total weight on the sling.

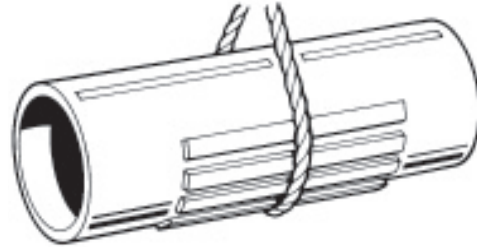

When lifting crates or wooden boxes with a basket hitch, be sure load can withstand side pressure as tension is applied to sling. Use spreader bars and corner protectors to prevent damage to contents.



When lifting a bundled load with a single sling near the center of gravity, a choke is more effective than a basket hitch to prevent unbalance and slipping of the load in the sling.

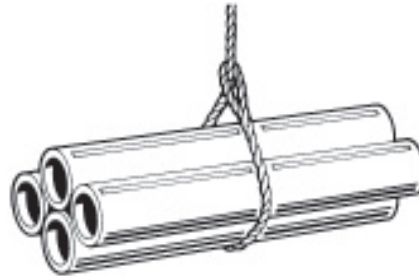

Some riggers will use a double wrap around the load, for 360° gripping of the load, to prevent slippage during the lift.



WIRE ROPE SLINGS

2

You can reduce the angle of a choke with a wooden block, or blocks, between the hitch and the load. This also increases the angle between the two legs to improve sling efficiency.

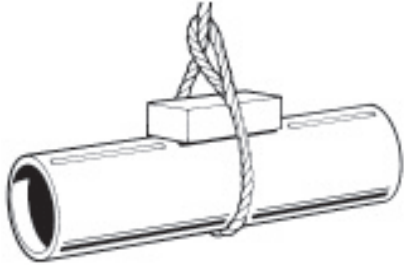

When rigging two or more straight slings as a bridle, select identical sling constructions of identical length—with identical previous loading experience. Normal stretch must be the same for paired slings to avoid overloading individual legs and unbalancing the load during the lift.

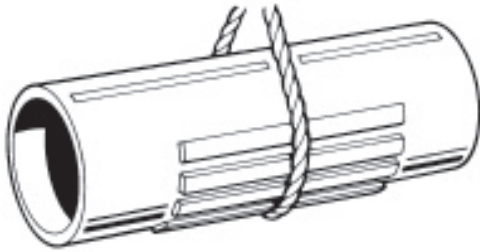

Single-part hand-spliced slings must not be permitted to rotate when rigged in a straight, vertical hitch. Rotation can cause the splice to unlay and pull out, resulting in dropping of the load.

WARNING

Hand-spliced slings should not be used in lifts where the sling may rotate and cause the wire rope to unlay.

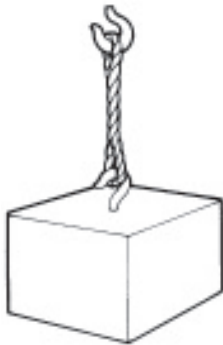

Anytime a load is lifted beyond arm's reach with a single-part load line or straight eye-and-eye sling, use a tagline to prevent load rotation. If a wire rope is permitted to rotate, the strands may unlay and the rope's capacity will be reduced.

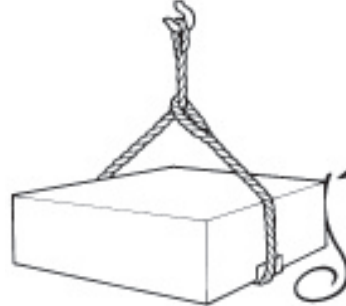

Two basket hitches can be rigged with two slings to provide better balance for long loads. Be sure that slings cannot slide toward one another along the load when the lift is made.

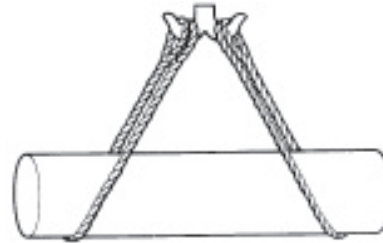

Use an equalizing bar with double basket hitches to reduce tendency of slings to slide together, and to keep loads level. By adjusting the hook point and using a come-along or chain block to support the heavy end, the load can be kept level during the lift.



Proper Use of Cribbing



Incorrect

Proper Use of Cribbing



Correct

To turn or reposition a load, either one or two lifting devices may be employed. Always use a choker hitch or a single-leg direct attachment. Never attempt to turn a load with a basket, since the load will slide in the hitch, against the sling body—resulting in damage to both the sling and the load, and possibly a dropped load.

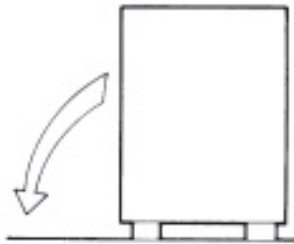

One Hook Load Turning

To turn a load with one hook, attach the sling directly to the load ABOVE the Center of Gravity. The lifting hook must be able to move, or travel, in the direction of the turn to prevent sliding of the pivot edge of the load just as the load leaves the ground. It may be necessary to lift the load clear to reposition it after the turn is completed, and irregular shapes sometimes will require blocking for support during and after the turn.

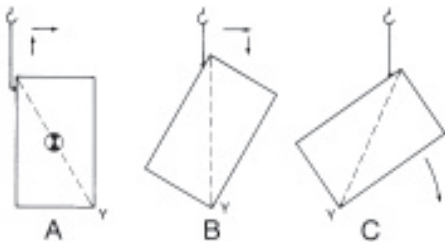

Two-hook turning is employed when it is desired to turn the load freely in the air. Main and auxiliary hoists of a crane can often be used, or two cranes can be used.

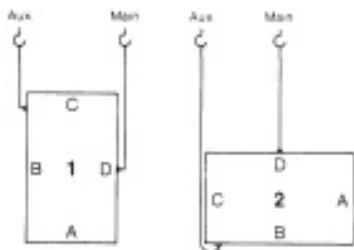

To turn from side (A) to (B) in 1 & 2 above, attach on side (B) above the Center of Gravity and on side (D) at the Center of Gravity, then lift both hoists equally until load is suspended. Lower auxiliary until turn is completed; detach sling at (B) before lowering load completely.

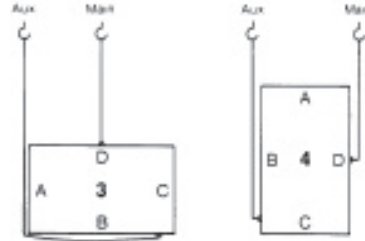

To turn from side (B) to (C) in 3 & 4 above, lift balanced load at (D) directly above the Center of Gravity; then attach auxiliary at (B) and lift to desired position. Lower both hooks simultaneously until side (C) is in desired position.



Turning with double choker gives good control, with weight always applied against a tight sling body and no movement between sling and load. To rig, place both eyes on top of load, pointing opposite direction of turn. Body of sling is then passed under load, through both eyes and over lifting hook. Blocking should be used under load to protect sling and facilitate removal.

Lifting unbalanced loads when exact length slings are not available can be accomplished by rigging a choke on the heavy end, as right. Length can be adjusted before weight applies, but once the load comes onto the sling, the hitch is locked in position for the lift.

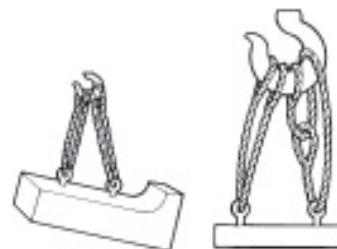

Center of Gravity of a rectangular object with homogeneous characteristics will usually be below the junction of lines drawn diagonally from opposite corners. When a rectangular object has weight concentrated at one end, Center of Gravity will be situated toward that end—away from the intersection of diagonal lines. To avoid an unbalanced lift, the lifting hook must be rigged directly above the Center of Gravity.

2

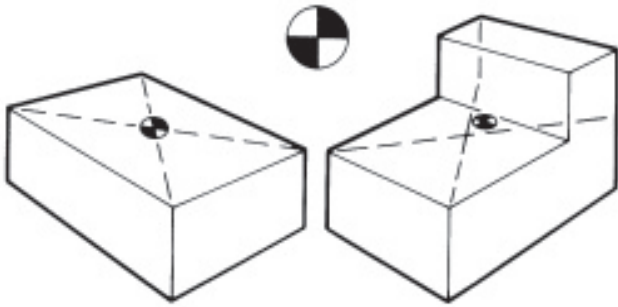

To locate the approximate Center of Gravity of an irregularly shaped article, visualize it enclosed by a rectangle. Where diagonals from opposite corners intersect will usually provide a lift point near the Center of Gravity.

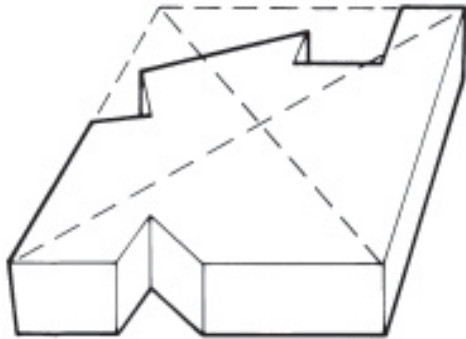

Overturning a heavy object onto cribbing, using one lifting hook and chainblock. To upend the object, chainblock "A" and the sling "B" should exchange positions.

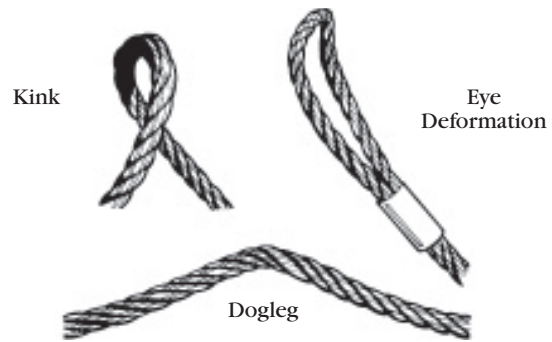
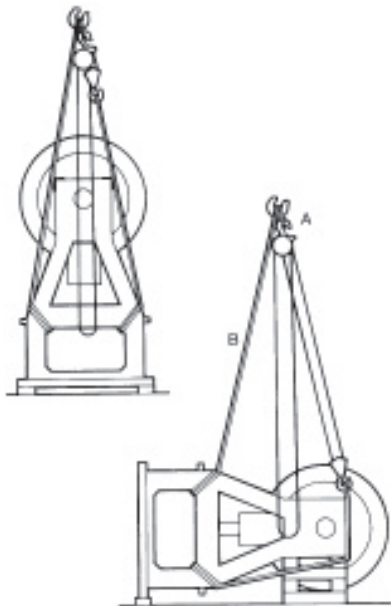

Doglegs, Sets and Kinks

When a loop is "pulled through," it forms a kink which permanently deforms a wire rope by freezing or locking wires and strands. This prevents them from sliding and adjusting, and reduces rope strength.

A dogleg is a "set" which occurs when a wire rope sling is pulled down snug against a load. A dogleg usually can be "rolled back" or turned inside out, and usefulness of the sling restored, since strands can still adjust.

Eye deformation is ordinarily not detrimental to sling strength as long as there are no broken wires or gross distortion of the lay of strands. An eye has two legs, so has adequate strength for the load the body can carry. A sling should be retired when distortion locks the strands or flattens the rope in the eye so strands cannot move and adjust.

Rigger's Check List

1. Analyze and Measure—Determine the total weight to be moved as well as exactly how far it is to move and how high it must be lifted.
2. Determine the Hitch—Decide how the load is to be connected to the lifting hook and how the sling will grip, or be attached to, the load.
3. Select the Sling—In addition to adequate Rated Capacity for the angles and hitch involved, the sling body should be of the type and style best suited to handling this specific load. Select a sling with proper end attachments or eye protection, as well as attachment hardware such as clevises.
4. Inspect the Sling—Make a good visual check of the sling you select to determine if it is in good condition and capable of making the lift. Refer to prevailing OSHA and ANSI regulations for inspection criteria.
5. Rig Up, Not Down—Always attach the sling to the load first, then attach it to the hook.
6. Check Everything—Before attempting a lift, take a light strain on the rigging, checking to see that blocking, sling and load protection and all safety devices are in place.
7. Stand Clear and Lift—Let the lifting device and rigging do the job—don't use brute strength to prevent swinging or movement. Use a tagline, or tether, to control any movement. Keep all hands and toes out from under the load when it is suspended.
8. Don't Jerk!—Lift slowly and with a steady application of power.
9. Put It Away!—After you've completed the job, check the sling for any damage (If it's damaged, red tag it immediately or advise the sling inspector.), then return it to the sling storage rack for safekeeping until next usage.

WIRE ROPE SLINGS

USA Standard Crane Hand Signals

2



Use Main Hoist. Tap fist on head; then use regular signals.



Use Whipline (Auxiliary Hoist). Tap elbow with one hand, then use regular signals.



Raise Boom. Arm extended, fingers closed, thumb pointing upward.



Lower Boom. Arm extended, fingers closed, thumb pointing downward.



Hoist. With forearm vertical, forefinger pointing up, move hand in small horizontal circle.



Lower. With arm extended downward, forefinger pointing down, move hand in small horizontal circles.



Raise the Boom and Lower the Load. With arm extended, thumb pointing up, flex fingers in and out as long as load movement is desired.



Lower the Boom and Raise the Load. With arm extended, thumb pointing down, flex fingers in and out as long as load movement is desired.



Travel. Arm extended forward, hand open and slightly raised, make pushing motion in direction of travel.



Swing. Arm extended, point with finger in direction of swing of boom.



Extend Boom (Telescoping Booms). Both fists in front of body with thumbs pointing outward.



Retract Boom (Telescoping Booms). Both fists in front of body with thumbs pointing toward each other.



Travel. (One Track). Lock the track on side indicated by raised fist. Travel opposite track in direction indicated by circular motion of other fist, rotated vertically in front of body. (For crawler cranes only).



Travel (Both Tracks). Use both fists in front of body, making a circular motion about each other, indicating direction of travel; forward or backward. (For crawler cranes only.)



Extend Boom (Telescoping Boom). One Hand Signal. One fist in front of chest with thumb tapping chest.



Retract Boom (Telescoping Boom). One Hand Signal. One fist in front of chest, thumb pointing outward and heel of fist tapping chest.

Additional Signals for Bridge Cranes

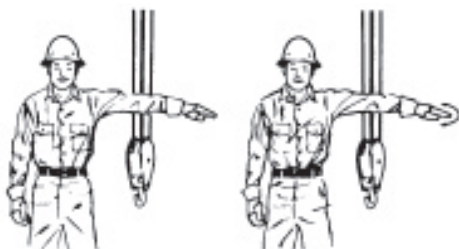

Stop. Arm extended, palm down, hold position rigidly.

Emergency Stop. Arm extended, palm down, move hand rapidly right and left.

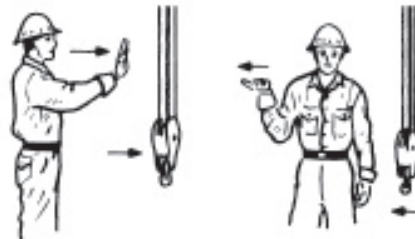

Bridge Travel. Arm extended forward, hand open and slightly raised, make pushing motion in direction of travel.

Trolley Travel. Palm up, fingers closed, thumb pointing in direction of motion, jerk hand horizontally.

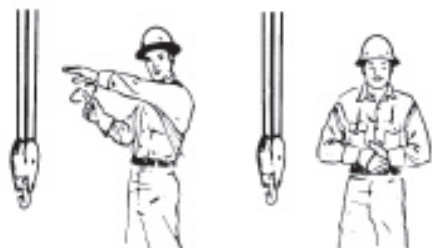

Move Slowly. Use one hand to give any motion signal and place other hand motionless in front of hand giving the motion signal. (Hoist slowly shown as example.)

Dog Everything. Clasp hands in front of body.

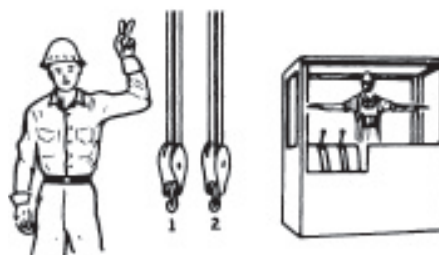

Multiple Trolleys. Hold up one finger for block marked "1" and two fingers for block marked "2". Regular signals follow.

Magnet is Disconnected. Crane Operator spreads both hands apart palms up.

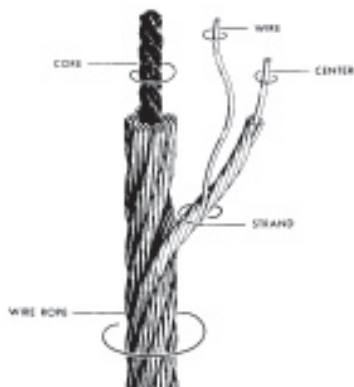

Temperature, Lubrication, Moisture Are Factors In Proper Storage

Care of Slings

The amount of care and proper maintenance a sling receives will go a long way in determining its service life. Following are guidelines which experience has shown helpful.

Storage: Proper storage requires that slings be kept in an area where they will not be exposed to water, extreme heat, or corrosive fumes, liquids, and sprays, of being run over or kinked.

Slings should never be left beneath loads or lying around where they may be damaged. All slings, when not in use, should be kept on a rack. Use of a rack minimizes accidental damage and allows easier monitoring of condition

between regular inspections. A rack will also save time by allowing larger slings to be picked up and returned by crane, thereby reducing manhandling.

Effects of Temperature

All wire rope should be protected from extremes of temperature. The accepted rules are: Fiber core slings should never be exposed to temperature in excess of 200°F. Steel cored slings should never be used at temperatures above 400°F or below minus 60°F.

It is not always easy to detect when wire rope has been damaged by heat. The most common visual signs are loss of lubrication and discoloration of wires.

The best practice to follow is that if there is the slightest suspicion that a sling was subjected to high temperatures, it should be taken out of service immediately. If it is absolutely necessary to use slings outside of the above temperature range, the sling manufacturer should be consulted.

Lubrication

Like any other machine, wire rope is thoroughly lubricated at time of manufacture. Normally, for sling use under ordinary conditions, no additional lubrication is required. However, if a sling is stored outside or in an environment which would cause corrosion, lubrication should be applied during the service life to prevent rusting or corroding.

If relubrication is indicated, the same type lubricant applied during manufacture should be used. Your sling manufacturer can provide information on the type of lubricant to be used and best method of application.

WIRE ROPE SLING INSPECTION & REMOVAL CRITERIA

Basic Inspection Criteria For Wire Rope Slings

The goal of a sling inspection is to evaluate remaining strength in a sling which has been used previously to determine if it is suitable for continued use.

Specific inspection intervals and procedures are required by the Occupational Safety and Health Act (OSHA) and by ANSI B30.9 Regulations, and the responsibility for performance of inspections is placed squarely upon the sling user by Federal Legislation.

As a starting point, the same work practices which apply to all "working" wire ropes apply to wire rope which has been fabricated into a sling. Therefore, a good working knowledge of wire rope design and construction will be not only useful but essential in conducting a wire rope sling inspection.

But because wire rope is a rather complex machine, no precise rules can be given to determine exactly when a wire rope sling should be replaced. There are many variables, and all must be considered.

OSHA specifies that a wire rope sling shall be removed from service immediately if ANY of the following conditions are present:

1. **Broken Wires:** For single-part slings, 10 randomly distributed broken wires in one rope lay, or five broken wires in one strand of one rope lay. For multi-part slings these same criteria apply to each of the component ropes. For this inspection, a broken wire shall only be counted once; that is, each break should have two ends.
 2. **Metal Loss:** Wear or scraping of one-third the original diameter of outside individual wires. This is quite difficult to determine on slings and experience should be gained by the inspector by taking apart old slings and actually measuring wire diameters.
 3. **Distortion:** Kinking, crushing, birdcaging or other damage which distorts the rope structure. The main thing to look for is wires or strands that are pushed out of their original positions in the rope. Slight bends in a rope where wires or strands are still relatively in their original positions would not be considered serious damage. But good judgment is indicated.
 4. **Heat Damage:** Any metallic discoloration or loss of internal lubricant caused by exposure to heat.
 5. **Bad End Attachments:** Cracked, bent or broken end fittings caused by abuse, wear or accident.
 6. **Bent Hooks:** No more than 15 percent over the normal throat openings, measured at the narrowest point, or twisting of more than 10 degrees is permissible.
 7. **Metal Corrosion:** Severe corrosion of the rope or end attachments which has caused pitting or binding of wires should be cause for replacing the sling. Light rusting usually does not affect strength of a sling, however.
- In addition to these seven conditions specified by OSHA, the following are also important:
8. **Pulled Eye Splices:** Any evidence that eye splices have slipped, tucked strands have moved, or pressed sleeves show serious damage may be sufficient cause to reject a sling.
 9. **Unbalance:** A very common cause of damage is the kink which results from pulling through a loop while using a sling, thus causing wires and strands to be deformed and pushed out of their original position. This unbalances the sling, reducing its strength.

Disposition of Retired Slings: the best inspection program available is of no value if slings which are worn out and have been retired are not disposed of properly. When it is determined by the inspector that a sling is worn out or damaged beyond use, it should be tagged immediately **DO NOT USE**.

This sling should then be destroyed as soon as possible by cutting the eye and fittings from the rope with a torch. This will help assure that an employee will not mistakenly use a sling which has been retired from service.

It should also be obvious that a good inspection program will not only provide safer lifting conditions, but will also extend the life of slings and thereby reduce lifting costs.

Federal Work Rules Require Specific Inspection Intervals

Government regulations are also specific on WHEN to inspect.

Both ANSI Standard B30.9 and OSHA require that wire rope slings receive two types of inspections: a DAILY visual inspection, and additional inspections where service conditions warrant.

Daily visual inspections are intended to detect serious damage or deterioration which would weaken the sling. This inspection is usually performed by the person using the sling in a day-to-day job. He should look for obvious things, such as broken wires, kinks, crushing, broken attachments, severe corrosion, etc.

Additional inspections should be performed at regular intervals based on, (1) frequency of sling use, (2) severity of service conditions, (3) nature of lifts, and (4) prior experience based on service life of slings used in similar circumstances.

It is required that these additional inspections be carried out by a designated person who must have good knowledge of wire rope. An accurate WRITTEN and dated record of all conditions observed should be kept. Any deterioration of the sling which could result in appreciable loss of original strength should be carefully noted, and determination made on whether further use would constitute a safety hazard.

How to Inspect

Precisely how to make proper, adequate inspections is not detailed by OSHA—yet it is in the HOW of inspection that the big difference between a good inspection and something less become apparent.

Inspection should follow a systematic procedure:

- (1) First, it is necessary that all parts of the sling are readily visible. The sling should be laid out so every part is accessible.
- (2) Next, the sling should be sufficiently cleaned of dirt and grease so wires and fittings are easily seen. This can usually be accomplished with a wire brush or rags.
- (3) The sling should then be given a thorough, systematic examination throughout its entire length, paying particular attention to sections showing the most wear.
- (4) Special attention should also be paid to fittings and end attachments, and areas of the sling adjacent to these fittings.
- (5) When the worst section of a sling has been located, this area should then be carefully checked against the OSHA criteria.
- (6) Label or identify slings that are inspected.
- (7) Keep records of inspections that include dates and corresponding conditions of slings.
- (8) Dispose immediately of slings that are rejected.

A knowledgeable inspector will also insist on proper storage for out-of-use slings—to make his job easier if not for the good of the slings. Inspections are much easier—and probably more thorough—when slings are available for inspection in an orderly arrangement, out of the weather, away from heat and dirt.

Sling Leg Options

Standard End Fitting Combinations

To order sling legs, follow the criteria listed in pages 2-1 to 2-15. Choose the correct size from the tables on the following pages. Determine the length needed and specify the end fittings required from the list of combinations shown below.

2



Eye & Eye



Eye & Thimble



Eye & Hook



Eye & Crescent Thimble



Eye & Slip-Thru Thimble

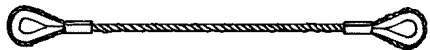

Thimble & Thimble



Thimble & Hook



Eye and Screw Pin Anchor Shackle



Thimble & Slip-Thru Thimble



Eye and Open Swage Socket



Eye and Closed Swage Socket



Slip-Thru Thimble & Hook



Slip-Thru Thimble & Slip-Thru Thimble

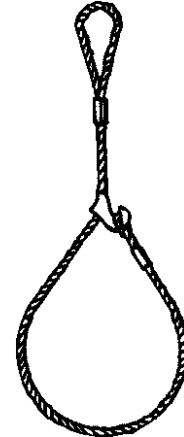

Eye & Thimble with Sliding Choker Hook

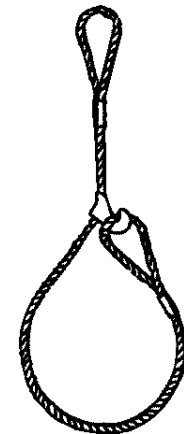

Eye & Eye with Sliding Choker Hook

WIRE ROPE SLINGS

1-PART SLINGS/MECHANICAL SPLICE

Single Leg Slings



2

EXTRA IMPROVED PLOW STEEL IWRC
RATED CAPACITY IN TONS

CERTEX Cat. Ref. No.	ROPE DIAMETER (INCHES)	BASKET AT DEGREES					
		VERTICAL	CHOKER	VERTICAL BASKET	BASKET AT DEGREES		
					30 DEGREE	45 DEGREE	60 DEGREE
CX02-0001	1/4	0.65	0.48	1.3	0.65	0.91	1.1
CX02-0002	5/16	1.0	0.74	2.0	1.0	1.4	1.7
CX02-0003	3/8	1.4	1.1	2.9	1.4	2.0	2.5
CX02-0004	7/16	1.9	1.4	3.9	1.9	2.7	3.4
CX02-0005	1/2	2.5	1.9	5.1	2.5	3.6	4.4
CX02-0006	9/16	3.2	2.4	6.4	3.2	4.5	5.5
CX02-0007	5/8	3.9	2.9	7.8	3.9	5.5	6.8
CX02-0008	3/4	5.6	4.1	11	5.6	7.9	9.7
CX02-0009	7/8	7.6	5.6	15	7.6	11	13
CX02-0010	1	9.8	7.2	20	9.8	14	17
CX02-0011	1 1/8	12	9.1	24	12	17	21
CX02-0012	1 1/4	15	11	30	15	21	26
CX02-0013	1 3/8	18	13	36	18	25	31
CX02-0014	1 1/2	21	16	42	21	30	37
CX02-0015	1 5/8	24	18	49	24	35	42
CX02-0016	1 3/4	28	21	57	28	40	49
CX02-0017	1 7/8	32	24	64	32	46	56
CX02-0018	2	37	28	73	37	52	63
CX02-0019	2 1/8	40	31	80	40	56	69
CX02-0020	2 1/4	44	35	89	44	63	77
CX02-0021	2 3/8	49	38	99	49	70	85
CX02-0022	2 1/2	54	42	109	54	77	94
CX02-0023	2 5/8	60	46	119	60	84	103
CX02-0024	2 3/4	65	51	130	65	92	113
CX02-0025	2 7/8	71	55	141	71	100	122
CX02-0026	3	77	60	153	77	108	132
CX02-0027	3 1/8	82	64	165	82	117	143
CX02-0028	3 1/4	89	69	177	89	125	153
CX02-0029	3 3/8	95	74	190	95	135	165
CX02-0030	3 1/2	102	79	203	102	144	176
CX02-0031	4	130	101	260	130	183	224
CX02-0032	4 1/2	160	124	320	160	225	276

RATED CAPACITIES BASKET HITCH BASED ON D/d RATIO OF 25

RATED CAPACITIES BASED ON PIN DIAMETER NO LARGER THAN NATURAL EYE WIDTH OR LESS THAN THE NOMINAL SLING DIAMETER

RATED CAPACITIES BASED ON DESIGN FACTOR OF 5

HORIZONTAL SLING ANGLES LESS THAN 30 DEGREES SHALL NOT BE USED

Rated Capacities shown apply only to 6x19 and 6x37 classification wire rope.

WIRE ROPE SLINGS

1-PART SLINGS/MECHANICAL SPLICE

2-Leg Bridle Slings

EXTRA IMPROVED PLOW STEEL IWRC
RATED CAPACITY IN TONS

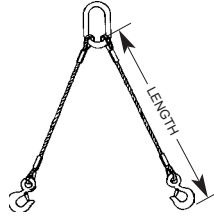

Standard Style

2

CERTEX Cat. Ref. No.	ROPE DIAMETER (INCHES)	VERTICAL	2 LEG BRIDLE		
			30 DEGREE	45 DEGREE	60 DEGREE
CX02-0033	1/4	1.3	0.65	0.91	1.1
CX02-0034	5/16	2.0	1.0	1.4	1.7
CX02-0035	3/8	2.9	1.4	2.0	2.5
CX02-0036	7/16	3.9	1.9	2.7	3.4
CX02-0037	1/2	5.1	2.5	3.6	4.4
CX02-0038	9/16	6.4	3.2	4.5	5.5
CX02-0039	5/8	7.8	3.9	5.5	6.8
CX02-0040	3/4	11	5.6	7.9	9.7
CX02-0041	7/8	15	7.6	11	13
CX02-0042	1	20	9.8	14	17
CX02-0043	1 1/8	24	12	17	21
CX02-0044	1 1/4	30	15	21	26
CX02-0045	1 3/8	36	18	25	31
CX02-0046	1 1/2	42	21	30	37
CX02-0047	1 5/8	49	24	35	42
CX02-0048	1 3/4	57	28	40	49
CX02-0049	1 7/8	64	32	46	56
CX02-0050	2	73	37	52	63

RATED CAPACITIES BASKET HITCH BASED ON D/d RATIO OF 25

RATED CAPACITIES BASED ON PIN DIAMETER NO LARGER THAN NATURAL EYE WIDTH OR LESS THAN THE NOMINAL SLING DIAMETER

RATED CAPACITIES BASED ON DESIGN FACTOR OF 5

HORIZONTAL SLING ANGLES LESS THAN 30 DEGREES SHALL NOT BE USED

Rated Capacities shown apply only to 6x19 and 6x37 classification wire rope.

WIRE ROPE SLINGS

1-PART SLINGS/MECHANICAL SPLICE

3-Leg Bridle Slings

EXTRA IMPROVED PLOW STEEL IWRC
RATED CAPACITY IN TONS

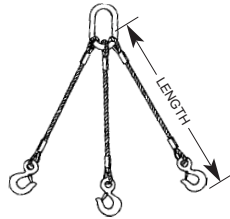

Standard Style

2

CERTEX Cat. Ref. No.	ROPE DIAMETER (INCHES)	3 LEG BRIDLE			
		VERTICAL	30°	45°	60°
CX02-0051	1/4	1.9	0.97	1.4	1.7
CX02-0052	5/16	3.0	1.5	2.1	2.6
CX02-0053	3/8	4.3	2.2	3.0	3.7
CX02-0054	7/16	5.8	2.9	4.1	5.0
CX02-0055	1/2	7.6	3.8	5.4	6.6
CX02-0056	9/16	9.6	4.8	6.8	8.3
CX02-0057	5/8	12	5.9	8.3	10
CX02-0058	3/4	17	8.4	12	15
CX02-0059	7/8	23	11	16	20
CX02-0060	1	29	15	21	26
CX02-0061	1 1/8	36	18	26	31
CX02-0062	1 1/4	44	22	31	38
CX02-0063	1 3/8	53	27	38	46
CX02-0064	1 1/2	63	32	45	55
CX02-0065	1 5/8	73	37	52	63
CX02-0066	1 3/4	85	42	60	74
CX02-0067	1 7/8	97	48	68	84
CX02-0068	2	110	55	78	95
CX02-0600	2 1/8	119	60	84	103
CX02-0601	2 1/4	133	67	94	116
CX02-0602	2 3/8	148	74	105	128
CX02-0603	2 1/2	163	82	115	141
CX02-0604	2 5/8	179	89	126	155
CX02-0605	2 3/4	195	97	138	169
CX02-0606	2 7/8	212	106	150	183
CX02-0607	3	230	115	162	199
CX02-0608	3 1/8	247	124	175	214
CX02-0609	3 1/4	266	133	188	230
CX02-0610	3 3/8	286	143	202	247
CX02-0611	3 1/2	305	152	215	264

RATED CAPACITIES BASKET HITCH BASED ON D/d RATIO OF 25

RATED CAPACITIES BASED ON PIN DIAMETER NO LARGER THAN NATURAL EYE WIDTH OR LESS THAN THE NOMINAL SLING DIAMETER

RATED CAPACITIES BASED ON DESIGN FACTOR OF 5

HORIZONTAL SLING ANGLES LESS THAN 30 DEGREES SHALL NOT BE USED

Rated Capacities shown apply only to 6x19 and 6x37 classification wire rope.

WIRE ROPE SLINGS

1-PART SLINGS/MECHANICAL SPLICE



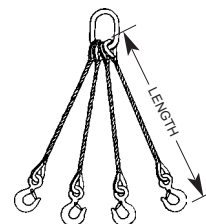

4-Leg Bridle Slings

EXTRA IMPROVED PLOW STEEL IWRC
RATED CAPACITY IN TONS



Standard Style

2

CERTEX Cat. Ref. No.	ROPE DIAMETER (INCHES)	4 LEG BRIDLE			
		VERTICAL	30°	45°	60°
					
CX02-0069	1/4	2.6	1.3	1.8	2.2
CX02-0070	5/16	4.0	2.0	2.8	3.5
CX02-0071	3/8	5.7	2.9	4.1	5.0
CX02-0072	7/16	7.8	3.9	5.5	6.7
CX02-0073	1/2	10	5.1	7.1	8.8
CX02-0074	9/16	13	6.4	9.0	11
CX02-0075	5/8	16	7.8	11	14
CX02-0076	3/4	22	11	16	19
CX02-0077	7/8	30	15	21	26
CX02-0078	1	39	20	28	34
CX02-0079	1 1/8	48	24	34	42
CX02-0080	1 1/4	59	30	42	51
CX02-0081	1 3/8	71	36	50	62
CX02-0082	1 1/2	84	42	60	73
CX02-0083	1 5/8	98	49	69	85
CX02-0084	1 3/4	113	57	80	98
CX02-0085	1 7/8	129	64	91	112
CX02-0086	2	147	73	104	127
CX02-0850	2 1/8	159	80	112	138
CX02-0851	2 1/4	178	89	126	154
CX02-0852	2 3/8	197	99	139	171
CX02-0853	2 1/2	217	109	154	188
CX02-0854	2 5/8	238	119	168	206
CX02-0855	2 3/4	260	130	184	225
CX02-0856	2 7/8	282	141	200	244
CX02-0857	3	306	153	216	265
CX02-0858	3 1/8	330	165	233	286
CX02-0859	3 1/4	354	177	250	307
CX02-0860	3 3/8	381	190	269	330
CX02-0861	3 1/2	406	203	287	352

RATED CAPACITIES BASKET HITCH BASED ON D/d RATIO OF 25

RATED CAPACITIES BASED ON PIN DIAMETER NO LARGER THAN NATURAL EYE WIDTH OR LESS THAN THE NOMINAL SLING DIAMETER

RATED CAPACITIES BASED ON DESIGN FACTOR OF 5

HORIZONTAL SLING ANGLES LESS THAN 30 DEGREES SHALL NOT BE USED

Rated Capacities shown apply only to 6x19 and 6x37 classification wire rope.

WIRE ROPE SLINGS

1-PART SLINGS/MECHANICAL SPLICE



Single Leg Slings



2

Stainless Steel Type 302 or 304 IWRC Rated Capacity in Tons

Rated Capacities Shown Apply Only to 6X19 and 6X36 Classification Wire Rope

CERTEX Cat. Ref. No. Type 302	CERTEX Cat. Ref. No. Type 304	ROPE DIAMETER (INCHES)			
			VERTICAL	CHOKER	VERTICAL BASKET
CX02-0087	CX02-0107	1/4	0.61	0.38	1.0
CX02-0088	CX02-0108	5/16	0.86	0.58	1.6
CX02-0089	CX02-0109	3/8	1.1	0.82	2.2
CX02-0090	CX02-0110	7/16	1.5	1.1	3.1
CX02-0091	CX02-0111	1/2	2.2	1.6	4.3
CX02-0092	CX02-0112	9/16	2.7	2.0	5.4
CX02-0093	CX02-0113	5/8	3.3	2.5	6.7
CX02-0094	CX02-0114	3/4	4.7	3.5	9.4
CX02-0095	CX02-0115	7/8	6.3	4.7	13
CX02-0096	CX02-0116	1	8.1	6.0	16
CX02-0097	CX02-0117	1 1/8	10	7.4	20
CX02-0098	CX02-0118	1 1/4	12	9.1	24
CX02-0099	CX02-0119	1 3/8	14	11	28
CX02-0100	CX02-0120	1 1/2	17	13	33
CX02-0101	CX02-0121	1 5/8	20	15	40
CX02-0102	CX02-0122	1 3/4	22	17	45
CX02-0103	CX02-0123	1 7/8	25	19	51
CX02-0104	CX02-0124	2	28	21	57
CX02-0105	CX02-0125	2 1/8	32	23	63
CX02-0106	CX02-0126	2 1/4	35	25	69

RATED CAPACITIES BASKET HITCH BASED ON D/d RATIO OF 25

RATED CAPACITIES BASED ON PIN DIAMETER NO LARGER THAN NATURAL EYE WIDTH OR LESS THAN THE NOMINAL SLING DIAMETER

RATED CAPACITIES BASED ON DESIGN FACTOR OF 5

HORIZONTAL SLING ANGLES LESS THAN 30 DEGREES SHALL NOT BE USED

Rated Capacities shown apply only to 6 x 19 and 6 x 37 classification wire rope.

WIRE ROPE SLINGS

CABLE LAID SLINGS/MECHANICAL SPLICE

2



**MECHANICAL TYPE SPLICE
RATED CAPACITIES IN TONS**

SLING BODY DIAMETER (INCHES)	CERTEX Cat. Ref. No.	CERTEX Cat. Ref. No.	SINGLE PART SLING			CERTEX Cat. Ref. No.	CERTEX Cat. Ref. No.	TWO LEG BRIDLE OR BASKET			
			VERTICAL	CHOKER	VERTICAL BASKET			30° DEGREE	45° DEGREE	60° DEGREE	
			7 x 7 x 7 CONSTRUCTION					7 x 7 x 7 CONSTRUCTION			
1/4	CX02-0127	—	0.50	0.34	1.0	CX02-0157	—	0.50	0.71	0.87	
3/8	CX02-0128	—	1.1	0.74	2.2	CX02-0158	—	1.1	1.5	1.9	
1/2	CX02-0129	—	1.9	1.3	3.7	CX02-0159	—	1.9	2.6	3.2	
5/8	CX02-0130	—	2.8	1.9	5.5	CX02-0160	—	2.8	3.9	4.8	
3/4	CX02-0131	—	3.8	2.6	7.6	CX02-0161	—	3.8	5.4	6.6	
7/8	CX02-0132	—	5.0	3.4	10.0	CX02-0162	—	5.0	7.1	8.7	
1	CX02-0133	—	6.4	4.4	13	CX02-0163	—	6.4	9.1	11	
7 x 7 x 19 CONSTRUCTION			7 x 7 x 19 CONSTRUCTION			7 x 7 x 19 CONSTRUCTION			7 x 7 x 19 CONSTRUCTION		
1/2	CX02-0134	—	1.9	1.3	3.8	CX02-0164	—	1.9	2.7	3.3	
5/8	CX02-0135	—	2.9	2.0	5.8	CX02-0165	—	2.9	4.1	5.0	
3/4	CX02-0136	—	4.1	2.8	8.1	CX02-0166	—	4.1	5.8	7.0	
7/8	CX02-0137	—	5.4	3.7	11	CX02-0167	—	5.4	7.6	9.4	
1	CX02-0138	—	6.9	4.7	14	CX02-0168	—	6.9	9.7	12	
1 1/8	CX02-0139	—	8.3	5.8	17	CX02-0169	—	8.3	12	14	
1 1/4	CX02-0140	—	9.9	7.0	20	CX02-0170	—	9.9	14	17	
7 x 6 x 19 OR 7 x 6 x 37 CONSTRUCTION			7 x 6 x 19 OR 7 x 6 x 37 CONSTRUCTION			7 x 6 x 19 OR 7 x 6 x 37 CONSTRUCTION			7 x 6 x 19 OR 7 x 6 x 37 CONSTRUCTION		
3/4	CX02-0141	CX02-0149	3.8	2.6	7.6	CX02-0171	CX02-0179	3.8	5.4	6.6	
7/8	CX02-0142	CX02-0150	5.0	3.4	10	CX02-0172	CX02-0180	5.0	7.1	8.7	
1	CX02-0143	CX02-0151	6.4	4.4	13	CX02-0173	CX02-0181	6.4	9.1	11	
1 1/8	CX02-0144	CX02-0152	7.7	5.4	15	CX02-0174	CX02-0182	7.7	11	13	
1 1/4	CX02-0145	CX02-0153	9.3	6.5	19	CX02-0175	CX02-0183	9.3	13	16	
1 3/8	CX02-0146	CX02-0154	11	7.7	22	CX02-0176	CX02-0184	11	15	19	
1 1/2	CX02-0147	CX02-0155	13	9.0	26	CX02-0177	CX02-0185	13	18	22	
1 5/8	CX02-0148	CX02-0156	15	10	30	CX02-0178	CX02-0186	15	21	26	

RATED CAPACITIES BASKET HITCH BASED ON D/d OF 10 OR GREATER

RATED CAPACITIES BASED ON PIN DIAMETER NO LARGER THAN NATURAL EYE WIDTH OR LESS THAN THE NOMINAL SLING DIAMETER.

RATED CAPACITIES BASED ON DESIGN FACTOR OF 5

HORIZONTAL SLING ANGLES LESS THAN 30 DEGREES SHALL NOT BE USED

WIRE ROPE SLINGS

4-PART BRAIDED SLINGS

2

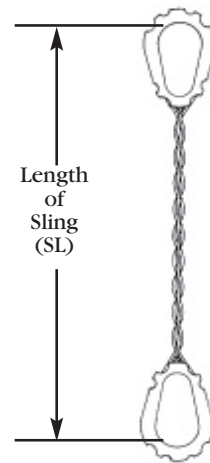
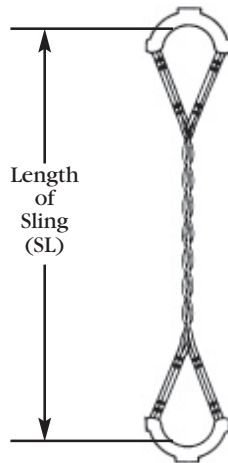
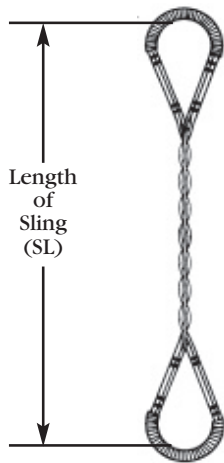

EXTRA IMPROVED PLOW STEEL IWRC



ROPE DIAMETER (INCHES)	CERTEX Cat. Ref. No.	SINGLE LEG		
		VERTICAL	CHOKER	VERTICAL BASKET
3/16	CX02-0187	1.1	0.94	2.2
1/4	CX02-0188	1.9	1.7	3.8
5/16	CX02-0189	2.9	2.6	5.9
3/8	CX02-0190	4.2	3.7	8.5
7/16	CX02-0191	5.7	5.0	11
1/2	CX02-0192	7.4	6.5	15
9/16	CX02-0193	9.4	8.2	19
5/8	CX02-0194	12	10	23
3/4	CX02-0195	16	14	33
7/8	CX02-0196	22	19	45
1	CX02-0197	29	25	58
1 1/8	CX02-0198	36	32	73
1 1/4	CX02-0199	45	39	89
1 3/8	CX02-0200	54	47	108
1 1/2	CX02-0201	64	56	127
1 5/8	CX02-0202	74	65	148
1 3/4	CX02-0203	86	75	171
1 7/8	CX02-0204	97	85	195
2	CX02-0205	111	97	222

RATED CAPACITIES BASKET HITCH BASED ON D/d RATIO OF 25 TIMES THE COMPONENT ROPE DIAMETER

RATED CAPACITY IN TONS

RATED CAPACITIES BASED ON PIN DIAMETER NO LARGER THAN NATURAL EYE WIDTH OR LESS THAN THE NOMINAL SLING DIAMETER

RATED CAPACITIES BASED ON DESIGN FACTOR OF 5

HORIZONTAL SLING ANGLES LESS THAN 30 DEGREES SHALL NOT BE USED

Rated Capacities shown apply only to 6x19, 7x19, and 6x37 classification wire rope.

WIRE ROPE SLINGS

6-PART BRAIDED SLINGS

2

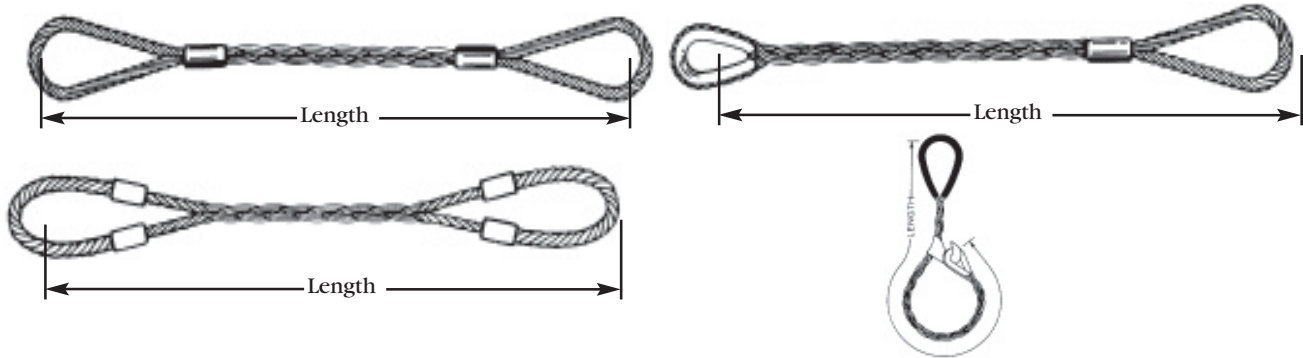

EXTRA IMPROVED PLOW STEEL IWRC
RATED CAPACITY IN TONS

ROPE DIAMETER (INCHES)	CERTEX Cat. Ref. No.	SINGLE LEG		
		VERTICAL	CHOKER	VERTICAL BASKET
		3/16	CX02-0206	1.6
1/4	CX02-0207	2.9	2.5	5.7
5/16	CX02-0208	4.4	3.9	8.8
3/8	CX02-0209	6.3	5.5	13
7/16	CX02-0210	8.6	7.5	17
1/2	CX02-0211	11	9.8	22
9/16	CX02-0212	14	12	28
5/8	CX02-0213	17	15	35
3/4	CX02-0214	25	22	49
7/8	CX02-0215	33	29	67
1	CX02-0216	43	38	87
1 1/8	CX02-0217	55	48	109
1 1/4	CX02-0218	67	59	134
1 3/8	CX02-0219	81	71	161
1 1/2	CX02-0220	96	84	191
1 5/8	CX02-0221	111	97	222
1 3/4	CX02-0222	128	112	257
1 7/8	CX02-0223	146	128	292
2	CX02-0224	166	145	332

RATED CAPACITIES BASKET HITCH BASED ON D/d RATIO OF 25 TIMES THE COMPONENT ROPE DIAMETER

RATED CAPACITIES BASED ON PIN DIAMETER NO LARGER THAN NATURAL EYE WIDTH OR LESS THAN THE NOMINAL SLING DIAMETER

RATED CAPACITIES BASED ON DESIGN FACTOR OF 5

HORIZONTAL SLING ANGLES LESS THAN 30 DEGREES SHALL NOT BE USED

Rated Capacities shown apply only to 6x19, 7x19, and 6x37 classification wire rope.

WIRE ROPE SLINGS

8-PART BRAIDED SLINGS



2

EXTRA IMPROVED PLOW STEEL IWRC
RATED CAPACITY IN TONS

ROPE DIAMETER (INCHES)	CERTEX Cat. Ref. No.	SINGLE LEG		
		VERTICAL	CHOKER	VERTICAL BASKET
1/8	CX02-0225	1.1	0.95	2.2
3/16	CX02-0226	2.2	1.9	4.3
1/4	CX02-0227	3.8	3.3	7.6
5/16	CX02-0228	5.5	4.8	11
3/8	CX02-0229	8	7	16
7/16	CX02-0230	11	10	23
1/2	CX02-0231	15	13	30
9/16	CX02-0232	19	16	38
5/8	CX02-0233	23	20	46
3/4	CX02-0234	33	29	66
7/8	CX02-0235	45	39	89
1	CX02-0236	58	51	116
1 1/8	CX02-0237	73	64	146
1 1/4	CX02-0238	89	78	179
1 3/8	CX02-0239	108	94	215
1 1/2	CX02-0240	127	111	255
1 5/8	CX02-0241	148	130	296
1 3/4	CX02-0242	171	150	343
1 7/8	CX02-0243	195	171	390
2	CX02-0244	222	194	443

RATED CAPACITIES BASKET HITCH BASED ON D/d RATIO OF 25 TIMES THE COMPONENT ROPE DIAMETER
 RATED CAPACITIES BASED ON PIN DIAMETER NO LARGER THAN NATURAL EYE WIDTH OR LESS THAN THE NOMINAL SLING DIAMETER
 RATED CAPACITIES BASED ON DESIGN FACTOR OF 5
 HORIZONTAL SLING ANGLES LESS THAN 30 DEGREES SHALL NOT BE USED
 Rated Capacities shown for 1/8" through 3/8" apply only to 7x19 galvanized wire rope.
 Rated Capacities shown for 3/8" apply only to 6x19, and 6x37 classification wire rope.

WIRE ROPE SLINGS

1-PART SLINGS/POURED SOCKETS

RATED CAPACITIES IN TONS

2

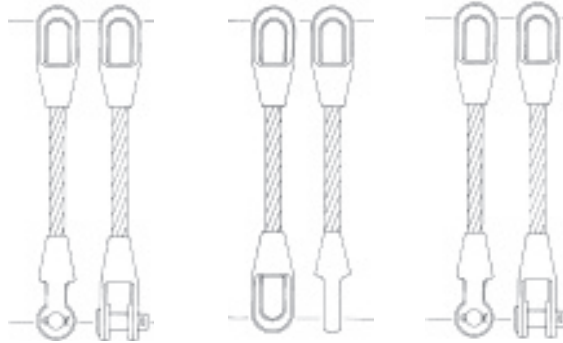

Open-Open Closed-Closed Open-Closed

ROPE DIAMETER (INCHES)	CERTEX Cat. Ref. No.	CERTEX Cat. Ref. No.	CERTEX Cat. Ref. No.	EXTRA IMPROVED PLOW STEEL IWRC
				VERTICAL
1/4	CX02-0392	CX02-0422	CX02-0392	0.68
5/16	CX02-0393	CX02-0423	CX02-0393	1.1
3/8	CX02-0394	CX02-0424	CX02-0394	1.5
7/16	CX02-0395	CX02-0425	CX02-0395	2.0
1/2	CX02-0396	CX02-0426	CX02-0396	2.7
9/16	CX02-0397	CX02-0427	CX02-0397	3.4
5/8	CX02-0398	CX02-0428	CX02-0398	4.1
3/4	CX02-0399	CX02-0429	CX02-0399	5.9
7/8	CX02-0400	CX02-0430	CX02-0400	8.0
1	CX02-0401	CX02-0431	CX02-0401	10
1 1/8	CX02-0402	CX02-0432	CX02-0402	13
1 1/4	CX02-0403	CX02-0433	CX02-0403	16
1 3/8	CX02-0404	CX02-0434	CX02-0404	19
1 1/2	CX02-0405	CX02-0435	CX02-0405	23
1 5/8	CX02-0406	CX02-0436	CX02-0406	26
1 3/4	CX02-0407	CX02-0437	CX02-0407	31
1 7/8	CX02-0408	CX02-0438	CX02-0408	35
2	CX02-0409	CX02-0439	CX02-0409	40
2 1/8	CX02-0410	CX02-0440	CX02-0410	44
2 1/4	CX02-0411	CX02-0441	CX02-0411	49
2 3/8	CX02-0412	CX02-0442	CX02-0412	55
2 1/2	CX02-0413	CX02-0443	CX02-0413	60
2 5/8	CX02-0414	CX02-0444	CX02-0414	66
2 3/4	CX02-0415	CX02-0445	CX02-0415	72
2 7/8	CX02-0416	CX02-0446	CX02-0416	78
3	CX02-0417	CX02-0447	CX02-0417	85
3 1/4	CX02-0418	CX02-0448	CX02-0418	98
3 1/2	CX02-0419	CX02-0449	CX02-0419	113
3 3/4	CX02-0420	CX02-0450	CX02-0420	128
4	CX02-0421	CX02-0451	CX02-0421	144

RATED CAPACITIES BASKET HITCH BASED ON D/d RATIO OF 25
 RATED CAPACITIES BASED ON PIN DIAMETER NO LARGER THAN NATURAL EYE WIDTH OR LESS THAN THE NOMINAL SLING DIAMETER
 RATED CAPACITIES BASED ON DESIGN FACTOR OF 5
 HORIZONTAL SLING ANGLES LESS THAN 30 DEGREES SHALL NOT BE USED
 Rated Capacities shown apply only to 6x19 and 6x37 classification wire rope.

WIRE ROPE SLINGS

1-PART SLINGS/SWAGE SOCKETS

Open-Open



SINGLE ROPE LEGS AND OPEN SWAGED SOCKETS

Open-Closed



SINGLE ROPE LEGS AND OPEN/CLOSED SWAGED SOCKETS

Closed-Closed



SINGLE ROPE LEGS AND CLOSED SWAGED SOCKETS
BOOM PENDENTS WITH SWAGED FITTINGS

2



Length of Pendant is measured as indicated on sketches.
Note: When ordering, customer should specify parallel or right angle (90°) socket pins.

Rated Capacity in Tons of 2,000 lbs
Rated Capacities Shown Apply Only To 6x19 and 6x36 Classification Wire Rope

ROPE DIA. (IN)	Open-Open				Open-Closed				Closed-Closed	
	FIBER CORE				IWRC					
	CERTEX Cat. Ref. No.	CERTEX Cat. Ref. No.	CERTEX Cat. Ref. No.	EIPS	CERTEX Cat. Ref. No.	CERTEX Cat. Ref. No.	CERTEX Cat. Ref. No.	EIPS	EEIPS	
1/4	CX02-0452	CX02-0496	CX02-0540	0.60	CX02-0474	CX02-0518	CX02-0562	0.68	0.74	
5/16	CX02-0453	CX02-0497	CX02-0541	0.94	CX02-0475	CX02-0519	CX02-0563	1.1	1.2	
3/8	CX02-0454	CX02-0498	CX02-0542	1.3	CX02-0476	CX02-0520	CX02-0564	1.5	1.7	
7/16	CX02-0455	CX02-0499	CX02-0543	1.8	CX02-0477	CX02-0521	CX02-0565	2.0	2.2	
1/2	CX02-0456	CX02-0500	CX02-0544	2.4	CX02-0478	CX02-0522	CX02-0566	2.7	2.9	
9/16	CX02-0457	CX02-0501	CX02-0545	3.0	CX02-0479	CX02-0523	CX02-0567	3.4	3.7	
5/8	CX02-0458	CX02-0502	CX02-0546	3.7	CX02-0480	CX02-0524	CX02-0568	4.1	4.5	
3/4	CX02-0459	CX02-0503	CX02-0547	5.2	CX02-0481	CX02-0525	CX02-0569	5.9	6.5	
7/8	CX02-0460	CX02-0504	CX02-0548	7.1	CX02-0482	CX02-0526	CX02-0570	8.0	8.8	
1	CX02-0461	CX02-0505	CX02-0549	9.2	CX02-0483	CX02-0527	CX02-0571	10	11	
1 1/8	CX02-0462	CX02-0506	CX02-0550	12	CX02-0484	CX02-0528	CX02-0572	13	14	
1 1/4	CX02-0463	CX02-0507	CX02-0551	14	CX02-0485	CX02-0529	CX02-0573	16	18	
1 3/8	CX02-0464	CX02-0508	CX02-0552	17	CX02-0486	CX02-0530	CX02-0574	19	21	
1 1/2	CX02-0465	CX02-0509	CX02-0553	20	CX02-0487	CX02-0531	CX02-0575	23	25	
1 5/8	CX02-0466	CX02-0510	CX02-0554	24	CX02-0488	CX02-0532	CX02-0576	26	29	
1 3/4	CX02-0467	CX02-0511	CX02-0555	27	CX02-0489	CX02-0533	CX02-0577	31	34	
1 7/8	CX02-0468	CX02-0512	CX02-0556	31	CX02-0490	CX02-0534	CX02-0578	35	38	
2	CX02-0469	CX02-0513	CX02-0557	35	CX02-0491	CX02-0535	CX02-0579	40	43	
2 1/8	CX02-0470	CX02-0514	CX02-0558	39	CX02-0492	CX02-0536	CX02-0580	44	49	
2 1/4	CX02-0471	CX02-0515	CX02-0559	44	CX02-0493	CX02-0537	CX02-0581	49	54	
2 3/8	CX02-0472	CX02-0516	CX02-0560	49	CX02-0494	CX02-0538	CX02-0582	55	60	
2 1/2	CX02-0473	CX02-0517	CX02-0561	54	CX02-0495	CX02-0539	CX02-0583	60	66	

* Values given apply when pendants are used as slings or sling assemblies. When used in a Boom suspension system, other values apply; consult rope manufacturer.