

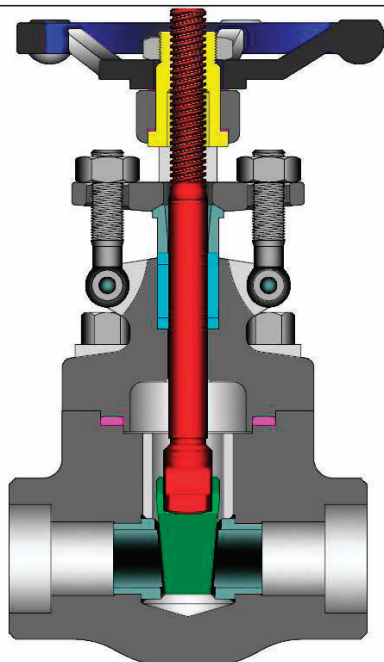

API 602 GATE VALVES
 FORGED CARBON, STAINLESS STEEL OR ALLOY STEEL
 1/4" TO 2" (6 TO 50 mm)
 ASME CLASSES 150 TO 2680



STANDARD MATERIALS (Other materials available)

PART	MATERIALS			
Body	A105	A182 F11	A182 F22	A182F316 (1)
Bonnet	A105	A182 F11	A182 F22	A182 F316
Wedge	SST 420			A182 F316
Seat Ring	SST 410 + Stellite 6 Faced			SST 316
Stem	A182 F6a			A182 F316
Stem Bushing	A 439 Ductile NI-Resist Gr. D2			
Gland Flange	A105			Series 300 SST
Eye Bolt	A193 Gr. B7	A193 Gr. B16		A193 Gr. B8M
Eye Bolt Nut	A194 Gr. 2H	A194 Gr. 7		A194 Gr.8M
Gland	SST 420			SST 316
Packing	Graphite			PTFE
Packing Washer / Packing Spacer	SST 410			SST 316
Gasket (2)	Spiral Wound SST with Graphite			Spiral Wound SST with PTFE
Hand Wheel	Malleable Iron or Steel			
Hand Wheel Nut	Malleable Iron or Steel			
Key	Steel			
Body / Bonnet Bolting (2)	A193 Gr. B7	A193 Gr. B16		A193 Gr. B8M
Identification Plate	Series 300 SST			

Class	Bore	Fig. No.
150	Standard	GA01
	Full	GAL1
300	Standard	GA03
	Full	GAL3
600	Standard	GA06
	Full	GAL6
800	Standard	GA08
	Full	GAL8
1500	Standard	GA15
	Full	GAL5
1680	Standard	GA16
2500	Standard	GA25
2690	Standard	GA26

- (1) Threaded and weld end valve bodies A182 F316L
- (2) Welded bonnet design also available.

NOTE: See page 43 for flow, safety and maintenance information.

DESIGN FEATURES:

- **Wedges** are accurately guided thru the entire stroke.
- **Standard trim** is stellite faced seat rings, 13% chrome wedge seat surfaces, and 13% chrome stem (API trim 8). Other trims available on request.
- **Seat faces** lapped for smooth finish and superior sealing.
- **Stems** are non-rotating with surface finish to maximize packing seal for low fugitive emissions.
- **Each** valve is shell, seat and back-seat pressure tested per industry standard API 598.
- **Gland** is two piece gland / gland flange design for optimal alignment and uniform packing compression.

- **End Flanges** have the following raised faces per ASME B16.5:
 Classes 150-300: 1/16" (2mm).
 Classes 600: 1/4" (7mm).
- **Weld ends** are available per ASME B16.25/B16.11 or per customer's specification.
- **Extended** body ends available on gate valves.
- **Other** available options as follows:
 -Alternate valve materials such as chrome and stainless steel alloys
 -Alternate trim materials
 -NACE service
 -Special cleaning for applications such as oxygen or chlorine
 -Other options available as specified.

Design Specifications

Item	Applicable Specification
Wall thickness	API 602
Pressure - temperature ratings	ASME B16.34
General valve design	API 602 & B16.34
End to End dimensions	ASME B16.10
Flange design	ASME B16.5
Thread design	ASME B1.20.1
Butt Weld design	ASME B16.25
Socket Weld design	ASME B16.11
Materials	ASTM

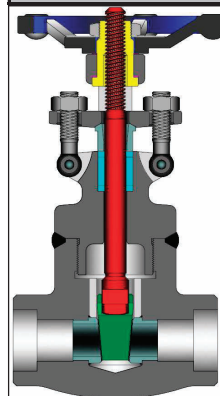

Welded Bonnet Design

GATE VALVE DIMENSIONS (CLASS 150—800).

SIZE	ASME 150				ASME 300				ASME 600			
	Bolted Bonnet				Bolted Bonnet				Bolted Bonnet			
	Standard Bore				Standard Bore				Standard Bore			
in	A	C	D	E	A	C	D	E	A	C	D	E
mm	FE				FE				FE			
½	4.25	6.0	0.50	3.9	5.50	6.0	0.50	3.9	6.50	6.0	0.50	3.9
13	108	153	13	100	140	153	13	100	165	153	13	100
¾	4.62	6.0	0.50	3.9	6.00	6.0	0.50	3.9	7.50	6.0	0.50	3.9
19	117	153	13	100	152	153	13	100	190	153	13	100
1	5.00	7.3	0.71	4.9	6.50	7.3	0.71	4.9	8.50	7.3	0.71	4.9
25	127	185	18	125	165	185	18	125	216	185	18	125
1¼	5.50	8.7	0.94	6.3	7.00	8.7	0.94	6.3	9.00	8.7	0.94	6.3
32	140	222	24	160	178	222	24	160	229	222	24	160
1½	6.50	9.4	1.14	6.3	7.50	9.4	1.14	6.3	9.50	9.4	1.14	6.3
38	165	240	29	160	190	240	29	160	241	240	29	160
2	7.00	11.0	1.46	7.1	8.50	11.0	1.46	7.1	11.50	11.0	1.46	7.1
50	178	279	37	180	216	279	37	180	292	279	37	180

SIZE	ASME 800															
	Bolted Bonnet								Welded Bonnet							
	Standard Bore				Full Bore				Standard Bore				Full Bore			
in	A	C	D	E	A	C	D	E	A	C	D	E	A	C	D	E
mm	WE				WE				WE				WE			
¼	3.11	5.9	0.31	3.9	-	-	-	-	3.11	6.2	0.31	3.9	-	-	-	-
6	79	149	8	100	-	-	-	-	79	157	8	100	-	-	-	-
¾	3.11	5.9	0.39	3.9	-	-	-	-	3.11	6.2	0.39	3.9	-	-	-	-
10	79	149	10	100	-	-	-	-	79	157	10	100	-	-	-	-
½	3.11	6.0	0.50	3.9	3.62	6.0	0.50	3.9	3.11	6.3	0.50	3.9	3.62	6.3	0.50	3.9
13	79	153	13	100	92	153	13	100	79	161	13	100	92	161	13	100
¾	3.62	6.0	0.50	3.9	4.37	7.3	0.71	4.9	3.62	6.3	0.50	3.9	4.37	7.5	0.71	4.9
19	92	153	13	100	111	185	18	125	92	161	13	100	111	190	18	125
1	4.37	7.3	0.71	4.9	4.72	8.7	0.94	6.3	4.37	7.5	0.71	4.9	4.72	8.7	0.94	6.3
25	111	185	18	125	120	222	24	160	111	190	18	125	120	220	24	160
1¼	4.72	8.7	1.14	6.3	4.72	9.4	1.14	6.3	4.72	8.7	1.14	6.3	4.72	9.4	1.14	6.3
32	120	222	29	160	120	240	29	160	120	220	29	160	120	240	29	160
1½	4.72	9.4	1.14	6.3	5.51	11.0	1.46	7.1	4.72	9.4	1.14	6.3	5.51	11.0	1.46	7.1
38	120	240	29	160	140	279	37	180	120	240	29	160	140	279	37	180
2	5.51	11.0	1.46	7.1	6.30	13.1	1.89	7.9	5.51	11.0	1.46	7.1	6.30	12.6	1.89	7.9
50	140	279	37	180	160	333	48	200	140	279	37	180	160	319	48	200

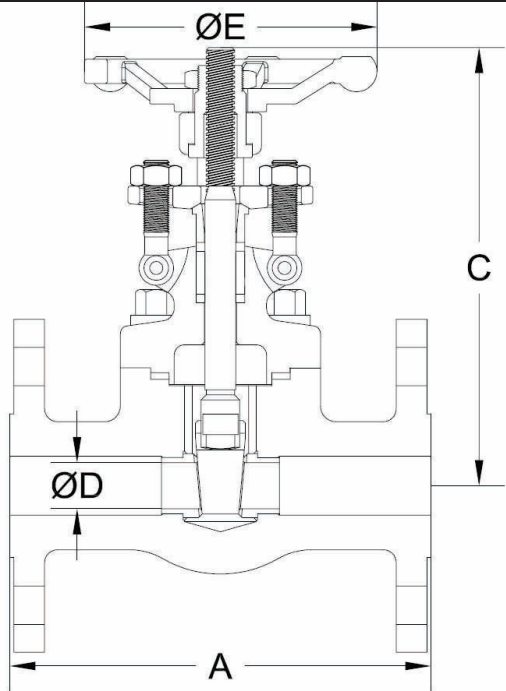

Bolted Bonnet Flanged Ends Design

**ADDITIONAL
MATERIALS AND
CLASSES
AVAILABLE UPON
REQUEST.**

WE = Socket Weld /
Threaded Ends
FE = Flanged ends
C = Center to top open

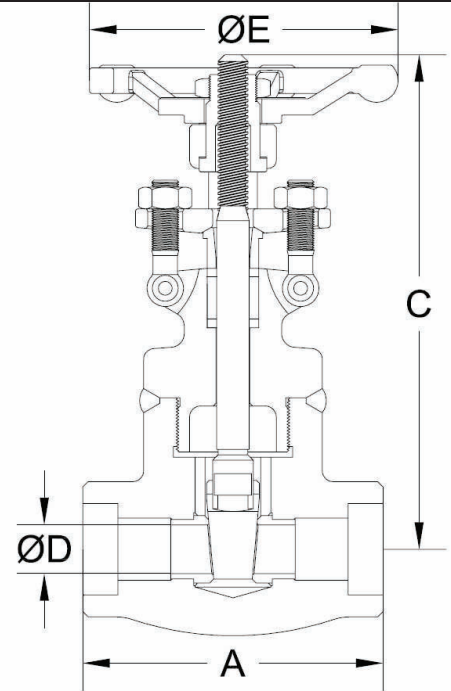

Welded Bonnet Socket Weld Ends Design

GATE VALVE DIMENSIONS (CLASS 1500—2680).

SIZE	ASME 1500 & 1690																
	Bolted Bonnet									Welded Bonnet							
	Standard Bore					Full Bore				Standard Bore				Full Bore			
in	A		C	D	E	A	C	D	E	A	C	D	E	A	C	D	E
mm	FE	WE				WE				WE							
¼	-	3.11	6.9	0.31	3.9	-	-	-	-	3.11	6.9	0.31	3.9	-	-	-	-
6	-	79	175	8	100	-	-	-	-	79	175	8	100	-	-	-	-
¾	-	3.62	7.0	0.50	3.9	-	-	-	-	3.62	6.9	0.50	3.9	-	-	-	-
10	-	92	178	13	100	-	-	-	-	92	175	13	100	-	-	-	-
½	8.50	3.62	7.1	0.50	4.9	4.37	7.1	0.50	4.9	3.62	7.1	0.50	4.9	4.37	7.1	0.50	4.9
13	216	92	181	13	125	111	181	13	125	92	181	13	125	111	181	13	125
¾	9.00	4.37	7.1	0.50	4.9	4.72	8.6	0.71	6.3	4.37	7.1	0.50	4.9	4.72	8.6	0.71	6.3
19	229	111	181	13	125	120	218	18	160	111	181	13	125	120	218	18	160
1	10.00	4.72	8.6	0.71	6.3	4.72	9.3	0.94	6.3	4.72	8.6	0.71	6.3	4.72	9.3	0.94	6.3
25	254	120	218	18	160	120	237	24	160	120	218	18	160	120	237	24	160
1¼	11.00	4.72	9.3	0.94	6.3	5.51	10.8	1.14	7.1	4.72	9.3	0.94	6.3	5.51	10.8	1.14	7.1
32	279	120	237	24	160	140	274	29	180	120	237	24	160	140	274	29	180
1½	12.00	5.51	10.8	1.14	7.1	6.30	12.6	1.46	7.9	5.51	10.8	1.14	7.1	6.30	12.6	1.46	7.9
38	305	140	274	29	180	160	319	37	200	140	274	29	180	160	319	37	200
2	14.50	6.30	12.6	1.46	7.9	9.1	13.6	1.89	7.9	6.30	12.6	1.46	7.9	9.1	13.6	1.89	7.9
50	368	160	319	37	200	230	345	48	200	160	319	37	200	230	345	48	200

SIZE	ASME 2500 & 2680												
	Bolted Bonnet					Welded Bonnet							
	Standard Bore					Standard Bore							
in	A		C	D	E	A	C	D	E	A	C	D	E
mm	WE	WE				WE				WE			
½	5.91	11.2	11.2	0.55	6.3	5.91	10.0	0.55	6.3	5.91	10.0	0.55	6.3
13	150	284	284	14	160	150	253	14	160	150	253	14	160
¾	5.91	11.2	11.2	0.55	6.3	5.91	10.0	0.55	6.3	5.91	10.0	0.55	6.3
19	150	284	284	14	160	150	253	14	160	150	253	14	160
1	6.69	12.9	12.9	0.75	7.9	6.69	11.5	0.75	7.9	6.69	11.5	0.75	7.9
25	170	327	327	19	200	170	291	19	200	170	291	19	200
1¼	7.87	14.7	14.7	1.00	9.8	7.87	13.3	1.00	9.8	7.87	13.3	1.00	9.8
32	200	374	374	25	250	200	339	25	250	200	339	25	250
1½	7.87	14.8	14.8	1.10	9.8	7.87	13.5	1.10	9.8	7.87	13.5	1.10	9.8
38	200	377	377	28	250	200	342	28	250	200	342	28	250
2	9.84	17.1	17.1	1.38	11.8	9.84	15.7	1.38	11.8	9.84	15.7	1.38	11.8
50	250	434	434	35	300	250	398	35	300	250	398	35	300

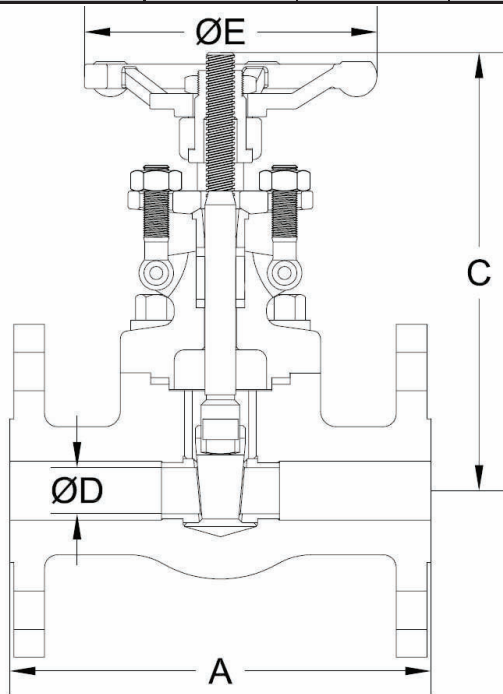

Bolted Bonnet Flanged Ends Design

**ADDITIONAL
MATERIALS AND
CLASSES
AVAILABLE UPON
REQUEST.**

**WE = Socket Weld /
Threaded Ends**
FE = Flanged Ends

C = Center to top open

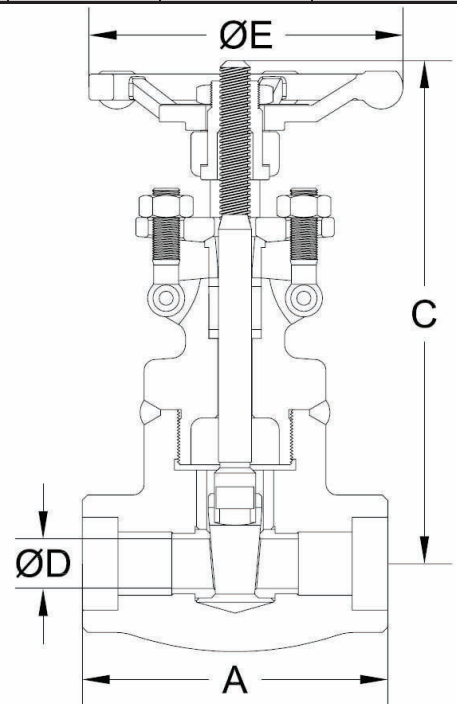

Welded Bonnet Socket Weld Ends Design



API 602 GATE VALVES
 FORGED CARBON , STAINLESS STEEL OR ALLOY STEEL
 ¼” TO 2” (6 TO 50 mm)
 ASME CLASSES 150 TO 2680

SIZE	ASME 150			ASME 300			ASME 600			ASME 800											
	Bolted Bonnet			Bolted Bonnet			Bolted Bonnet			Bolted Bonnet						Welded Bonnet					
	Standard Bore			Standard Bore			Standard Bore			Standard Bore			Full Bore			Standard Bore			Full Bore		
in	WT	LB	C _v	WT	LB	C _v	WT	LB	C _v	WT	LB	C _v	WT	LB	C _v	WT	LB	C _v	WT	LB	C _v
mm	FE	KG		FE	KG		FE	KG		WE	KG		WE	KG		WE	KG		WE	KG	
¼	-	-	-	-	-	-	-	-	-	4.2	5	-	-	3.7	5	-	-	-	-		
6	-	-	-	-	-	-	-	-	-	1.9	-	-	-	1.7	-	-	-	-	-		
¾	-	-	-	-	-	-	-	-	-	4.2	8	-	-	3.7	8	-	-	-	-		
10	-	-	-	-	-	-	-	-	-	1.9	-	-	-	1.7	-	-	-	-	-		
½	6.6	13	-	7.9	13	-	9.3	13	-	4.4	13	-	7.3	13	-	4.0	13	-	7.1	13	
13	3.0	-	-	3.6	-	-	4.2	-	-	2.0	-	-	3.3	-	-	1.8	-	-	3.2	-	
¾	7.7	13	-	10.8	13	-	12.8	13	-	4.9	13	-	8.4	25	-	4.4	13	-	8.2	25	
19	3.5	-	-	4.9	-	-	5.8	-	-	2.2	-	-	3.8	-	-	2.0	-	-	3.7	-	
1	12.1	30	-	15.4	30	-	19.4	30	-	7.9	30	-	12.8	45	-	7.5	30	-	12.6	45	
25	5.5	-	-	7.0	-	-	8.8	-	-	3.6	-	-	5.8	-	-	3.4	-	-	5.7	-	
1¼	15.0	70	-	20.7	70	-	26.7	70	-	13.7	70	-	14.8	70	-	11.7	70	-	14.6	70	
32	6.8	-	-	9.4	-	-	12.1	-	-	6.2	-	-	6.7	-	-	5.3	-	-	6.6	-	
1½	22.9	70	-	29.3	70	-	34.4	70	-	13.7	70	-	22.7	110	-	13.2	70	-	22.5	110	
38	10.4	-	-	13.3	-	-	15.6	-	-	6.2	-	-	10.3	-	-	6.0	-	-	10.2	-	
2	31.7	120	-	39.7	80	-	43.0	120	-	21.4	120	-	33.5	220	-	20.9	120	-	33.3	220	
50	14.4	-	-	18.0	-	-	19.5	-	-	9.7	-	-	15.2	-	-	9.5	-	-	15.1	-	

SIZE	ASME 1500 & 1690												ASME 2500 & 2680							
	Bolted Bonnet						Welded Bonnet						Bolted Bonnet			Welded Bonnet				
	Standard Bore			Full Bore			Standard Bore			Full Bore			Standard Bore			Standard Bore				
in	WT	LB	WT	LB	C _v	WT	LB	C _v	WT	LB	C _v	WT	LB	C _v	WT	LB	C _v	WT	LB	C _v
mm	FE	KG	WE	KG		WE	KG		WE	KG		WE	KG		WE	KG		WE	KG	
¼	-	-	6.6	-	5	-	-	-	6.2	5	-	-	-	-	-	-	-	-	-	-
6	-	-	3.0	-	-	-	-	-	2.8	-	-	-	-	-	-	-	-	-	-	-
¾	-	-	7.1	13	-	-	-	-	6.6	13	-	-	-	-	-	-	-	-	-	-
10	-	-	3.2	-	-	-	-	-	3.0	-	-	-	-	-	-	-	-	-	-	-
½	15.9	-	7.7	13	-	9.5	13	-	7.3	13	-	9.3	13	-	21.6	20	-	15.0	20	-
13	7.2	-	3.5	-	-	4.3	-	-	3.3	-	-	4.2	-	-	9.8	-	-	6.8	-	-
¾	25.4	-	8.8	13	-	13.9	25	-	8.2	13	-	13.7	25	-	22.0	20	-	15.4	20	-
19	11.5	-	4.0	-	-	6.3	-	-	3.7	-	-	6.2	-	-	10.0	-	-	7.0	-	-
1	34.4	-	13.2	25	-	16.1	45	-	12.6	25	-	15.9	45	-	49.6	25	-	22.0	25	-
25	15.6	-	6.0	-	-	7.3	-	-	5.7	-	-	7.2	-	-	22.5	-	-	10.0	-	-
1¼	35.7	-	15.4	45	-	24.7	70	-	14.8	45	-	24.5	70	-	69.9	55	-	43.4	55	-
32	16.2	-	7.0	-	-	11.2	-	-	6.7	-	-	11.1	-	-	31.7	-	-	19.7	-	-
1½	49.8	-	23.8	70	-	35.1	110	-	23.1	70	-	34.8	110	-	70.5	70	-	57.3	70	-
38	22.6	-	10.8	-	-	15.9	-	-	10.5	-	-	15.8	-	-	32.0	-	-	26.0	-	-
2	62.2	-	34.2	120	-	36.4	220	-	33.5	120	-	36.2	220	-	83.8	120	-	69.9	120	-
50	28.2	-	15.5	-	-	16.5	-	-	15.2	-	-	16.4	-	-	38.0	-	-	31.7	-	-

FE = Flanged Ends
WE = Socket Weld / Threaded Ends

WT = Weight
C_v = Flow Coefficient