

THERMOSTATIC MIXING VALVE

ECO-MIX™

MODEL 270-LF

LEAD FREE THERMOSTATIC POINT OF USE MIXING VALVE

MODEL 1/2" inlets, 1/2" outlet, (MIPS connections)

MATERIALS:

- Lead Free Bronze body
- Locked temperature adjustment cap (vandal resistant)
- Copper encapsulated thermostat assembly with polymer thermoplastic shuttle
- Stainless steel springs
- Buna-N O-rings
- Integral check valves on hot and cold inlets

PRESSURE-TEMPERATURE:

- Minimum Flow: 0.25 GPM (0.95 l/Min)*
- Maximum Pressure: 125 PSI (8.6 BAR)
- Maximum Hot Water temperature: 200°F- (93°C)
- Approach Temperature 5°F (2.8°C) above set point.
- Temperature adjustment range, 90-140°F (32-60°C) **

OPTIONS:

- ___ SUFFIX BRKT- Mounting bracket
- ___ SUFFIX BV- Inlet ball valves (shipped loose)
- ___ SUFFIX SW- Sweat connections
- ___ SUFFIX CP- Chrome plated

ASSE 1017, 1070 CERTIFIED



This product is certified to meet Low Lead requirements of wetted surface area containing less than 0.25% lead by weight

****NOTE:** For temperatures outside of this valve's stated range, please see our line of bi-metal valves.

* 0.25 GPM minimum flow certified to ASSE 1070

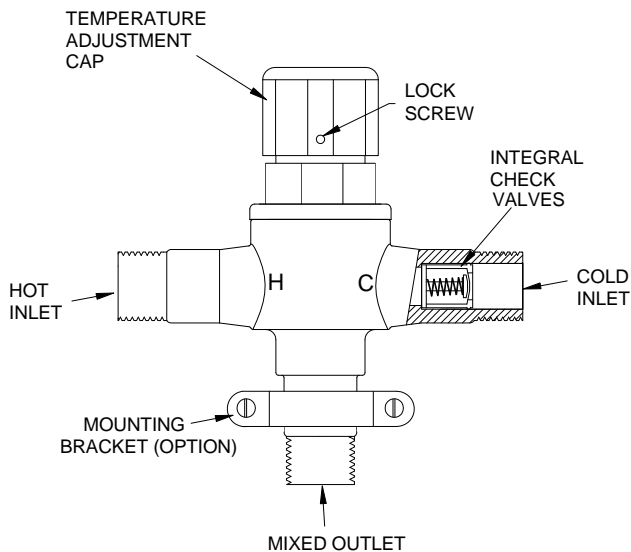
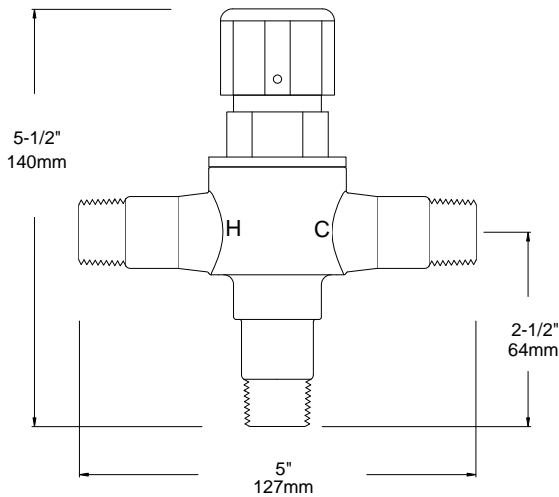

PRESSURE DROP						
5	10	20	30	40	50	PSI
.35	.70	1.4	2.1	2.8	3.4	BAR
3.5	5.5	7.5	9.5	10.5	12	GPM
13	21	28	36	40	45	l/min

Engineer's Approval	Job # _____
	Arch/Eng. _____
	Contractor _____



1360 Elmwood Avenue, Cranston, RI 02910 USA
 Phone: 401.461.1200 Fax: 401.941.5310
 Email: info@leonardvalve.com
 Web Site: <http://www.leonardvalve.com>



170-LF



270-LF

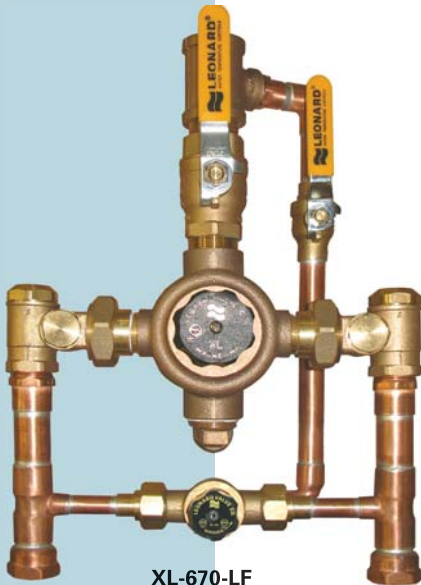

XL-670-LF

TEMPERATURE LIMITING VALVES

MODEL 170-LF Single outlet mixing valve for lavatory, sink

MODEL 270-LF, 370-LF, XL-670-LF Single or multiple outlet mixing valves for lavatories, sinks or for small hot water heater applications

Copper encapsulated wax thermostat

Locking temperature setting

Integral check valves on hot and cold inlets

All models ASSE 1070 Listed and 3rd Party certified as Lead Free

ASSE Standard 1017 Listed (270, 370)





170-LF, 270-LF, 370-LF, XL-670-LF Thermostatic Water Mixing Valves

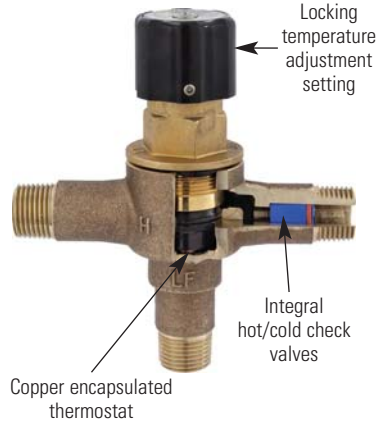

Model 170-LF, 270-LF, 370-LF and XL-670-LF valves are furnished with:

- Highly responsive copper encapsulated thermostat assembly
- Locking temperature adjustment (tamper-resistant)
- Bronze body; brass, stainless steel and engineered polymer internal components
- Integral check valves on hot and cold inlets
- Approach temperature 5°F (2.8°C) above set point
- Minimum flow rate: 370-LF only, 0.5 GPM (1.9 l/min); 170-LF and 270-LF, 0.25 GPM (0.95 l/min); XL-670-LF, 2.5 GPM (9.5 l/min)
- Maximum hot water supply temperature: 200°F (93°C)
- Maximum supply pressure: 125 PSI

Selection/Specification Guide

MODEL # – OPTION#

MODEL

170-LF*	3/8" Compression fittings
270-LF**	1/2" MIPS
370-LF**	3/4" MIPS
XL-670-LF*	1" threaded inlets, 1-1/4" threaded outlet

OPTIONS

BP	Cold water bypass port (170-LF only)
BRKT	Mounting bracket
BV	2 Shutoff valves (ball valves) (270-LF, 370-LF only)
SW	Sweat connections (270-LF, 370-LF only)

BWE-REC	Steel Baked Enamel Recessed Cabinet
STSTL-REC	Stainless Steel Recessed Cabinet
BWE-EXP	Steel Baked Enamel Exposed Cabinet
STSTL-EXP	Stainless Steel Exposed Cabinet

Note: Model 170-LF is designed for one fixture only!

* ASSE Standard 1070 Listed

** ASSE Standards 1070 and 1017 Listed

All models are 3rd Party certified as Lead Free



170-LF-BP



270-LF-BRKT



270-LF-BV



370-LF



XL-670-LF

Flow Capacities

MODEL	IN	OUT	MINIMUM FLOW GPM	PRESSURE DROP											PSI
				5	10	15	20	25	30	35	40	45	50		
170-LF*	3/8" (9.5mm)	3/8" (9.5mm)	0.25	1.7	2.3	2.7	3.0	3.2	3.6	4.0	4.4	4.7	5.0	GPM	
			0.95	6.4	8.7	10.2	11.4	12.1	13.6	15.1	16.5	17.8	18.9	L/MIN	
270-LF**	1/2" (12.7mm)	1/2" (12.7mm)	0.25	3.5	5.5	6.5	7.5	8.5	9.5	10.0	10.5	11.5	12.0	GPM	
			0.95	13.2	20.8	24.6	28.4	32.2	36.0	37.9	39.7	43.5	45.4	L/MIN	
370-LF**	3/4" (19.1mm)	3/4" (19.1mm)	0.5	4.0	6.0	7.0	8.0	9.0	10.0	10.5	11.5	12.5	13.0	GPM	
			1.9	15.1	22.7	26.5	30.3	34.1	37.9	39.7	43.5	47.3	49.2	L/MIN	
XL-670-LF*	1" (25.4mm)	1 1/4" (31.6mm)	2.5	5	10	20	35	39	41	48	55	59	62	GPM	
			9.5	19	38	76	132	148	155	182	208	223	235	L/MIN	

* ASSE STANDARD 1070 LISTED
 ** ASSE STANDARDS 1017 & 1070 LISTED
 ALL MODELS ARE 3RD PARTY CERTIFIED AS LEAD FREE

MAXIMUM FLOW CAPACITY

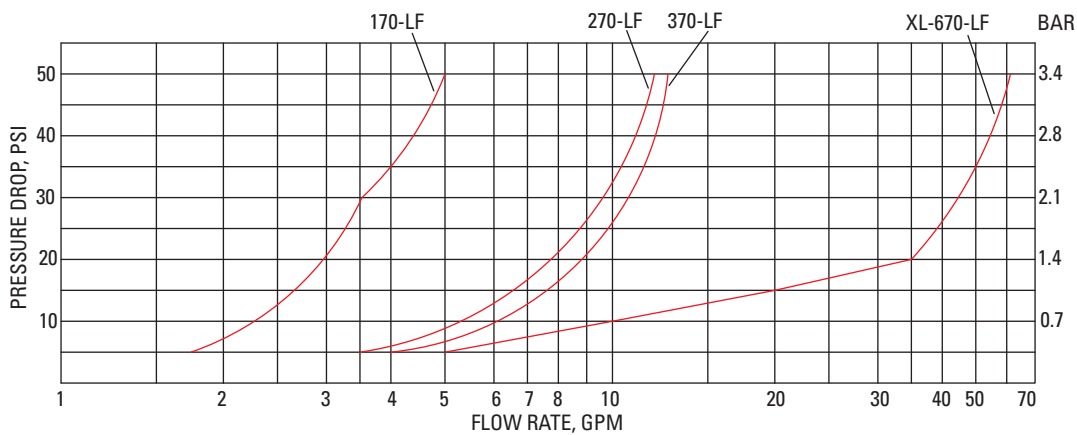

CAUTION! All thermostatic water mixing valves have limitations. They will not provide the desired accuracy outside of their flow capacity range. Consult the above chart and graph and make certain the required flow rates are within the limits shown.

Note: Flow rates will vary depending on existing field conditions. Leonard Valve Company always recommends using CASPAK® sizing software for proper valve sizing and model number applications.

Specification

Leonard Model 170-LF Thermostatic Mixing Valves for Single Outlet Application, bronze body, copper encapsulated thermostat, brass and engineered polymer internals, stainless steel spring, locking temperature adjustment knob (tamper-resistant), integral check valves on inlets, compression connections, rough bronze finish.

Leonard Model 170-LF-BP with cold water bypass port

Leonard Model 270-LF, 370-LF, XL-670-LF Thermostatic Mixing Valves, bronze body, copper encapsulated thermostat, brass and engineered polymer internals, stainless steel spring, locking temperature adjustment knob (tamper-resistant), integral check valves on inlets, MIPS connections, rough bronze finish.



270-LF



370-LF

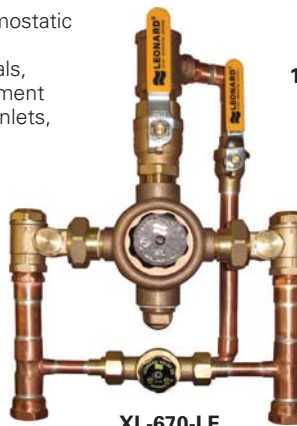

XL-670-LF



170-LF



170-LF-BP

Leonard Model _____ - _____ Thermostatic Mixing Valve Cabinet Assembly. Valve with bronze body, copper encapsulated thermostat, brass and engineered polymer internals, stainless steel spring, locking temperature adjustment knob (tamper-resistant), integral check valves on inlets, IPS or sweat connections, mounting bracket. Cabinet shall be exposed (recessed) type, stainless steel (steel baked enamel) construction, hinged left hand door with cylinder lock, punched for side inlets, bottom outlet.

Unit shall be ASSE 1070 Listed and 3rd Party certified as Lead Free

Required Piping – Point of Use Applications

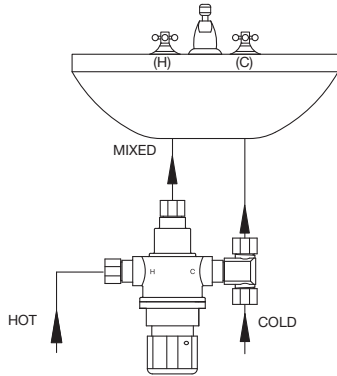

Two-Handle Faucet

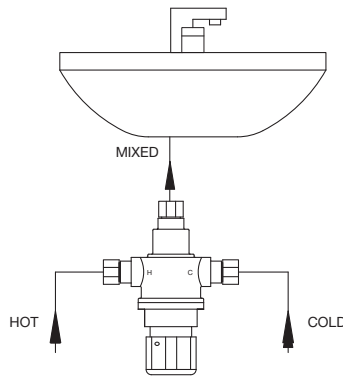

Sensor Faucet
(Single Supply)

Required Piping – Hot Water Heater Applications

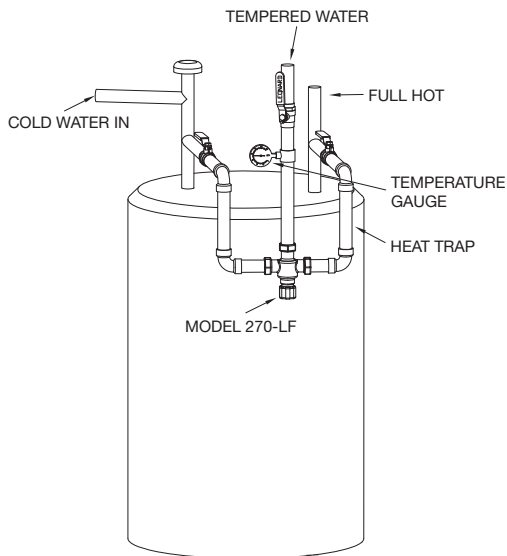

Note: All specifications are subject to change without notice!



1360 Elmwood Avenue
Cranston, RI 02910 USA
800.222.1208
t 401.461.1200
f 401.941.5310
info@leonardvalve.com
www.leonardvalve.com

LV-122 06/13
©2013 Leonard Valve Company
Printed in the U.S.A.