



INSTALLATION, OPERATION & MAINTENANCE INSTRUCTIONS

1455 Kleppe Lane ♦ Sparks, NV 89431-6467 ♦ (775) 359-4712 ♦ Fax (775) 359-7424
E-mail: haws@hawsco.com ♦ website: www.hawsco.com

No. 0002075200 (2)

Model 5010SS

NOTE TO INSTALLER: Please leave this information with the Maintenance Department.

LIMITED WARRANTY

HAWS warrants that this specific product is guaranteed against defective material or poor workmanship for a period of **one year from date of shipment**. HAWS liability under this warranty shall be discharged by furnishing without charge F.O.B. HAWS Factory any goods, or part thereof, which shall appear to the Company upon inspection to be of defective material or not of first class workmanship, provided that claim is made in writing to Haws within a reasonable period after receipt of the product. Where claims for defects are made, the defective part or parts shall be delivered to the Company, prepaid, for inspection. HAWS will not be liable for the cost of repairs, alterations or replacements, or for any expense connected therewith made by the owner or his agents, except upon written authority from HAWS, Sparks, Nevada. HAWS will not be liable for any damages caused by defective materials or poor workmanship, except for replacements, as provided above. Buyer agrees that HAWS shall not be liable for general, special, or consequential damages claimed to arise under the contract of sale. The drinking fountain manufactured by HAWS is warranted to function if installation and maintenance instructions provided are adhered to. The units also must be used for the purpose for which they were intended.

**NO OTHER WARRANTIES EXPRESSED OR IMPLIED ARE AUTHORIZED,
PROVIDED OR GIVEN BY HAWS.**

**SHOULD YOU EXPERIENCE DIFFICULTY WITH THE INSTALLATION OF THIS
MODEL PLEASE CALL:**

TECHNICAL SUPPORT: 1-800-766-5612

FOR CUSTOMER SERVICE: 1-888-640-4297

OPERATION & MAINTENANCE INSTRUCTIONS

FLOW ADJUSTMENT:

Step 1: Gain access to flow adjustment screw by removing cover nut and button (see Installation Drawing).

Step 2: Adjust flow with screwdriver: clockwise for more flow, counterclockwise for less.

Step 3: If desired flow is not obtained, clean screen located at base of valve body (see Installation drawing page 4 of 4) and make sure screwdriver stop (not supplied) is fully opened. **Note:** To remove head and gain access to screen (for example, when used with electric water cooler), keep the inlet nipple from turning by holding it with locking pliers inside the fountain, beneath the basin.

Step 4: Replace button and cover nut.

CARTRIDGE ASSEMBLY REPLACEMENT:

Note: Replacement cartridge, screen, and gasket is available as P/N VRK5010. To gain access to cartridge assembly with gasket:

Step 1: Remove cover nut and button, then remove retaining nut using universal spanner wrench (Haws part number 0006983506 – not supplied).

Step 2: Pull cartridge assembly out.

Step 3: Insert new cartridge with gasket.

- Do not remove gasket that comes with new cartridge.
- Ensure that the gasket on the new cartridge is very clean with no debris.
- Make sure there is no foreign matter in the valve body before inserting the new cartridge assembly with gasket into the valve body.
- When inserting cartridge assembly with gasket, align inlet and outlet ports on cartridge, with holes in the valve body.
- Ensure the cartridge ports are properly aligned and cartridge has bottomed out by turning slightly into place.

Step 4: Install retaining nut until it makes contact with the cartridge, then tighten 1 1/4 turn farther.

Step 5: Replace button and cover nut.

CAUTION: When replacing cartridge assembly, damage can occur if not properly re-installed. Read instructions carefully.

OPTIONAL PB8C (COPPER PLATED PUSH BUTTON & NUT) CLEANING & CARE:

If evidence of copper oxidation arises, simply rub surface with a soft rag and salt & water mixture. Soft cleaning solutions may also be used on the copper button surface.

© 2021 Haws® Corporation – All Rights Reserved

HAWS® and other trademarks used in these materials are the exclusive property of Haws Corporation.

PART BREAKDOWN

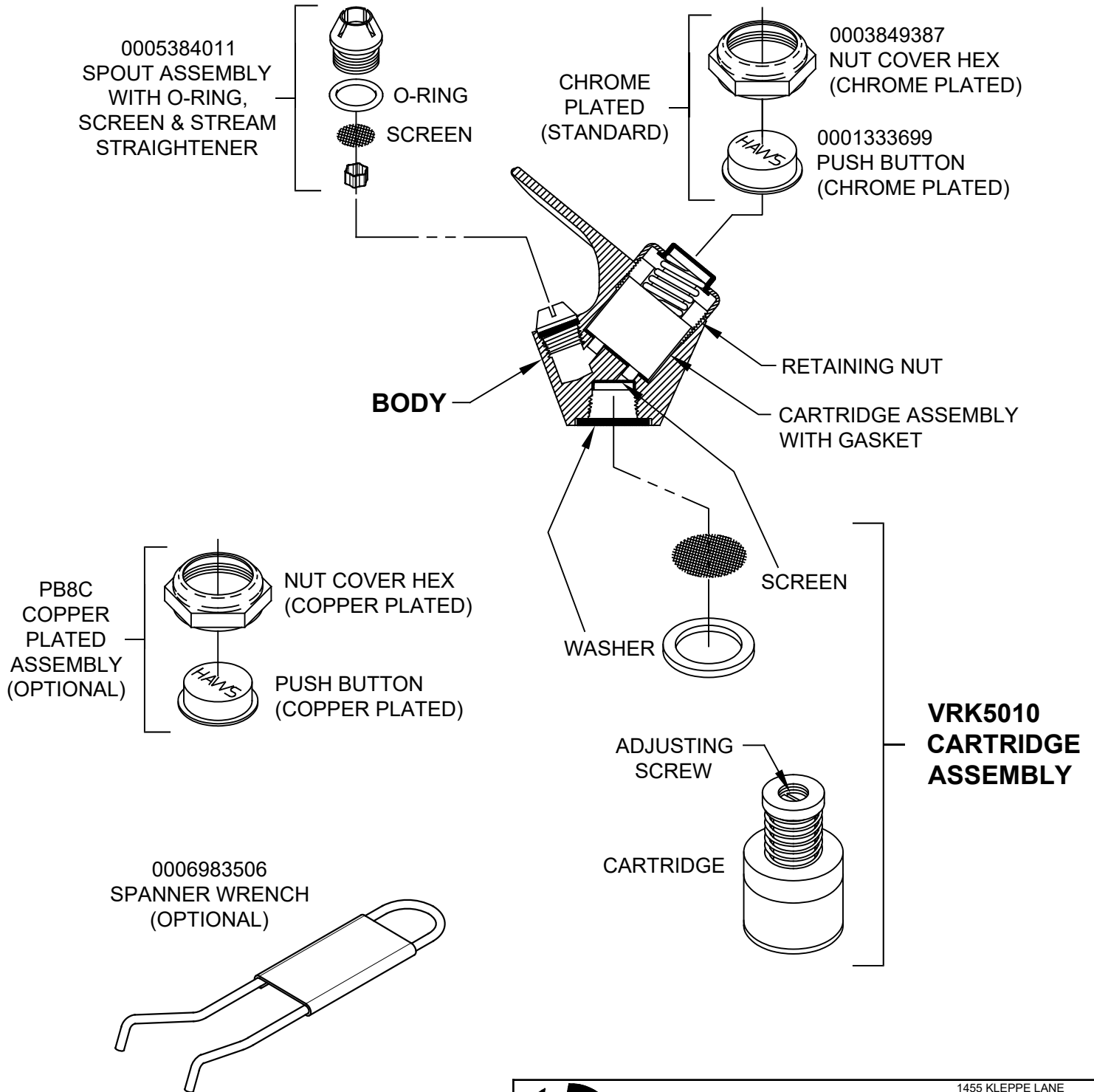

WHEN ORDERING PARTS PLEASE SPECIFY MODEL NUMBER.

 Haws [®]		1455 KLEPPE LANE SPARKS, NEVADA 89431 (775) 359-4712 FAX (755) 359-7424 E-MAIL: HAWS@HAWS.CO.COM WEBSITE: WWW.HAWS.CO.COM	
		ECN NO. 4215 ECN: 5664 DRAWN: BW APPROVED: FV	REVISED PER: JL DATE: 01/14/09 DATE: 03/02/21

NOTES:

TO ADJUST FLOW:

1. REMOVE HEX NUT COVER AND PUSH BUTTON COVER.
2. ADJUST WITH SCREWDRIVER: CLOCKWISE TO INCREASE FLOW & COUNTER-CLOCKWISE TO DECREASE FLOW.
3. IF DESIRED FLOW IS NOT OBTAINED, CLEAN SCREEN AT INLET (SEE 5010SS OPERATION AND MAINTENANCE MANUAL FOR ACCESS INSTRUCTIONS).
4. REPLACE PUSH BUTTON COVER AND HEX NUT COVER.

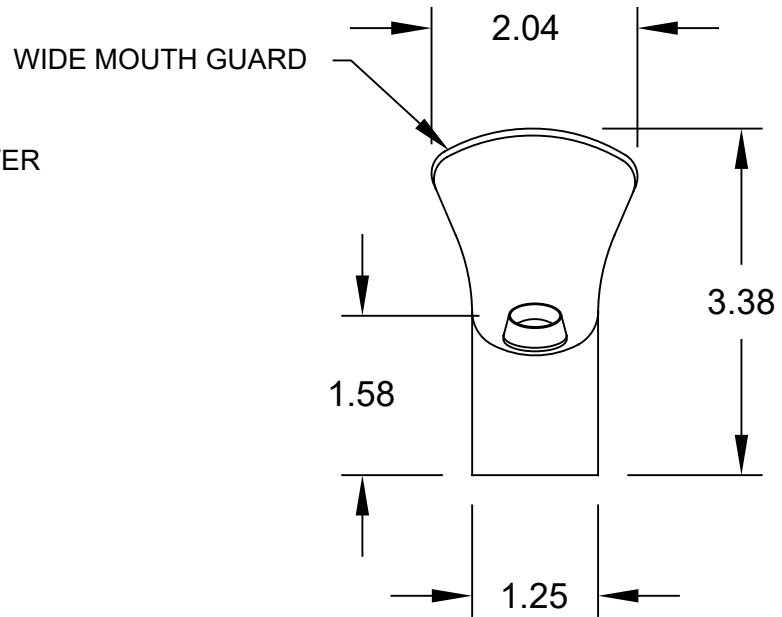
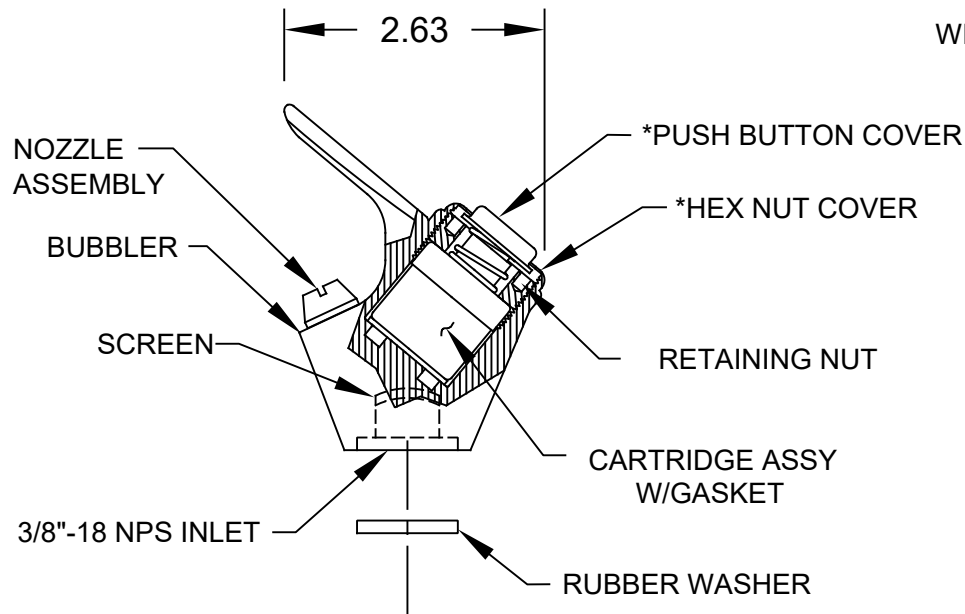
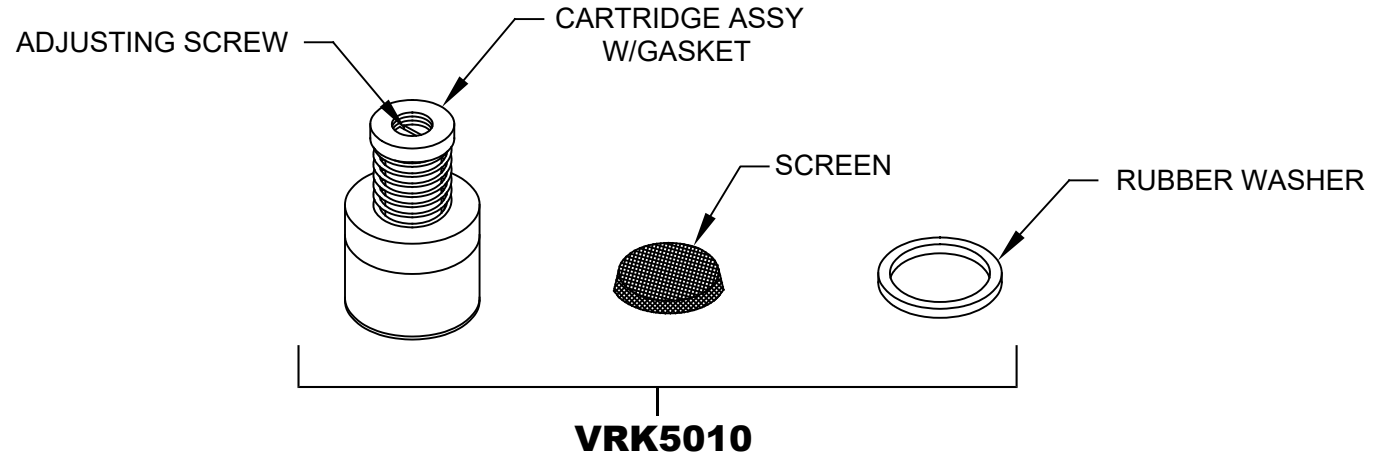

*CHROME PLATED PUSH BUTTON COVER & NUT ARE STANDARD ON 5010SS. COPPER PLATED OPTION IS AVAILABLE AS MODEL PB8C.

		1455 KLEPPE LANE SPARKS, NEVADA 89431 (775) 359-4712 FAX (755) 359-7424 E-MAIL: HAWS@HAWSO.COM WEBSITE: WWW.HAWSO.COM	
		ECN NO. 4215 DRAWN: SLS APPROVED: FV	REVISED PER: JL ECN: 5664 DATE: 01/14/99 DATE: 03/02/21
SCALE: 1:1		DRAWING TYPE: INSTALLATION	SIZE: A SHEET 1 OF 1