

Building connections that last™



ABZ 400 Series

ABZolute Double Offset High Performance Butterfly Valves Datasheet



ABZolute Double Offset High Performance Butterfly Valves

ABZ 400 Series

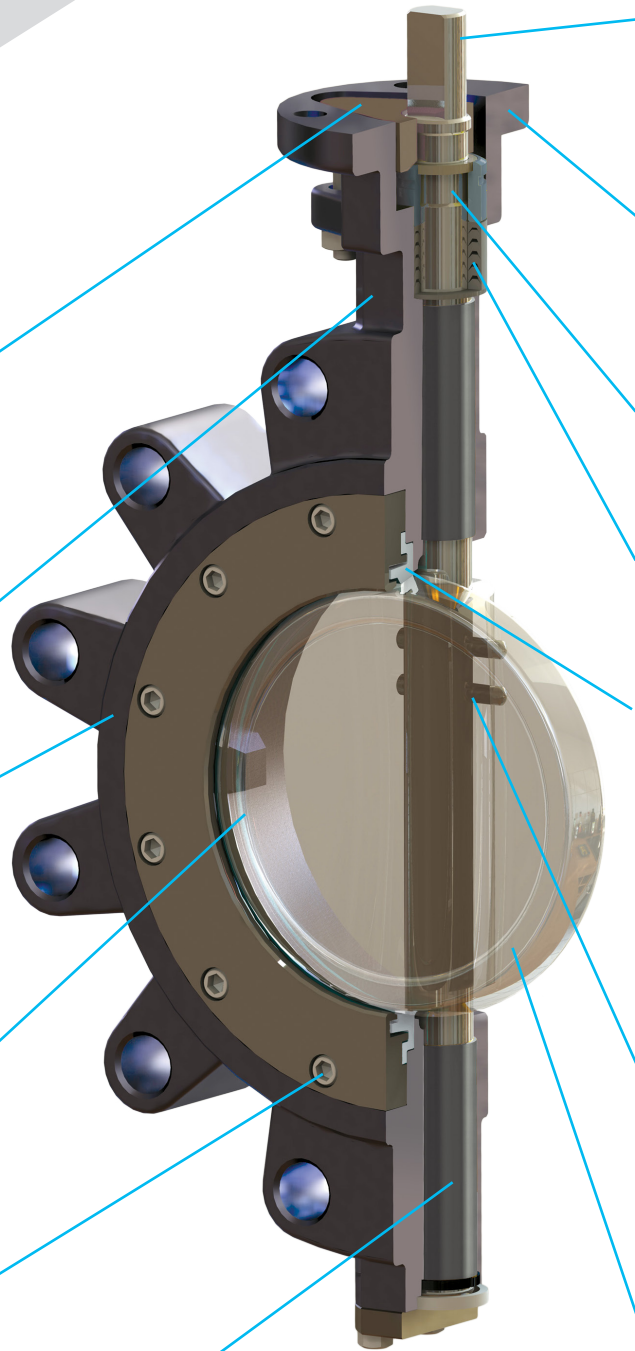

Underneath Drawn Gland Packing

Allows for direct mounting of actuation and ease of user adjustment. A rocker design gland flange and packing gland are utilized to insure 360 degree packing adjustment.

Extended Neck

Allows for two inches of pipe insulation.

Body

High quality one-piece casting provides consistent uniformity. Body is available in Wafer, Lug, Double Flanged and Butt Welded. Body materials include WCB, CF8M, Duplex 2205, Monel, SMO 255 and many others.

Integrally Cast Disc Position Stop

Machined position stop in the body locates the disc in the seat to achieve maximum sealing and seat life.

Seat Retainer Plate

Constructed of the same material as the body, this robust multi-bolted seat retainer contains and supports the seat in both Bi-Directional Flow and Double Dead End Service for all soft seated valves.

Bearings

Made of Graphite impregnated or reinforced PTFE impregnated 316 Stainless Steel to ensure long service life.

Stem

Manufactured as a standard of 17/4 PH Stainless Steel to provide maximum strength and stability for high torque applications. Other materials available upon request.

Mounting Flange

Designed to direct mount actuation for ease of installation and cost savings. No bracket is needed for manual actuation or for automatic automation up to 20 inches.

Blowout Proof Stem

Blowout proof stem retention system is designed per API 609 standards and is located above the packing area.

Packing

PTFE is a cup and cone system. Graphite is die-formed rings for positive seals.

Seat

An advanced free floating, pressure assisted, solid seat design provides an interference and pressure assisted seal. This achieves a positive seal under both low and high pressure requirements. The 400 series seat does not rely on secondary located components such as O-Rings, springs, wire or metal bands to hold the seat in place. This allows for a longer service life with less maintenance.

Disc Taper Pins

Pins are offset from the center of the stem which places them in compression rather than in shear. This gives them a yield point greater than the stem itself. Pins are welded in place after final assembly and testing.

Disc

Standard construction is 316 stainless steel with numerous alloys available. ABZolute 400 Series disc is engineered for a quick release from the seat which reduces torque and seat wear.



ABZolute Double Offset High Performance Butterfly Valves

ABZ 400 Series

Soft Seat Design

- Solid seat, free floating, pressure assisted seal
- No additional parts are required to maintain positive seal
- ABZolute 400 series soft seated valves are rated full ANSI pressure
- Seat and seat retainers are designed for Bi-Directional and Double Dead End Service
- Class VI Bi-Directional shut off

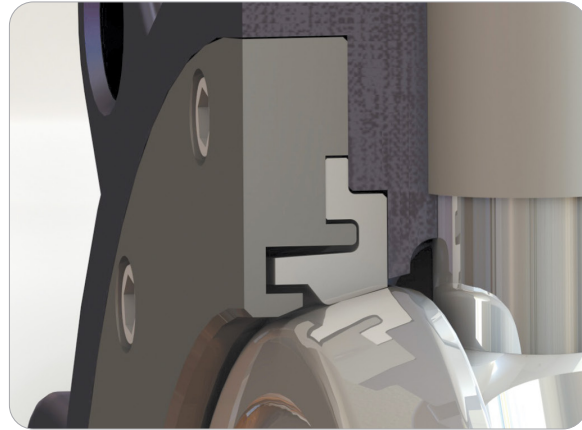

Recommended Flow Direction →

Fire Safe Seat Design

- Solid seat with metal back up seat, free floating, pressure assisted seal
- No additional parts are required to maintain positive seal
- ABZolute 400 Series Fire Safe valves are rated full ANSI pressure
- API 607 Fire Safe tested
- Class VI shut off before fire and Class V shut off after fire

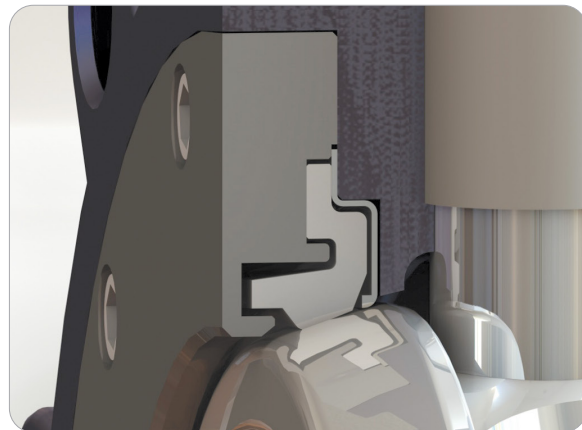

Recommended Flow Direction →

Metal Seat Design

- Machined metal seat, free floating, Uni-Directional, pressure Assisted seal
- ABZolute 400 Series metal seated valves are rated full ANSI pressure
- API 607 Fire Safe tested
- Class V Uni-Directional shut off

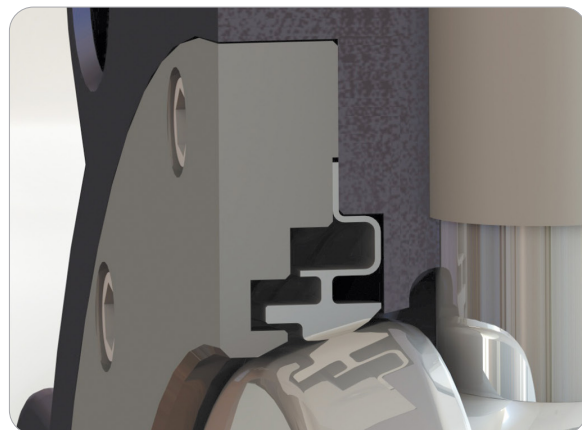

Recommended Flow Direction →

Note: Soft and Fire Safe Seated valves are rated for vacuum. Valves in vacuum service should be installed with vacuum on downstream side of valve. (Shaft side)

ABZolute Double Offset High Performance Butterfly Valves

ABZ 400 Series



Wafer Pattern

Fig. ABZ 401 – ANSI 150
Fig. ABZ 421 – ANSI 300
Fig. ABZ 451 – ANSI 600

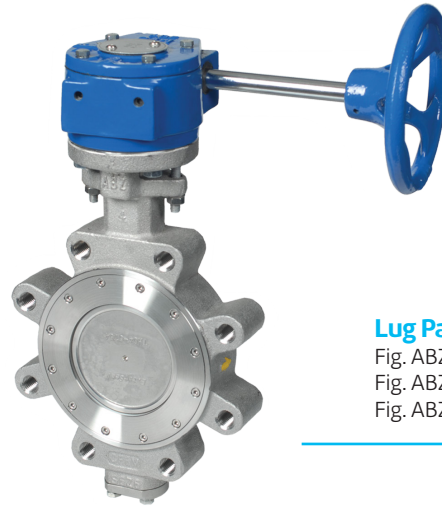

Lug Pattern

Fig. ABZ 402 – ANSI 150
Fig. ABZ 422 – ANSI 300
Fig. ABZ 452 – ANSI 600

Manufacture Standard

	End Connection	Wafer Type, Lug Type	Flange Type	Butt Weld Type
Design Standard	ABZ Standard	API 609 & ANSI/ASME B16.34 API 607 (Fire Safe Test)	API 609 & ANSI/ASME B16.34	ANSI/ASME B16.34 & ANSI/ASME B 16.25
	Optional Configurations	BS 5155	BS 5155	
Face to Face	ABZ Standard	API 609 Category B MSS-SP-68 Table 1 ANSI/ASME B 16.10 Table 8 ISO 5752 Table 1 & BS 5155	ISO 5752 Table 6 BS 5155 Table 6 ANSI/ASME B 16.10 Table 6 (Only 2" & 2.5")	ISO 5752 Table 4 BS 5155 Table 6
	Optional Configurations	DIN 3202 ISO 5752 BS 5155	DIN 3202 ISO 5752 BS 5155	
Flange Connection	ABZ Standard	ANSI/ASME B 16.5 CL150, 300, 600 ANSI/ASME B 16.47 Series A CL150, 300 MSS-SP-44:CL150, 300, 600 API 605 : CL.150, CL.300	ANSI/ASME B 16.5 CL150, 300, 600 ANSI/ASME B 16.47 Series A CL150, 300 MSS-SP-44:CL150, 300, 600 API 605 : CL.150, CL.300	Butt Welding according to ANSI/ASME B16.25
	Optional Configurations	JIS B 2210 10K,16K, 20K, 30K, 40K DIN02501, ISO 7005-1 PN10, PN16, PN20, PN25, PN40	JIS B 2210 10K,16K, 20K, 30K, 40K DIN02501, ISO 7005-1 PN10, PN16, PN20, PN25, PN40	
Testing	ABZ Standard	API 598 ANSI/ASME B 16.34 BS 1560 BS 5155	API 598 ANSI/ASME B 16.34 BS 1560 BS 5155	API 598 ANSI/ASME B 16.34
	Optional Configurations	JIS B 2203, 2201 DIN 3230 ISO 7005 FCI 70-2 ANSI/ASME B 16.104 MSS-SP 61	JIS B 2203, 2201 DIN 3230 ISO 7005 FCI 70-2 FCI 70-2 ANSI/ASME B 16.104 MSS-SP 61	MSS-SP 61 ANSI/ASME B 16.104

Double Flanged Pattern Available.

ABZolute Double Offset High Performance Butterfly Valves

ABZ 400 Series



ABZolute - ANSI 150 Soft Seat - Temp/pressure

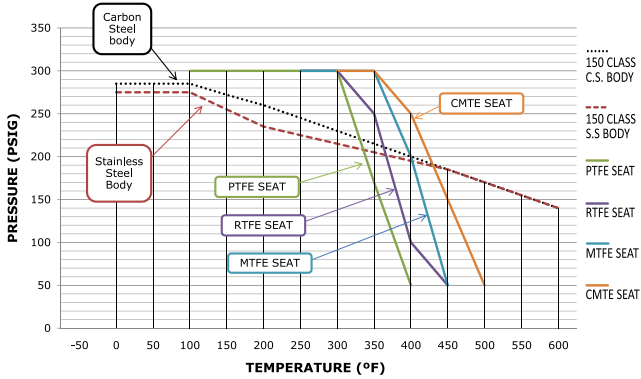

The pressure/temperature rating is determined by the seat or body rating whichever is less.

ABZolute - ANSI 150 Fire Safe And Metal Seat - Temp/pressure

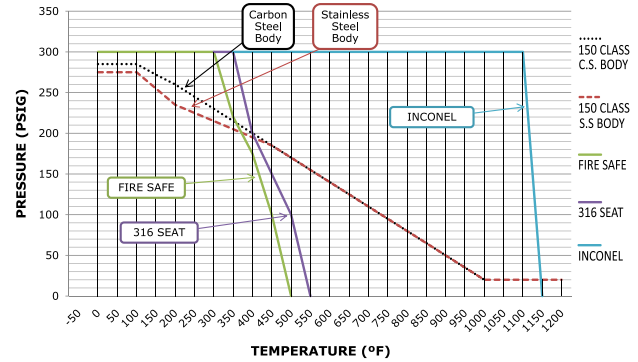

The pressure/temperature rating is determined by the seat or body rating whichever is less.

ABZolute - ANSI 300 Soft Seat - Temp/pressure

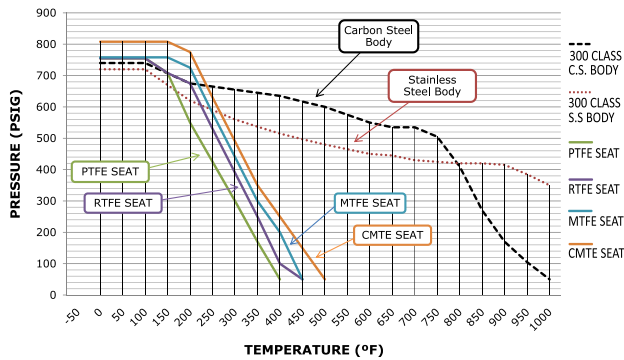

The pressure/temperature rating is determined by the seat or body rating whichever is less.

ABZolute - ANSI 300 Fire Safe And Metal Seat - Temp/pressure

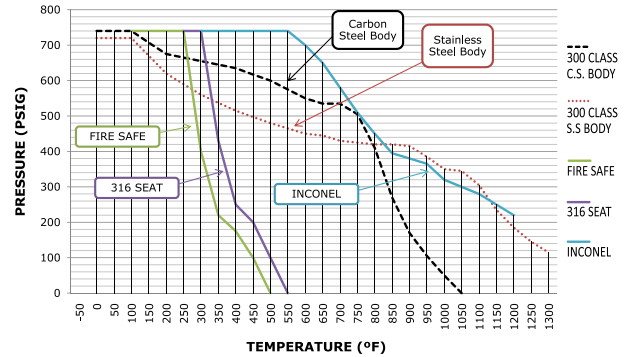

The pressure/temperature rating is determined by the seat or body rating whichever is less.

ABZolute - ANSI 600 Soft Seat - Temp/pressure

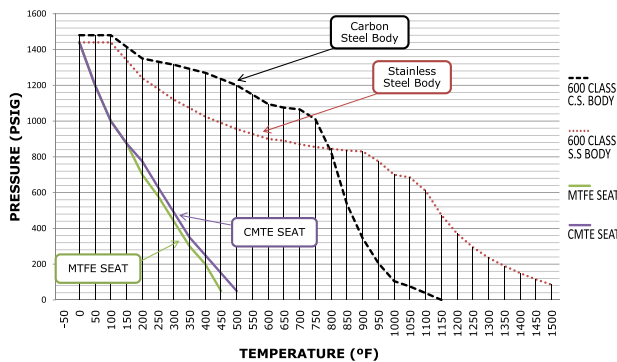

The pressure/temperature rating is determined by the seat or body rating whichever is less.

ABZolute - ANSI 600 Fire Safe And Metal Seat - Temp/pressure

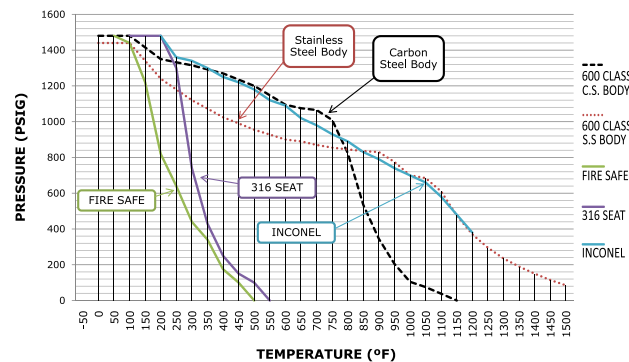

The pressure/temperature rating is determined by the seat or body rating whichever is less.

ABZolute Double Offset High Performance Butterfly Valves

ABZ 400 Series



Dimensions Wafer & Lug Type ABZolute 400 Series

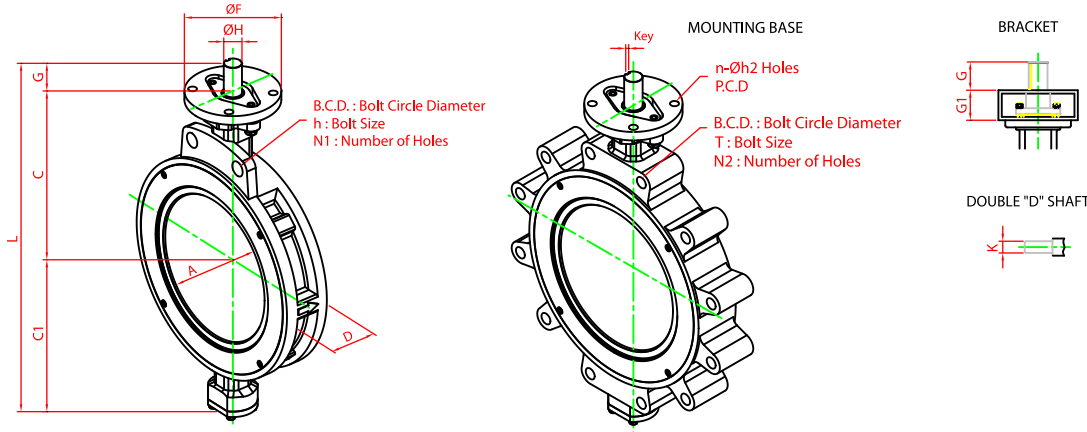

ANSI - 150 (ANSI B16.5, ANSI B16.47 Series A)

Size inch	Flange Dimensions											Mounting Dimensions						
	A	D	L	C	C1	G	G1	K	H	F	B.C.D	H	T	N1	N2	P.C.D	N	H2
2	1.85	1.69	10.12	4.92	3.94	1.26	-	0.374	0.551	4.02	4.75	0.750	5/8" x 11unc	2	4	3.25	4	0.43
2.5	2.40	1.85	11.15	5.87	4.02	1.26	-	0.437	0.626	4.02	5.50	0.750	5/8" x 11unc	2	4	3.25	4	0.43
3	2.83	1.89	11.97	6.30	4.41	1.26	-	0.437	0.626	4.02	6.00	0.750	5/8" x 11unc	2	4	3.25	4	0.43
4	3.74	2.13	13.15	7.01	4.88	1.26	-	0.500	0.748	4.02	7.50	0.750	5/8" x 11unc	2	8	3.25	4	0.43
5	4.65	2.24	14.41	7.60	5.55	1.26	-	0.500	0.748	4.02	8.50	0.875	3/4" x 10unc	2	8	3.25	4	0.43
6	5.43	2.24	16.22	8.39	6.57	1.26	-	0.500	0.748	4.02	9.50	0.875	3/4" x 10unc	2	8	3.25	4	0.43
8	7.40	2.52	18.39	9.45	7.68	1.26	-	0.626	0.874	5.98	11.75	0.875	3/4" x 10unc	2	8	5.00	4	0.55
10	9.25	2.83	21.73	11.02	8.66	2.05	-	.25 x .25	1.126	5.98	14.25	1.000	7/8" x 9unc	2	12	5.00	4	0.55
12	10.83	3.19	24.64	12.20	10.43	2.01	-	.25 x .25	1.126	5.98	17.00	1.000	7/8" x 9unc	2	12	5.00	4	0.55
14	12.48	3.62	27.24	13.19	11.81	2.24	-	.31 x .31	1.374	5.98	18.75	1.125	1" x 8unc	2	12	5.00	4	0.55
16	14.13	4.02	31.85	15.47	13.39	2.99	-	.50 x .50	1.874	8.03	21.25	1.125	1" x 8unc	2	16	6.50	4	0.83
18	16.38	4.49	34.56	16.81	14.76	2.99	-	.50 x .50	1.874	8.03	22.75	-	1 1/8" x 8un	4	16	6.50	4	0.83
20	18.39	5.00	36.46	17.72	15.75	2.99	-	.50 x .50	2.126	8.03	25.00	-	1 1/8" x 8un	4	20	6.50	4	0.83
22	20.00	6.06	40.63	19.29	17.32	4.02	-	.75 x .50	2.555	11.42	27.25	-	1 1/4" x 8un	4	20	10.00	8	0.75
24	21.57	6.06	43.59	20.87	18.70	4.02	-	.75 x .50	2.555	11.42	29.50	-	1 1/4" x 8un	4	20	10.00	8	0.75
28	25.12	6.50	49.49	23.62	21.85	4.02	-	.75 x .50	2.555	11.42	34.00	-	1 1/4" x 8un	4	28	10.00	8	0.75
30	27.01	7.48	52.87	25.39	23.03	4.45	-	.87 x .55	3.146	12.99	36.00	-	1 1/4" x 8un	4	28	10.00	8	0.75
36	33.03	7.99	59.57	28.74	26.38	4.45	-	.87 x .55	3.146	12.99	42.75	-	1 1/2" x 8un	4	32	10.00	8	0.75
42	39.45	9.49	72.83	30.71	31.10	4.72	6.30	1.10 x .63	3.933	-	49.50	-	1 1/2" x 8un	8	36	11.73	8	0.91
48	44.37	10.00	81.69	34.65	35.43	5.31	6.30	1.26 x .71	4.720	-	56.00	-	1 1/2" x 8un	8	44	11.73	8	0.91

ABZolute Double Offset High Performance Butterfly Valves

ABZ 400 Series



ANSI – 300 (ANSI B16.5, ANSI B16.47 Series A)

Size inch	Flange Dimensions													Mounting Dimensions				
	A	D	L	C	C1	G	G1	K	H	F	B.C.D	H	T	N1	N2	P.C.D	N	H2
2	1.85	1.73	10.12	4.92	3.94	1.26	-	0.374	0.551	4.02	5.00	0.750	5/8" x 11unc	2	8	3.25	4	0.43
2.5	2.40	1.89	11.15	5.87	4.02	1.26	-	0.437	0.626	4.02	5.88	0.875	3/4" x 10unc	2	8	3.25	4	0.43
3	2.83	1.93	11.97	6.30	4.41	1.26	-	0.437	0.626	4.02	6.62	0.875	3/4" x 10unc	2	8	3.25	4	0.43
4	3.74	2.13	13.15	7.01	4.88	1.26	-	0.500	0.748	4.02	7.88	0.875	3/4" x 10unc	2	8	3.25	4	0.43
5	4.65	2.24	14.41	7.60	5.55	1.26	-	0.500	0.748	4.02	9.25	0.875	3/4" x 10unc	2	8	3.25	4	0.43
6	5.39	2.32	16.85	8.66	6.93	1.26	-	0.500	0.748	4.02	10.62	0.875	3/4" x 10unc	2	12	3.25	4	0.43
8	7.32	2.87	20.71	10.24	8.46	2.01	-	.25 x .25	1.126	5.98	13.00	1.000	7/8" x 9unc	2	12	5.00	4	0.55
10	9.06	3.27	22.96	11.42	9.53	2.01	-	.25 x .25	1.126	5.98	15.25	-	1" x 8unc	4	16	5.00	4	0.55
12	10.79	3.62	25.56	12.80	10.75	2.01	-	.31 x .31	1.374	5.98	17.75	-	1 1/8" x 8un	4	16	5.00	4	0.55
14	12.32	4.61	30.55	14.76	12.80	2.99	-	.50 x .50	1.874	8.03	20.25	-	1 1/8" x 8un	4	20	6.50	4	0.83
16	14.02	5.24	34.09	16.73	14.37	2.99	-	.50 x .50	2.122	8.03	22.50	-	1 1/4" x 8un	4	20	6.50	4	0.83
18	16.26	5.87	38.47	18.31	16.14	4.02	-	.75 x .50	2.555	11.42	24.75	-	1 1/4" x 8un	4	24	10.00	8	0.75
20	18.35	6.26	41.62	19.88	17.72	4.02	-	.75 x .50	2.555	11.42	27.00	-	1 1/4" x 8un	4	24	10.00	8	0.75
24	21.50	7.13	47.83	22.83	20.55	4.45	-	.87 x .55	3.146	12.99	32.00	-	1 1/2" x 8un	4	24	10.00	8	0.75
30	27.17	9.06	62.59	25.59	25.98	4.72	6.30	1.10 x .63	3.933	-	39.25	-	1 3/4" x 8un	4	28	11.73	8	0.91
36	33.46	10.75	71.25	29.92	29.72	5.31	6.30	1.26 x .71	4.720	-	46.00	-	2" x 8un	8	32	11.73	8	0.91
48	43.07	13.78	86.21	36.61	34.84	6.89	7.87	1.77 x .98	7.039	-	54.00	-	1 7/8" x 8un	8	32	15.98	8	1.54

ANSI – 600 (ANSI B16.5)

Size inch	Flange Dimensions													Mounting Dimensions				
	A	D	L	C	C1	G	G1	K	H	F	B.C.D	H	T	N1	N2	P.C.D	N	H2
3	2.91	2.17	12.67	6.57	4.92	1.18	-	0.500	0.748	4.02	6.62	0.875	3/4" x 10unc	2	8	3.25		0.43
4	3.78	2.52	14.65	7.68	5.71	1.26	-	0.626	0.874	5.98	8.50	1.000	7/8" x 9unc	2	8	5.00	4	0.55
6	5.20	3.07	19.76	9.45	8.07	2.24	-	.31 x .31	1.374	5.98	11.50	-	1" x 8unc	4	12	5.00	4	0.55
8	6.85	4.06	23.86	11.42	9.45	2.99	-	.50 x .50	1.874	8.03	13.75	-	1 1/8" x 8un	4	12	6.50	4	0.83
10	8.78	4.61	27.20	13.19	11.02	2.99	-	.50 x .50	1.874	8.03	17.00	-	1 1/4" x 8un	4	16	6.50	4	0.83
12	10.59	5.51	31.90	15.16	12.72	4.02	-	.75 x .50	2.358	11.72	19.25	-	1 1/4" x 8un	4	20	10.00	8	0.75
14	11.81	6.10	35.72	17.13	14.57	4.02	-	.75 x .50	2.555	11.42	20.75	-	1 3/8" x 8un	4	20	10.00	8	0.75
16	13.74	7.01	38.66	18.70	15.94	4.02	-	.75 x .50	2.555	11.42	23.75	-	1 1/2" x 8un	4	20	10.00	8	0.75
18	15.59	7.87	41.86	19.69	17.72	4.45	-	.87 x .55	3.146	12.99	25.75	-	1 5/8" x 8un	4	20	10.00	8	0.75
20	17.72	8.50	49.61	19.69	19.29	4.72	5.91	1.10 x .63	3.933	-	28.50	-	1 5/8" x 8un	4	24	11.73	8	0.91
24	21.50	9.13	56.88	22.83	23.03	4.72	6.30	1.10 x .63	3.933	-	33.00	-	1 7/8" x 8un	4	24	11.73	8	0.91

• 26" and larger API Flange Patterns are available – consult factory
 • Double Flanged Patterns are available – consult factory

• Larger sizes available
 • Custom sizes available

ABZolute Double Offset High Performance Butterfly Valves



ABZ 400 Series

Cv Value of Series 400 ABZolute Seal Double Offset High Performance Valves

Cv is defined as the volume of water in U.S.G.P.M. that will flow through a given restriction or valve opening with a pressure drop of one (1) PSI at room temperature. Recommended control angles are between 25°–70° open. Preferred angle for control valve sizing is 60°–65° open. This chart is calculated and is to be used as a guide only.

ANSI – 150

Size		Angle of Opening (Degrees)									
Inch	mm	Class	10°	20°	30°	40°	50°	60°	70°	80°	90°
2	50	150	2	5	12	19	32	45	65	81	88
2½	65	150	3	9	21	33	54	77	111	138	150
3	80	150	5	14	32	50	82	116	168	209	227
4	100	150	9	25	57	90	148	209	303	377	410
5	125	150	16	44	104	163	266	377	548	681	740
6	150	150	25	65	150	235	380	540	785	975	1060
8	200	150	55	130	305	480	785	1110	1615	2005	2200
10	250	150	85	205	475	750	1225	1735	2520	3135	3400
12	300	150	115	280	655	1025	1680	2380	3450	4290	4700
14	350	150	150	355	830	1305	2140	3030	4395	5465	5900
16	400	150	200	475	1115	1750	2860	4055	5880	7310	7900
18	450	150	265	630	1475	2315	3790	5365	7790	9680	10500
20	500	150	345	830	1935	3040	4975	7050	10230	12715	13800
22	550	150	375	975	2275	3580	5855	8295	12035	14960	16300
24	600	150	485	1265	2955	4640	7590	10755	15605	19405	21100
26	650	150	550	1450	3350	5300	8650	12250	17800	22100	24000
28	700	150	650	1750	4050	6350	10350	14650	21300	26450	28800
30	750	150	750	2000	4600	7250	11900	16850	24400	30350	33000
32	800	150	850	2350	5450	8600	14050	19900	28850	35850	39000
34	850	150	1000	2750	6450	10150	16650	23550	34200	42500	46200
36	900	150	1100	2950	6900	10900	17800	25200	36600	45500	49400
40	1000	150	1550	4000	9300	14650	23950	33900	49200	60500	66500
42	1050	150	1650	4350	10100	15900	26000	36850	53450	65000	72200
48	1200	150	2350	6100	14200	22350	36550	51800	75150	91450	101600

ABZolute Double Offset High Performance Butterfly Valves

ABZ 400 Series



ANSI - 300

Size		Angle of Opening (Degrees)									
Inch	mm	Class	10°	20°	30°	40°	50°	60°	70°	80°	90°
2	50	300	2	5	12	19	32	45	65	81	88
2½	65	300	3	9	21	33	54	77	111	138	150
3	80	300	5	14	32	50	82	116	168	209	227
4	100	300	9	25	57	90	148	209	303	377	410
5	125	300	16	44	104	163	266	377	548	681	740
6	150	300	24	60	139	218	357	506	735	914	995
8	200	300	45	110	260	410	670	945	1375	1710	1900
10	250	300	75	175	415	650	1065	1505	2185	2720	3000
12	300	300	105	250	580	910	1495	2115	3070	3815	4100
14	350	300	135	325	755	1185	1940	2750	3985	4955	5400
16	400	300	175	415	970	1520	2490	3525	5120	6365	6900
18	450	300	245	590	1375	2165	3540	5015	7275	9045	9800
20	500	300	315	760	1770	2780	4555	6450	9360	11635	12600
24	600	300	435	1135	2645	4155	6800	9635	13980	17380	18900
30	750	300	650	1750	4050	6400	10450	14800	21500	26700	29000
36	900	300	1000	2700	6300	9900	16200	22900	33250	41350	44900

ANSI - 600

Size		Angle of Opening (Degrees)									
Inch	mm	Class	10°	20°	30°	40°	50°	60°	70°	80°	90°
3	80	600	3	9	21	33	54	77	112	139	151
4	100	600	5	15	34	53	87	124	180	224	243
6	150	600	15	38	88	139	228	322	468	581	630
8	200	600	30	70	160	250	410	580	845	1050	1100
10	250	600	50	120	285	450	735	1040	1510	1875	2000
12	300	600	70	165	380	600	980	1390	2015	2505	2700
14	350	600	90	220	515	810	1330	1880	2730	3395	3700
16	400	600	125	305	705	1110	1820	2575	3735	4645	5100
18	450	600	135	325	765	1200	1965	2780	4035	5015	5500
20	500	600	195	470	1095	1715	2810	3980	5775	7180	7800
24	600	600	300	750	1750	2750	4500	6400	9250	11500	12500

ABZolute Double Offset High Performance Butterfly Valves

ABZ 400 Series

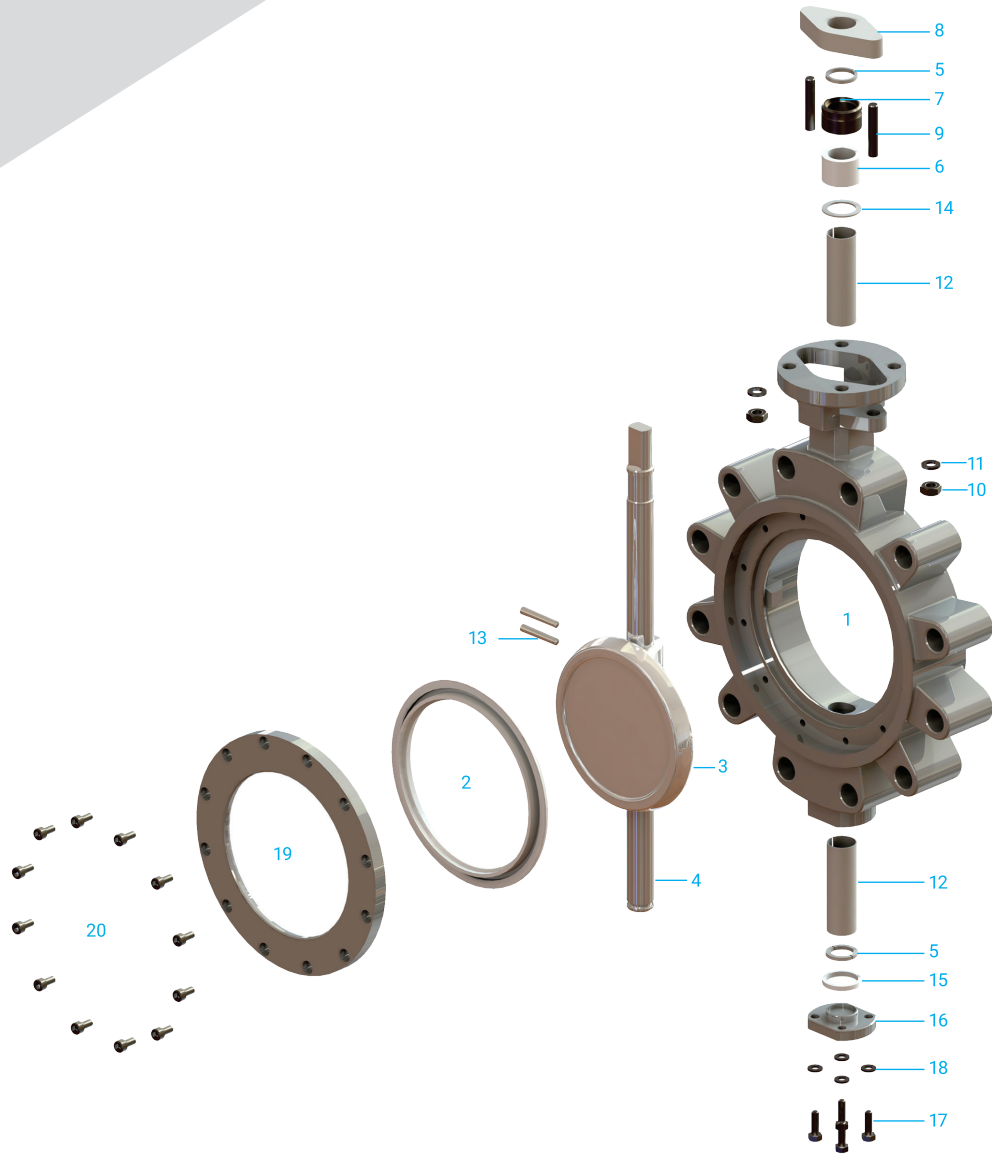

Standard Parts Schedule

1. **Body:** A216-WCB Carbon Steel
A351-CF8M 316 Stainless Steel
2. **Seat Ring:** Soft / Metal / Fire Safe
3. **Disc:** A351-CF8M (316 Stainless Steel)
4. **Stem:** 17/4 PH Stainless Steel
5. **Retainer Ring:** 316 Stainless Steel
6. **Packing:** PTFE Graphite
7. **Packing Gland:** 316 Stainless Steel
8. **Gland Flange:** A351-CF8M
(316 Stainless Steel)
9. **Gland Bolt:** Stainless Steel
10. **Nut:** Stainless Steel

11. **Spring Washer:** Stainless Steel
12. **Bush Bearing:** RTFE + S.S. or Graphite + S.S.
13. **Disc Pin:** Stainless Steel
14. **Packing Retainer:** Stainless Steel
15. **Cap Packing:** PTFE or Graphite
16. **Cap:** A216-WCB Carbon Steel
A351-CF8M 316 Stainless Steel
17. **Cap Bolt:** Stainless Steel
18. **Spring Washer:** Stainless Steel
19. **Seat Retainer:** A216-WCB Carbon Steel
A351-CF8M 316 Stainless Steel
20. **Retainer Bolt:** Stainless Steel

Available Materials

- Hastelloy
- Duplex 2205
- ALX6N
- SMO 254/255
- Monel

Other materials are available on request.

About ASC Engineered Solutions

ASC Engineered Solutions is defined by quality—in its products, services and support. With more than 1,400 employees, the company's portfolio of precision-engineered piping support, valves and connections provides products to more than 4,000 customers across industries, such as mechanical, industrial, fire protection, oil and gas, and commercial and residential construction. Its portfolio of leading brands includes ABZ Valve®, AFCON®, Anvil®, Anvil EPS, Anvil Services, Basic-PSA, Beck®, Catawissa, Cooplet®, FlexHead®, FPPI®, Gruklok®, J.B. Smith, Merit®, North Alabama Pipe, Quadrant®, SCI®, Sharpe®, SlideLOK®, SPF® and SprinkFLEX®. With headquarters in Commerce, CA, and Exeter, NH, ASC also has ISO 9001:2015 certified production facilities in PA, TN, IL, TX, AL, LA, KS, and RI.



asc-es.com

Building connections that last™

FC-DS-ABZ ABZolute 400-v01 20210506

