

3099CGD

APPROX. DRAIN AREA = 409.94 SQ IN
 APPROX. WEIGHT WITH FRAME = 93.00 LBS

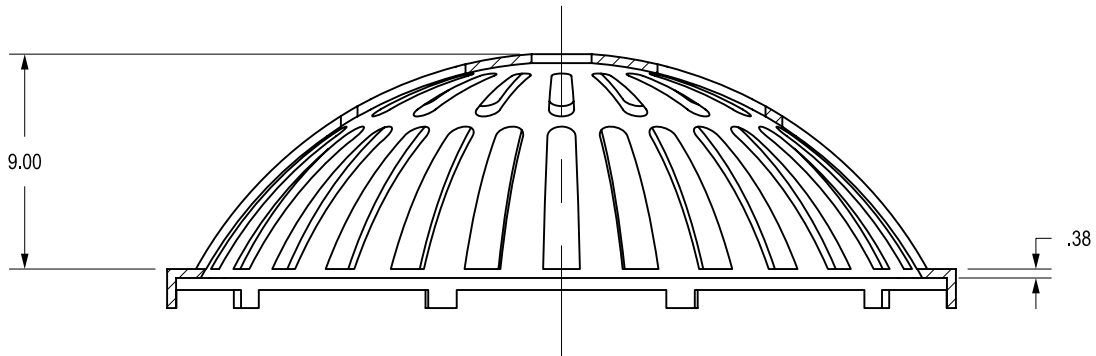
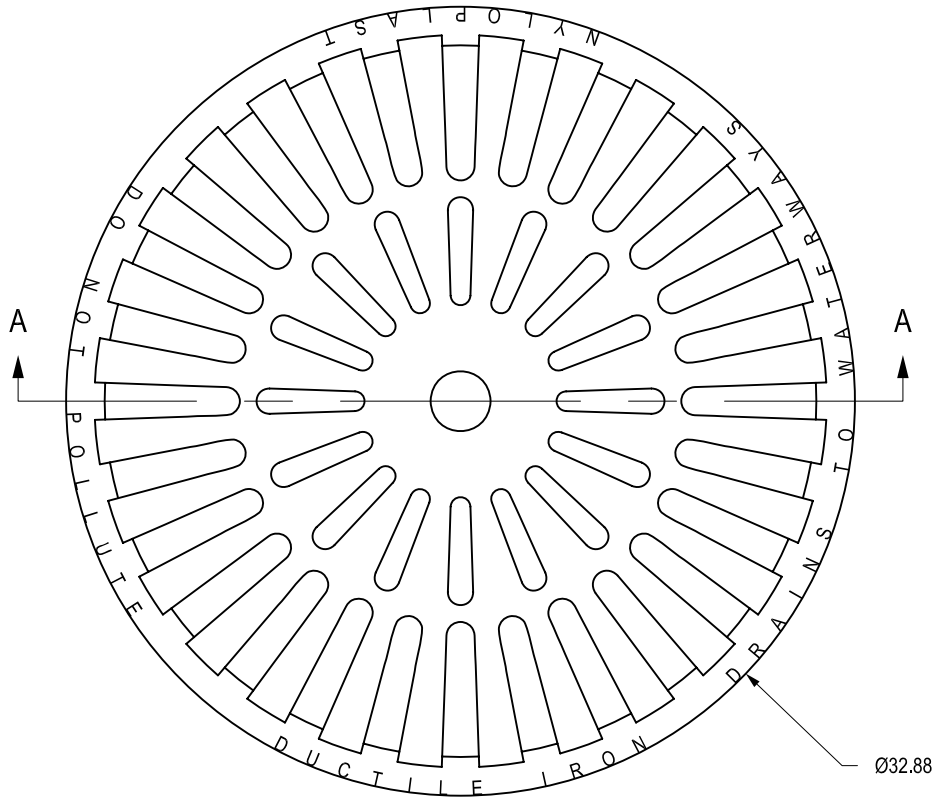

SECTION A-A

DIMENSIONS ARE FOR REFERENCE ONLY
 ACTUAL DIMENSIONS MAY VARY
 DIMENSIONS ARE IN INCHES
 QUALITY: MATERIALS SHALL CONFORM TO ASTM A536 GRADE 70-50-05
 PAINT: CASTINGS ARE FURNISHED WITH A BLACK PAINT
 LOCKING DEVICE AVAILABLE UPON REQUEST

THIS PRINT DISCLOSES SUBJECT MATTER IN WHICH NYLOPLAST HAS PROPRIETARY RIGHTS. THE RECEIPT OR POSSESSION OF THIS PRINT DOES NOT CONFER, TRANSFER, OR LICENSE THE USE OF THE DESIGN OR TECHNICAL INFORMATION SHOWN HEREIN REPRODUCTION OF THIS PRINT OR ANY INFORMATION CONTAINED HEREIN, OR MANUFACTURE OF ANY ARTICLE HEREFROM, FOR THE DISCLOSURE TO OTHERS IS FORBIDDEN, EXCEPT BY SPECIFIC WRITTEN PERMISSION FROM NYLOPLAST.

©2011 NYLOPLAST

DRAWN BY	EBC	MATERIAL	DUCTILE IRON
DATE	3-8-06	PROJECT NO./NAME	
REVISED BY	EBC	DATE	3-10-11
DWG SIZE	A	SCALE	1:8
		SHEET	1 OF 1



3130 VERONA AVE
 BUFORD, GA 30518
 PHN (770) 932-2443
 FAX (770) 932-2490
 www.nyloplast-us.com

TITLE	30 IN DOME GRATE		
DWG NO.	7001-110-223	REV	D