

CONDENSATE PUMP SELECTION GUIDE

BlueDiamond™

The only fit and forget condensate pumps



MaxiBlue™



MegaBlue™

 **sauermann®**

Si-30 120 V



Si-30 230 V

BlueDiamond™ CONDENSATE PUMP SELECTION GUIDE



Plenum-Rated



MaxiBlue™

- Flow rate up to 3.7 gph
- Dry suction lift up to 16.5 ft
- Max head of 23 ft
- Self priming
- Energy Efficient

Model	Voltage [V]
X87-711	110
X87-721	208-230



Plenum-Rated



MegaBlue™

- Flow rate up to 13.2 gph
- Max head of 66.5 ft
- Thermally protected
- Self Priming

Model	Voltage [V]
X87-831	110
X87-835	208-230

MultiTank™



- **Ultra reliable** - incorporates electronic level sensing with no moving parts
- **Whisper quiet** - reliably removes condensate
- **Multi port** - up to 6 condensate lines
- **Impact resistant** - exceptionally high durability
- **Fit fast** - floor or wall mounted

Model	Voltage [V]
C13-103	N/A

* Not available with reservoir sensor to provide automatic shutoff

Blue Diamond Pumps feature:

- Exceptional performance from a small package
- Exceptionally quiet with no vibration
- Can tolerate both small debris and running dry
- Can be mounted in any position
- UL certified plenum rated
- Includes flexible and rigid cone adaptor

Additional Accessories

F10-010
Mounting Feet



C13-103
MegaBlue/MaxiBlue
Extension Cable 5m



C13-192
Extension



Installation Possibilities

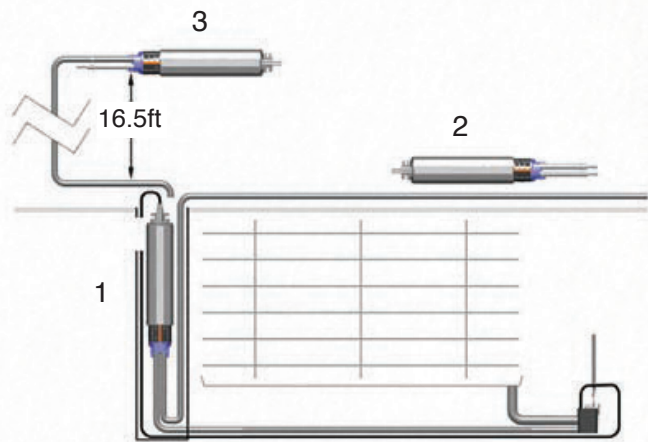

- ① Inside Line Hide ② Above Ceiling ③ Remote

Blue Diamond pumps are slim enough to fit into line hide or ducting, powerful enough for distant location and quiet enough for ceiling mounting. It's your choice. Commissioning is so easy, linkpump to sensing option with single wire DIN plug and connect in/out tubing provided - plug and play, fit and forget!

What's in the Box

Snapper Clip



Rigid Stepped
Adaptor



Flexible Stepped
Adaptor



Sensing
Option



MaxiBlue™

MegaBlue™



BlueDiamond™ CONDENSATE PUMP SELECTION GUIDE

Performance Charts

MaxiBlue™



Plot of Flow Rate Against Head

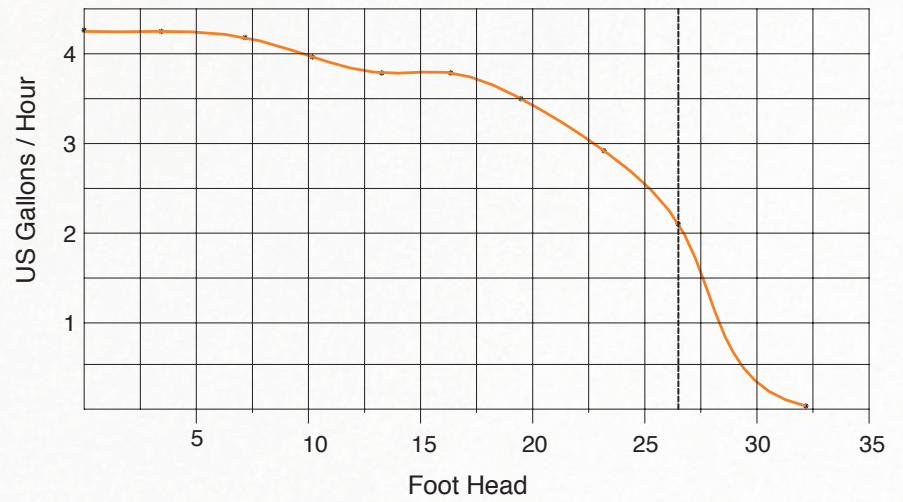

MegaBlue™



Plot of FlowRate Against Head

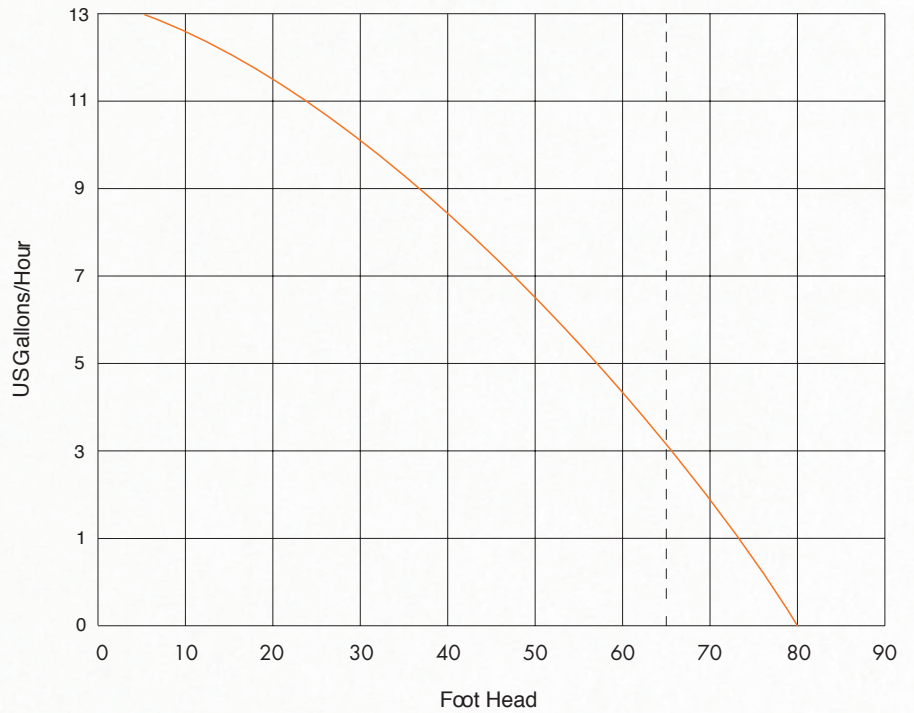



Si-30 120/230V

- Flow rate up to 5.0 gph
- Suction head up to 10 ft
- Discharge head up to 33 ft
- Small size / High performance

Additional Accessories

Detection Unit



Check valve



PVC Tubing



Self-sealing accessory



Actual Flow Rates (GPH)

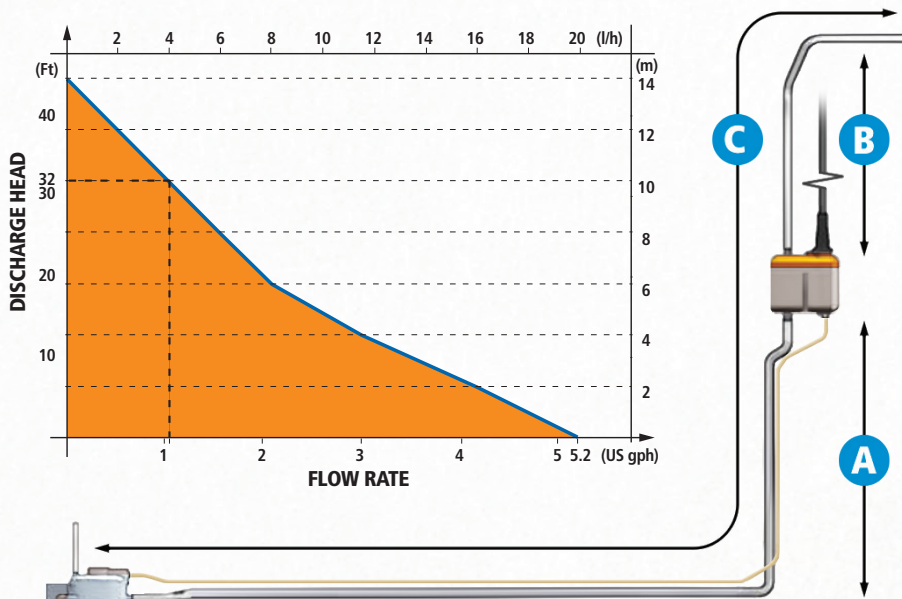

A Suction head	B Discharge head	C Total tube length using 1/4" (6mm) hose			
		15 ft (4.5m)	30 ft (9m)	60 ft (18m)	100 ft (30m)
0 ft (0m)	0 ft (0m)	5.0	4.7	4.5	4.2
	6 ft (2m)	4.2	3.9	3.7	3.5
	13 ft (4m)	3	2.9	2.8	2.6
	20 ft (6m)		2.5	2	1.7
	26 ft (8m)		1.6	1.3	1.1
3.3 ft (1m)	33 ft (10m)		1.1	0.9	0.7
	0 ft (0m)	3.7	3.4	3.2	2.9
	6 ft (2m)	2.9	2.6	2.4	2.1
	13 ft (4m)	0.5	1.8	1.6	1.3
6.6 ft (2m)	20 ft (6m)		1.2	1.1	
	0 ft (0m)	2.9	2.6	2.4	2.1
	6 ft (2m)	2.4	2.1	1.8	1.6
10 ft (3m)	13 ft (4m)		1.5	1.3	1.2
	0 ft (0m)	2.6	2.4	2.1	1.8
	6 ft (2m)	2.1	1.8	1.6	1.3
	13 ft (4m)		1.3	1.1	

BlueDiamond™

MaxiBlue™

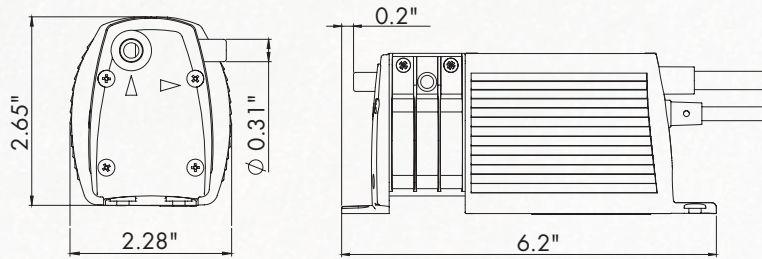

MegaBlue™

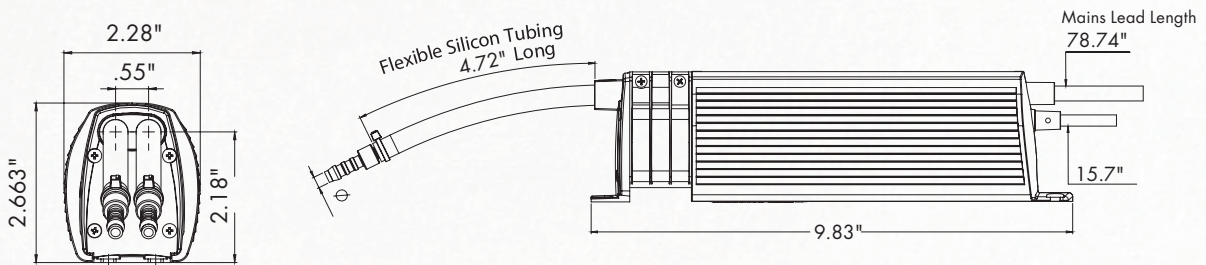

MultiTank

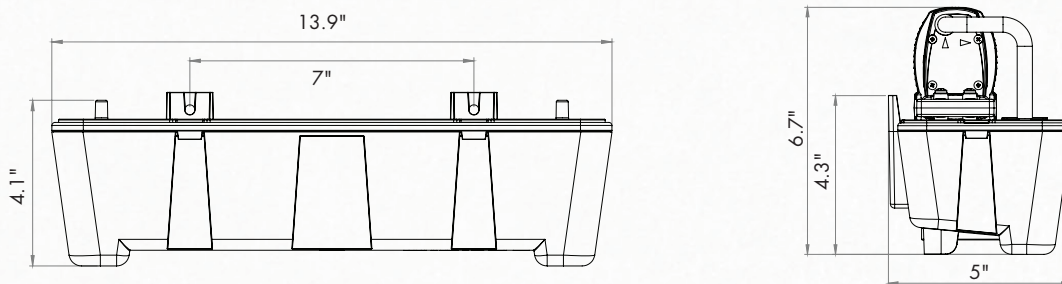

Si30

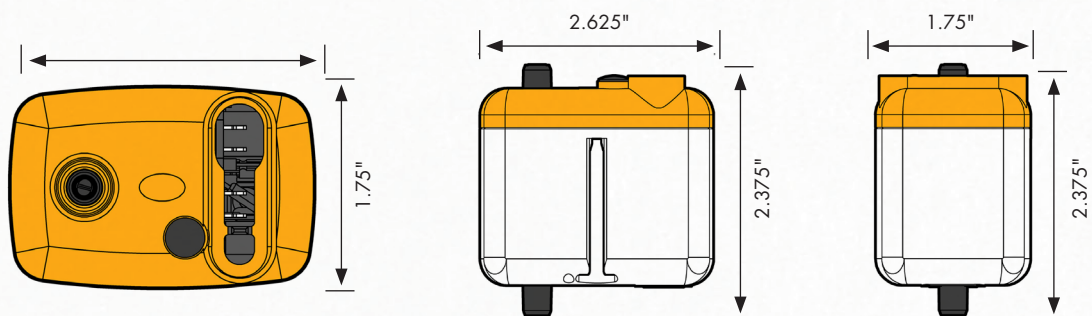

Specifications

Manufacturer	Blue Diamond		Sauermann
Model	MaxiBlue	MegaBlue	Si30
Flow [g/hr]	3.7	13.2	5
Head [ft]	23	66.5	33
Suction Lift [ft head]	16.5	23	10
Sound Pressure [dBA]	25.5	39.5	20
Sensor—Liquid in Drainpan	Thermistor	Thermistor	Float Switch
Pass Solids up to 1 mm	Yes	Yes	Yes
Thermal Protection (Overheat)	257° F	257° F	194° F
Intermittent Operation Cycle	No Limit	No Limit	3s On—7s OFF
Run Dry for Extended Period	Yes	Yes	"No
Mounting Position	Any Orientation	Any Orientation	Mounted vertically or horizontally
Self-Priming	Yes	Yes	Yes
Drain Screen/Filter requiring cleaning	No	No	No
Voltage Options [V]	110/230	110/230	120/230
Weight [kg]	0.7	1.0	0.4
Temp. Sensing	X	X	
Reservoir Sensing*	X	X	X
DrainStik	X	X	
Cooling Signal		X	
Unit Disconnect Sensor	X	X	No
UL Certified	Yes	Yes	Yes
Plenum Rated	Yes	Yes	No
Manufacturer Warranty	3 Years	3 Years	2 Year
Tier	1	2	1

* Standard Option

MOISTURE REMOVAL CHARTS

CITY MULTI

Model	Tier
PKFY-P06-30NBMU-E2	1
PKFY-P06-30NHMU-E2	1
PKFY-P06-30NKMU-E2	1
PCFY-P15-36NKMU-ER1	1
PCFY-P24-36NKMU-ER1	1
PFFY-P06-24NEMU-E	1
PFFY-P06-24NRMU-E	1
PVfy-P12-54E00B	1
PEFY-P15-48NMHU-E2	1
PEFY-P54NMHU-E	2
PEFY-P06-54NMAU-E3	1
PEFY-P06-24NMSU-E2	1
PEFY-P72-96NMSHU-E	2

M-SERIES

P-SERIES

Model	Tier
MS-A09-12WA-1	1
MSY-GE09-18NA-8	1
MSY-GE24NA	1
MSY-D30-36NA-8	1
MSZ-FE09-12NA-8	1
MSZ-FE18NA	1
MSZ-GE06NA-8	1
MSZ-GE09-18NA-8	1
MSZ-GE24NA	1
MSZ-D30-36NA-8	1
MFZ-KA09-18NA	1
PKA-A12-18HA4	1
PKA-A24KA4	1
PKA-A30-36KA4	1
PCA-A24KA4	1
PCA-A30-42KA4	1



Mitsubishi Electric Cooling & Heating
 1340 Satellite Boulevard, Suwanee, GA 30024
 Phone: 800-433-4822 Fax: 800-658-1458

