

Controller

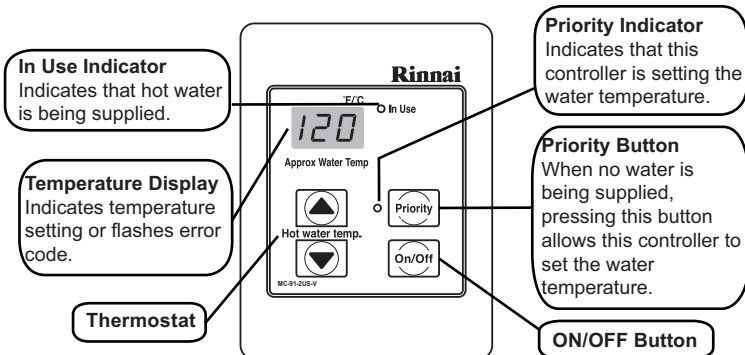

Gas Pressure Setting

Ensure gas pressure check under Commissioning has been completed first! The regulator is electronically controlled and factory pre-set. Under normal circumstances it does not require adjustment during installation. Make adjustments only if the unit is not operating correctly and all other possible causes for incorrect operation have been eliminated.

- Turn OFF the gas supply.
- Turn OFF the water supply.
- Remove the front panel (four screws).
- Check the gas type using the data plate on the side of the unit. Confirm that the gas type switch is in the correct position (switch 1 of Dip SW2 is ON for natural gas, NG, and OFF for propane gas, LPG.) Figure 1.
- Remove the screw and attach the manometer to the burner test point located on the gas control. Figure 2.
- Turn on the gas supply and the power supply.
- Flow water through the water heater at the maximum flow rate obtainable. (At least 3 gallons per minute is recommended. If there is not enough water flowing, the water heater could shut off or sustain damage due to overheating.)
- Move switch 8 of Dip SW1 to ON. Figure 3.
- Push the PC board switch A for one second. Figure 4.
- Calibrate "Forced Low" combustion using switch A (up) and switch B (down).
- Move switch 8 of Dip SW1 to OFF and then back to ON. Figure 6.
- Push the PC board switch B for one second. Figure 4.
- Calibrate "Forced High" combustion using switch A (up) and switch B (down).
- Move switch 8 of Dip SW1 to OFF. Figure 5.
- Close hot water taps.
- Turn off gas supply and 120 V power supply.
- Remove manometer and re-install allen head plug.
- Turn on the gas supply and 120 V power supply.
- Operate the unit and check for gas leaks.
- Install the front panel using four screws.

WARNING Do not put dip switches 2 and 3 (white switches) in on position. These settings are only for commercial applications and are not compatible with V75i.

Diagnostic Use of the Controller

- To display the most recent diagnostic codes press and hold the "On/Off" button for 2 seconds on the MC-91 controller.
- To enter or exit the maintenance monitor information mode press and hold the down button for 2 seconds and without releasing it press the ON/OFF button.

No.	Data	Unit
01	Water flow rate	0.1 gal/min
02	Outgoing water temperature	Degrees Fahrenheit

To Change the Temperature Scale (°F / °C)

With the water heater turned off, press and hold the ON/OFF button until the display changes to the other temperature scale (about 5 seconds).

To Turn Off the Controller Sound (Mute)

To turn the sound off (mute), press and hold both the ▲ and ▼ thermostat buttons until a "beep" is heard (about 5 seconds).

Locking the Controller

The MC-91-2 controller can be locked or unlocked by pressing the Priority button and the up button together for 5 seconds. A beep will sound confirming that the controller is locked. The display will alternately show "LOC", the temperature setting, and a diagnostic code if one has been activated. All of the controllers in the system are also locked.

To unlock the controller press the Priority button and the up button together for 5 seconds.

Gas Pressure Setting

NOTE: For additional installation and commissioning information refer to the Operation and Installation Manual.

WARNING This appliance must be installed, serviced and removed by a trained and qualified person. During pressure testing of the consumer piping, ensure gas valve is turned off before unit is shut off. Failure to do so may result in serious injury to yourself or damage to the unit.

APPLIANCE OPERATING PRESSURES

Table 1

V75i	Short flue length Long flue length	Water Inlet Max. 150 PSI	Gas Inlet Min./Max.		Forced Low		Forced High	
			NAT.G 5"W.C. /10.5"W.C.	LPG 8"W.C. /13.5"W.C.	NAT.G 0.61"W.C.	LPG 0.87"W.C.	NAT.G 2.5"W.C.	LPG 3.9"W.C.
					0.61"W.C.	0.95"W.C.	2.3"W.C.	3.7"W.C.

Commissioning

With all gas appliances in operation at maximum gas rate, the flowing inlet pressure at the incoming test point on the Rinnai water heater should read 5" W.C. - 10.5" W.C. on natural gas and 8" W.C. - 13.5 W.C. on propane gas. If the pressure is lower, the gas supply is inadequate and the unit will not operate to specification. Check the gas meter regulator and pipework for correct operation/sizing and correct as required.

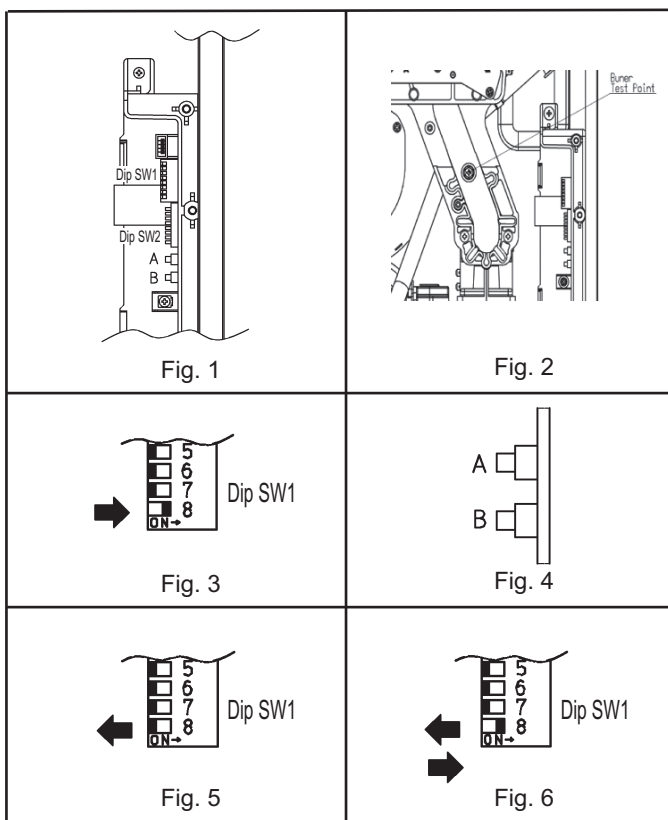

Diagnostic Codes

03 Power interruption during Bath fill (Water will not flow when power returns)

- Turn off all hot water taps. Press ON/OFF twice.

10 Air Supply or Exhaust Blockage

- Ensure approved venting materials are being used.
- Check that nothing is blocking the flue inlet or exhaust.
- Check all vent components for proper connections.
- Ensure vent length is within limits.
- Verify dip switches are set properly.
- Check fan for blockage.

11 No Ignition

- Check that the gas is turned on at the water heater, meter, or cylinder.
- If the system is propane, make sure that gas is in the tank.
- Ensure appliance is properly grounded.
- Ensure gas type and pressure is correct.
- Ensure gas line, meter, and/or regulator is sized properly.
- Bleed all air from gas lines.
- Verify dip switches are set properly.
- Ensure igniter is operational.
- Check igniter wiring harness for damage.
- Check gas solenoid valves for open or short circuits.
- Remove burner cover and ensure burners are properly seated.
- Remove burner plate; inspect burner surface for condensation/debris.

12 No Flame

- Check that the gas is turned on at the water heater, meter, or cylinder.
- Check for obstructions in the flue outlet.
- If the system is propane, make sure that gas is in the tank.
- Ensure gas line, meter, and/or regulator is sized properly.
- Ensure gas type and pressure is correct.
- Bleed all air from gas lines.
- Ensure proper venting material was installed.
- Ensure condensation collar was installed properly.
- Ensure vent length is within limits.
- Verify dip switches are set properly.
- Check power supply for loose connections.
- Check power supply for proper voltage and voltage drops.
- Ensure flame rod wire is connected.
- Check flame rod for carbon build-up.
- Disconnect and reconnect all wiring harnesses on unit and PC board.
- Check for DC shorts at components.
- Check gas solenoid valves for open or short circuits.
- Remove burner plate; inspect burner surface for condensation/debris.
- Check the ground wire for the PC board.

14 Thermal Fuse

- Check for restrictions in air flow around unit and vent terminal.
- Check gas type of unit and ensure it matches gas type being used.
- Check for low water flow in a circulating system causing short-cycling.
- Ensure dip switches are set to the proper position.
- Check for foreign materials in combustion chamber and exhaust piping.
- Check heat exchanger for cracks or separations.
- Check heat exchanger surface for hot spots which indicate blockage due to scale build-up. Refer to instructions in manual for flushing heat exchanger. Hard water must be treated to prevent scale build up or damage to the heat exchanger.
- Measure resistance of safety circuit.
- Ensure high fire and low fire manifold pressure is correct.
- Check for improper conversion of product.

16 Over Temperature Warning

- Check for restrictions in air flow around unit and vent terminal.
- Check for low water flow in a circulating system causing short-cycling.
- Check for foreign materials in combustion chamber and exhaust piping.
- Check for blockage in the heat exchanger.

19 Electrical Grounding

- Check all components for electrical short.

32 Outgoing Water Temperature Sensor

33 Heat Exchanger Outgoing Temperature Sensor

34 Combustion Air Temperature Sensor Fault

- Check for restrictions in air flow around unit and vent terminal.
- Check sensor wiring for damage.
- Measure resistance of sensor.
- Clean sensor of scale build up.
- Ensure fan blade is tight on motor shaft and is in good condition.
- Replace sensor.

52 Modulating Solenoid Valve Signal

- Check modulating gas solenoid valve wiring harness for loose or damaged terminals.
- Measure resistance of valve coil.

61 Combustion Fan

- Ensure fan will turn freely.
- Check wiring harness to motor for damaged and/or loose connections.
- Measure resistance of motor winding.

65 Water Flow Servo

- Check water flow control valve has failed to close during the bath fill function. Immediately turn off the water and discontinue the bath fill function. Contact a licensed professional.

70 PC Board

- Check PC board DIP switches for correct positions.
- Check the connection harness at the connection on the PC board.
- Replace PC board.

71 Solenoid Valve Circuit

- Replace the PC Board.

72 Flame Sensing Device

- Verify flame rod is touching flame when unit fires.
- Check all wiring to flame rod.
- Remove flame rod; check for carbon build-up; clean with sand paper.
- Check inside burner chamber for any foreign material blocking flame at flame rod.
- Measure micro amp output of sensor circuit with flame present.
- Replace flame rod.

79 Water leakage detected

- Turn off water supply and contact licenced professional.

LC# Scale Build-up in Heat Exchanger (when checking maintenance code history "00" is substituted for "LC")

- LC0-LC9 indicates that there is scale build up in the heat exchanger, and that the heat exchanger needs to be flushed to prevent damage. Refer to the flushing instructions in the manual. Hard water must be treated to prevent scale build up or damage to the heat exchanger.
- To operate the water heater temporarily until the heat exchanger can be flushed, push the On/Off button on the temperature controller 5 times. Repeated LC# codes will eventually lock out the water heater.

FF Maintenance Performed

- Indicates a service provider performed maintenance or repair. Enter this code by pressing up, down, and ON/OFF simultaneously.

No Code (Nothing happens when water flow is activated.)

- Clean inlet water supply filter.
- On new installations ensure hot and cold water lines are not reversed.
- Verify you have at least the minimum flow rate required for fire unit.
- Check for cold to hot cross over. Isolate circulating system if present.
- Turn off cold water to the unit, open pressure relief valve; if water continues to flow, there is bleed over in your plumbing.
- Verify turbine spins freely.
- Measure the resistance of the water flow control sensor.
- If the display is blank and clicking is coming from the unit, disconnect the water flow servo motor (GY, BR, O, W, P, BL, R). If the display comes on then replace the water flow servo motor.

Troubleshooting

Important Safety Notes

There are a number of (live) tests that are required when fault finding this product. Extreme care should be used at all times to avoid contact with energized components inside the water heater. Only trained and qualified service technicians should attempt to repair this product. Before checking for resistance readings, disconnect the power source to the unit and isolate the item from the circuit (unplug it).

(SV1, SV2, SV3, SV4 and POV) Gas valve and Modulating solenoids: (Set meter above 2K)

Wire color	Voltage	Resistance	Connector #	Pin #'s
(Main) Black - Grey	11 ~ 13 VDC	24 ~ 28 ohms	D1	B3 - B4
(SV1) Black - Blue	11 ~ 13 VDC	36 ~ 42 ohms	B3	4 - 6
(SV2) Black - Yellow	11 ~ 13 VDC	36 ~ 42 ohms	B2	4 - 7
(SV3) Black - Red	11 ~ 13 VDC	36 ~ 42 ohms	B4	4 - 5
(SV4) Black - Orange	11 ~ 13 VDC	35 ~ 41 ohms	B1	4 - 8
(POV) Pink - Pink	2 ~ 15 VDC	67 ~ 81 ohms	D1	1 - 2

(M) Water Flow Control Device Servo or Geared Motor:

Red - Pink	5 ~ 8 VDC	44 ~ 52 ohms	G2	3 - 4
White - Blue	5 ~ 8 VDC	44 ~ 52 ohms	G2	1 - 2
Grey - Brown	N/A	N/A	G2	5 - 7
Grey - Orange	N/A	N/A	G2	6 - 7

NOTE: The grey wire listed above turns to black at G connector on the PCB.

(QS) Water Flow Sensor:

Black - Red	11 ~ 13 VDC	5.5 ~ 6.2 K ohms	L3	E10 - G7
Yellow - Black	4 ~ 7 VDC	1 ~ 1.4 Mega ohms	L3	E1 - G7

By-pass Flow Control:

Red - Pink	2 ~ 6 VDC	44 ~ 52 ohms	G1	12 - 13
White - Blue			G1	10 - 11

(IG) Ignition System:

Grey - Grey	90 ~ 110 VAC	N/A	C1	1 - 3
-------------	--------------	-----	----	-------

(FM) Combustion Fan Motor:

Red - Black	6 ~ 45 VDC	N/A	L2	5 - 6
White - Black	5 ~ 10 VDC	N/A	L2	3 - 5
Yellow - Black	11 ~ 13 VDC	N/A	L2	4 - 5

Set your meter to the hertz scale. Reading across the white and black wires at terminals 3 and 5 you should read between 60 and 420 hertz.

Thermal Fuse / Overheat Switch:

White - White	11 ~ 13 VDC	Below 1 ohms	B8 B7	B1 - E10
---------------	-------------	--------------	----------	----------

Flame Rod:

Place one lead of your meter to the flame rod and the other to ground. With the unit running you should read between 5-150 VAC. Set your meter to the µ amp scale and series your meter in line with the flame rod. You should read 1 µ amp or greater for proper flame circuit. In the event of low flame circuit remove the flame rod and check for carbon or damage.

Heat Exchanger, Outgoing Water Temperature and Inlet Thermistors:

Check all thermistors by inserting meter leads into each end of the thermistor plug. Set your meter to the 20 K scale and read resistance. Applying heat to the thermistor bulb should decrease the resistance. Applying ice to the thermistor bulb should increase the resistance. See below for examples of typical temperatures and resistance readings.

Example: 59°F = 11.4 ~ 14KΩ 140°F = 2.2 ~ 2.7KΩ
86°F = 6.4 ~ 7.8KΩ 221°F = 0.6 ~ 0.8KΩ
113°F = 3.6 ~ 4.5KΩ

Outgoing Water Thermistor:

White - White	N/A	See example above	E5	2 - 3
Blue - Blue	N/A	See example above	E5	4 - 5

Heat Exchanger Temperature Thermistor:

Pink - Pink	N/A	See example above	E4	4 - 7
-------------	-----	-------------------	----	-------

Inlet Thermistor:

White - White	N/A	See example above	E7	4 - 9
---------------	-----	-------------------	----	-------

Remote Controls:

Terminals J	10 ~ 13 VDC	1.5 ~ 3.0 K ohms	J	1 - 2
-------------	-------------	------------------	---	-------

Frost Protection:

This unit has frost protection heaters mounted at different points to protect the water heater from freezing. All of them should show a positive resistance reading.

Amp Fuses:

This unit has one inline (10) amp glass fuse. Remove the fuse and check continuity through it. If you have continuity through the fuse then it is good. Otherwise the fuse is blown and must be replaced.

Wire Diagram

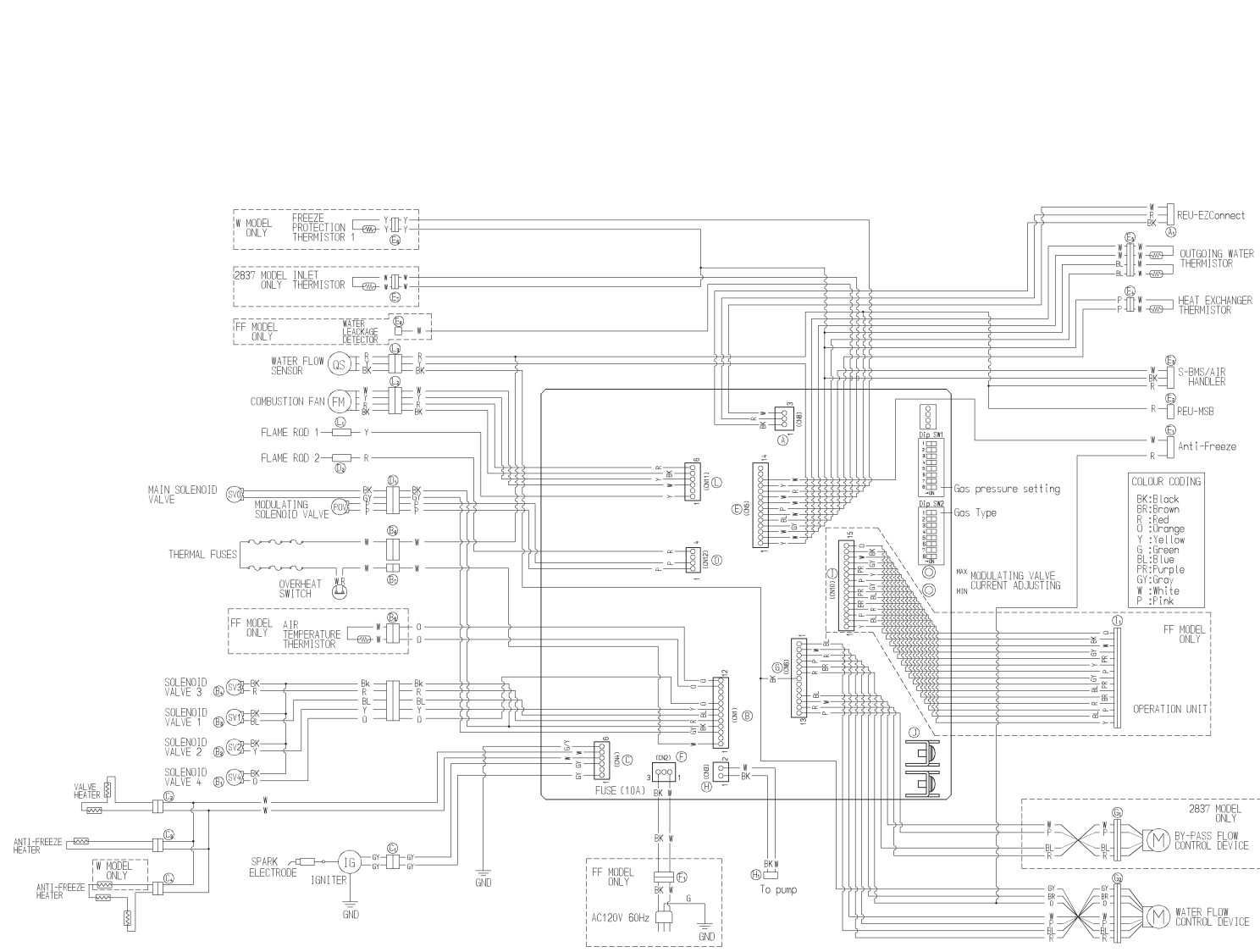

Dip Switches Settings

Adjust switches 2 and 3 of Dip SW1 (upper side) depending on your altitude according to the table below.

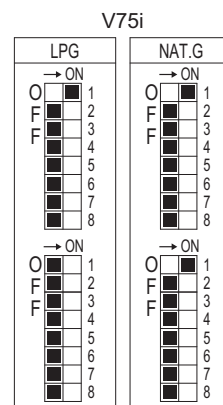

WARNING

DO NOT adjust the other dip switches unless specifically instructed to do so. Incorrect Dip Switch Settings can cause the Rinnai water heater to operate in an unsafe condition and may damage the water heater and void the warranty.

Dip SW No.	NOTES								
2	High Altitude	Off	Level 0 0-2000 ft (0-610 m)	Off	Level 1 2001-5200 ft (610-1585 m)	On	Level 2 5201-7700 ft (1585-2347 m)	On	Level 3 7701-10200 ft (2347-3109 m)
3		Off		On		On			



070 00012 35670 9

V75i (VC2528FFU-US)

U307-1110(01)

EXPLODED VIEW - CABINET

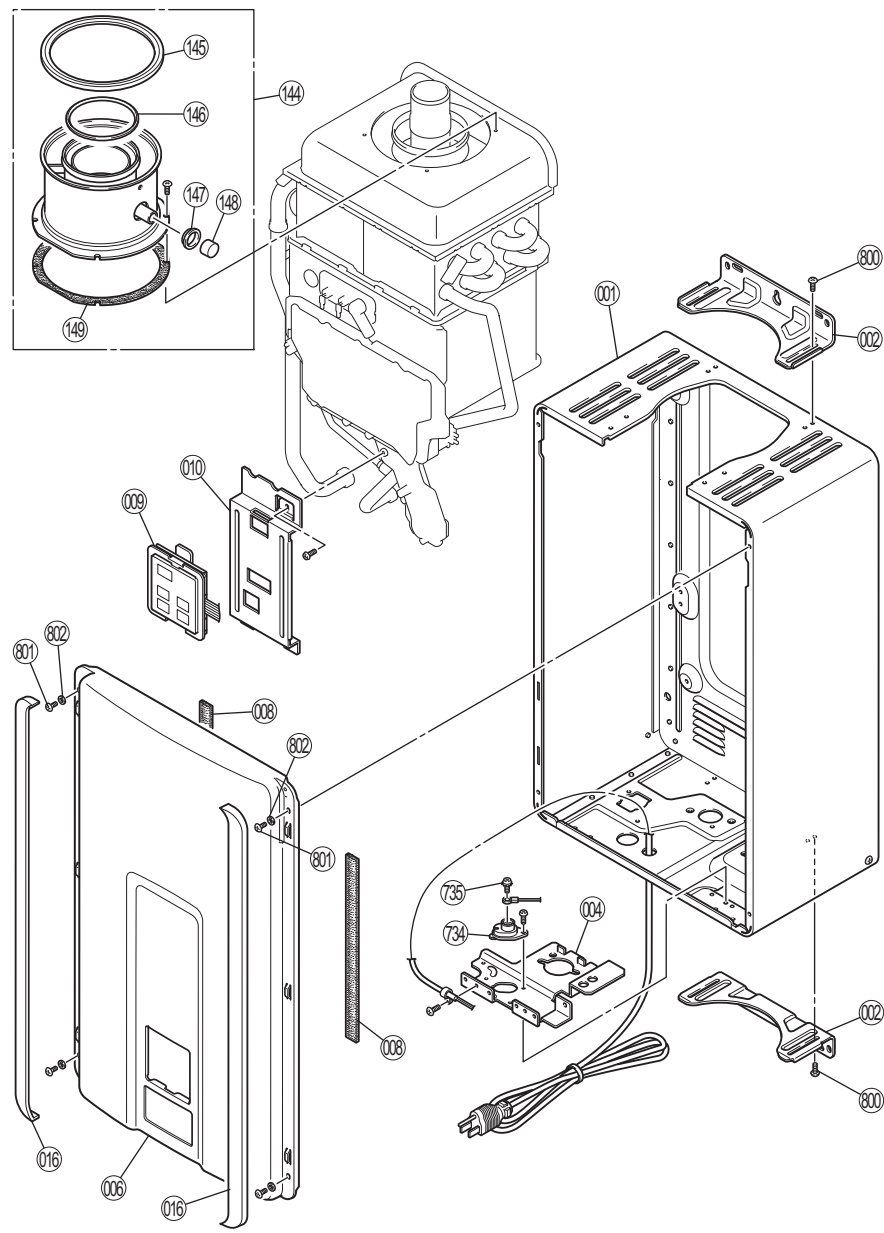

EXPLODED VIEW - INTERNALS

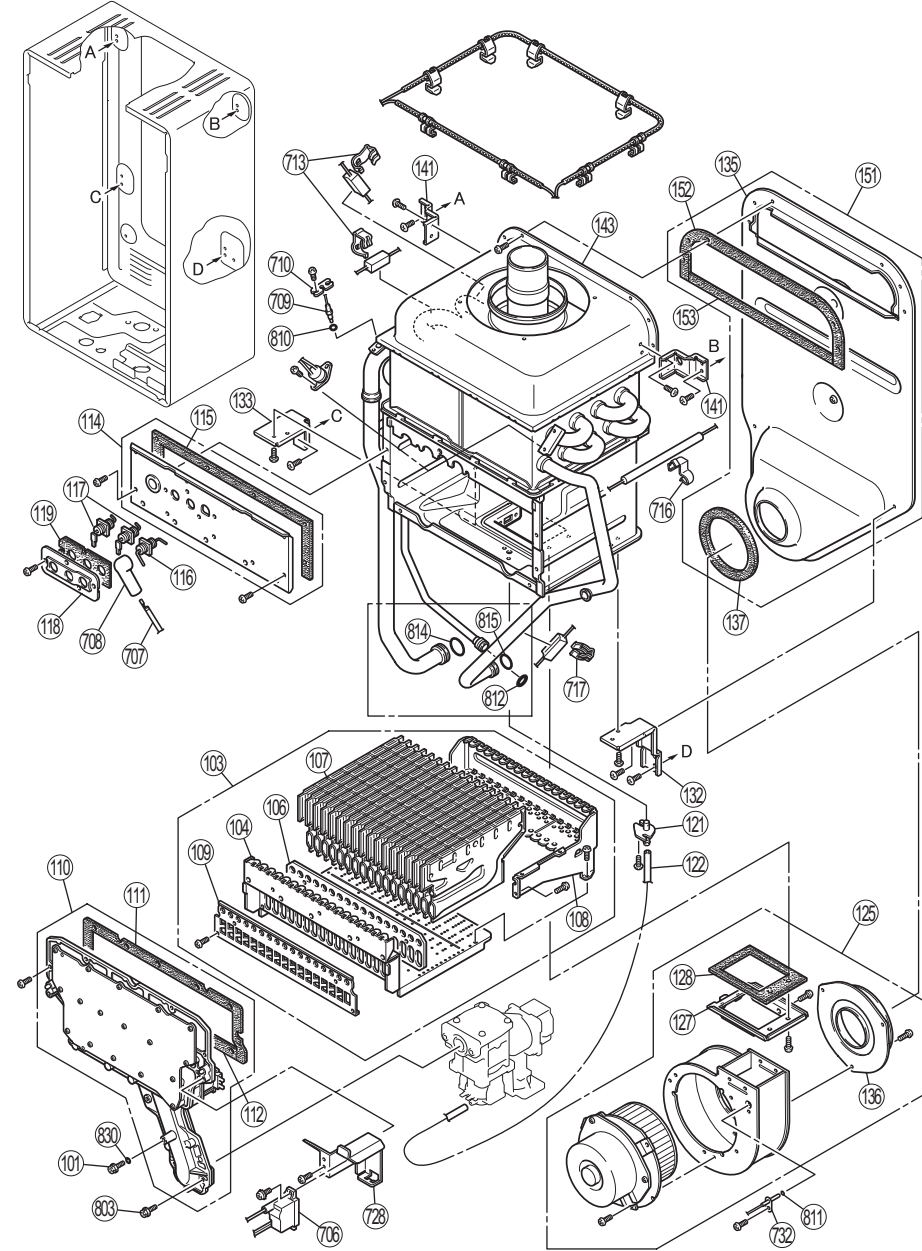

EXPLODED VIEW - INTERNALS

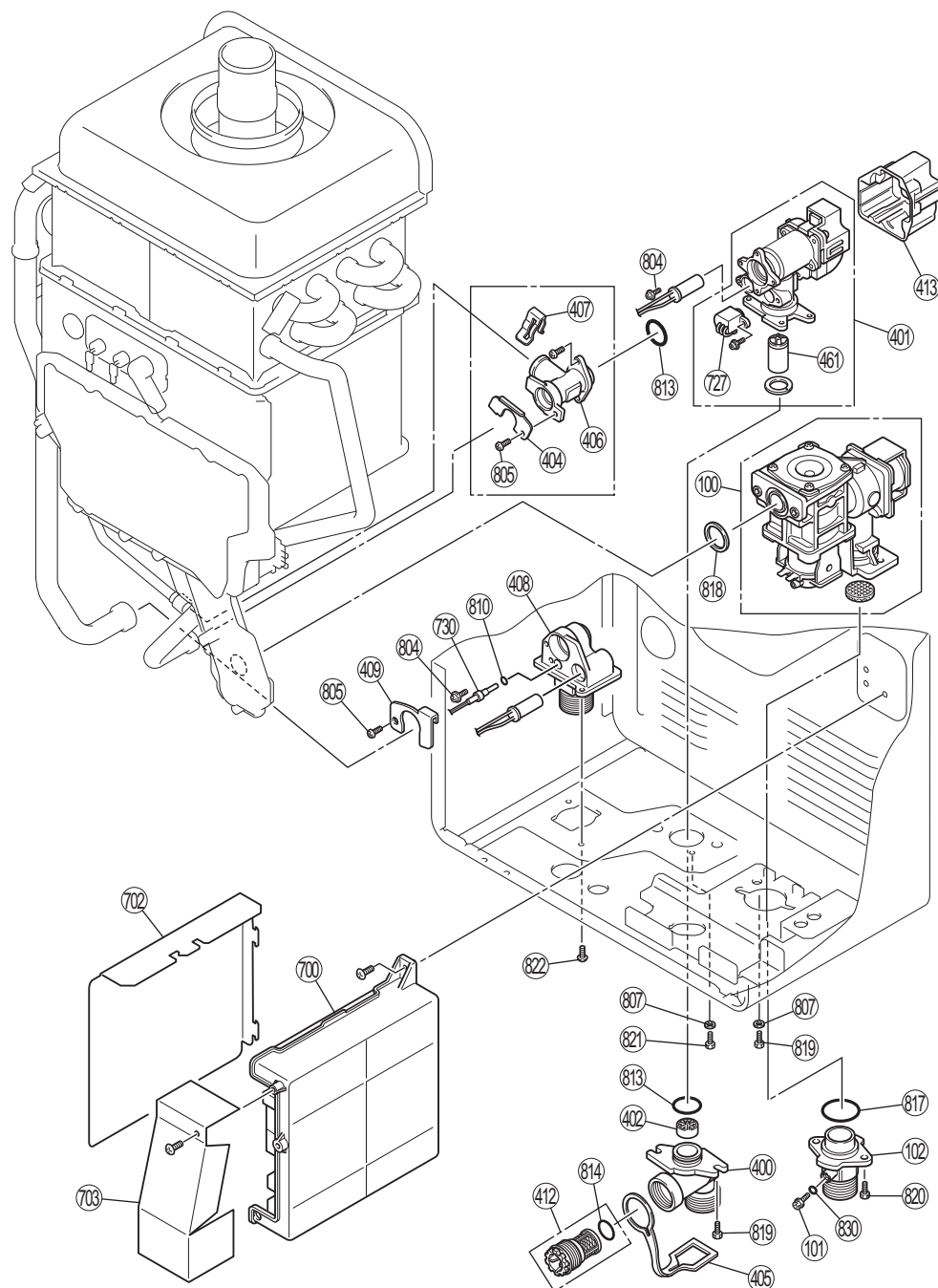

EXPLODED VIEW - ELECTRICAL

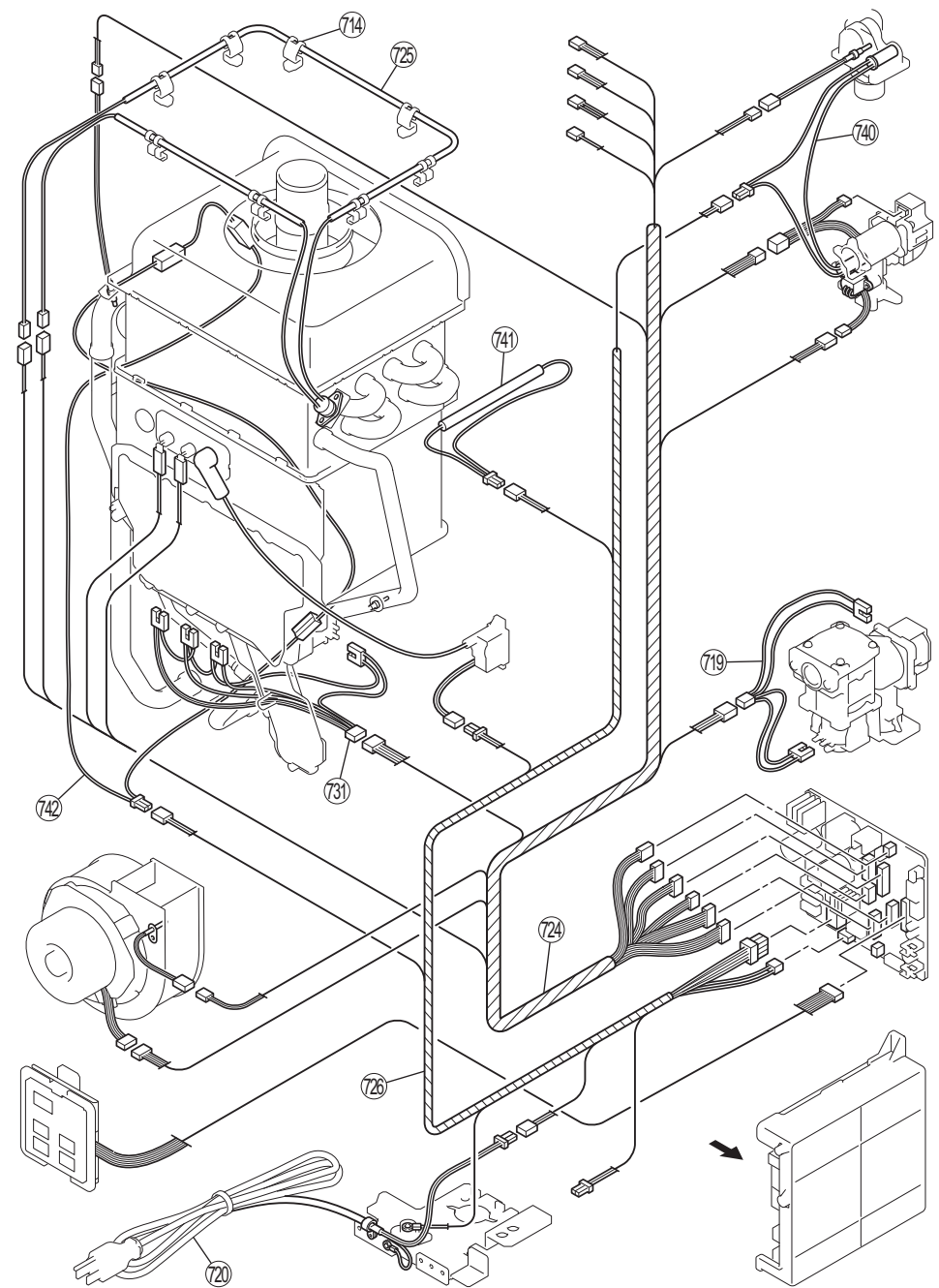

Item Description	Part Number	V75i Qty (VC2528)
001 MAIN BODY	109000289	1
002 WALL BRACKET	109000259	2
004 CONNECTION REINFORCEMENT	109000261	1
006 FRONT PANEL	109000295	1
008 FRONT PANEL PACKING	U245-3185-2	2
009 TEMPERATURE CONTROL	105000188	1
010 TEMPERATURE CONTROL PLATE	109000263	1
016 SCREW COVER	109000294	2
100 GAS CONTROL ASSEMBLY	106000085	1
101 TEST PORT SET SCREW	C10D-5	2
102 3/4 GAS INLET	106000065	1
103 BURNER UNIT ASSY (LPG)	106000072	1
103 BURNER UNIT ASSY (NG)	106000073	1
104 BURNER CASE FRONT PANEL	106000074	1
106 PACKING	109000264	1
107 BURNERS	106000054	17
108 BURNER CASE BACK PANEL	106000075	1
109 DAMPER(LPG)	106000076	1
109 DAMPER (NG)	106000077	1
110 MANIFOLD ASSEMBLY (LPG)	106000078	1
110 MANIFOLD ASSEMBLY (NG)	106000079	1
111 COMB CHAMBER PACKING UPPER	106000080	1
112 COMB CHAMBER PACKING LOWER	106000081	1
114 COMB CHAMBER FRONT PANEL	106000082	1
115 COMB CHAMBER PACKING - 2	106000083	1
116 ELECTRODE	105000179	1
117 FLAME ROD	105000093	2
118 ELECTRODE BRACKET	105000156	1
119 ELECTRODE PACKING	105000157	1
121 BACK PRESSURE CONNECTOR	U242-312	1
122 TUBE G	109000198	1
125 FAN MOTOR ASSEMBLY	108000061	1
127 FAN CONNECTING BRACKET	108000062	1
128 FAN CONNECTING BRACKET PACKIN	108000063	1
132 HEAT EXCHANGER BRACKET	109000265	1
133 HEAT EXCHANGER BRACKET	109000266	1
135 AIR INLET	108000064	1

Item Description	Part Number	V75i Qty (VC2528)
136 FAN BRACKET	109000267	1
137 SEAL PACKING	109000268	1
141 HEAT EXCHANGER BRACKET	109000269	2
143 HEAT EXCHANGER ASSEMBLY	107000101	1
144 FLUE CONNECTION ASSEMBLY	108000068	1
145 INLET SEAL	109000239	1
146 O-RING	108000018	1
147 PIPE SEAL	109000170	1
148 CAP	109000171	1
149 PACKING	109000240	1
151 AIR INLET ASSEMBLY	108000069	1
152 DUCT PACKING UPPER	108000070	1
153 DUCT PACKING LOWER	108000071	1
400 WATER INLET	H73-501-2	1
401 WATER FLOW SERVO & SENSOR	107000090	1
402 RECTIFIER	M8D1-15	1
404 PIPE BRACKET	AH69-310	1
405 PLUG BAND	109000018	1
406 FIXED BYPASS	107000103	1
407 CLIP	109000278	1
408 HOT WATER OUTLET (3/4 NPT)	107000104	1
409 STOP BRACKET	AU162-1876	1
412 FILTER ASSEMBLY	H98-510-S	1
413 COVER	107000093	1
461 WATER FLOW TURBINE	107000088	1
700 PC BOARD	105000160	1
702 COVER	109000247	1
703 EC COVER	109000248	1
706 IGNITOR	105000180	1
707 HIGH TENSION CORD	BH38-710-240	1
708 ELECTRODE SLEEVE	AU206-218	1
709 THERMISTOR	105000114	1
710 RETAINER (THERMISTOR)	CP-90172	1
713 HEATER CLIP	109000270	2
714 FUSE HOLDER	U250-670X01	8
716 HEATER CLIP	109000271	2
717 HEATER CLIP	AU100-721	1
719 MAIN SOLENOID HARNESS	105000162	1

Item Description	Part Number	V75i Qty (VC2528)
720 POWER CORD ASSEMBLY	CP-90580	1
724 SENSOR HARNESS-3	105000165	1
725 FUSE HARNESS	105000167	1
726 POWER SUPPLY HARNESS	105000184	1
727 WATER FLOW SENSOR	105000176	1
728 IGNITOR BRACKET	109000272	1
730 TWIN THERMISTOR	105000108	1
731 SOLENOID HARNESS	105000168	1
732 INLET AIR THERMISTOR	105000029	1
734 SENSOR BRACKET	109000273	1
735 SCREW	109000279	1
740 HEATER	105000154	1
741 HEATER	105000169	1
742 HEATER	105000171	1
800 TRUSS SCREW	CP-30580-2	8
801 TRUSS SCREW	CP-30580	4
802 NYLON WASHER	AU33-184X01	4
803 SCREW	109000280	2
804 SCREW	U217-449	2
805 SCREW	CP-20883-410UK	2
807 PLASTIC WASHER	AU48-174	2
810 O-RING	M10B-2-4	2
811 O-RING	M10B-2-3	1
812 O-RING	M10B-2-10	1
813 O-RING	M10B-2-18	2
814 O-RING	M10B-2-16	2
815 O-RING	M10B-2-14	1
817 O-RING	M10B-1-24	1
818 PACKING	109000181	1
819 HEXAGON HEAD SCREW	ZQAA0512UK	3
820 HEXAGON HEAD SCREW	ZQAA0514UK	2
821 HEXAGON HEAD SCREW	ZQAA0508UK	1
822 SCREW	CP-30580	2
830 O-RING	M10B-13-4	2
888 MANUAL	100000258	1
889 TECH SHEET	100000260	1