

# MODEL XN110 VENTILATION FAN

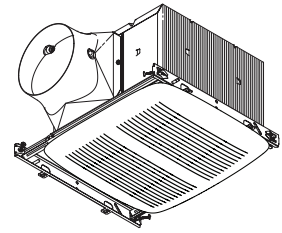

### FEATURES

#### ULTRASMART™ DC Motor and Control Technology

- DC motor for efficiency well beyond ENERGY STAR® requirements.
- Can be used to comply with ASHRAE 62.2, LEED, ENERGY STAR® for Homes and CA Title 24.
- Powerful operation maintained over a wide range of real-world installations (CFM ratings maintained through at least 0.25" static pressure).
- Rated for Continuous Operation.

#### ULTRASILENT™ Sound Technology

- HVI certified, best-achievable <0.3 Sone level provides nearly silent operation for a relaxing environment.
- State-of-the-art blower and duct outlet design smooths airflow.
- High tech DC motor designed for nearly silent operation.

#### ULTRAQUICK™ Installation Technology

- Unique telescoping mounting frame fits through retrofit drywall opening to allow easy installation from the room side. No attic access needed!
- Captive screws allow for easy new construction installation.
- Mounting frame positioning tabs provide easy vertical positioning for new construction.
- Easy to insert and remove snap-in housing. No screws required!
- Easy to insert and remove snap-in blower.
- Inside or outside duct connector and knockout plate mounting provides flexibility for new construction or retrofit.

U.L. Listed for use over bathtubs and showers when connected to a GFCI protected branch circuit (ceiling mount only).

Use only ON/OFF switch, mechanical timer or relay-switched control.

3-year warranty.

### DIMENSIONS (Inches)

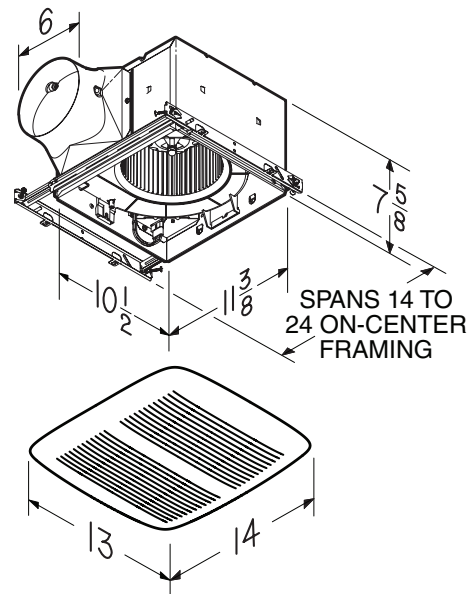

Broan-NuTone LLC Hartford, Wisconsin www.nutone.com 888-336-3948

REFERENCE	QTY.	REMARKS	Project
			Location
			Architect
			Engineer
			Contractor
			Submitted by <span style="float: right;">Date</span>

### HVI PERFORMANCE

6" Duct				
0.1 Ps - Static Pressure (inH2O)				0.25 Ps
Airflow (CFM)	Sound (Sones)	Power (Watts)	Efficacy (CFM/Watt)	Airflow (CFM)
110	< 0.3	7.7	14.2	110



HVI-2100 CERTIFIED RATINGS comply with new testing technologies and procedures prescribed by the Home Ventilating Institute, for off-the-shelf products, as they are available to consumers. Product performance is rated at 0.1 in. static pressure, based on tests conducted in a state-of-the-art test laboratory. Sones are a measure of humanly-perceived loudness, based on laboratory measurements.

### ELECTRICAL & WEIGHT

Volts	Hz	Amps	Shipping Weight (lbs.)
120	60	0.2	12.3



XN110 - 6" DUCT

