

# MUELLER® NO-BLO® FORGED STEEL SERVICE TEE FEATURES

**Mueller Co.**

Reliable Connections™

# 3.1

Shaded area indicates change Rev. 12-06

Mueller NO-BLO Service Tees are used to make main to service connections. These tees are available in a wide range of sizes and inlet and outlet combinations.

The threaded inlet tees can be used with Mueller Service Saddles to make main to service connections that do not require welding.

The tees are available with either weld or external (M.I.P.) thread inlets.

Outlets include weld, thread (M.I.P. or F.I.P.) and compression connections.



- COMPLETION CAP – is available in Cast Iron or steel for most tees and provides a secondary seal.
- MAXIMUM WORKING PRESSURE – 250 psig for tees with Cast Iron caps and 1440 psig for tees with steel caps. Tees with compression connection outlets have lower pressure ratings.
- COMPLETION PLUG – makes primary seal.
- OUTLETS – are available in weld, external (M.I.P.) thread, internal (F.I.P.) thread, and several popular compression connections.
- BODY – is machined from solid steel forging for strength.
- INLETS – are available in either weld or external (M.I.P.) thread styles.

Mueller NO-BLO Transition Service Tees are designed to give you dependable connections from steel gas mains to plastic service lines. These tees are available in a wide range of sizes and inlet and outlet combinations.

Because our transition tees are assembled and permanently joined under controlled conditions, much of the potential for human error is eliminated, with no loose parts or on-site assembly required during installation.

### Mueller Transition Tee Features

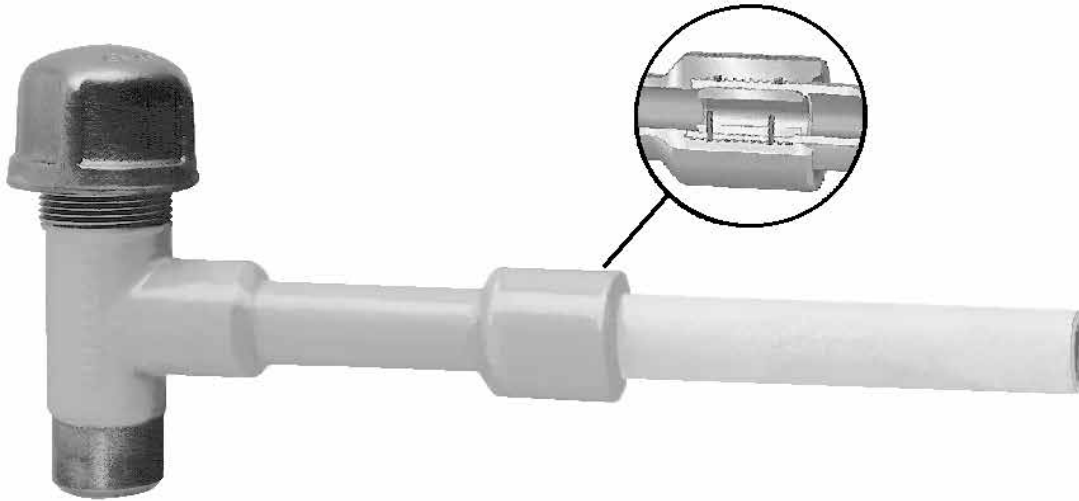

- COMPLETION CAPS – are available in Cast Iron and provide a secondary seal.
- TRANSITION CONNECTION – exceeds the hydrostatic burst pressure and tensile strength of polyethylene pipe.
- MULTIPLE PIGTAIL CHOICES – available in medium or high density polyethylene pigtails in CTS or IPS pipe sizes. Extra pigtail length allows more than one fusion connection attempt if needed.
- FUSION EPOXY COATING – resists corrosion.
- FORGED STEEL BODY – ensures long-term strength and structural integrity.
- CONFORMS TO ASTM D638 and DOT192.283.

# MUELLER® NO-BLO® SERVICE TEE WELD x WELD - 250 PSIG

**Mueller Co.**

Reliable Connections™

**3.3**

Shaded area indicates change Rev. 6-10

- Catalog number – **H-17500**
- Sizes\* – 3/4" x 3/4", 1" x 1", 1-1/4" x 1-1/4", 2" x 2"
- Forged Steel Body ASTM A105
- Cast Iron Completion Cap ASTM A126 CL.B
- Brass Completion Plug - 3/4" x 3/4", 1" x 1", 1-1/4" x 1-1/4"
- Cast Iron Completion Plug - 2" x 2"
- Weld inlet
- Outlet prepared for butt weld same size as outlet and socket weld one size smaller than outlet
- 250\*\* psig (1724 kPa)



**H-17500**

## How to select equipment

- 1) Find chart on following pages containing desired combination of fitting and installation machine (shown in bold type at top of each page and chart). Note: for a given fitting there may be more than one machine and chart.
- 2) Under inlet size of fitting to be installed, select catalog number for type of control valve to be used. Options may include one or more of the following: H-10914 Bronze Gate Valve, H-17025 Control Chamber, H-10917 Slide Gate Valve, H-10918 Steel Ball Valve.
- 3) Under selected control valve, column lists equipment necessary for each operation on chosen size of fitting. Note: **MAOP** (Maximum Allowed Operating Pressure) provided for **each** operation must not be exceeded. MAOP may be different for each operation.

## Dimensions

Dimensions	Size* of Service Tee			
	3/4" x 3/4"	1" x 1"	1-1/4" x 1-1/4"	2" x 2"
A	4"	4-1/8"	4-5/8"	5-1/2"
B	1-3/4"	1-7/8"	2"	2-1/8"
C	1"	1-1/4"	1-1/2"	2"
D	1/2"	3/4"	1"	1-1/2"

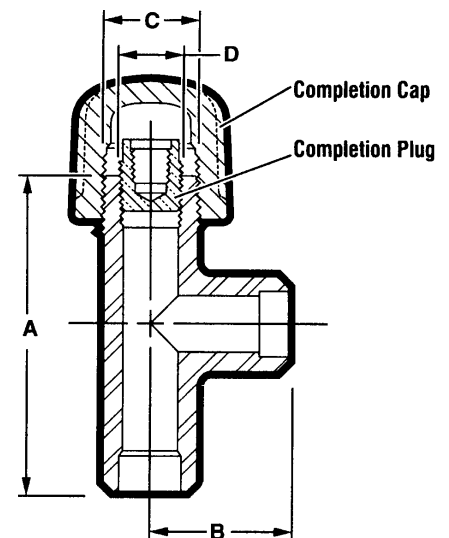

## Replacement Parts

Replacement Parts	Size* of Service Tee			
	3/4" x 3/4"	1" x 1"	1-1/4" x 1-1/4"	2" x 2"
Completion Cap	34061	37483	38138	36310
Completion Plug	78898	34060	34122	36356

\*First size is size of inlet, second is size of outlet.

\*\*This is the maximum pressure of the fitting installed in the line at 100F for Class Locations 1, 2, 3 and 4 as defined in D.O.T./CFR TITLE 49 PART 192. It may be necessary to reduce the line pressure during the drilling, stopping or plugging operations to the maximum working pressure of the machine or its attachments. Refer to charts on following pages.

Rev. 12-06 Shaded area indicates changes

**E-5™/EH-5™ Machine**

H-17500	3/4"	3/4"	3/4"	1"	1"	1"
Control Valve	H-10914 1-1/4"	H-17025	H-10918 1-1/4"	H-10914 1-1/4"	H-17025	H-10918 1-1/4"
Bushing	-	78829 1"	-	-	78830 1-1/4"	-
<b>Installation</b>						
Center Locating Punch	H-17615	H-17615	H-17615	H-17615	H-17615	H-17615
Test Cap	79159	79159	79159	79160	79160	79160
Completion Plug Wrench	96536	96536	96536	96536	96536	96536
<b>Drilling</b>						
<b>MAOP*</b>	125 psig	125 psig	250 psig	125 psig	125 psig	250 psig
Power Operator	H-604	H-604	H-604	H-604	H-604	H-604
Machine Adapter	36733	-	36733	36733	-	36733
Reducing Bushing	36969 1-1/4" x 1"	-	36969 1-1/4" x 1"	-	-	-
Drill	61982 5/8"	61982 5/8"	61982 5/8"	-	-	-
Drill Holder	61981	61981	61981	-	-	-
Combined Drill and Holder	-	-	-	79185 3/4"	79185 3/4"	79185 3/4"
Cutting Grease	88366	88366	88366	88366	88366	88366
Honing Stone	682560	682560	682560	682560	682560	682560
<b>Stopping</b>						
<b>MAOP†</b>	125 psig	125 psig	250 psig	125 psig	125 psig	250 psig
Machine Adapter	36733	-	36733	36733	-	36733
Reducing Bushing	36969 1-1/4" x 1"	-	36969 1-1/4" x 1"	-	-	-
Steel Shut Off Tool	45628	45628	45628	36197	36197	36197
Rubber Shut Off Tool	88757	88757	88757	88125	88125	88125
Replacement Rubber	37454	37454	37454	37629	37629	37629
Holder for Rubber Shut Off Tool	61981	63396	61981	61789	61789	61789
Rubber Stopper Lubricant	580657	580657	580657	580657	580657	580657
<b>Inserting</b>						
<b>MAOP*</b>	125 psig	125 psig	250 psig	125 psig	125 psig	250 psig
Machine Adapter	36733	-	36733	36733	-	36733
Reducing Bushing	36969 1-1/4" x 1"	-	36969 1-1/4" x 1"	-	-	-
EZ Release Inserting Tool	83261	83261	83261	83261	83261	83261
<b>Extracting</b>						
<b>MAOP*</b>	125 psig	125 psig	250 psig	125 psig	125 psig	250 psig
Machine Adapter	36733	-	36733	36733	-	36733
Reducing Bushing	36969 1-1/4" x 1"	-	36969 1-1/4" x 1"	-	-	-
Extracting Tool	80088	80088	80088	80088	80088	80088
Extracting Tool Adapter	-	-	-	-	-	-

\*Maximum Allowable Operating Pressure

†In stopping section of chart, Maximum Allowable Operating Pressure (MAOP) applies to use of rubber shut off tool only. For steel shut off tool, variables in hole drilled in pipe may or may not allow similar MAOP.

**E-5™/EH-5™ Machine**

<b>H-17500</b>	<b>1-1/4"</b>	<b>1-1/4"</b>	<b>1-1/4"</b>	<b>2"</b>	<b>2"</b>	<b>2"</b>
Control Valve	H-10914 1-1/2"	H-17025	H-10918 1-1/2"	H-10914 2"	H-10917 2"	H-10918 2"
Bushing	-	78831 1-1/2"	-	-	-	-
<b>Installation</b>						
Center Locating Punch	H-17615	H-17615	H-17615	-	-	-
Test Cap	79161	79161	79161	36811	36811	36811
Completion Plug Wrench	96536	96536	96536	581264	581264	581264
<b>Drilling</b>						
<b>MAOP*</b>	125 psig	125 psig	250 psig	125 psig	250 psig	250 psig
Power Operator	H-604	H-604	H-604	H-604	H-604	H-604
Machine Adapter	33575	-	33575	78907	78907	528329
Combined Drill and Holder	79186 1"	79186 1"	79186 1"	-	-	-
Shell Cutter	-	-	-	78910 1-1/2"	78910 1-1/2"	78910 1-1/2"
Shell Cutter Holder	-	-	-	78906	78906	501545
Cutter Holder Extension	-	-	-	-	-	63392
Cutting Grease	88366	88366	88366	88366	88366	88366
Honing Stone	682560	682560	682560	682560	682560	682560
<b>Stopping</b>						
<b>MAOP†</b>	125 psig	125 psig	250 psig	125 psig	250 psig	250 psig
Machine Adapter for Steel Shut Off Tool	33575	-	33575	78907	78907	528336
Steel Shut Off Tool	33570	33570	33570	78902	78902	78902
Machine Adapter for Rubber Shut Off Tool	33575	-	33575	78907	78907	528329
Rubber Shut Off Tool	88758	88758	88758	88773	88773	88773
Replacement Rubber	37459	37459	37459	37555	37555	37555
Holder for Rubber Shut Off Tool	61969	61969	61969	78906	78906	501545
Holder Extension for Rubber Shut Off Tool	-	-	-	-	-	63392
Rubber Stopper Lubricant	580657	580657	580657	580657	580657	580657
<b>Inserting</b>						
<b>MAOP*</b>	125 psig	125 psig	250 psig	125 psig	250 psig	250 psig
Machine Adapter	33575	-	33575	78907	78907	528329
EZ Release Inserting Tool	83261	83261	83261	83258	83258	83258
<b>Extracting</b>						
<b>MAOP*</b>	125 psig	125 psig	250 psig	125 psig	250 psig	250 psig
Machine Adapter	33575	-	33575	78907	78907	528329
Extracting Tool	80088	80088	80088	80087	80087	83262

\*Maximum Allowable Operating Pressure

†In stopping section of chart, Maximum Allowable Operating Pressure (MAOP) applies to use of rubber shut off tool only. For steel shut off tool, variables in hole drilled in pipe may or may not allow similar MAOP.

**D-5™/DH-5™ Machine**

<b>H-17500</b>	<b>3/4"</b>	<b>3/4"</b>	<b>1"</b>	<b>1"</b>
Control Valve	H-10914 1-1/4"	H-10918 1-1/4"	H-10914 1-1/4"	H-10918 1-1/4"
<b>Installation</b>				
Center Locating Punch	H-17615	H-17615	H-17615	H-17615
Test Cap	79159	79159	79160	79160
Completion Plug Wrench	96536	96536	96536	96536
<b>Drilling</b>				
<b>MAOP*</b>	125 psig	250 psig	125 psig	250 psig
Power Operator	H-604	H-604	H-604	H-604
Machine Adapter	36195	36195	36195	36195
Reducing Bushing	36969 1-1/4" x 1"	36969 1-1/4" x 1"	-	-
Drill	61982 5/8"	61982 5/8"	-	-
Drill Holder	36998	36998	-	-
Combined Drill and Holder	-	-	79185 3/4"	79185 3/4"
Boring Bar Adapter	-	-	36324	36324
Cutting Grease	88366	88366	88366	88366
Honing Stone	682560	682560	682560	682560
<b>Stopping</b>				
<b>MAOP†</b>	125 psig	250 psig	125 psig	250 psig
Machine Adapter	36195	36195	36195	36195
Reducing Bushing	36969 1-1/4" x 1"	36969 1-1/4" x 1"	-	-
Steel Shut Off Tool	45628	45628	36197	36197
Boring Bar Adapter**	36324	36324	36324	36324
Rubber Shut Off Tool	88757	88757	88125	88125
Replacement Rubber	37454	37454	37629	37629
Rubber Shut Off Holder	36998	36998	36915	36915
Rubber Stopper Lubricant	580657	580657	580657	580657
<b>Inserting</b>				
<b>MAOP*</b>	125 psig	250 psig	125 psig	250 psig
Machine Adapter	36195	36195	36195	36195
Reducing Bushing	36969 1-1/4" x 1"	36969 1-1/4" x 1"	-	-
EZ Release Inserting Tool	83261	83261	83261	83261
Boring Bar Adapter	36324	36324	36324	36324
<b>Extracting</b>				
<b>MAOP*</b>	125 psig	250 psig	125 psig	250 psig
Machine Adapter	36195	36195	36195	36195
Reducing Bushing	36969 1-1/4" x 1"	36969 1-1/4" x 1"	-	-
Extracting Tool	88286	88286	88286	88286

\*Maximum Allowable Operating Pressure

\*\*Only used with steel shut-off tool

†In stopping section of chart, Maximum Allowable Operating Pressure (MAOP) applies to use of rubber shut off tool only. For steel shut off tool, variables in hole drilled in pipe may or may not allow similar MAOP.

**D-5™/DH-5™ Machine**

<b>H-17500</b>	<b>1-1/4"</b>	<b>1-1/4"</b>	<b>2"</b>	<b>2"</b>	<b>2"</b>
Control Valve	H-10914 1-1/2"	H-10918 1-1/2"	H-10914 2"	H-10917 2"	H-10918 2"
Bushing	-	-	-	-	-
<b>Installation</b>					
Center Locating Punch	H-17615	H-17615	-	-	-
Test Cap	79161	79161	36811	36811	36811
Completion Plug Wrench	96536	96536	581264	581264	581264
<b>Drilling</b>					
<b>MAOP*</b>	125 psig	250 psig	125 psig	250 psig	250 psig
Power Operator	H-604	H-604	H-604	H-604	H-604
Machine Adapter	36196	36196	36188	36188	36188
Drill	33529 1"	33529 1"	-	-	-
Drill Holder	33555	33555	-	-	-
Shell Cutter	-	-	78910 1-1/2"	78910 1-1/2"	78910 1-1/2"
Shell Cutter Holder	-	-	33316	33316	33316
Cutter Holder Extension	-	-	-	-	63392
Cutting Grease	88366	88366	88366	88366	88366
Honing Stone	682560	682560	682560	682560	682560
<b>Stopping</b>					
<b>MAOP†</b>	125 psig	250 psig	125 psig	250 psig	250 psig
Machine Adapter	36196	36196	36188	36188	36188
Steel Shut Off Tool	33600	33600	36189	36189	36189
Rubber Shut Off Tool	88758	88758	88773	88773	88773
Replacement Rubber	37459	37459	37555	37555	37555
Holder for Rubber Shut Off Tool	61969	61969	33316	33316	33316
Boring Bar Adapter	36324	36324	-	-	-
Rubber Stopper Lubricant	580657	580657	580657	580657	580657
<b>Inserting</b>					
<b>MAOP*</b>	125 psig	250 psig	125 psig	250 psig	250 psig
Machine Adapter	36196	36196	36188	36188	36188
EZ Release Inserting Tool	83257	83257	83258	83258	83258
Boring Bar Adapter	36324	36324	36324	36324	36324
<b>Extracting</b>					
<b>MAOP*</b>	125 psig	250 psig	125 psig	250 psig	250 psig
Machine Adapter	36196	36196	36188	36188	36188
Extracting Tool	88286	88286	88384	88384	88384

\*Maximum Allowable Operating Pressure

†In stopping section of chart, Maximum Allowable Operating Pressure (MAOP) applies to use of rubber shut off tool only. For steel shut off tool, variables in hole drilled in pipe may or may not allow similar MAOP.

Rev. 6-10 Shaded area indicates changes

- Catalog number – **H-17501**
- Sizes\* – 3/4" x 3/4", 1" x 1", 1-1/4" x 1-1/4", 2" x 2"
- Forged Steel Body ASTM A105
- Forged steel Completion Cap ASTM A105
- Brass Completion Plug - 3/4" x 3/4", 1" x 1", 1-1/4" x 1-1/4"
- Cast Iron Completion Plug - 2" x 2"
- Weld inlet
- Outlet prepared for butt weld same size as outlet and socket weld one size smaller than outlet
- 1440\*\* psig (9330 kPa)

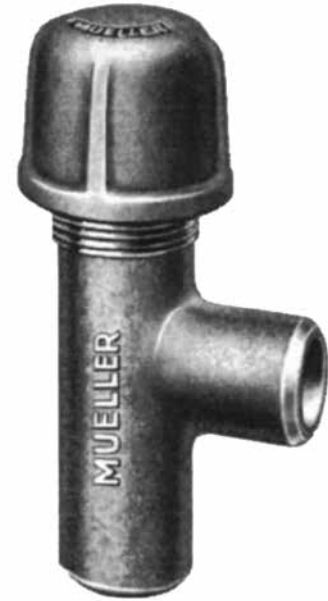

**H-17501**

### How to select equipment

- 1) Find chart on following pages containing desired combination of fitting and installation machine (shown in bold type at top of each page and chart). Note: for a given fitting there may be more than one machine and chart.
- 2) Under inlet size of fitting to be installed, select catalog number for type of control valve to be used. Options may include one or more of the following: H-10914 Bronze Gate Valve, H-17025 Control Chamber, H-10917 Slide Gate Valve, H-10918 Steel Ball Valve.
- 3) Under selected control valve, column lists equipment necessary for each operation on chosen size of fitting. Note: **MAOP** (Maximum Allowed Operating Pressure) provided for **each** operation must not be exceeded. MAOP may be different for each operation.

### Dimensions

Dimensions	Size* of Service Tee			
	3/4" x 3/4"	1" x 1"	1-1/4" x 1-1/4"	2" x 2"
A	4"	4-1/8"	4-5/8"	5-1/2"
B	1-3/4"	1-7/8"	2"	2-1/8"
C	1"	1-1/4"	1-1/2"	2"
D	1/2"	3/4"	1"	1-1/2"

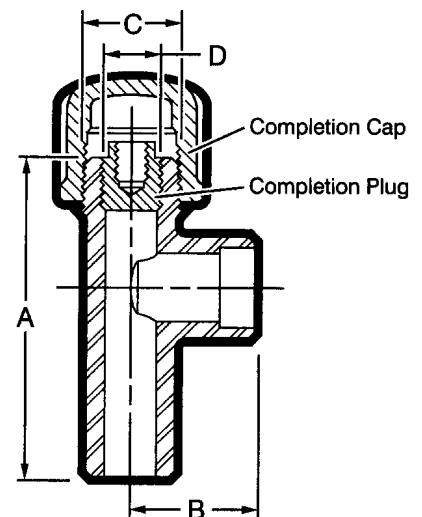

### Replacement Parts

Replacement Parts	Size* of Service Tee			
	3/4" x 3/4"	1" x 1"	1-1/4" x 1-1/4"	2" x 2"
Completion Cap	52412	52413	52416	52430
Completion Plug	78898	34060	34122	36356

\*First size is size of inlet, second is size of outlet.

\*\*This is the maximum pressure of the fitting installed in the line at 100F for Class Locations 1, 2, 3 and 4 as defined in D.O.T./CFR TITLE 49 PART 192. It may be necessary to reduce the line pressure during the drilling, stopping or plugging operations to the maximum working pressure of the machine or its attachments. Refer to charts on following pages.



**E-5™/EH-5™ Machine**

<b>H-17501</b>	<b>3/4"</b>	<b>3/4"</b>	<b>3/4"</b>	<b>1"</b>	<b>1"</b>	<b>1"</b>
Control Valve	H-10914 1-1/4"	H-17025	H-10918 1-1/4"	H-10914 1-1/4"	H-17025	H-10918 1-1/4"
Bushing	-	78829 1"	-	-	78830 1-1/4"	-
<b>Installation</b>						
Center Locating Punch	H-17615	H-17615	H-17615	H-17615	H-17615	H-17615
Test Cap - Steel	537398	537398	537398	537399	537399	537399
Completion Plug Wrench	96536	96536	96536	96536	96536	96536
<b>Drilling</b>						
<b>MAOP*</b>	125 psig	125 psig	500 psig =E-5 1200 psig =EH-5	125	125	500 psig=E-5 1200 psig =EH-5
Power Operator	H-604	H-604	H-604	H-604	H-604	H-604
Machine Adapter	36733	-	36733	36733	-	36733
Reducing Bushing	36969 1-1/4" x 1"	-	36969 1-1/4" x 1"	-	-	-
Drill	61982 5/8"	61982 5/8"	61982 5/8"	-	-	-
Drill Holder	61981	61981	61981	-	-	-
Combined Drill and Holder	-	-	-	79185 3/4"	79185 3/4"	79185 3/4"
Cutting Grease	88366	88366	88366	88366	88366	88366
Honing Stone	682560	682560	682560	682560	682560	682560
<b>Stopping</b>						
<b>MAOP†</b>	125 psig	125 psig	500 psig	125 psig	125 psig	500 psig
Machine Adapter	36733	-	36733	36733	-	36733
Reducing Bushing	36969 1-1/4" x 1"	-	36969 1-1/4" x 1"	-	-	-
Steel Shut Off Tool	45628	45628	45628	36197	36197	36197
Rubber Shut Off Tool	88757	88757	88757	88125	88125	88125
Replacement Rubber	37454	37454	37454	37629	37629	37629
Holder for Rubber Shut Off Tool	61981	63396	61981	61789	61789	61789
Rubber Stopper Lubricant	580657	580657	580657	580657	580657	580657
<b>Inserting</b>						
<b>MAOP*</b>	125 psig	125 psig	500 psig=E-5 1200 psig=EH-5	125 psig	125 psig	500 psig=E-5 1200 psig=EH-5
Machine Adapter	36733	-	36733	36733	-	36733
Reducing Bushing	36969 1-1/4" x 1"	-	36969 1-1/4" x 1"	-	-	-
EZ Release Inserting Tool	83261	83261	83261	83261	83261	83261
<b>Extracting</b>						
<b>MAOP*</b>	125 psig	125 psig	500 psig =E-5 1200 psig =EH-5	125 psig	125 psig	500 psig =E-5 1200 psig =EH-5
Machine Adapter	36733	-	36733	36733	-	36733
Reducing Bushing	36969 1-1/4" x 1"	-	36969 1-1/4" x 1"	-	-	-
Extracting Tool	80088	80088	80088	80088	80088	80088

\*Maximum Allowable Operating Pressure

†In stopping section of chart, Maximum Allowable Operating Pressure (MAOP) applies to use of rubber shut off tool only. For steel shut off tool, variables in hole drilled in pipe may or may not allow similar MAOP.

Rev. 9-15 Shaded area indicates changes

## E-5™/EH-5™ Machine

H-17501	1-1/4"	1-1/4"	1-1/4"	2"	2"	2"
Control Valve	H-10914 1-1/2"	H-17025	H-10918 1-1/2"	H-10914 2"	H-10917 2"	H-10918 2"
Bushing	-	78831 1-1/2"	-	-	-	-
<b>Installation</b>						
Center Locating Punch	H-17615	H-17615	H-17615	-	-	-
Test Cap - Steel	537400	537400	537400	537401	537401	537401
Completion Plug Wrench	96536	96536	96536	581264	581264	581264
<b>Drilling</b>						
<b>MAOP*</b>	125 psig	125 psig	500 psig =E-5 1200 psig =EH-5	125 psig	275 psig	500 psig =E-5 1200 psig =EH-5
Power Operator	H-604	H-604	H-604	H-604	H-604	H-604
Machine Adapter	33575	-	33575	78907	78907	528329
Combined Drill and Holder	79186 1"	79186 1"	79186 1"	-	-	-
Shell Cutter	-	-	-	78910 1-1/2"	78910 1-1/2"	78910 1-1/2"
Shell Cutter Holder	-	-	-	78906	78906	501545
Cutter Holder Extension	-	-	-	-	-	63392
Cutting Grease	88366	88366	88366	88366	88366	88366
Honing Stone	682560	682560	682560	682560	682560	682560
<b>Stopping</b>						
<b>MAOP†</b>	125 psig	125 psig	500 psig	125 psig	275 psig	500 psig
Machine Adapter for Steel Shut Off Tool	33575	-	33575	78907	78907	528336
Steel Shut Off Tool	33570	33570	33570	78902	78902	78902
Machine Adapter for Rubber Shut Off Tool	33575	-	33575	78907	78907	528329
Rubber Shut Off Tool	88758	88758	88758	88773	88773	88773
Replacement Rubber	37459	37459	37459	37555	37555	37555
Holder for Rubber Shut Off Tool	61969	61969	61969	78906	78906	501545
Holder Extension for Rubber Shut Off Tool	-	-	-	-	-	63392
Rubber Stopper Lubricant	580657	580657	580657	580657	580657	580657
<b>Inserting</b>						
<b>MAOP*</b>	125 psig	125 psig	500 psig =E-5 1200 psig =EH-5	125 psig	275 psig	500 psig =E-5 1200 psig =EH-5
Machine Adapter	33575	-	33575	78907	78907	528329
EZ Release Inserting Tool	83261	83261	83261	83258	83258	83258
<b>Extracting</b>						
<b>MAOP*</b>	125 psig	125 psig	500 psig =E-5 1200 psig =EH-5	125 psig	275 psig	500 psig =E-5 1200 psig =EH-5
Machine Adapter	33575	-	33575	78907	78907	528329
Extracting Tool	80088	80088	80088	80087	80087	83262

\*Maximum Allowable Operating Pressure

†In stopping section of chart, Maximum Allowable Operating Pressure (MAOP) applies to use of rubber shut off tool only. For steel shut off tool, variables in hole drilled in pipe may or may not allow similar MAOP.

**D-5™/DH-5™ Machine**

<b>H-17501</b>	<b>3/4"</b>	<b>3/4"</b>	<b>1"</b>	<b>1"</b>
Control Valve	H-10914 1-1/4"	H-10918 1-1/4"	H-10914 1-1/4"	H-10918 1-1/4"
<b>Installation</b>				
Center Locating Punch	H-17615	H-17615	H-17615	H-17615
Test Cap - Steel	537398	537398	537399	537399
Completion Plug Wrench	96536	96536	96536	96536
<b>Drilling</b>				
<b>MAOP*</b>	125 psig	500 psig =D-5 1200 psig =DH-5	125 psig	500 psig =D-5 1200 psig =DH-5
Power Operator	H-604	H-604	H-604	H-604
Machine Adapter	36195	36195	36195	36195
Reducing Bushing	36969 1-1/4" x 1"	36969 1-1/4" x 1"	-	-
Drill	61982 5/8"	61982 5/8"	-	-
Drill Holder	36998	36998	-	-
Combined Drill and Holder	-	-	79185 3/4"	79185 3/4"
Boring Bar Adapter	-	-	36324	36324
Cutting Grease	88366	88366	88366	88366
Honing Stone	682560	682560	682560	682560
<b>Stopping</b>				
<b>MAOP†</b>	125 psig	500 psig	125 psig	500 psig
Machine Adapter	36195	36195	36195	36195
Reducing Bushing	36969 1-1/4" x 1"	36969 1-1/4" x 1"	-	-
Steel Shut Off Tool	45628	45628	36197	36197
Boring Bar Adapter**	36324	36324	36324	36324
Rubber Shut Off Tool	88757	88757	88125	88125
Replacement Rubber	37454	37454	37629	37629
Rubber Shut Off Holder	36998	36998	36915	36915
Rubber Stopper Lubricant	580657	580657	580657	580657
<b>Inserting</b>				
<b>MAOP*</b>	125 psig	500 psig =D-5 1200 psig =DH-5	125 psig	500 psig=D-5 1200 psig =DH-5
Machine Adapter	36195	36195	36195	36195
Reducing Bushing	36969 1-1/4" x 1"	36969 1-1/4" x 1"	-	-
EZ Release Inserting Tool	83261	83261	83261	83261
Boring Bar Adapter	36324	36324	36324	36324
<b>Extracting</b>				
<b>MAOP*</b>	125 psig	500 psig =D-5 1200 psig =DH-5	125 psig	500 psig =D-5 1200 psig =DH-5
Machine Adapter	36195	36195	36195	36195
Reducing Bushing	36969 1-1/4" x 1"	36969 1-1/4" x 1"	-	-
Extracting Tool	88286	88286	88286	88286

\*Maximum Allowable Operating Pressure

\*\*Only used with steel shut-off tool.

†In stopping section of chart, Maximum Allowable Operating Pressure (MAOP) applies to use of rubber shut off tool only. For steel shut off tool, variables in hole drilled in pipe may or may not allow similar MAOP.

**D-5™/DH-5™ Machine**

H-17501	1-1/4"	1-1/4"	2"	2"	2"
Control Valve	H-10914 1-1/2"	H-10918 1-1/2"	H-10914 2"	H-10917 2"	H-10918 2"
Bushing	-	-	-	-	-
<b>Installation</b>					
Center Locating Punch	H-17615	H-17615	-	-	-
Test Cap - Steel	537400	537400	537401	537401	537401
Completion Plug Wrench	96536	96536	581264	581264	
<b>Drilling</b>					
<b>MAOP*</b>	125 psig	500 psig =D-5 1200 psig =DH-5	125 psig	275 psig	500 psig =D-5 1200 psig =DH-5
Power Operator	H-604	H-604	H-604	H-604	H-604
Machine Adapter	36196	36196	36188	36188	36188
Drill	33529 1"	33529 1"	-	-	-
Drill Holder	33555	33555	-	-	-
Shell Cutter	-	-	78910 1-1/2"	78910 1-1/2"	78910 1-1/2"
Shell Cutter Holder	-	-	33316	33316	33316
Cutter Holder Extension	-	-	-	-	63392
Cutting Grease	88366	88366	88366	88366	88366
Honing Stone	682560	682560	682560	682560	682560
<b>Stopping</b>					
<b>MAOP†</b>	125 psig	500 psig	125 psig	275 psig	500 psig
Machine Adapter	36196	36196	36188	36188	36188
Steel Shut Off Tool	33600	33600	36189	36189	36189
Rubber Shut Off Tool	88758	88758	88773	88773	88773
Replacement Rubber	37459	37459	37555	37555	37555
Holder for Rubber Shut Off Tool	61969	61969	33316	33316	33316
Boring Bar Adapter	36324	36324	-	-	-
Rubber Stopper Lubricant	580657	580657	580657	580657	580657
<b>Inserting</b>					
<b>MAOP*</b>	125 psig	500 psig =D-5 1200 psig =DH-5	125 psig	275 psig	500 psig =D-5 1200 psig =DH-5
Machine Adapter	36196	36196	36188	36188	36188
EZ Release Inserting Tool	83257	83257	83258	83258	83258
Boring Bar Adapter	36324	36324	36324	36324	36324
<b>Extracting</b>					
<b>MAOP*</b>	125 psig	500 psig =D-5 1200 psig =DH-5	125 psig	275 psig	500 psig =D-5 1200 psig =DH-5
Machine Adapter	36196	36196	36188	36188	36188
Extracting Tool	88286	88286	88384	88384	88384

\*Maximum Allowable Operating Pressure

†In stopping section of chart, Maximum Allowable Operating Pressure (MAOP) applies to use of rubber shut off tool only. For steel shut off tool, variables in hole drilled in pipe may or may not allow similar MAOP.

# MUELLER® NO-BLO® SERVICE TEE WELD x WELD - 250 PSIG

**Mueller Co.**

Reliable Connections®

# 3.13

Shaded area indicates change Rev. 12-06

- Catalog number – **H-17502**
- Size\* – 2" x 2"
- Forged Steel Body ASTM A105
- Cast Iron Completion Cap ASTM A126 CL.B
- Cast Iron Completion Plug ASTM A126 CL. B
- O-ring Sealed Completion Plug
- Weld inlet contoured to fit 2" steel pipe
- Outlet prepared for butt weld same size as outlet and socket weld one size smaller than outlet
- 250\*\* psig (1724 kPa)



**H-17502**

## How to select equipment

- 1) Find chart on following pages containing desired combination of fitting and installation machine (shown in bold type at top of each page and chart). Note: for a given fitting there may be more than one machine and chart.
- 2) Under inlet size of fitting to be installed, select catalog number for type of control valve to be used. Options may include one or more of the following: H-10914 Bronze Gate Valve, H-17025 Control Chamber, H-10917 Slide Gate Valve, H-10918 Steel Ball Valve.
- 3) Under selected control valve, column lists equipment necessary for each operation on chosen size of fitting. Note: **MAOP** (Maximum Allowed Operating Pressure) provided for **each** operation must not be exceeded. MAOP may be different for each operation.

## Dimensions

Dimensions	Size* of Service Tee
	2" x 2"
A	5-9/16"
B	2-1/8"
C	2"
D	1-7/8"

## Replacement Parts

Replacement Parts	Size* of Service Tee
	2" x 2"
Completion Cap	36310
Completion Plug	502905
Completion Plug O-ring	79268

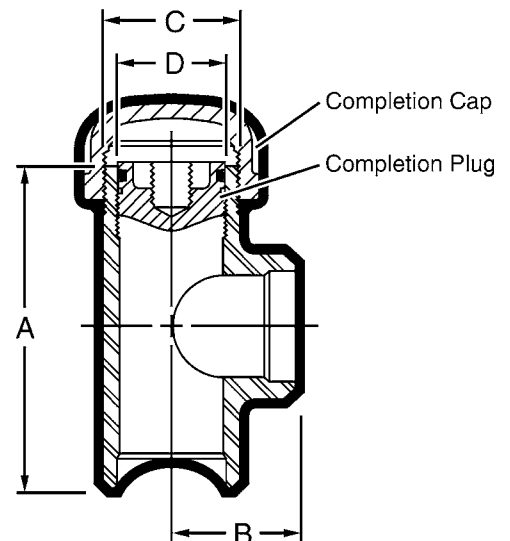

\*First size is size of inlet, second is size of outlet.

\*\*This is the maximum pressure of the fitting installed in the line at 100F for Class Locations 1, 2, 3 and 4 as defined in D.O.T./CFR TITLE 49 PART 192. It may be necessary to reduce the line pressure during the drilling, stopping or plugging operations to the maximum working pressure of the machine or its attachments. Refer to charts on following pages.

Rev. 9-15 Shaded area indicates changes

**E-5™/EH-5™ Machine**

H-17502	2"	2"	2"
Control Valve	H-10914 2"	H-10917 2"	H-10918 2"
Bushing	-	-	-
<b>Installation</b>			
Test Cap	36811	36811	36811
Completion Plug Wrench	581264	581264	581264
<b>Drilling</b>			
<b>MAOP*</b>	125 psig	250 psig	250 psig
Power Operator	H-604	H-604	H-604
Machine Adapter	78907	78907	528329
Shell Cutter Complete	78910 1-1/2"	78910 1-1/2"	78910 1-1/2"
Shell Cutter Holder	78906	78906	501545
Cutter Holder Extension	63362	63362	63362
Cutting Grease	88366	88366	88366
Honing Stone	682560	682560	682560
<b>Stopping</b>			
<b>MAOP†</b>	125 psig	250 psig	250 psig
Machine Adapter for Steel Shut Off Tool	78907	78907	528336
Steel Shut Off Tool	78902	78902	78902
Machine Adapter for Rubber Shut Off Tool	78907	78907	528329
Rubber Shut Off Tool	88773	88773	88773
Replacement Rubber	37555	37555	37555
Holder for Rubber Shut Off Tool	78906	78906	501545
Holder Extension for Rubber Shut Off Tool	-	-	63392
Rubber Stopper Lubricant	580657	580657	580657
<b>Inserting</b>			
<b>MAOP*</b>	125 psig	250 psig	250 psig
Machine Adapter	78907	78907	528329
EZ Release Inserting Tool	83258	83258	83258
<b>Extracting</b>			
<b>MAOP*</b>	125 psig	250 psig	250 psig
Machine Adapter	78907	78907	528329
Extracting Tool	83262	83262	83262

\*Maximum Allowable Operating Pressure

†In stopping section of chart, Maximum Allowable Operating Pressure (MAOP) applies to use of rubber shut off tool only. For steel shut off tool, variables in hole drilled in pipe may or may not allow similar MAOP.

**D-5/DH-5 Machine**

<b>H-17502</b>	<b>2"</b>	<b>2"</b>	<b>2"</b>
Control Valve	H-10914 2"	H-10917 2"	H-10918 2"
Bushing	-	-	-
<b>Installation</b>			
Test Cap	36811	36811	36811
Completion Plug Wrench	581264	581264	581264
<b>Drilling</b>			
<b>MAOP*</b>	125 psig	250 psig	250 psig
Power Operator	H-604	H-604	H-604
Machine Adapter	36188	36188	36188
Shell Cutter Complete	78910 1-1/2"	78910 1-1/2"	78910 1-1/2"
Cutter Holder	33316	33316	33316
Cutter Holder Extension	-	-	63392
Cutting Grease	88366	88366	88366
Honing Stone	682560	682560	682560
<b>Stopping</b>			
<b>MAOP†</b>	125 psig	250 psig	250 psig
Machine Adapter	36188	36188	36188
Steel Shutoff Tool (Stop Off Tee Outlet Only)	36189	36189	36189
Rubber Shutoff Tool (Stop Off Tee Outlet Only)	88773	88773	88773
Replacement Rubber	37555	37555	37555
Rubber Shutoff Tool Holder	33316	33316	33316
Rubber Stopper Lubricant	580657	580657	580657
<b>Inserting</b>			
<b>MAOP*</b>	125 psig	250 psig	250 psig
Machine Adapter	36188	36188	36188
EZ Release Inserting Tool	83258	83258	83258
Boring Bar Adapter	40438	40438	40438
<b>Extracting</b>			
<b>MAOP*</b>	125 psig	250 psig	250 psig
Machine Adapter	36188	36188	36188
Extracting Tool	88384	88384	88384

\*Maximum Allowable Operating Pressure

†In stopping section of chart, Maximum Allowable Operating Pressure (MAOP) applies to use of rubber shut off tool only. For steel shut off tool, variables in hole drilled in pipe may or may not allow similar MAOP.

Rev. 12-06 Shaded area indicates changes

- Catalog number – **H-17503**
- Sizes\* – 1-1/4" x 1-1/4", 3" x 3", 4" x 4"
- Forged Steel Body ASTM A105/A234WPB
- Cast Iron Completion Cap ASTM A126 CL.B
- Cast Iron Completion Plug ASTM A126 CL.B
- O-ring Sealed Completion Plug
- Weld inlet
- Outlet prepared for butt weld same size as outlet and socket weld one size smaller than outlet
- 250\*\* psig (1724 kPa)



**H-17503**

### How to select equipment

- 1) Find chart on following pages containing desired combination of fitting and installation machine (shown in bold type at top of each page and chart). Note: for a given fitting there may be more than one machine and chart.
- 2) Under inlet size of fitting to be installed, select catalog number for type of control valve to be used. Options may include one or more of the following: H-10914 Bronze Gate Valve, H-17025 Control Chamber, H-10917 Slide Gate Valve, H-10918 Steel Ball Valve.
- 3) Under selected control valve, column lists equipment necessary for each operation on chosen size of fitting. Note: **MAOP** (Maximum Allowed Operating Pressure) provided for **each** operation must not be exceeded. MAOP may be different for each operation.

### Dimensions

Dimensions	Size* of Service Tee		
	1-1/4" x 1-1/4"	3" x 3"	4" x 4"
A	4-5/8"	9"	8-3/8"
B	2"	3-3/8"	4-1/8"
C	1-1/2"	3"	4"
D	1-3/8"	2-7/8"	3-7/8"

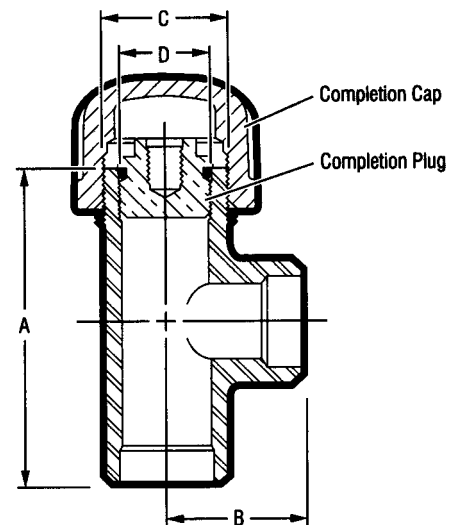

### Replacement Parts

Replacement Parts	Size* of Service Tee		
	1-1/4" x 1-1/4"	3" x 3"	4" x 4"
Completion Cap	38138	36312	502944
Completion Plug	503445	502955	580911
Completion Plug O-ring	40709	503164	60192

\*First size is size of inlet, second is size of outlet.

\*\*This is the maximum pressure of the fitting installed in the line at 100F for Class Locations 1, 2, 3 and 4 as defined in D.O.T./CFR TITLE 49 PART 192. It may be necessary to reduce the line pressure during the drilling, stopping or plugging operations to the maximum working pressure of the machine or its attachments. Refer to charts on following pages.



**E-5/EH-5 Machine**

<b>H-17503</b>	<b>1-1/4"</b>	<b>1-1/4"</b>
Control Valve	H-10914 1-1/2"	H-10918 1-1/2"
<b>Installation</b>		
Test Cap	79161	79161
Completion Plug Wrench	96536	96536
<b>Drilling</b>		
<b>MAOP*</b>	125 psig	250 psig
Power Operator	H-604	H-604
Machine Adapter	33575	33575
Combined Drill and Holder	79186 1"	79186 1"
Cutting Grease	88366	88366
Honing Stone	682560	682560
<b>Stopping</b>		
<b>MAOP†</b>	125 psig	250 psig
Machine Adapter	503435	503435
Rubber Shutoff Tool	88758	88758
Replacement Rubber	37459	37459
Rubber Stopper Holder	61969	61969
Rubber Stopper Lubricant	580657	580657
<b>Inserting</b>		
<b>MAOP*</b>	125 psig	250 psig
Machine Adapter	33575	33575
EZ Release Inserting Tool	83257	83257
<b>Extracting</b>		
<b>MAOP*</b>	125 psig	250 psig
Machine Adapter	33575	33575
Extracting Tool	83212	83212

\*Maximum Allowable Operating Pressure

†In stopping section of chart, Maximum Allowable Operating Pressure (MAOP) applies to use of rubber shut off tool only. For steel shut off tool, variables in hole drilled in pipe may or may not allow similar MAOP.

Rev. 9-15 Shaded area indicates changes

**D-5™/DH-5™ Machine**

<b>H-17503</b>	<b>1-1/4"</b>	<b>1-1/4"</b>	<b>3"</b>	<b>4"</b>
Control Valve	H-10914 1-1/2"	H-10918 1-1/2"	H-10917 3"	H-10917 4"
Bushing	-	-	-	-
<b>Installation</b>				
Center Locating Punch	H-17615	H-17615	-	-
Test Cap	79161	79161	36813	502929
Completion Plug Wrench	96536	96536	581264	36404
<b>Drilling</b>				
<b>MAOP*</b>	125 psig	250 psig	250 psig	250 psig
Power Operator	H-604	H-604	H-604	H-604
Machine Adapter	36196	36196	580918	580906
Shell Cutter	-	-	89351 2-3/4"	89352 3-3/4"
Cutter Holder	-	-	33316	33316
Boring Bar Adapter	-	-	64297	64297
Drill	33529 1"	33529 1"	-	-
Holder	33555	33555	-	-
Cutting Grease	88366	88366	88366	88366
Honing Stone	682560	682560	682560	682560
<b>Stopping**</b>				
<b>MAOP†</b>	125 psig	250 psig	X	X
Machine Adapter	36196	36196	X	X
Steel Shutoff Tool	33600	33600	X	X
Rubber Shutoff Tool	88758	88758	X	X
Replacement Rubber	37459	37459	X	X
Rubber Shutoff Tool Holder	61969	61969	X	X
Boring Bar Adapter	36324	36324	X	X
Rubber Stopper Lubricant	580657	580657	X	X
<b>Inserting</b>				
<b>MAOP*</b>	125 psig	250 psig	250 psig	250 psig
Machine Adapter	36196	36196	580918	580906
EZ Release Inserting Tool	83261	83261	580921	580908
Boring Bar Adapter	40438	40438	-	502937
<b>Extracting</b>				
<b>MAOP*</b>	125 psig	250 psig	250 psig	250 psig
Machine Adapter	36196	36196	580918	580906
Extracting Tool	80088	80088	580919	580913
Boring Bar Adapter	36198	36198	-	-

\*Maximum Allowable Operating Pressure

\*\*Stopping not an option using 3" and 4" Service Tees.

†In stopping section of chart, Maximum Allowable Operating Pressure (MAOP) applies to use of rubber shut off tool only. For steel shut off tool, variables in hole drilled in pipe may or may not allow similar MAOP.

- Catalog number – **H-17504**
- Sizes\* – 3/4" x 1/2" MD CTS,  
3/4" x 3/4" MD IPS, 3/4" x 3/4" HD IPS,  
1" x 3/4" MD IPS, 1" x 1" MD CTS, 1" x 1" MD IPS,  
1" x 1" HD IPS, 1-1/4" x 1-1/4" MD IPS,  
1-1/4" x 1-1/4" HD IPS, 2" x 2" MD IPS
- Conforms to ASTM D638 and DOT192.283.
- Forged Steel Body ASTM A105
- Cast Iron Completion Cap ASTM A126 CL.B
- Fusion epoxy coating resists corrosion
- 100 psig\*\* (690 kPa)

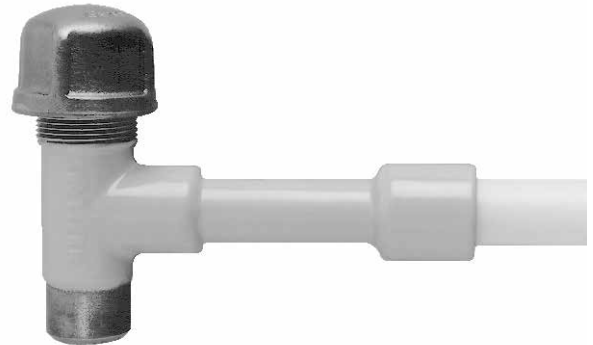

**H-17504**

**How to select equipment**

- 1) Find chart on following pages containing desired combination of fitting and installation machine (shown in bold type at top of each page and chart). Note: for a given fitting there may be more than one machine and chart.
- 2) Under inlet size of fitting to be installed, select catalog number for type of control valve to be used. Options may include one or more of the following: H-10914 Bronze Gate Valve, H-17025 Control Chamber, H-10917 Slide Gate Valve, H-10918 Steel Ball Valve.
- 3) Under selected control valve, column lists equipment necessary for each operation on chosen size of fitting. Note: **MAOP** (Maximum Allowed Operating Pressure) provided for **each** operation must not be exceeded. MAOP may be different for each operation.

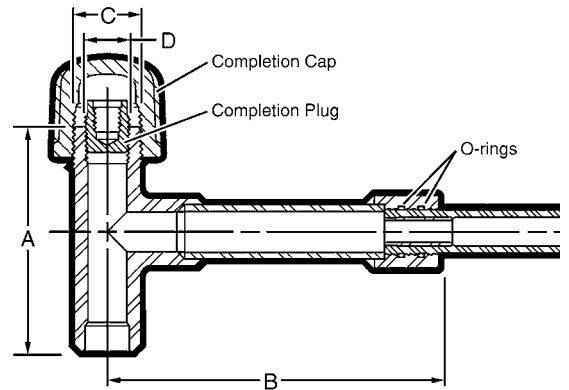

**Dimensions**

Dimensions	Size* of Service Tee						
	3/4" x 1/2"	3/4" x 3/4"	1" x 3/4"	1" x 1"	1-1/4" x 1"	1-1/4" x 1-1/4"	2" x 2"
A	4"	4"	4-1/8"	4-1/8"	4-5/8"	4-5/8"	5-1/2"
B	6-5/8"	6-3/4"	6-11/16"	6-3/4"	7-11/32"	6-11/16"	6-11/16"
C	1"	1"	1-1/4"	1-1/4"	1-1/2"	1-1/2"	2"
D	1/2"	1/2"	3/4"	3/4"	1"	1"	1-1/2"

**Replacement Parts**

Replacement Parts	Size* of Service Tee						
	3/4" x 1/2"	3/4" x 3/4"	1" x 3/4"	1" x 1"	1-1/4" x 1"	1-1/4" x 1-1/4"	2" x 2"
Completion Cap	34061	34061	37483	37483	38138	38138	36310
Completion Plug	78898	78898	34060	34060	34122	34122	36356

\*First size is size of inlet, second is size of outlet.

\*\*This is the maximum pressure of the fitting installed in the line at 100F for Class Locations 1, 2, 3 and 4 as defined in D.O.T./CFR TITLE 49 PART 192. It may be necessary to reduce the line pressure during the drilling, stopping or plugging operations to the maximum working pressure of the machine or its attachments. Refer to charts on following pages.

Rev. 12-06 Shaded area indicates changes

**E-5™/EH-5™ Machine**

H-17504	3/4"	3/4"	3/4"	1"	1"	1"
Control Valve	H-10914 1-1/4"	H-17025	H-10918 1-1/4"	H-10914 1-1/4"	H-17025	H-10918 1-1/4"
Bushing	-	78829 1"	-	-	78830 1-1/4"	-
<b>Installation</b>						
Center Locating Punch	H-17615	H-17615	H-17615	H-17615	H-17615	H-17615
Test Cap	79159	79159	79159	79160	79160	79160
Completion Plug Wrench	96536	96536	96536	96536	96536	96536
<b>Drilling</b>						
<b>MAOP*</b>	100 psig	100 psig	100 psig	100 psig	100 psig	100 psig
Power Operator	H-604	H-604	H-604	H-604	H-604	H-604
Machine Adapter	36733	-	36733	36733	-	36733
Reducing Bushing	36969 1-1/4" x 1"	-	36969 1-1/4" x 1"	-	-	-
Drill	61982 5/8"	61982 5/8"	61982 5/8"	-	-	-
Drill Holder	61981	61981	61981	-	-	-
Combined Drill and Holder	-	-	-	79185 3/4"	79185 3/4"	79185 3/4"
Cutting Grease	88366	88366	88366	88366	88366	88366
Honing Stone	682560	682560	682560	682560	682560	682560
<b>Stopping</b>						
<b>MAOP†</b>	100 psig	100 psig	100 psig	100 psig	100 psig	100 psig
Machine Adapter	36733	-	36733	36733	-	36733
Reducing Bushing	36969 1-1/4" x 1"	-	36969 1-1/4" x 1"	-	-	-
Steel Shut Off Tool	45628	45628	45628	36197	36197	36197
Rubber Shut Off Tool	88757	88757	88757	88125	88125	88125
Replacement Rubber	37454	37454	37454	37629	37629	37629
Holder for Rubber Shut Off Tool	61981	63396	61981	61789	61789	61789
Rubber Stopper Lubricant	580657	580657	580657	580657	580657	580657
<b>Inserting</b>						
<b>MAOP*</b>	100 psig	100 psig	100 psig	100 psig	100 psig	100 psig
Machine Adapter	36733	-	36733	36733	-	36733
Reducing Bushing	36969 1-1/4" x 1"	-	36969 1-1/4" x 1"	-	-	-
EZ Release Inserting Tool	83261	83261	83261	83261	83261	83261
<b>Extracting</b>						
<b>MAOP*</b>	100 psig	100 psig	100 psig	100 psig	100 psig	100 psig
Machine Adapter	36733	-	36733	36733	-	36733
Reducing Bushing	36969 1-1/4" x 1"	-	36969 1-1/4" x 1"	-	-	-
Extracting Tool	80088	80088	80088	80088	80088	80088
Extracting Tool Adapter	-	-	-	-	-	-

\*Maximum Allowable Operating Pressure

†In stopping section of chart, Maximum Allowable Operating Pressure (MAOP) applies to use of rubber shut off tool only. For steel shut off tool, variables in hole drilled in pipe may or may not allow similar MAOP.

**E-5™/EH-5™ Machine**

<b>H-17504</b>	<b>1-1/4"</b>	<b>1-1/4"</b>	<b>1-1/4"</b>	<b>2"</b>	<b>2"</b>	<b>2"</b>
Control Valve	H-10914 1-1/2"	H-17025	H-10918 1-1/2"	H-10914 2"	H-10917 2"	H-10918 2"
Bushing	-	78831 1-1/2"	-	-	-	-
<b>Installation</b>						
Center Locating Punch	H-17615	H-17615	H-17615	-	-	-
Test Cap	79161	79161	79161	36811	36811	36811
Completion Plug Wrench	96536	96536	96536	581264	581264	581264
<b>Drilling</b>						
<b>MAOP*</b>	100 psig	100 psig	100 psig	100 psig	100 psig	100 psig
Power Operator	H-604	H-604	H-604	H-604	H-604	H-604
Machine Adapter	33575	-	33575	78907	78907	528329
Combined Drill and Holder	79186 1"	79186 1"	79186 1"	-	-	-
Shell Cutter	-	-	-	78910 1-1/2"	78910 1-1/2"	78910 1-1/2"
Shell Cutter Holder	-	-	-	78906	78906	501545
Cutter Holder Extension	-	-	-	-	-	63392
Cutting Grease	88366	88366	88366	88366	88366	88366
Honing Stone	682560	682560	682560	682560	682560	682560
<b>Stopping</b>						
<b>MAOP†</b>	100 psig	100 psig	100 psig	100 psig	100 psig	100 psig
Machine Adapter for Steel Shut Off Tool	33575	-	33575	78907	78907	528336
Steel Shut Off Tool	33570	33570	33570	78902	78902	78902
Machine Adapter for Rubber Shut Off Tool	33575	-	33575	78907	78907	528329
Rubber Shut Off Tool	88758	88758	88758	88773	88773	88773
Replacement Rubber	37459	37459	37459	37555	37555	37555
Holder for Rubber Shut Off Tool	61969	61969	61969	78906	78906	501545
Holder Extension for Rubber Shut Off Tool	-	-	-	-	-	63392
Rubber Stopper Lubricant	580657	580657	580657	580657	580657	580657
<b>Inserting</b>						
<b>MAOP*</b>	100 psig	100 psig	100 psig	100 psig	100 psig	100 psig
Machine Adapter	33575	-	33575	78907	78907	528329
EZ Release Inserting Tool	83261	83261	83261	83258	83258	83258
<b>Extracting</b>						
<b>MAOP*</b>	100 psig	100 psig	100 psig	100 psig	100 psig	100 psig
Machine Adapter	33575	-	33575	78907	78907	528329
Extracting Tool	80088	80088	80088	80087	80087	83262

\*Maximum Allowable Operating Pressure

†In stopping section of chart, Maximum Allowable Operating Pressure (MAOP) applies to use of rubber shut off tool only. For steel shut off tool, variables in hole drilled in pipe may or may not allow similar MAOP.

**D-5™/DH-5™ Machine**

H-17504	3/4"	3/4"	1"	1"
Control Valve	H-10914 1-1/4"	H-10918 1-1/4"	H-10914 1-1/4"	H-10918 1-1/4"
<b>Installation</b>				
Center Locating Punch	H-17615	H-17615	H-17615	H-17615
Test Cap	79159	79159	79160	79160
Completion Plug Wrench	96536	96536	96536	96536
<b>Drilling</b>				
<b>MAOP*</b>	100 psig	100 psig	100 psig	100 psig
Power Operator	H-604	H-604	H-604	H-604
Machine Adapter	36195	36195	36195	36195
Reducing Bushing	36969 1-1/4" x 1"	36969 1-1/4" x 1"	-	-
Drill	61982 5/8"	61982 5/8"	-	-
Drill Holder	36998	36998	-	-
Combined Drill and Holder	-	-	79185 3/4"	79185 3/4"
Boring Bar Adapter	-	-	36324	36324
Cutting Grease	88366	88366	88366	88366
Honing Stone	682560	682560	682560	682560
<b>Stopping</b>				
<b>MAOP†</b>	100 psig	100 psig	100 psig	100 psig
Machine Adapter	36195	36195	36195	36195
Reducing Bushing	36969 1-1/4" x 1"	36969 1-1/4" x 1"	-	-
Steel Shut Off Tool	45628	45628	36197	36197
Boring Bar Adapter	36324	36324	36324	36324
Rubber Shut Off Tool	88757	88757	88125	88125
Replacement Rubber	37454	37454	37629	37629
Rubber Shut Off Holder	36998	36998	36915	36915
Rubber Stopper Lubricant	580657	580657	580657	580657
<b>Inserting</b>				
<b>MAOP*</b>	100 psig	100 psig	100 psig	100 psig
Machine Adapter	36195	36195	36195	36195
Reducing Bushing	36969 1-1/4" x 1"	36969 1-1/4" x 1"	-	-
EZ Release Inserting Tool	83261	83261	83261	83261
Boring Bar Adapter	36324	36324	36324	36324
<b>Extracting</b>				
<b>MAOP*</b>	100 psig	100 psig	100 psig	100 psig
Machine Adapter	36195	36195	36195	36195
Reducing Bushing	36969 1-1/4" x 1"	36969 1-1/4" x 1"	-	-
Extracting Tool	88286	88286	88286	88286

\*Maximum Allowable Operating Pressure

†In stopping section of chart, Maximum Allowable Operating Pressure (MAOP) applies to use of rubber shut off tool only. For steel shut off tool, variables in hole drilled in pipe may or may not allow similar MAOP.

**D-5™/DH-5™ Machine**

<b>H-17504</b>	<b>1-1/4"</b>	<b>1-1/4"</b>	<b>2"</b>	<b>2"</b>	<b>2"</b>
Control Valve	H-10914 1-1/2"	H-10918 1-1/2"	H-10914 2"	H-10917 2"	H-10918 2"
Bushing	-	-	-	-	-
<b>Installation</b>					
Center Locating Punch	H-17615	H-17615	-	-	-
Test Cap	79161	79161	36811	36811	36811
Completion Plug Wrench	96536	96536	581264	581264	581264
<b>Drilling</b>					
<b>MAOP*</b>	100 psig	100 psig	100 psig	100 psig	100 psig
Power Operator	H-604	H-604	H-604	H-604	H-604
Machine Adapter	36196	36196	36188	36188	36188
Drill	33529 1"	33529 1"	-	-	-
Drill Holder	33555	33555	-	-	-
Shell Cutter	-	-	78910 1-1/2"	78910 1-1/2"	78910 1-1/2"
Shell Cutter Holder	-	-	33316	33316	33316
Cutter Holder Extension	-	-	-	-	63392
Cutting Grease	88366	88366	88366	88366	88366
Honing Stone	682560	682560	682560	682560	682560
<b>Stopping</b>					
<b>MAOP†</b>	100 psig	100 psig	100 psig	100 psig	100 psig
Machine Adapter	36196	36196	36188	36188	36188
Steel Shut Off Tool	33600	33600	36189	36189	36189
Rubber Shut Off Tool	88758	88758	88773	88773	88773
Replacement Rubber	37459	37459	37555	37555	37555
Holder for Rubber Shut Off Tool	61969	61969	33316	33316	33316
Boring Bar Adapter	36324	36324	-	-	-
Rubber Stopper Lubricant	580657	580657	580657	580657	580657
<b>Inserting</b>					
<b>MAOP*</b>	100 psig	100 psig	100 psig	100 psig	100 psig
Machine Adapter	36196	36196	36188	36188	36188
EZ Release Inserting Tool	83257	83257	83258	83258	83258
Boring Bar Adapter	36324	36324	36324	36324	36324
<b>Extracting</b>					
<b>MAOP*</b>	100 psig	100 psig	100 psig	100 psig	100 psig
Machine Adapter	36196	36196	36188	36188	36188
Extracting Tool	88286	88286	88384	88384	88384

\*Maximum Allowable Operating Pressure

†In stopping section of chart, Maximum Allowable Operating Pressure (MAOP) applies to use of rubber shut off tool only. For steel shut off tool, variables in hole drilled in pipe may or may not allow similar MAOP.

Rev. 6-10 Shaded area indicates changes

- Catalog number – **H-17530**
- Sizes\* – 2" x 2"
- Forged Steel Body ASTM A105
- Cast Iron Completion Cap ASTM A126 CL.B
- Cast Iron Completion Plug
- Weld inlet
- Insulating style compression connection outlet
- 175\*\* psig (1207 kPa)



**H-17530**

### How to select equipment

- 1) Find chart on following pages containing desired combination of fitting and installation machine (shown in bold type at top of each page and chart). Note: for a given fitting there may be more than one machine and chart.
- 2) Under inlet size of fitting to be installed, select catalog number for type of control valve to be used. Options may include one or more of the following: H-10914 Bronze Gate Valve, H-17025 Control Chamber, H-10917 Slide Gate Valve, H-10918 Steel Ball Valve.
- 3) Under selected control valve, column lists equipment necessary for each operation on chosen size of fitting. Note: **MAOP** (Maximum Allowed Operating Pressure) provided for **each** operation must not be exceeded. MAOP may be different for each operation.

### Dimensions

Dimensions	Size* of Service Tee
	2" x 2"
A	5-3/4"
B	3-3/4"
C	2"
D	1-1/2"

### Replacement Parts

Replacement Parts	Size* of Service Tee
	2" x 2"
Completion Cap	36310
Completion Plug	36356

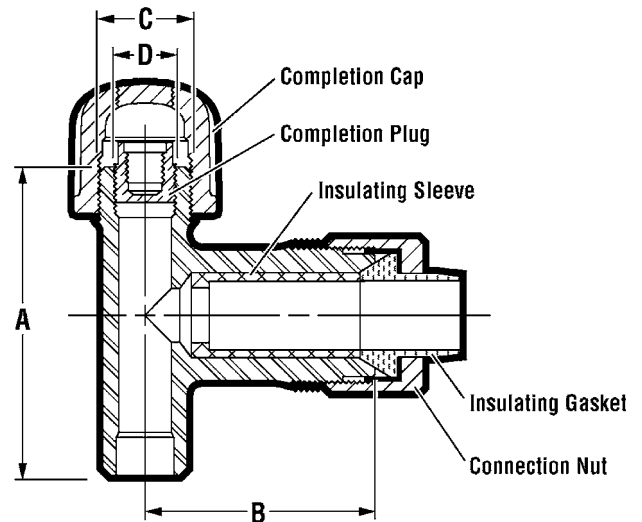

\*First size is size of inlet, second is size of outlet.

\*\*This is the maximum pressure of the fitting installed in the line at 100F for Class Locations 1, 2, 3 and 4 as defined in D.O.T./CFR TITLE 49 PART 192. It may be necessary to reduce the line pressure during the drilling, stopping or plugging operations to the maximum working pressure of the machine or its attachments. Refer to charts on following pages.



**E-5™/EH-5™ Machine**

<b>H-17530</b>	<b>2"</b>	<b>2"</b>	<b>2"</b>
Control Valve	H-10914 2"	H-10917 2"	H-10918 2"
Bushing	-	-	-
<b>Installation</b>			
Test Cap	36811	36811	36811
Completion Plug Wrench	581264	581264	581264
<b>Drilling</b>			
<b>MAOP*</b>	125 psig	175 psig	175 psig
Power Operator	H-604	H-604	H-604
Machine Adapter	78907	78907	582329
Shell Cutter	78910 1-1/2"	78910 1-1/2"	78910 1-1/2"
Shell Cutter Holder	78906	78906	501545
Shell Cutter Holder Extension	-	-	63392
Cutting Grease	88366	88366	88366
Honing Stone	682560	682560	682560
<b>Stopping</b>			
<b>MAOP†</b>	125 psig	175 psig	175 psig
Machine Adapter for Steel Shut Off Tool	78907	78907	528336
Steel Shut Off Tool	78902	78902	78902
Machine Adapter for Rubber Shut Off Tool	78907	78907	528329
Rubber Shut Off Tool	88773	88773	88773
Replacement Rubber	37555	37555	37555
Holder for Rubber Shut Off Tool	78906	78906	501545
Holder Extension for Rubber Shut Off Tool	-	-	63392
Rubber Stopper Lubricant	580657	580657	580657
<b>Inserting</b>			
<b>MAOP*</b>	125 psig	175 psig	175 psig
Machine Adapter	78907	78907	528329
EZ Release Inserting Tool	83258	83258	83258
<b>Extracting</b>			
<b>MAOP*</b>	125 psig	175 psig	175 psig
Machine Adapter	78907	78907	528329
Extracting Tool	80087	80087	83262

\*Maximum Allowable Operating Pressure

†In stopping section of chart, Maximum Allowable Operating Pressure (MAOP) applies to use of rubber shut off tool only. For steel shut off tool, variables in hole drilled in pipe may or may not allow similar MAOP.

**D-5™/DH-5™ Machine**

H-17530	2"	2"	2"
Control Valve	H-10914 2"	H-10917 2"	H-10918 2"
Bushing	-	-	-
<b>Installation</b>			
Test Cap	36811	36811	36811
Completion Plug Wrench	581264	581264	581264
<b>Drilling</b>			
<b>MAOP*</b>	125 psig	175 psig	175 psig
Power Operator	H-604	H-604	H-604
Machine Adapter	36188	36188	36188
Shell Cutter	78910 1-1/2"	78910 1-1/2"	78910 1-1/2"
Shell Cutter Holder	33316	33316	33316
Cutter Holder Extension	-	-	63392
Cutting Grease	88366	88366	88366
Honing Stone	682560	682560	682560
<b>Stopping</b>			
<b>MAOP†</b>	125 psig	175 psig	175 psig
Machine Adapter	36188	36188	36188
Steel Shut Off Tool	36189	36189	36189
Cutter Holder Extension	-	-	63392
Rubber Shut Off Tool	88773	88773	88773
Replacement Rubber	37555	37555	37555
Holder for Rubber Shut Off Tool	33316	33316	33316
Rubber Stopper Lubricant	580657	580657	580657
<b>Inserting</b>			
<b>MAOP*</b>	125 psig	175 psig	175 psig
Machine Adapter	36188	36188	36188
EZ Release Inserting Tool	83258	83258	83258
Boring Bar Adapter	36324	36324	36324
<b>Extracting</b>			
<b>MAOP*</b>	125 psig	175 psig	175 psig
Machine Adapter	36188	36188	36188
Extracting Tool	88384	88384	88384

\*Maximum Allowable Operating Pressure

†In stopping section of chart, Maximum Allowable Operating Pressure (MAOP) applies to use of rubber shut off tool only. For steel shut off tool, variables in hole drilled in pipe may or may not allow similar MAOP.

# MUELLER® NO-BLO® SERVICE TEE

## M.I.P. x WELD - 250 PIG

**Mueller Co.**

Reliable Connections™

# 3.27

Shaded area indicates change Rev. 6-10

- Catalog number – **H-17550**
- Sizes\* – 3/4" x 3/4", 1" x 1", 1-1/4" x 1-1/4", 2" x 2"
- Forged Steel Body ASTM A105
- Cast Iron Completion Cap ASTM A126 CL.B
- Cast Iron Completion Plug 2" x 2"
- External (M.I.P.) thread inlet
- Outlet prepared for butt weld same size as outlet and socket weld one size smaller than outlet
- 250\*\* psig (1724 kPa)



**H-17550**

### How to select equipment

- 1) Find chart on following pages containing desired combination of fitting and installation machine (shown in bold type at top of each page and chart). Note: for a given fitting there may be more than one machine and chart.
- 2) Under inlet size of fitting to be installed, select catalog number for type of control valve to be used. Options may include one or more of the following: H-10914 Bronze Gate Valve, H-17025 Control Chamber, H-10917 Slide Gate Valve, H-10918 Steel Ball Valve.
- 3) Under selected control valve, column lists equipment necessary for each operation on chosen size of fitting. Note: **MAOP** (Maximum Allowed Operating Pressure) provided for **each** operation must not be exceeded. MAOP may be different for each operation.

### Dimensions

Dimensions	Size* of Service Tee			
	3/4" x 3/4"	1" x 1"	1-1/4" x 1-1/4"	2" x 2"
A	4"	4-1/8"	4-3/8"	5-1/2"
B	1-3/4"	1-7/8"	2"	2-1/8"
C	1"	1-1/4"	1-1/2"	2"
D	1/2"	3/4"	1"	1-1/2"

### Replacement Parts

Replacement Parts	Size* of Service Tee			
	3/4" x 3/4"	1" x 1"	1-1/4" x 1-1/4"	2" x 2"
Completion Cap	34061	37483	38138	36310
Completion Plug	78898	34060	34122	36356

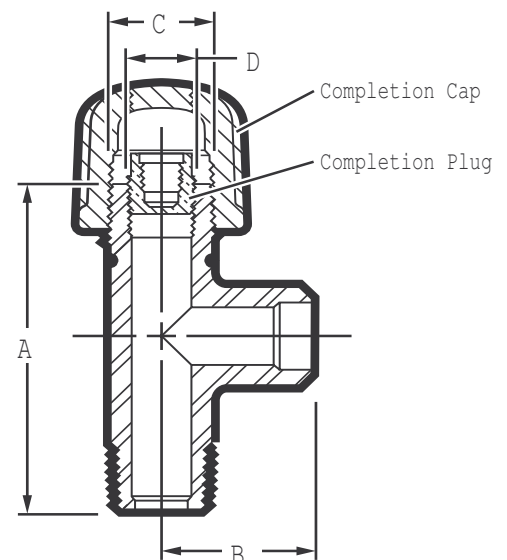

\*First size is size of inlet, second is size of outlet.

\*\*This is the maximum pressure of the fitting installed in the line at 100F for Class Locations 1, 2, 3 and 4 as defined in D.O.T./CFR TITLE 49 PART 192. It may be necessary to reduce the line pressure during the drilling, stopping or plugging operations to the maximum working pressure of the machine or its attachments. Refer to charts on following pages.

Rev. 12-06 Shaded area indicates changes

**E-5™/EH-5™ Machine**

H-17550	3/4"	3/4"	3/4"	1"	1"	1"
Control Valve	H-10914 1-1/4"	H-17025	H-10918 1-1/4"	H-10914 1-1/4"	H-17025	H-10918 1-1/4"
Bushing	-	78829 1"	-	-	78830 1-1/4"	-
<b>Installation</b>						
Center Locating Punch	H-17615	H-17615	H-17615	H-17615	H-17615	H-17615
Test Cap	79159	79159	79159	79160	79160	79160
Completion Plug Wrench	96536	96536	96536	96536	96536	96536
<b>Drilling</b>						
<b>MAOP*</b>	125 psig	125 psig	250 psig	125 psig	125 psig	250 psig
Power Operator	H-604	H-604	H-604	H-604	H-604	H-604
Machine Adapter	36733	-	36733	36733	-	36733
Reducing Bushing	36969 1-1/4"x1	-	36969 1-1/4"x1	-	-	-
Drill	61982 5/8"	61982 5/8"	61982 5/8"	-	-	-
Drill Holder	61981	61981	61981	-	-	-
Combined Drill and Holder	-	-	-	79185 3/4"	79185 3/4"	79185 3/4"
Cutting Grease	88366	88366	88366	88366	88366	88366
Honing Stone	682560	682560	682560	682560	682560	682560
<b>Stopping</b>						
<b>MAOP†</b>	125 psig	125 psig	250 psig	125 psig	125 psig	250 psig
Machine Adapter	36733	-	36733	36733	-	36733
Reducing Bushing	36969 1-1/4"x1	-	36969 1-1/4"x1	-	-	-
Steel Shut Off Tool	45628	45628	45628	36197	36197	36197
Rubber Shut Off Tool	88757	88757	88757	88125	88125	88125
Replacement Rubber	37454	37454	37454	37629	37629	37629
Holder for Rubber Shut Off Tool	61981	63396	61981	61789	61789	61789
Rubber Stopper Lubricant	580657	580657	580657	580657	580657	580657
<b>Inserting</b>						
<b>MAOP*</b>	125 psig	125 psig	250 psig	125 psig	125 psig	250 psig
Machine Adapter	36733	-	36733	36733	-	36733
Reducing Bushing	36969 1-1/4"x1	-	36969 1-1/4"x1	-	-	-
EZ Release Inserting Tool	83261	83261	83261	83261	83261	83261
<b>Extracting</b>						
<b>MAOP*</b>	125 psig	125 psig	250 psig	125 psig	125 psig	250 psig
Machine Adapter	36733	-	36733	36733	-	36733
Reducing Bushing	36969 1-1/4"x1	-	36969 1-1/4"x1	-	-	-
Extracting Tool	80088	80088	80088	80088	80088	80088

\*Maximum Allowable Operating Pressure

†In stopping section of chart, Maximum Allowable Operating Pressure (MAOP) applies to use of rubber shut off tool only. For steel shut off tool, variables in hole drilled in pipe may or may not allow similar MAOP.

**E-5™/EH-5™ Machine**

<b>H-17550</b>	<b>1-1/4"</b>	<b>1-1/4"</b>	<b>1-1/4"</b>	<b>2"</b>	<b>2"</b>	<b>2"</b>
Control Valve	H-10914 1-1/2"	H-17025	H-10918 1-1/2"	H-10914 2"	H-10917 2"	H-10918 2"
Bushing	-	78831 1-1/2"	-	-	-	-
<b>Installation</b>						
Center Locating Punch	H-17615	H-17615	H-17615	-	-	-
Test Cap	79161	79161	79161	36811	36811	36811
Completion Plug Wrench	96536	96536	96536	581264	581264	581264
<b>Drilling</b>						
<b>MAOP*</b>	125 psig	125 psig	250 psig	125 psig	250 psig	250 psig
Power Operator	H-604	H-604	H-604	H-604	H-604	H-604
Machine Adapter	33575	-	43892	78907	78907	528329
Combined Drill and Holder	79186 1"	79186 1"	79186 1"	-	-	-
Shell Cutter	-	-	-	78910 1-1/2"	78910 1-1/2"	78910 1-1/2"
Shell Cutter Holder	-	-	-	78906	78906	501545
Cutter Holder Extension	-	-	-	-	-	63392
Cutting Grease	88366	88366	88366	88366	88366	88366
Honing Stone	682560	682560	682560	682560	682560	682560
<b>Stopping</b>						
<b>MAOP†</b>	125 psig	125 psig	250 psig	125 psig	250 psig	250 psig
Machine Adapter for Steel Shut Off Tool	33575	-	43892	78907	78907	528336
Steel Shut Off Tool	33570	33570	-	78902	78902	78902
Machine Adapter for Rubber Shut Off Tool	33575	-	43892	78907	78907	528329
Rubber Shut Off Tool	88758	88758	88758	88773	88773	88773
Replacement Rubber	37459	37459	37459	37555	37555	37555
Holder for Rubber Shut Off Tool	61969	61969	61969	78906	78906	501545
Holder Extension for Rubber Shut Off Tool	-	-	-	-	-	63392
Rubber Stopper Lubricant	580657	580657	580657	580657	580657	580657
<b>Inserting</b>						
<b>MAOP*</b>	125 psig	125 psig	250 psig	125 psig	250 psig	250 psig
Machine Adapter	33575	-	43892	78907	78907	528329
EZ Release Inserting Tool	83261	83261	83261	83258	83258	83258
<b>Extracting</b>						
<b>MAOP*</b>	125 psig	125 psig	250 psig	125 psig	250 psig	250 psig
Machine Adapter	33575	-	43892	78907	78907	528329
Extracting Tool	80088	80088	80088	80087	80087	83262

\*Maximum Allowable Operating Pressure

†In stopping section of chart, Maximum Allowable Operating Pressure (MAOP) applies to use of rubber shut off tool only. For steel shut off tool, variables in hole drilled in pipe may or may not allow similar MAOP.

**D-5™/DH-5™ Machine**

H-17550	3/4"	3/4"	1"	1"
Control Valve	H-10914 1-1/4"	H-10918 1-1/4"	H-10914 1-1/4"	H-10914 1-1/4"
<b>Installation</b>				
Center Locating Punch	H-17615	H-17615	H-17615	H-17615
Test Cap	79159	79159	79160	79160
Completion Plug Wrench	96536	96536	96536	96536
<b>Drilling</b>				
<b>MAOP*</b>	125 psig	250 psig	125 psig	125 psig
Power Operator	H-604	H-604	H-604	H-604
Machine Adapter	36195	36195	36195	36195
Reducing Bushing	36969 1-1/4" x 1"	36969 1-1/4" x 1"	-	-
Drill	61982 5/8"	61982 5/8"	-	-
Drill Holder	36998	36998	-	-
Combined Drill & Holder	-	-	79185 3/4"	79185 3/4"
Boring Bar Adapter	-	-	36324	36324
Cutting Grease	88366	88366	88366	88366
Honing Stone	682560	682560	682560	682560
<b>Stopping</b>				
<b>MAOP†</b>	125 psig	250 psig	125 psig	125 psig
Machine Adapter	36195	36195	36195	36195
Reducing Bushing	36969 1-1/4" x 1"	36969 1-1/4" x 1"	-	-
Steel Shut Off Tool	46528	46528	36197	36197
Boring Bar Adapter for Steel Shut Off Tool	36324	36324	36324	36324
Rubber Shut Off Tool	88757	88757	88125	88125
Replacement Rubber	37454	37454	37629	37629
Holder for Rubber Shut Off Tool	36998	36998	36915	36915
Rubber Stopper Lubricant	580657	580657	580657	580657
<b>Inserting</b>				
<b>MAOP*</b>	125 psig	250 psig	125 psig	125 psig
Machine Adapter	36195	36195	36195	36195
Reducing Bushing	36969 1-1/4" x 1"	36969 1-1/4" x 1"	-	-
EZ Release Inserting Tool	83261	83261	83261	83261
Boring Bar Adapter	36324	36324	36324	36324
<b>Extracting</b>				
<b>MAOP*</b>	125 psig	250 psig	125 psig	125 psig
Machine Adapter	36195	36195	36195	36195
Reducing Bushing	36969 1-1/4" x 1"	36969 1-1/4" x 1"	-	-
Extracting Tool	88286	88286	88286	88286

\*Maximum Allowable Operating Pressure

†In stopping section of chart, Maximum Allowable Operating Pressure (MAOP) applies to use of rubber shut off tool only. For steel shut off tool, variables in hole drilled in pipe may or may not allow similar MAOP.

**D-5™/DH-5™ Machine**

<b>H-17550</b>	<b>1-1/4"</b>	<b>1-1/4"</b>	<b>2"</b>	<b>2"</b>	<b>2"</b>
Control Valve	H-10914 1-1/2"	H-10918 1-1/2"	H-10914 2"	H-10917 2"	H-10918 2"
Bushing	-	-	-	-	-
<b>Installation</b>					
Center Locating Punch	H-17615	H-17615	-	-	-
Test Cap	79161	79161	36811	36811	36811
Completion Plug Wrench	96536	96536	581264	581264	581264
<b>Drilling</b>					
<b>MAOP*</b>	125 psig	250 psig	125 psig	250 psig	250 psig
Power Operator	H-604	H-604	H-604	H-604	H-604
Machine Adapter	36196	36196	36188	36188	36188
Drill	33529 1"	33529 1"	33537 1-1/2"	33537 1-1/2"	33537 1-1/2"
Drill Holder	33555	33555	33316	33316	33316
Cutting Grease	88366	88366	88366	88366	88366
Honing Stone	682560	682560	682560	682560	682560
<b>Stopping</b>					
<b>MAOP†</b>	125 psig	250 psig	125 psig	250 psig	250 psig
Machine Adapter	36196	36196	36188	36188	36188
Steel Shut Off Tool	33600	33600	36189	36189	36189
Rubber Shut Off Tool	88758	88758	88773	88773	88773
Replacement Rubber	37459	37459	37555	37555	37555
Boring Bar Adapter for Rubber Shut Off Tool	36324	36324	-	-	-
Holder for Rubber Shut Off Tool	61969	61969	33316	33316	33316
Rubber Stopper Lubricant	580657	580657	580657	580657	580657
<b>Inserting</b>					
<b>MAOP*</b>	125 psig	250 psig	125 psig	250 psig	250 psig
Machine Adapter	36196	36196	36188	36188	36188
EZ Release Inserting Tool	83257	83257	83258	83258	83258
Boring Bar Adapter	36324	36324	36324	36324	36324
<b>Extracting</b>					
<b>MAOP*</b>	125 psig	250 psig	125 psig	250 psig	250 psig
Machine Adapter	36196	36196	36188	36188	36188
Extracting Tool	88286	88286	88384	88384	88384

\*Maximum Allowable Operating Pressure

†In stopping section of chart, Maximum Allowable Operating Pressure (MAOP) applies to use of rubber shut off tool only. For steel shut off tool, variables in hole drilled in pipe may or may not allow similar MAOP.

Rev. 6-10 Shaded area indicates changes

- Catalog number – **H-17560**
- Sizes\* – 1-1/4" X 1-1/4", 2" X 2"
- Forged Steel Body ASTM A105
- Cast Iron Completion Cap ASTM A126 CL.B
- Cast Iron Completion Plug 2" x 2"
- External (M.I.P.) thread inlet
- Extended outlet prepared for butt weld same size as outlet - for attaching compression connection
- 250\*\* psig (1724 kPa)



**H-17560**

### How to select equipment

- 1) Find chart on following pages containing desired combination of fitting and installation machine (shown in bold type at top of each page and chart). Note: for a given fitting there may be more than one machine and chart.
- 2) Under inlet size of fitting to be installed, select catalog number for type of control valve to be used. Options may include one or more of the following: H-10914 Bronze Gate Valve, H-17025 Control Chamber, H-10917 Slide Gate Valve, H-10918 Steel Ball Valve.
- 3) Under selected control valve, column lists equipment necessary for each operation on chosen size of fitting. Note: **MAOP** (Maximum Allowed Operating Pressure) provided for **each** operation must not be exceeded. MAOP may be different for each operation.

### Dimensions

Dimensions	Size* of Service Tee	
	1-1/4" x 1-1/4"	2" x 2"
A	4-3/8"	5-3/4"
B	3-1/2"	3-13/16"
C	1-1/2"	2"
D	1"	1-1/2"

### Replacement Parts

Replacement Parts	Size* of Service Tee	
	1-1/4" x 1-1/4"	2" x 2"
Completion Cap	38138	36310
Completion Plug	34122	36356

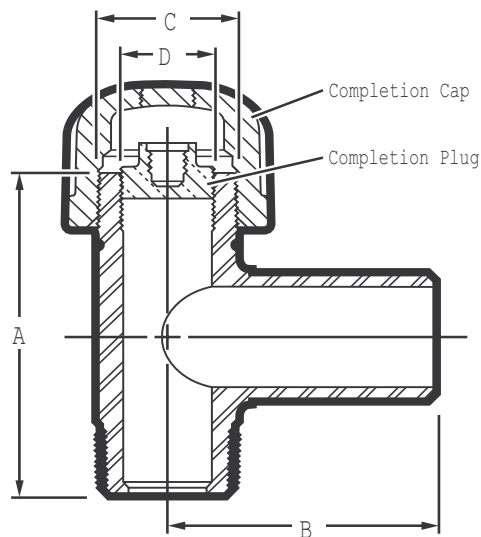

\*First size is size of inlet, second is size of outlet.

\*\*This is the maximum pressure of the fitting installed in the line at 100F for Class Locations 1, 2, 3 and 4 as defined in D.O.T./CFR TITLE 49 PART 192. It may be necessary to reduce the line pressure during the drilling, stopping or plugging operations to the maximum working pressure of the machine or its attachments. Refer to charts on following pages.



**E-5™/EH-5™ Machine**

<b>H-17560</b>	<b>1-1/4"</b>	<b>1-1/4"</b>	<b>1-1/4"</b>	<b>2"</b>	<b>2"</b>	<b>2"</b>
Control Valve	H-10914 1-1/2"	H-17025	H-10918 1-1/2"	H-10914 2"	H-10917 2"	H-10918 2"
Bushing	-	78831	-	-	-	-
<b>Installation</b>						
Center Locating Punch	H-17615	H-17615	H-17615	-	-	-
Test Cap	79161	79161	79161	36811	36811	36811
Completion Plug Wrench	96536	96536	96536	581264	581264	581264
<b>Drilling</b>						
<b>MAOP*</b>	125 psig	125 psig	250 psig	125 psig	250 psig	250 psig
Power Operator	H-604	H-604	H-604	H-604	H-604	H-604
Machine Adapter	33575	-	33575	78907	78907	528329
Combined Drill and Holder	79186 1"	79186 1"	79186 1"	-	-	-
Shell Cutter	-	-	-	78910 1-1/2"	78910 1-1/2"	78910 1-1/2"
Shell Cutter Holder	-	-	-	78906	78906	501545
Cutter Holder Extension	-	-	-	-	-	63392
Cutting Grease	88366	88366	88366	88366	88366	88366
Honing Stone	682560	682560	682560	682560	682560	682560
<b>Stopping</b>						
<b>MAOP†</b>	125 psig	125 psig	250 psig	125 psig	250 psig	250 psig
Machine Adapter for Steel Shut Off Tool	33575	-	43892	78907	78907	528336
Steel Shut Off Tool	33570	33570	-	78902	78902	78902
Machine Adapter for Rubber Shut Off Tool	33575	-	43892	78907	78907	528329
Rubber Shut Off Tool	88758	88758	88758	88773	88773	88773
Replacement Rubber	37459	37459	37459	37555	37555	37555
Holder for Rubber Shut Off Tool	61969	61969	61969	78906	78906	501545
Holder Extension for Rubber Shut Off Tool	-	-	--	-	-	63392
Rubber Stopper Lubricant	580657	580657	580657	580657	580657	580657
<b>Inserting</b>						
<b>MAOP*</b>	125 psig	125 psig	250 psig	125 psig	250 psig	250 psig
Machine Adapter	33575	-	43892	78907	78907	528329
EZ Release Inserting Tool	83261	83261	83261	83258	83258	83258
<b>Extracting</b>						
<b>MAOP*</b>	125 psig	125 psig	250 psig	125 psig	250 psig	250 psig
Machine Adapter	33575	-	43892	78907	78907	528329
Extracting Tool	80088	80088	80088	80087	80087	83262

\*Maximum Allowable Operating Pressure

†In stopping section of chart, Maximum Allowable Operating Pressure (MAOP) applies to use of rubber shut off tool only. For steel shut off tool, variables in hole drilled in pipe may or may not allow similar MAOP.

Rev. 9-15 Shaded area indicates changes

**D-5™/DH-5™ Machine**

H-17560	1-1/4"	1-1/4"	2"	2"	2"
Control Valve	H-10914 1-1/2"	H-10918 1-1/2"	H-10914 2"	H-10917 2"	H-10918 2"
Bushing	-	-	-	-	-
<b>Installation</b>					
Center Locating Punch	H-17615	H-17615	-	-	-
Test Cap	79161	79161	36811	36811	36811
Completion Plug Wrench	96536	96536	581264	581264	581264
<b>Drilling</b>					
MAOP*	125 psig	250 psig	125 psig	250 psig	250 psig
Power Operator	H-604	H-604	H-604	H-604	H-604
Machine Adapter	36196	36196	36188	36188	36188
Drill	33529 1"	33529 1"	33537 1-1/2"	33537 1-1/2"	33537 1-1/2"
Drill Holder	33555	33555	33316	33316	33316
Cutting Grease	88366	88366	88366	88366	88366
Honing Stone	682560	682560	682560	682560	682560
<b>Stopping</b>					
MAOP†	125 psig	250 psig	125 psig	250 psig	250 psig
Machine Adapter	36196	36196	36188	36188	36188
Steel Shut Off Tool	33600	33600	36189	36189	36189
Rubber Shut Off Tool	88758	88758	88773	88773	88773
Replacement Rubber	37549	37549	37555	37555	37555
Boring Bar Adapter	36324	36324	-	-	-
Holder for Rubber Shut Off Tool	61969	61969	33316	33316	33316
Rubber Stopper Lubricant	580657	580657	580657	580657	580657
<b>Inserting</b>					
MAOP*	125 psig	250 psig	125 psig	250 psig	250 psig
Machine Adapter	36196	36196	36188	36188	36188
EZ Release Inserting Tool	83257	83257	83258	83258	83258
Boring Bar Adapter	36324	36324	36324	36324	36324
<b>Extracting</b>					
MAOP*	125 psig	250 psig	125 psig	250 psig	250 psig
Machine Adapter	36196	36196	36188	36188	36188
Extracting Tool	88286	88286	88384	88384	88384

\*Maximum Allowable Operating Pressure

†In stopping section of chart, Maximum Allowable Operating Pressure (MAOP) applies to use of rubber shut off tool only. For steel shut off tool, variables in hole drilled in pipe may or may not allow similar MAOP.

# MUELLER® NO-BLO® SERVICE TEE

## M.I.P. x M.I.P. - 250 PSIG

**Mueller Co.**

Reliable Connections™

# 3.35

Shaded area indicates change Rev. 6-10

- Catalog number – **H-17570**
- Sizes\* – 3/4" x 3/4", 1" x 1", 1-1/4" x 1-1/4", 2" x 2"
- Forged Steel Body ASTM A105
- Cast Iron Completion Cap ASTM A126 CL.B
- Cast Iron Completion Plug 2" x2"
- External (M.I.P.) thread inlet
- External (M.I.P.) thread outlet
- 250\*\* psig (1724 kPa)



**H-17570**

### How to select equipment

- 1) Find chart on following pages containing desired combination of fitting and installation machine (shown in bold type at top of each page and chart). Note: for a given fitting there may be more than one machine and chart.
- 2) Under inlet size of fitting to be installed, select catalog number for type of control valve to be used. Options may include one or more of the following: H-10914 Bronze Gate Valve, H-17025 Control Chamber, H-10917 Slide Gate Valve, H-10918 Steel Ball Valve.
- 3) Under selected control valve, column lists equipment necessary for each operation on chosen size of fitting. Note: **MAOP** (Maximum Allowed Operating Pressure) provided for **each** operation must not be exceeded. MAOP may be different for each operation.

### Dimensions

Dimensions	Size* of Service Tee			
	3/4" x 3/4"	1" x 1"	1-1/4" x 1-1/4"	2" x 2"
A	4"	4-1/8"	4-3/8"	5-1/2"
B	1-3/4"	1-7/8"	2"	2-3/16"
C	1"	1-1/4"	1-1/2"	2"
D	1/2"	3/4"	1"	1-1/2"

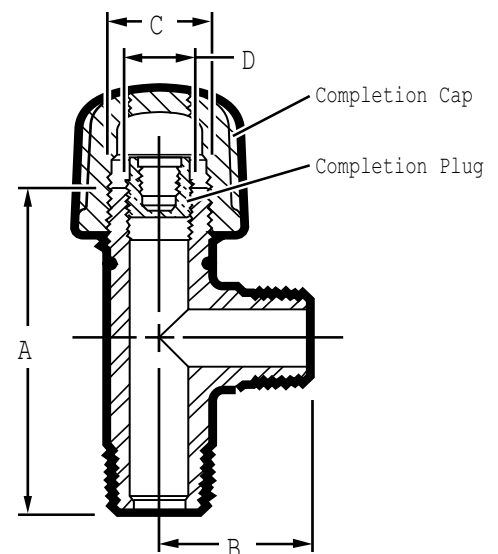

### Replacement Parts

Replacement Parts	Size* of Service Tee			
	3/4" x 3/4"	1" x 1"	1-1/4" x 1-1/4"	2" x 2"
Completion Cap	34061	37483	38138	36310
Completion Plug	78898	34060	34122	36356

\*First size is size of inlet, second is size of outlet.

\*\*This is the maximum pressure of the fitting installed in the line at 100F for Class Locations 1, 2, 3 and 4 as defined in D.O.T./CFR TITLE 49 PART 192. It may be necessary to reduce the line pressure during the drilling, stopping or plugging operations to the maximum working pressure of the machine or its attachments. Refer to charts on following pages.

**E-5™/EH-5™ Machine**

H-17570	3/4"	3/4"	3/4"	1"	1"	1"
Control Valve	H-10914 1-1/4"	H-17025	H-10918 1-1/4"	H-10914 1-1/4"	H-17025	H-10918 1-1/4"
Bushing	-	78829 1"	-	-	78830 1-1/4"	-
<b>Installation</b>						
Center Locating Punch	H-17615	H-17615	H-17615	H-17615	H-17615	H-17615
Test Cap	79159	79159	79159	79160	79160	79160
Completion Plug Wrench	96536	96536	96536	96536	96536	96536
<b>Drilling</b>						
<b>MAOP*</b>	125 psig	125 psig	250 psig	125 psig	125 psig	250 psig
Power Operator	H-604	H-604	H-604	H-604	H-604	H-604
Machine Adapter	36733	-	36733	36733	-	36733
Reducing Bushing	36969 1-1/4"x1	-	36969 1-1/4"x1	-	-	-
Drill	61982 5/8"	61982 5/8"	61982 5/8"	-	-	-
Drill Holder	61981	61981	61981	-	-	-
Combined Drill and Holder	-	-	-	79185 3/4"	79185 3/4"	79185 3/4"
Cutting Grease	88366	88366	88366	88366	88366	88366
Honing Stone	682560	682560	682560	682560	682560	682560
<b>Stopping</b>						
<b>MAOP†</b>	125 psig	125 psig	250 psig	125 psig	125 psig	250 psig
Machine Adapter	36733	-	36733	36733	-	36733
Reducing Bushing	36969 1-1/4"x1	-	36969 1-1/4"x1	-	-	-
Steel Shut Off Tool	45628	45628	45628	36197	36197	36197
Rubber Shut Off Tool	88757	88757	88757	88125	88125	88125
Replacement Rubber	37454	37454	37454	37629	37629	37629
Holder for Rubber Shut Off Tool	61981	63396	61981	61789	61789	61789
Rubber Stopper Lubricant	580657	580657	580657	580657	580657	580657
<b>Inserting</b>						
<b>MAOP*</b>	125 psig	125 psig	250 psig	125 psig	125 psig	250 psig
Machine Adapter	36733	-	36733	36733	-	36733
Reducing Bushing	36969 1-1/4"x1	-	36969 1-1/4"x1	-	-	-
EZ Release Inserting Tool	83261	83261	83261	83261	83261	83261
<b>Extracting</b>						
<b>MAOP*</b>	125	125	250	125	125	250
Machine Adapter	36733	-	36733	36733	-	36733
Reducing Bushing	36969 1-1/4"x1	-	36969 1-1/4"x1	-	-	-
Extracting Tool	80088	80088	80088	80088	80088	80088

\*Maximum Allowable Operating Pressure

†In stopping section of chart, Maximum Allowable Operating Pressure (MAOP) applies to use of rubber shut off tool only. For steel shut off tool, variables in hole drilled in pipe may or may not allow similar MAOP.

**E-5™/EH-5™ Machine**

<b>H-17570</b>	<b>1-1/4"</b>	<b>1-1/4"</b>	<b>1-1/4"</b>	<b>2"</b>	<b>2"</b>	<b>2"</b>
Control Valve	H-10914 1-1/2"	H-17025	H-10918 1-1/2"	H-10914 2"	H-10917 2"	H-10918 2"
Bushing	-	78831 1-1/2"	-	-	-	-
<b>Installation</b>						
Center Locating Punch	H-17615	H-17615	H-17615	-	-	-
Test Cap	79161	79161	79161	36811	36811	36811
Completion Plug Wrench	96536	96536	96536	581264	581264	581264
<b>Drilling</b>						
<b>MAOP*</b>	125 psig	125 psig	250 psig	125 psig	250 psig	250 psig
Power Operator	H-604	H-604	H-604	H-604	H-604	H-604
Machine Adapter	33575	-	43892	78907	78907	528329
Combined Drill and Holder	79186 1"	79186 1"	79186 1"	-	-	-
Shell Cutter	-	-	-	78910 1-1/2"	78910 1-1/2"	78910 1-1/2"
Shell Cutter Holder	-	-	-	78906	78906	501545
Cutter Holder Extension	-	-	-	-	-	63392
Cutting Grease	88366	88366	88366	88366	88366	88366
Honing Stone	682560	682560	682560	682560	682560	682560
<b>Stopping</b>						
<b>MAOP†</b>	125 psig	125 psig	250 psig	125 psig	250 psig	250 psig
Machine Adapter for Steel Shut Off Tool	33575	-	43892	78907	78907	528336
Steel Shut Off Tool	33570	33570	-	78902	78902	78902
Machine Adapter for Rubber Shut Off Tool	33575	-	43892	78907	78907	528329
Rubber Shut Off Tool	88758	88758	88758	88773	88773	88773
Replacement Rubber	37459	37459	37459	37555	37555	37555
Holder for Rubber Shut Off Tool	61969	61969	61969	78906	78906	501545
Holder Extension for Rubber Shut Off Tool	-	-	-	-	-	63392
Rubber Stopper Lubricant	580657	580657	580657	580657	580657	580657
<b>Inserting</b>						
<b>MAOP*</b>	125 psig	125 psig	250 psig	125 psig	250 psig	250 psig
Machine Adapter	33575	-	43892	78907	78907	528329
EZ Release Inserting Tool	83261	83261	83261	83258	83258	83258
<b>Extracting</b>						
<b>MAOP*</b>	125 psig	125 psig	250 psig	125 psig	250 psig	250 psig
Machine Adapter	33575	-	43892	78907	78907	528329
Extracting Tool	80088	80088	80088	80087	80087	83262

\*Maximum Allowable Operating Pressure

†In stopping section of chart, Maximum Allowable Operating Pressure (MAOP) applies to use of rubber shut off tool only. For steel shut off tool, variables in hole drilled in pipe may or may not allow similar MAOP.

**D-5™/DH-5™ Machine**

<b>H-17570</b>	<b>3/4"</b>	<b>3/4"</b>	<b>1"</b>	<b>1"</b>
Control Valve	H-10914 1-1/4"	H-10918 1-1/4"	H-10914 1-1/4"	H-10914 1-1/4"
<b>Installation</b>				
Center Locating Punch	H-17615	H-17615	H-17615	H-17615
Test Cap	79159	79159	79160	79160
Completion Plug Wrench	96536	96536	96536	96536
<b>Drilling</b>				
<b>MAOP*</b>	125 psig	250 psig	125 psig	125 psig
Power Operator	H-604	H-604	H-604	H-604
Machine Adapter	36195	36195	36195	36195
Reducing Bushing	36969 1-1/4" x 1"	36969 1-1/4" x 1"	-	-
Drill	61982 5/8"	61982 5/8"	-	-
Drill Holder	36998	36998	-	-
Combined Drill & Holder	-	-	79185 3/4"	79185 3/4"
Boring Bar Adapter	-	-	36324	36324
Cutting Grease	88366	88366	88366	88366
Honing Stone	682560	682560	682560	682560
<b>Stopping</b>				
<b>MAOP*</b>	125 psig	250 psig	125 psig	125 psig
Machine Adapter	36195	36195	36195	36195
Reducing Bushing	36969 1-1/4" x 1"	36969 1-1/4" x 1"	-	-
Steel Shut Off Tool	46528	46528	36197	36197
Boring Bar Adapter for Steel Shut Off Tool	36324	36324	36324	36324
Rubber Shut Off Tool	88757	88757	88125	88125
Replacement Rubber	37454	37454	37629	37629
Holder for Rubber Shut Off Tool	36998	36998	36915	36915
Rubber Stopper Lubricant	580657	580657	580657	580657
<b>Inserting</b>				
<b>MAOP*</b>	125 psig	250 psig	125 psig	125 psig
Machine Adapter	36195	36195	36195	36195
Reducing Bushing	36969 1-1/4" x 1"	36969 1-1/4" x 1"	-	-
EZ Release Inserting Tool	83261	83261	83261	83261
Boring Bar Adapter	36324	36324	36324	36324
<b>Extracting</b>				
<b>MAOP*</b>	125 psig	250 psig	125 psig	125 psig
Machine Adapter	36195	36195	36195	36195
Reducing Bushing	36969 1-1/4" x 1"	36969 1-1/4" x 1"	-	-
Extracting Tool	88286	88286	88286	88286

**D-5™/DH-5™ Machine**

<b>H-17570</b>	<b>1-1/4"</b>	<b>1-1/4"</b>	<b>2"</b>	<b>2"</b>	<b>2"</b>
Control Valve	H-10914 1-1/2"	H-10918 1-1/2"	H-10914 2"	H-10917 2"	H-10918 2"
Bushing	-	-	-	-	-
<b>Installation</b>					
Center Locating Punch	H-17615	H-17615	-	-	-
Test Cap	79161	79161	36811	36811	36811
Completion Plug Wrench	96536	96536	581264	581264	581264
<b>Drilling</b>					
<b>MAOP*</b>	125 psig	250 psig	125 psig	250 psig	250 psig
Power Operator	H-604	H-604	H-604	H-604	H-604
Machine Adapter	36196	36196	36188	36188	36188
Drill	33529 1"	33529 1"	33537 1-1/2"	33537 1-1/2"	33537 1-1/2"
Drill Holder	33555	33555	33316	33316	33316
Cutting Grease	88366	88366	88366	88366	88366
Honing Stone	682560	682560	682560	682560	682560
<b>Stopping</b>					
<b>MAOP*</b>	125 psig	250 psig	125 psig	250 psig	250 psig
Machine Adapter	36196	36196	36188	36188	36188
Steel Shut Off Tool	33600	33600	36189	36189	36189
Rubber Shut Off Tool	88758	88758	88773	88773	88773
Replacement Rubber	37549	37549	37555	37555	37555
Boring Bar Adapter for Rubber Shut Off Tool	36324	36324	-	-	-
Holder for Rubber Shut Off Tool	61969	61969	33316	33316	33316
Rubber Stopper Lubricant	580657	580657	580657	580657	580657
<b>Inserting</b>					
<b>MAOP*</b>	125 psig	250 psig	125 psig	250 psig	250 psig
Machine Adapter	36196	36196	36188	36188	36188
EZ Release Inserting Tool	83257	83257	83258	83258	83258
Boring Bar Adapter	36324	36324	36324	36324	36324
<b>Extracting</b>					
<b>MAOP*</b>	125 psig	250 psig	125 psig	250 psig	250 psig
Machine Adapter	36196	36196	36188	36188	36188
Extracting Tool	88286	88286	88384	88384	88384

\*Maximum Allowable Operating Pressure

Rev. 6-10 Shaded area indicates changes

- Catalog number – **H-17580**
- Sizes\* – 1-1/4" x 1-1/4", 2" x 2"
- Forged Steel Body ASTM A105
- Cast Iron Completion Cap ASTM A126 CL.B
- Cast Iron Completion Plug 2" x2"
- External (M.I.P.) thread inlet
- Insulated compression connection outlet
- 175\*\* psig (1207 kPa)



**H-17580**

### How to select equipment

- 1) Find chart on following pages containing desired combination of fitting and installation machine (shown in bold type at top of each page and chart). Note: for a given fitting there may be more than one machine and chart.
- 2) Under inlet size of fitting to be installed, select catalog number for type of control valve to be used. Options may include one or more of the following: H-10914 Bronze Gate Valve, H-17025 Control Chamber, H-10917 Slide Gate Valve, H-10918 Steel Ball Valve.
- 3) Under selected control valve, column lists equipment necessary for each operation on chosen size of fitting. Note: **MAOP** (Maximum Allowed Operating Pressure) provided for **each** operation must not be exceeded. MAOP may be different for each operation.

### Dimensions

Dimensions	Size* of Service Tee	
	1-1/4" x 1-1/4"	2" x 2"
A	4-3/4"	5-3/4"
B	3-3/8"	3-3/4"
C	1-1/2"	2"
D	1"	1-1/2"

### Replacement Parts

Replacement Parts	Size* of Service Tee	
	1-1/4" x 1-1/4"	2" x 2"
Completion Cap	38138	36310
Completion Plug	34122	36356

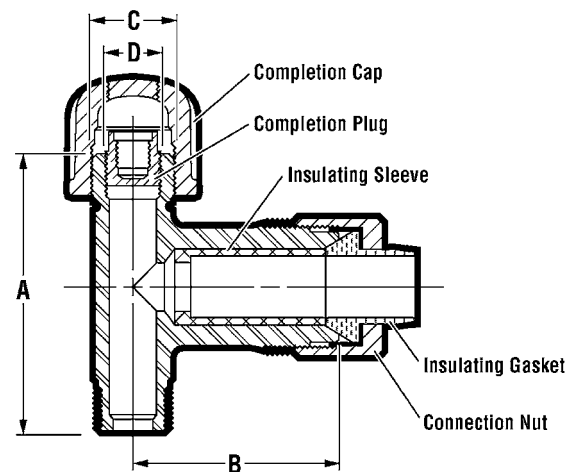

\*First size is size of inlet, second is size of outlet.

\*\*This is the maximum pressure of the fitting installed in the line at 100F for Class Locations 1, 2, 3 and 4 as defined in D.O.T./CFR TITLE 49 PART 192. It may be necessary to reduce the line pressure during the drilling, stopping or plugging operations to the maximum working pressure of the machine or its attachments. Refer to charts on following pages.



**E-5™/EH-5™ Machine**

<b>H-17580</b>	<b>1-1/4"</b>	<b>1-1/4"</b>	<b>1-1/4"</b>	<b>2"</b>	<b>2"</b>	<b>2"</b>
Control Valve	H-10914 1-1/2"	H-17025	H-10918 1-1/2"	H-10914 2"	H-10917 2"	H-10918 2"
Bushing	-	78831	-	-	-	-
<b>Installation</b>						
Center Locating Punch	H-17615	H-17615	H-17615	-	-	-
Test Cap	79161	79161	79161	36811	36811	36811
Completion Plug Wrench	96536	96536	96536	581264	581264	581264
<b>Drilling</b>						
<b>MAOP*</b>	125 psig	125 psig	175 psig	125 psig	175 psig	175 psig
Power Operator	H-604	H-604	H-604	H-604	H-604	H-604
Machine Adapter	33575	-	33575	78907	78907	528329
Combined Drill and Holder	79186 1"	79186 1"	79186 1"	-	-	-
Shell Cutter	-	-	-	78910 1-1/2"	78910 1-1/2"	78910 1-1/2"
Shell Cutter Holder	-	-	-	78906	78906	501545
Cutter Holder Extension	-	-	-	-	-	63392
Cutting Grease	88366	88366	88366	88366	88366	88366
Honing Stone	682560	682560	682560	682560	682560	682560
<b>Stopping</b>						
<b>MAOP†</b>	125 psig	125 psig	175 psig	125 psig	175 psig	175 psig
Machine Adapter for Steel Shut Off Tool	33575	-	43892	78907	78907	528336
Steel Shut Off Tool	33570	33570	-	78902	78902	78902
Machine Adapter for Rubber Shut Off Tool	33575	-	43892	78907	78907	528329
Rubber Shut Off Tool	88758	88758	88758	88773	88773	88773
Replacement Rubber	37459	37459	37459	37555	37555	37555
Holder for Rubber Shut Off Tool	61969	61969	61969	78906	78906	501545
Holder Extension for Rubber Shut Off Tool	-	-	-	-	-	63392
Rubber Stopper Lubricant	580657	580657	580657	580657	-580657	580657
<b>Inserting</b>						
<b>MAOP*</b>	125 psig	125 psig	175 psig	125 psig	175 psig	175 psig
Machine Adapter	33575	-	43892	78907	78907	528329
EZ Release Inserting Tool	83261	83261	83261	83258	83258	83258
<b>Extracting</b>						
<b>MAOP*</b>	125 psig	125 psig	175 psig	125 psig	175 psig	175 psig
Machine Adapter	33575	-	43892	78907	78907	528329
Extracting Tool	80088	80088	80088	80087	80087	83262

\*Maximum Allowable Operating Pressure

†In stopping section of chart, Maximum Allowable Operating Pressure (MAOP) applies to use of rubber shut off tool only. For steel shut off tool, variables in hole drilled in pipe may or may not allow similar MAOP.

**D-5™/DH-5™ Machine**

H-17580	1-1/4"	1-1/4"	2"	2"	2"
Control Valve	H-10914 1-1/2"	H-10918 1-1/2"	H-10914 2"	H-10917 2"	H-10918 2"
Bushing	-	-	-	-	-
<b>Installation</b>					
Center Locating Punch	H-17615	H-17615	-	-	-
Test Cap	79161	79161	36811	36811	36811
Completion Plug Wrench	96536	96536	581264	581264	581264
<b>Drilling</b>					
<b>MAOP*</b>	125 psig	175 psig	125 psig	175 psig	175 psig
Power Operator	H-604	H-604	H-604	H-604	H-604
Machine Adapter	36196	36196	36188	36188	36188
Drill	33529 1"	33529 1"	33537 1-1/2"	33537 1-1/2"	33537 1-1/2"
Drill Holder	33555	33555	33316	33316	33316
Cutting Grease	88366	88366	88366	88366	88366
Honing Stone	682560	682560	682560	682560	682560
<b>Stopping</b>					
<b>MAOP†</b>	125 psig	175 psig	125 psig	175 psig	175 psig
Machine Adapter	36196	36196	36188	36188	36188
Steel Shut Off Tool	33600	33600	36189	36189	36189
Rubber Shut Off Tool	88758	88758	88773	88773	88773
Replacement Rubber	37549	37549	37555	37555	37555
Boring Bar Adapter	36324	36324	-	-	-
Holder for Rubber Shut Off Tool	61969	61969	33316	33316	33316
Rubber Stopper Lubricant	580657	580657	580657	580657	580657
<b>Inserting</b>					
<b>MAOP*</b>	125 psig	175 psig	125 psig	175 psig	175 psig
Machine Adapter	36196	36196	36188	36188	36188
EZ Release Inserting Tool	83257	83257	83258	83258	83258
Boring Bar Adapter	36324	36324	36324	36324	36324
<b>Extracting</b>					
<b>MAOP*</b>	125 psig	175 psig	125 psig	175 psig	175 psig
Machine Adapter	36196	36196	36188	36188	36188
Extracting Tool	88286	88286	88384	88384	88384

\*Maximum Allowable Operating Pressure

†In stopping section of chart, Maximum Allowable Operating Pressure (MAOP) applies to use of rubber shut off tool only. For steel shut off tool, variables in hole drilled in pipe may or may not allow similar MAOP.