

March 2017

# 289 Series Relief Valves

## WARNING

Failure to follow these instructions or to properly install and maintain this equipment could result in an explosion and/or fire causing property damage and personal injury or death.

Fisher™ relief valves must be installed, operated and maintained in accordance with federal, state and local codes, rules and regulations and manufacturer's instructions.

If a leak develops or if the outlet continually vents gas, service to the unit may be required. Failure to correct trouble could result in a hazardous condition. Only a qualified person must install or service the unit.

Call a gas service person to service the unit. Only a qualified person must install or service the regulator.

## Introduction

### Scope of the Manual

This manual provides instructions for installation, maintenance and parts ordering information for the 289 Series relief valves. Instructions for other equipment used with these relief valves can be found in separate instruction manuals.

### Description

The 289 Series pressure relief valves (see Figure 1) are throttling relief valves used downstream of pressure regulators to protect the downstream system from overpressure. These relief valves can be used for natural gas, air, propane or other noncorrosive, gas-flow service.



2 NPT TYPE 289H



1 NPT TYPE 289H

*Figure 1. Type 289H Relief Valves*

# 289 Series

## Specifications

This section lists the specifications for the 289 Series regulators. Factory specification are stamped on the nameplate fastened on the regulator at the factory.

<b>Available Configurations</b> See Table 1	<b>Pressure Setting Adjustment</b> Adjusting screw
<b>Body Sizes and Inlet Connections</b> <b>Type 289L:</b> 3/4 or 1 NPT <b>Types 289A and 289U:</b> 1/4 NPT <b>Type 289H:</b> 1 or 2 NPT <b>Type 289HH:</b> 1 NPT	<b>Pressure Registration</b> Internal
<b>Maximum Allowable Relief (Inlet) Pressure<sup>(1)</sup> and Maximum Relief Set Pressure</b> See Table 1	<b>Approximate Shipping Weights</b> <b>Types 289A and 289U:</b> 0.75 lbs / 0.3 kg <b>Type 289H:</b> 1 NPT Size: 4 lbs / 2.0 kg 2 NPT Size: 15 lbs / 7.0 kg <b>Type 289HH:</b> 4 lbs / 2.0 kg <b>Type 289L:</b> 15 lbs / 7.0 kg
<b>Material Temperature Capabilities<sup>(1)</sup></b> <b>Nitrile (NBR) and Neoprene (CR):</b> -20 to 150°F / -29 to 66°C <b>Fluorocarbon (FKM)<sup>(2)</sup>:</b> 20 to 300°F / -7 to 149°C <b>Available with Types 289H and 289HH only</b>	<b>Additional Specifications</b> For construction materials, see Parts List.

1. The pressure/temperature limits in this Instruction Manual and any applicable standard limitation should not be exceeded.  
2. Bubble-tight shutoff cannot be attained at settings below 5 psig / 0.34 bar with Fluorocarbon (FKM) O-ring seat.

## Principle of Operation

Refer to Figures 2 and 4. The 289 Series Relief valves are to be installed (between large service regulators such as S202G or S302G Series) so the outlet is piped downstream to relieve excess pressure to the atmosphere. As inlet pressure increases, the spring is compressed by the diaphragm, moving the disk away from the seat. When the valve is opening, high gas velocity through the orifice creates an area of relatively low pressure near the end of the pitot tube. This pitot tube effect forms a partial vacuum above the diaphragm (spring case area) which helps to open the valve further.

## Installation



### WARNING

**Installing a 289 Series relief valve where its capabilities can be exceeded or where proper operation might be impaired may cause personal injury, property damage or leakage due to bursting of pressure-containing parts or explosion of accumulated gas. To avoid such**

**conditions, install a 289 Series relief valve where:**

- **Service conditions are within the unit capabilities specified in the Specifications section and**
- **The relief valve is protected from exposure to physical damage and/or corrosive substances.**

1. When installing a 289 Series relief valve, make sure that the installation of the system complies with applicable local, state or federal codes or regulations.
2. Use qualified personnel when installing, operating and maintaining a 289 Series relief valve. Before installation, make sure there is no damage to or foreign material in the relief valve and that all piping is clean and unobstructed.
3. For installation of Types 289H, 289HH and 289L relief valves, the vent in the spring case must remain plugged or undrilled in order for the pitot tube to function properly.
4. The 289 Series relief valves may be installed in any orientation. However, when installing the relief valve at an outside location, adequate protection, such as rain caps or elbow piping (see Figure 4), must be attached to the outlet to keep the relief valve from getting plugged or from collecting moisture, corrosive

chemicals or other foreign materials. If piping is to be attached to the valve outlet, the following parts (if they are connected to the valve outlet as shown in Figures 6 through 10) must first be removed: the screen (key 9), the snap ring (key 13) and the gasket (key 15). A typical installation of a 289 Series relief valve is shown in Figure 4.

## WARNING

**If using a 289 Series relief valve on hazardous or flammable gas service, personal injury and property damage could occur due to fire or explosion of vented gas that may have accumulated.**

**To prevent such injury or damage, provide piping or tubing to vent the gas to a safe, well-ventilated area. Also, when venting a hazardous gas, the piping or tubing should be located far enough away from any buildings or windows so to not create a further hazard and the vent opening should be protected against anything that could clog it.**

5. Apply pipe compound to the male pipeline threads only; do not apply pipe compound to the internal body threads. Then install the relief valve so that the flow through it will match the direction arrow or marking cast on the valve body.

When installing the molded diaphragm in the 289 Series Relief Valves, make sure the diaphragm convolutions is installed in the down position as shown in Figure 3.

## Startup

Key numbers are shown in Figures 6 through 10. With proper installation completed and system equipment properly adjusted, close any vent valves and slowly open the upstream shutoff valve while using pressure gauges to monitor pressure.

### Note

**To ensure proper operation of the pitot tube, if present, the spring case (key 2) must be tightly sealed. It is recommended that the gasket (key 15) be replaced whenever the closing cap (key 14) is removed. Antiseizing sealant should be applied to the adjusting screw (key 6) threads on valves without closing caps.**

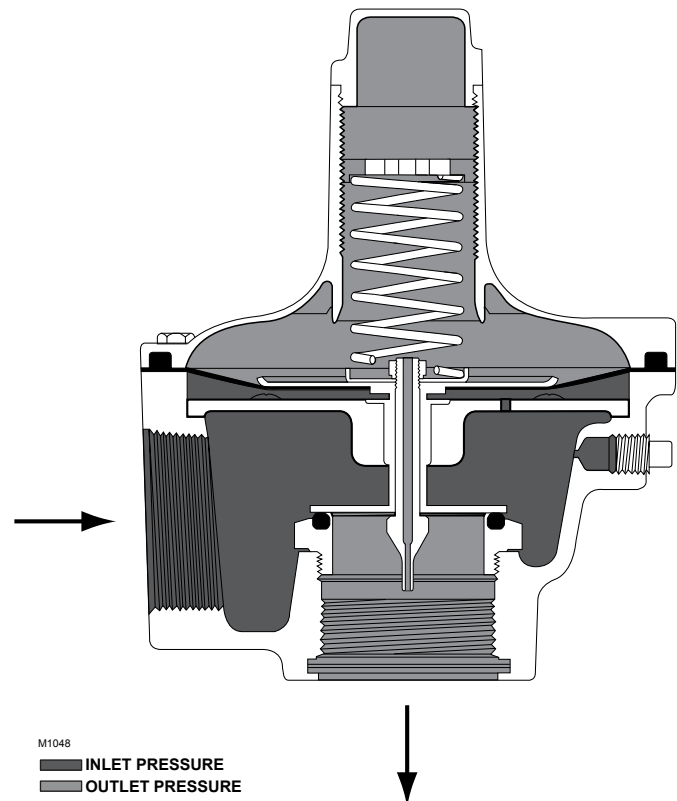

Figure 2. 2 NPT Type 289H Operational Schematic

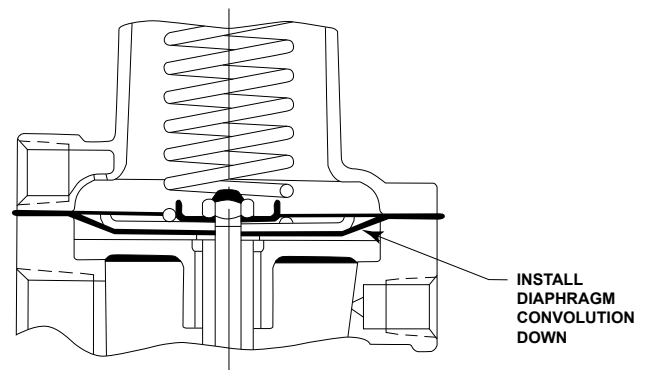
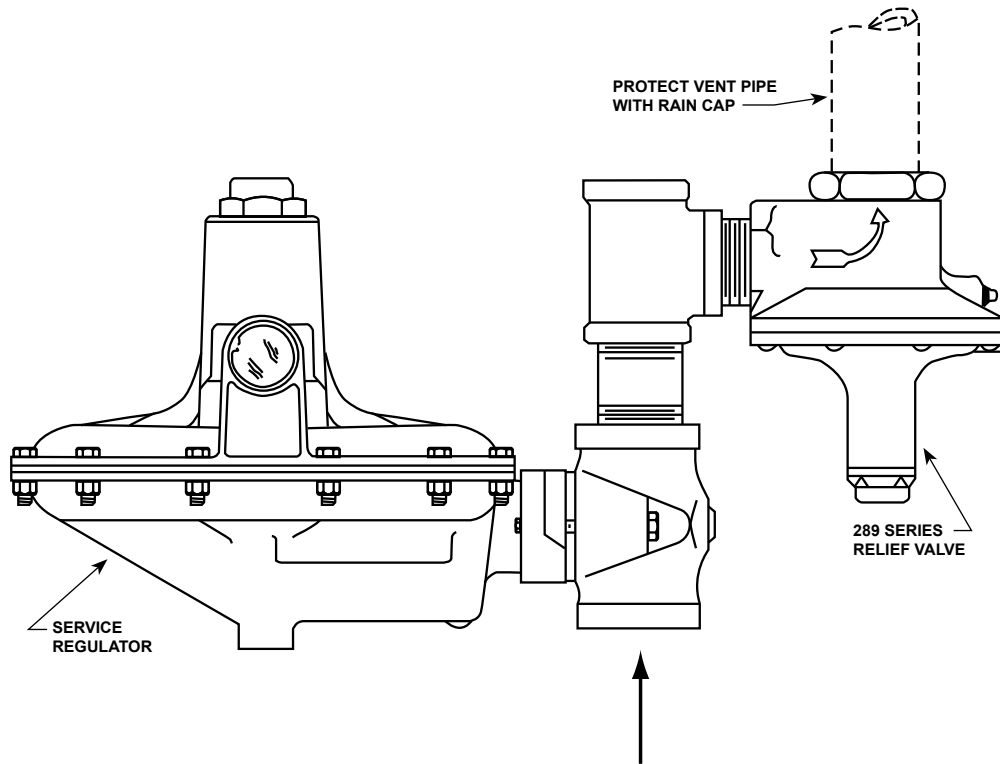

Figure 3. Installation of Diaphragm

**Set point verification should be included in startup procedures.** If set pressure adjustment is necessary, monitor the inlet pressure with a gauge during the adjustment procedure. Remove the closing cap (key 14) or loosen the hex nut (key 11) and turn the adjusting screw (key 6) clockwise to increase or counterclockwise to decrease the relief pressure setting.



AJ4698-C  
A2404-1

**Figure 4.** Typical Installation

For 2 NPT Type 289H relief valves, when changing from one spring range to another, it is recommended that a new spring case be used so that the travel stop drive screw will be positioned correctly for the corresponding spring range. Each spring range requires that the travel stop drive screw be positioned appropriately in the spring case to prevent setting the relief valve pressure too high. The location of the travel stop drive screw for each spring and spring range is shown in Figure 5.

## Shutdown

Close the upstream shutoff valve and release all pressure from the relief valve.

## Maintenance

Relief valve parts are subject to normal wear and should be inspected periodically for maintenance. The frequency of inspection and replacement of parts depends upon the severity of service conditions.

This section contains information for inspection and maintenance of 289 Series relief valves.

Maintenance procedures are presented for relief valve configurations of similar construction. Refer to the appropriate procedure and Figure for the particular relief valve configuration when changing the control spring to one of a different range or when inspecting, cleaning or replacing any other relief valve parts. The screen (key 9, Figures 6 through 9) and vent piping, if present, should be free of foreign material that might impair relief flow.

It is recommended that a good quality pipe thread sealant be applied to pressure connections and fittings and a good quality lubricant be applied to all O-rings. Also apply an anti-seize compound to the adjusting screw threads and other areas as needed. Reference Figures 6 through 10 to determine the recommended lubricant/sealant/adhesive for these parts. All lubricants/sealants/adhesives must be selected such that they meet the temperature requirements.

### Note

**The relief valve body (key 1, Figures 6 through 10) may remain in the pipeline during maintenance unless replacement of the valve body is necessary.**

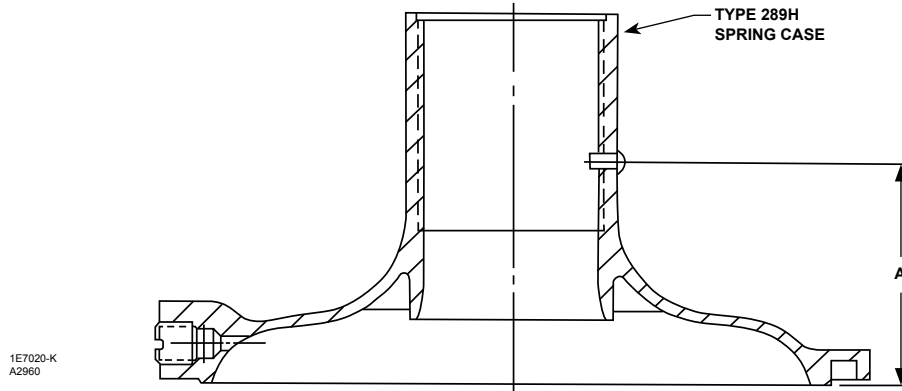

**Figure 5.** Location of Travel Stop Drive Screw for 2 NPT Type 289H Relief Valve

**Table 1.** Maximum Allowable Relief (Inlet) Pressure

AVAILABLE CONFIGURATION	BODY SIZE, NPT	SPRING PART NUMBER	COLOR CODE	SPRING RANGE (RELIEF PRESSURE SETTINGS)		MAXIMUM ALLOWABLE RELIEF (INLET) PRESSURE <sup>(1)</sup>	
				psig	bar	psig	bar
Type 289A	1/4	0Z056327022 1B268227022	Silver Silver	3 to 13 11 to 22	0.21 to 0.90 0.76 to 1.5	45	3.1
Type 289H	1	1F826927052 1D892327022 1D751527022 1D7455T0012	Pink Red Silver Green	1 to 4.5 4 to 15 10 to 20 15 to 50	0.07 to 0.31 0.28 to 1.0 0.69 to 1.4 1.0 to 3.5	100	6.9
	2	1B536527052 1B536627052 1B536827062 1B536927052	Dark blue Gray Dark green Red Stripe	7 to 18 in. w.c. 0.5 to 2.25 1.75 to 7 4 to 10	17 to 45 mbar 0.03 to 0.16 0.12 to 0.48 0.28 to 0.69	25	1.7
Type 289HH	1	1D7455T0012	Green	45 to 75	3.1 to 5.2	100	6.9
Type 289L	3/4 or 1	13A7917X012 13A7916X012	Silver Red Stripe	10 to 18 in. w.c. 12 to 40 in. w.c	25 to 45 mbar 30 to 99 mbar	7	0.48
Type 289U	1/4	0V060227022 0F058227022	Silver Silver	5 to 25 in. w.c. 20 in. w.c. to 3 psig	12 to 62 mbar 50 to 207 mbar	10	0.69

1. This value indicates the relief pressure setting plus pressure build-up.

**Table 2.** Relief Set Pressure Ranges

SPRING PART NUMBER	SPRING RANGE (RELIEF PRESSURE SETTING)		DIMENSION A	
	psig	bar	In.	mm
1B536527052	7 to 18 in. w.c.	17 to 45 mbar	Drive screw not required	
1B536627052	0.5 to 2.25	0.03 to 0.16	1-17/32	39
1B536827062	1.75 to 7	0.12 to 0.48	2-5/32	55
1B536927052	4 to 10	0.28 to 0.69	2-5/16	59



## WARNING

**Avoid personal injury or property damage from sudden release of pressure or explosion of accumulated gas. Before starting disassembly:**

- Isolate the relief valve from line pressure and
- Release trapped pressure from the valve body and pressure line.

### Type 289A

All key numbers are shown in Figure 6.

1. Loosen the hex nut (key 11) and unscrew the adjusting screw (key 6) to relieve spring compression.
2. Unscrew the machine screws (key 8) and remove the spring case (key 2), the spring seat (key 4), the spring (key 7), the diaphragm head (key 3) and the diaphragm (key 5).
3. Inspect the diaphragm and seating surfaces for damage or wear and replace parts as necessary. To remove the orifice (key 10) unscrew it from the body.
4. Reinstall the orifice, the diaphragm, the diaphragm head, the spring and the spring seat.
5. Reattach the spring case using the machine screws.
6. If a new spring with a different range is installed, stamp the spring case with the new spring range.
7. Adjust the spring compression according to the procedures outlined in the Startup section.

### Type 289U

All key numbers are shown in Figure 7.

1. Loosen the hex nut (key 11) and unscrew the adjusting screw (key 6) to relieve spring compression.
2. Unscrew the machine screws (key 8) and remove the spring case (key 2), the spring seat (key 4), the spring (key 7) and the diaphragm assembly (key 5).
3. Inspect the diaphragm assembly and seating surfaces for damage or wear and replace parts as necessary.
4. Reinstall the diaphragm assembly, the spring and the spring seat.

5. Reattach the spring case using the machine screws.
6. If a new spring with a different range is installed, stamp the spring case with the new spring range.
7. Adjust the spring compression according to the procedures outlined in the Startup section.

### Type 289L

All key numbers are shown in Figure 8.

1. Remove the closing cap (key 14) and the gasket (key 15) and then unscrew the adjusting screw (key 6) to relieve spring compression.
2. Unscrew the machine screws (key 8) and then remove the spring case (key 2), the spring (key 7) and the diaphragm assembly (key 5).
3. Inspect the diaphragm and seating surfaces for damage or wear and replace parts as necessary. To remove the orifice (key 10), unscrew it from the body. Check the pitot tube in the diaphragm assembly for blockage and remove any foreign material that might impair proper operation of the relief valve.
4. Reinstall the orifice, the diaphragm assembly and the spring.
5. Reattach the spring case using the machine screws.
6. If a new spring with a different range is installed, stamp the closing cap with the new spring range.
7. Adjust the spring compression according to the procedures outlined in the Startup section and then reinstall the closing cap and gasket.

### Types 289HH and 1 NPT 289H

All key numbers are shown in Figure 9.

1. Loosen the hex nut (key 11) and then unscrew the adjusting screw (key 6) to relieve spring compression.
2. Unscrew the machine screws (key 8) and remove the spring case (key 2), the spring seat (key 4) and the spring (key 7).
3. Unscrew the hex nut (key 24) and remove the lower spring seat (key 17), the diaphragm head (key 3) and the diaphragm (key 5).
4. Unscrew the machine screws (key 29) and then remove the stem guide assembly (key 31) and attached parts from the valve body (key 1).

5. Slide the spacer (key 23) and the pitot tube (key 18) and attached parts from the valve body.
6. Remove the washer (key 27), the gasket (key 19), the spacer, the O-rings (key 30), the O-ring holder (key 21), the O-ring (key 20) and the O-ring washer (key 22) from the pitot tube.
7. Inspect the O-rings, the gaskets, the spacer, the orifice and the seating surfaces for damage or wear and replace parts as necessary.
8. Apply anti-seizing sealant to the adjusting screw threads and to the end of the adjusting screw that contacts the spring seat.
9. Slide the O-ring washer, the O-rings (keys 30 and 20), the O-ring holder, the O-ring (key 30), the spacer, the stem guide assembly, the gasket and the washer (key 27) onto the pitot tube.
10. Reinstall the stem guide assembly with attached parts into the valve body and then attach this assembly with the machine screws (key 29).
11. Replace the diaphragm, the diaphragm head and the lower spring seat and then secure these parts with the hex nut (key 24).
12. Reinstall the spring and the spring seat and then attach the spring case to the valve body using the machine screws (key 8).
13. If a new spring with a different range is installed, stamp the spring case with the new spring range.
14. Adjust the spring compression according to the procedures outlined in the Startup section.
6. Slide the spacer (key 23) and the pitot tube (key 18) and attached parts out of the stem guide assembly.
7. Remove the gaskets (key 19), the spacer (key 23) and the O-ring washer (key 22) from the pitot tube. Then remove the O-ring washer (key 22) and the orifice (key 10) from the valve body (key 1).
8. Inspect the O-rings, the gaskets, the spacer, the orifice and the seating surfaces for damage or wear and replace parts as necessary.
9. Apply anti-seizing sealant to the orifice threads and then to the adjusting screw threads.
10. Reinstall the orifice and the O-ring (key 20) into the valve body.
11. Slide the gasket, the O-ring washer, the gasket, the spacer, the stem guide assembly and the gasket onto the pitot tube.
12. Reinstall the stem guide assembly with attached parts into the valve body and attach it with the machine screws (key 29).
13. Replace the lower diaphragm head, the diaphragm, the diaphragm head and the lower spring seat; then secure these parts with the hex nut (key 11). Screw in the lifting stem and lock it in place with the hex nut (key 24).
14. Reinstall the spring and the washer.

#### Note

**For 2 NPT Type 289H relief valves, when changing from one spring range to another, use a new spring case to position the travel stop drive screw correctly for the corresponding spring range. Each spring range requires that the travel stop drive screw be positioned appropriately in the spring case to prevent setting the relief valve pressure too high. The location of the travel stop drive screw for each spring and spring range is shown in Figure 5.**

## 2 NPT Type 289H

All key numbers are shown in Figure 10.

1. Remove the closing cap and the gasket (keys 14 and 15) and then unscrew the adjusting screw (key 6) to relieve spring compression.
2. Unscrew the machine screw (key 8) and remove the spring case (key 2), the washer (key 27) and the spring (key 7).
3. Unscrew the hex nut (key 24), unscrew the lifting stem (key 25) and then unscrew the hex nut (key 11).
4. Remove the lower spring seat (key 17), the diaphragm head (key 3), the diaphragm (key 5), the lower diaphragm head (key 26) and the gasket (key 19).
5. Unscrew the machine screws (key 29) and then remove the stem guide assembly (key 31) and attached parts.
15. Attach the spring case to the valve body using the machine screws (key 8).
16. If a new spring with a different range is installed, stamp the spring case with the new spring range.
17. Adjust the spring compression according to the procedures outlined in the Startup section. Then install the gasket and the closing cap.

# 289 Series

## Parts Ordering

When corresponding with your local Sales Office about this equipment, always reference the equipment serial number stamped on the spring case (key 2) or the closing cap (key 14). When ordering replacement parts, specify the complete 11-character part number of each required part as found in the following parts list.

## Parts List

Key	Description	Part Number
	Parts Kit (included are keys 5, 9, 15, 19, 20, 30 and 38). Screen is Stainless steel and gaskets are composition and Neoprene (CR). Type 289A (include keys 5 and 9 only) Neoprene (CR) diaphragm Type 289L (include keys 5, 9 and 15 only) Nitrile (NBR) diaphragm and O-rings 3/4 NPT body 1 NPT body Types 289H (1 NPT body) and 289HH Nitrile (NBR) diaphragm and O-rings Fluorocarbon (FKM) diaphragm and O-rings Type 289H, 2 NPT body (include keys 5, 9, 15, 19, 20 and 38) Nitrile (NBR) diaphragm and O-rings Fluorocarbon (FKM) diaphragm and O-rings Type 289U (include keys 5 and 9 only) Nitrile (NBR) diaphragm	R289AX00012 R289LX00012 R289LX00022 R289HX00012 R289HX00032 R289HX00022 R289HX00042 R289UX00012
1	Valve Body Type 289A, Zinc Type 289U, Zinc Types 289H (1 NPT body) and 289HH, Aluminum Type 289H (2 NPT body), Cast iron Type 289L, Aluminum 3/4 NPT body 1 NPT body	0Y071044022 0B043844012 3U888208012 31B1992X012 3L407008012 3L406908012
2	Spring Case/Spring Case Assembly Type 289A, Zinc Types 289H (1 NPT body) and 289HH, Aluminum Type 289H (2 NPT body), Zinc/steel Type 289L, Aluminum Type 289U, Zinc	0B061644022 1P901708012 1E7020X0012 3L3338X0012 0B061644022
3	Diaphragm Head Type 289A, Aluminum Type 289H, Zinc-plated steel 1 NPT body 2 NPT body Type 289HH, Zinc-plated steel	0T022744022 1D666428982 0W020225072 1P901425062
4	Spring Seat Type 289L, Zinc-plated steel Type 289A, Brass Type 289U, Zinc-plated steel Types 289H (1 NPT body) and 289HH, Zinc-plated steel	1L406525072 0T022614012 1B372544022 1D667125072
5*	Diaphragm/Diaphragm Assembly Type 289A, Neoprene (CR) Types 289H (1 NPT body) and 289HH Nitrile (NBR) Fluorocarbon (FKM)	1A505202102 24B5622X012 1E606602342

Key	Description	Part Number
5*	Diaphragm/Diaphragm Assembly (continued) Type 289H (2 NPT body) Nitrile (NBR) Fluorocarbon (FKM) Type 289L Nitrile (NBR) <sup>(1)</sup> , 3/4 and 1 NPT bodies, (standard) Type 289U <sup>(2)</sup> , Nitrile (NBR)	24B6447X012 1D780002332 AL4068X0062 18A2815X012
6	Adjusting Screw Type 289A, Brass Types 289H (1 NPT body) and 289HH, Zinc-plated steel Type 289H (2 NPT body), Zinc Type 289L, Delrin® Type 289U, Brass	1A568414012 1D995448702 1B537944012 T1007106642 0F058114012
7	Spring	See Table 1
8	Machine Screw, Plated steel Type 289A (6 required) Types 289H and 289HH, 1 NPT body, (8 required) Type 289H, 2 NPT body (8 required) Type 289L (8 required) Type 289U (6 required)	1P474328982 1A391724052 1A407824052 T13305T0012 1A899028982
9	Screen, Stainless steel Type 289L 3/4 NPT body 1 NPT body Types 289A and 289U Types 289H and 289HH, 1 NPT body Type 289H, 2 NPT body	1B633538392 1E564843122 0L078343062 1E564843122 11B1994X012
10*	Orifice Type 289A, Aluminum Type 289H (2 NPT body) Brass Stainless steel Type 289L, Aluminum	0T022509012 1E702613012 1E702635072 1L406409012
11	Hex Nut Types 289A and 289U, Brass Types 289H (1 NPT body) and 289HH, Zinc-plated steel Type 289H (2 NPT body) Zinc-plated steel Zinc	1A505418992 1D667728982 1D780124272 1A309324122
13	Snap Ring Type 289L, Stainless steel 3/4 NPT body 1 NPT body Types 289H and 289HH, 1 NPT body, Carbon-plated steel Type 289H, 2 NPT body, Carbon steel	1B633638992 1E564937022 13A9938X012 10B9241X012
14	Closing Cap Type 289H, 2 NPT body, Zinc Type 289L	1B541644012 T1007206992
15*	Gasket, Neoprene (CR) Types 289H and 289HH, 1 NPT body Type 289H, 2 NPT body Type 289L	13A9929X012 1P753306992 1E105606992
17	Lower Spring Seat, Zinc-plated steel Types 289H and 289HH, 1 NPT body Type 289H, 2 NPT body	1D666625072 1D779925062
18	Pitot Tube Types 289H and 289HH, 1 NPT body, Aluminum Type 289H, 2 NPT body Brass Stainless steel	1F826209012 1E701914012 1E701935032

\*Recommended Spare Parts

Delrin® is a mark owned by E.I. du Pont de Nemours and Co.

1. Assembly also includes an Aluminum pitot tube and brushing, a Zinc-plated steel spring seat and diaphragm head and a Neoprene (CR) seat pad.

2. Assembly also includes a Zinc diaphragm head.



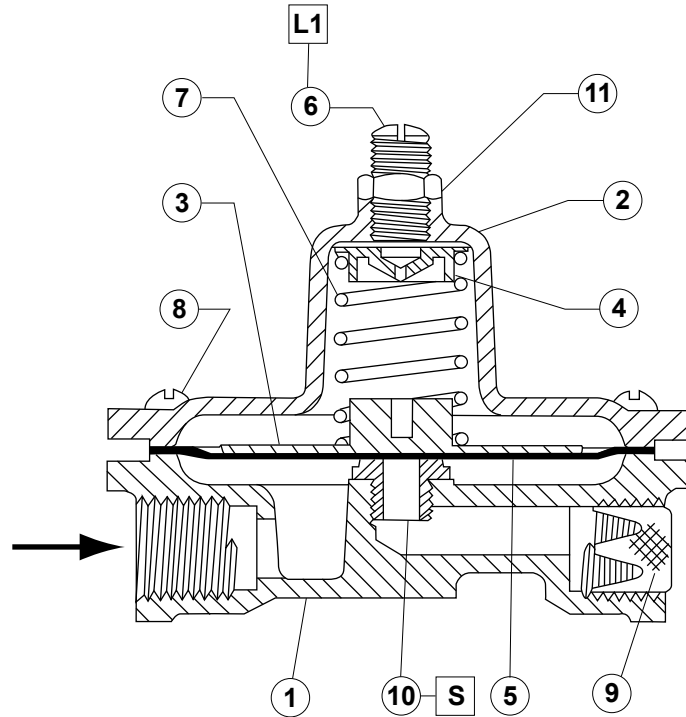

10A744-A

□ APPLY LUBRICANTS (L) / SEALANT (S)<sup>(1)</sup>:  
 L1 = ANTI-SEIZE COMPOUND  
 S = THREAD SEALANT

1. Lubricants and sealant must be selected such that they meet the temperature requirements.

**Figure 6. Type 289A Relief Valve**

Key	Description	Part Number	Key	Description	Part Number
19*	Gasket, Composition Types 289H and 289HH, 1 NPT body (1 required) Type 289H, 2 NPT body (3 required)	1F826804022 1D779804022	26	Lower Diaphragm Head, Zinc-plated steel Type 289H, 2 NPT body	1E703125072
20*	O-ring Type 289H, 1 NPT body Nitrile (NBR) Fluorocarbon (FKM) Type 289H, 2 NPT body Nitrile (NBR) Fluorocarbon (FKM) Type 289HH Nitrile (NBR) Fluorocarbon (FKM)	1F269206992 1F2692X0012 1P336106992 1V664606382 1F269206992 1F2692X0012	27	Washer, Aluminum Types 289H and 289HH, 1 NPT body Type 289H, 2 NPT body	1F826709012 1C680511032 T13718T0012
21	O-ring Holder, Aluminum Types 289H and 289HH, 1 NPT body	1F826409012	28	Pipe Plug, Types 289H and 289HH, Carbon steel	1H526928982
22	O-ring Washer Types 289H and 289HH, 1 NPT body, Aluminum Type 289H, 2 NPT body, Stainless steel	1F826509012 1E702136072	29	Machine Screw, Carbon-plated steel (not shown) Types 289H and 289HH, 1 NPT body (2 required) Type 289H, 2 NPT body (4 required)	1F386528992
23	Spacer Types 289H and 289HH, 1 NPT body, Stainless steel Type 289H, 2 NPT body Brass Stainless steel	1F826335242 1E702214172 1E702235162	30*	O-ring, Types 289H and 289HH, 1 NPT body (2 required) Nitrile (NBR) Fluorocarbon (FKM)	1D687506992 1N430406382
24	Hex Nut, Plated steel Types 289H and 289HH, 1 NPT body Type 289H, 2 NPT body	1A499724122 1B228228982	31	Stem Guide Assembly Types 289H and 289HH, 1 NPT body Zinc/Brass Zinc/303 Stainless steel Type 289H, 2 NPT body Cast iron/Brass Cast iron/303 Stainless steel	1F8272000A2 1F8272X0012 1E7028000A2 1E7028X00A2
			32	Lifting Lever (not shown), Steel Type 289H, 2 NPT body	0R061725092
			34*	Diaphragm Protector (not shown), Polytetrafluoroethylene (PTFE) Types 289A	10A5116X012
			38*	Gasket, Type 289H, 2 NPT body, Neoprene (CR)	11B1993X012

\*Recommended Spare Parts

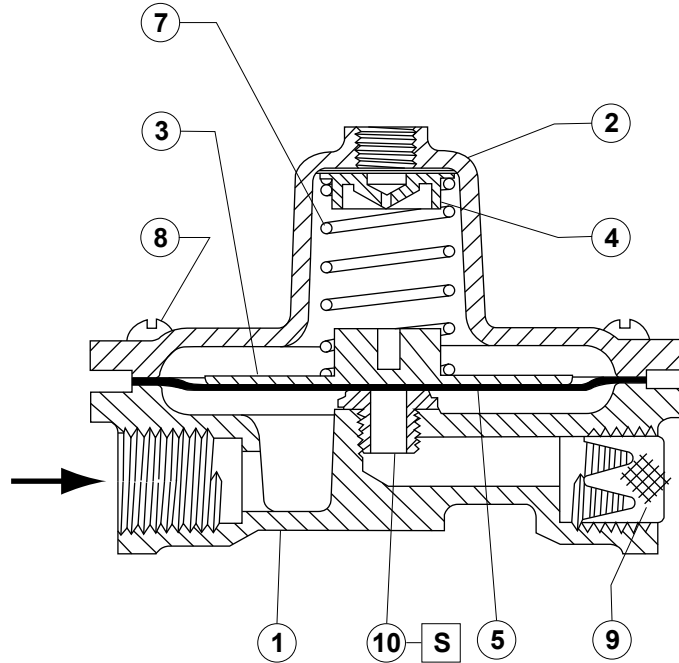

18A2816-A

APPLY SEALANT (S)<sup>(1)</sup>:  
S = THREAD SEALANT

1. Sealant must be selected such that it meets the temperature requirements.

**Figure 7. Type 289U Relief Valve**

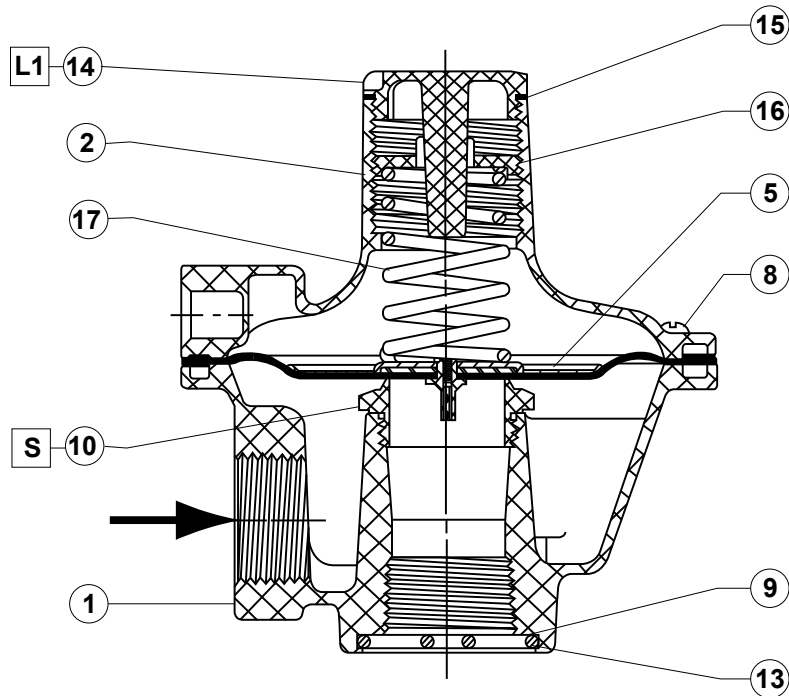

BL4063-E

APPLY LUBRICANTS (L) / SEALANT (S)<sup>(1)</sup>:  
L1 = ANTI-SEIZE COMPOUND  
S = THREAD SEALANT

1. Lubricants and sealant must be selected such that they meet the temperature requirements.

**Figure 8. Type 289L Relief Valve**

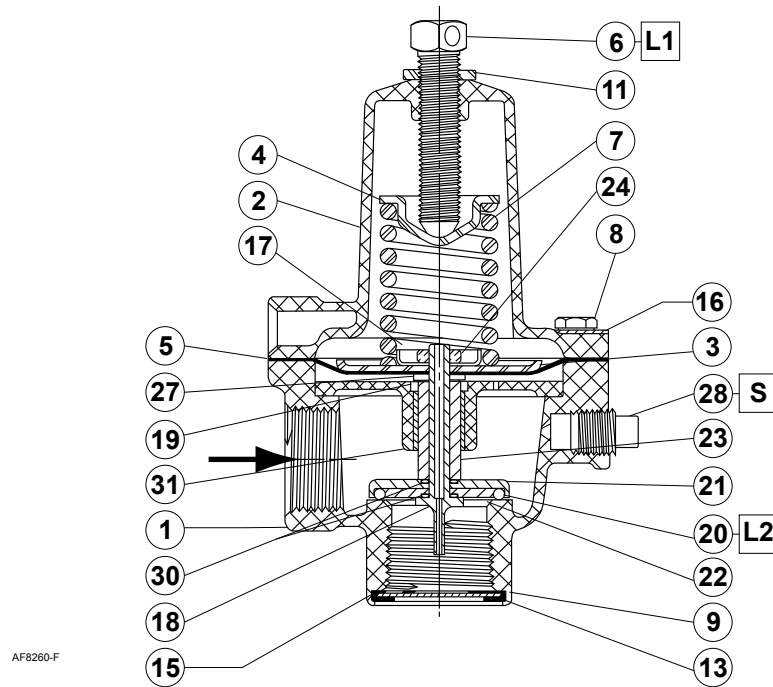
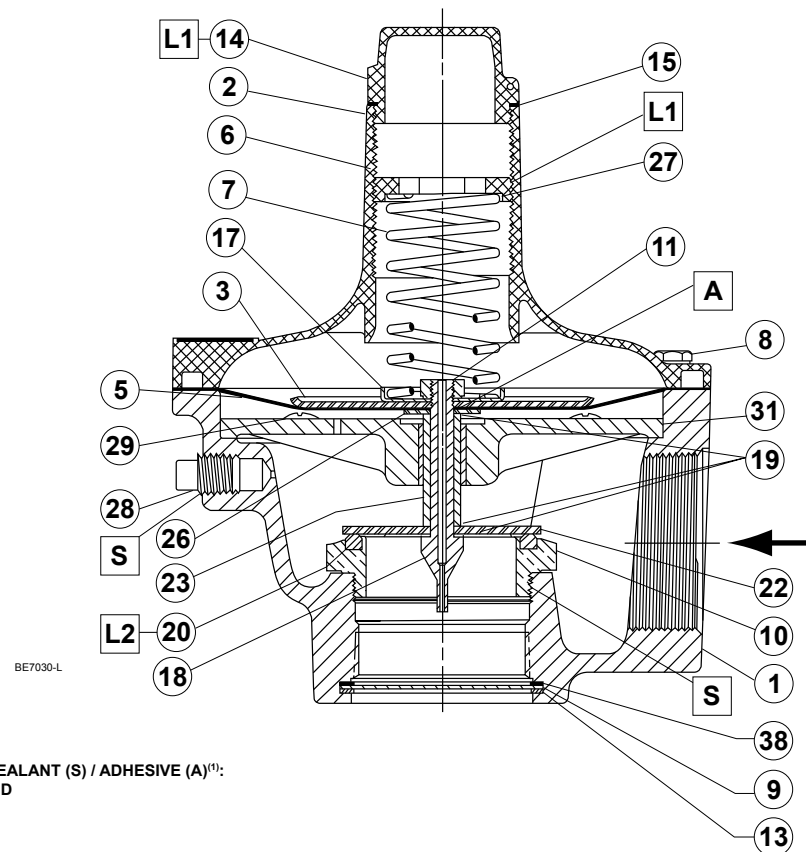

Figure 9. Types 289HH and 1 NPT 289H Relief Valves



- APPLY LUBRICANTS (L) / SEALANT (S) / ADHESIVE (A)<sup>(1)</sup>:
- L1 = ANTI-SEIZE COMPOUND
  - L2 = PTFE GREASE
  - S = THREAD SEALANT
  - A = ADHESIVE

1. Lubricants, sealant and adhesive must be selected such that they meet the temperature requirements.

Figure 10. 2 NPT Type 289H Relief Valve

✉ [Webadmin.Regulators@emerson.com](mailto:Webadmin.Regulators@emerson.com)

🔍 [Fisher.com](http://Fisher.com)

📘 [Facebook.com/EmersonAutomationSolutions](https://Facebook.com/EmersonAutomationSolutions)

🌐 [LinkedIn.com/company/emerson-automation-solutions](https://LinkedIn.com/company/emerson-automation-solutions)

🐦 [Twitter.com/emr\\_automation](https://Twitter.com/emr_automation)

## **Emerson Automation Solutions Regulator Technologies**

### **Americas**

McKinney, Texas 75070 USA  
T +1 800 558 5853  
+1 972 548 3574

### **Europe**

Bologna 40013, Italy  
T +39 051 419 0611

### **Asia Pacific**

Singapore 128461, Singapore  
T +65 6770 8337

### **Middle East and Africa**

Dubai, United Arab Emirates  
T +971 4 811 8100

D100280X012 © 2002, 2017 Emerson Process Management Regulator Technologies, Inc. All rights reserved. 03/17.

The Emerson logo is a trademark and service mark of Emerson Electric Co. All other marks are the property of their prospective owners. Fisher™ is a mark owned by Fisher Controls International LLC, a business of Emerson Automation Solutions.

The contents of this publication are presented for information purposes only, and while effort has been made to ensure their accuracy, they are not to be construed as warranties or guarantees, express or implied, regarding the products or services described herein or their use or applicability. All sales are governed by our terms and conditions, which are available on request. We reserve the right to modify or improve the designs or specifications of our products at any time without notice.

Emerson Process Management Regulator Technologies, Inc. does not assume responsibility for the selection, use or maintenance of any product. Responsibility for proper selection, use and maintenance of any Emerson Process Management Regulator Technologies, Inc. product remains solely with the purchaser.

