



MULTI FITTINGS

LAYING LENGTH

ISSUE DATE: OCT 30/17
SUPERCEDES: MAR 11/05

45° ELBOW (GxG) (1/8 BEND)

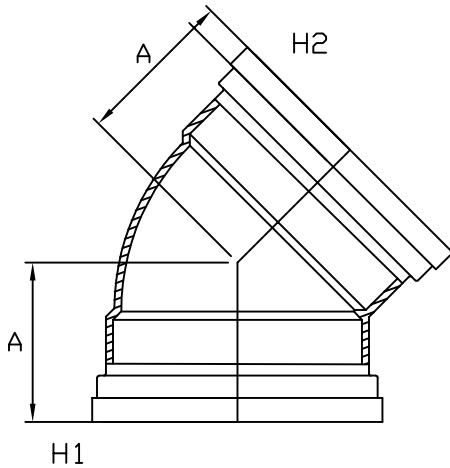

INJECTION MOLDED FITTING (<M>)

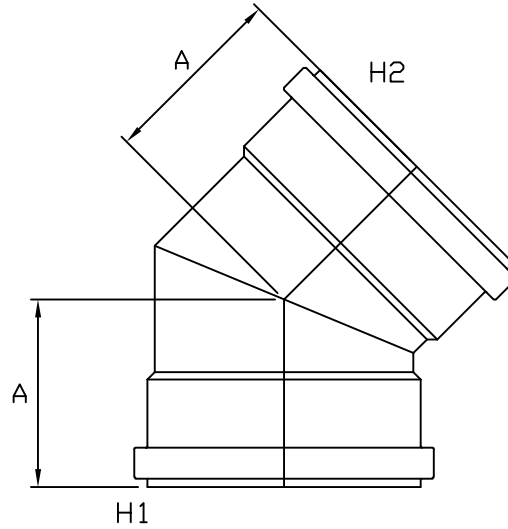

FABRICATED FITTING (<F>)

	SIZE H1xH2	PART NUMBER	A REF
<>M =	4x4	063504	3. 625
% M =	4x4 EXT	063409	3. 500
M =	6x6	063506	4. 375
% M =	6x6 EXT	063420	5. 625
M =	8x8	063507	5. 375
M =	10x10	063508	6. 250
M =	12x12	063509	7. 250
M =	15x15	143515	8. 250
F @	18x18	043971	21. 500
F @	21x21	043957	24. 000
F @	24x24	043953	24. 000
F @	27x27	043516	34. 000

Note: = Refer to Page G4 for Hub Detail, Type A
 @ Refer to Page G5 for Hub Detail, Fabricated
 <> Deep Hub - Page G4 - Type A
 % Long Hub - Page G4 - Type A