

tekmar® Submittal

tekmarNet® 4 Gateway 482



Accessories

C 482

01/11

Replaces: New

Job _____ Designer _____ Contact _____

The tekmarNet® 4 Gateway 482 provides RS 232 serial communication between tekmarNet® thermostats and third party home automation systems. The third party automation system is able to monitor and adjust any of the thermostat's heating, cooling, and ventilation fan settings. Through the use of third party device drivers written for this product, tekmarNet® systems are fully integrated into home automation systems.

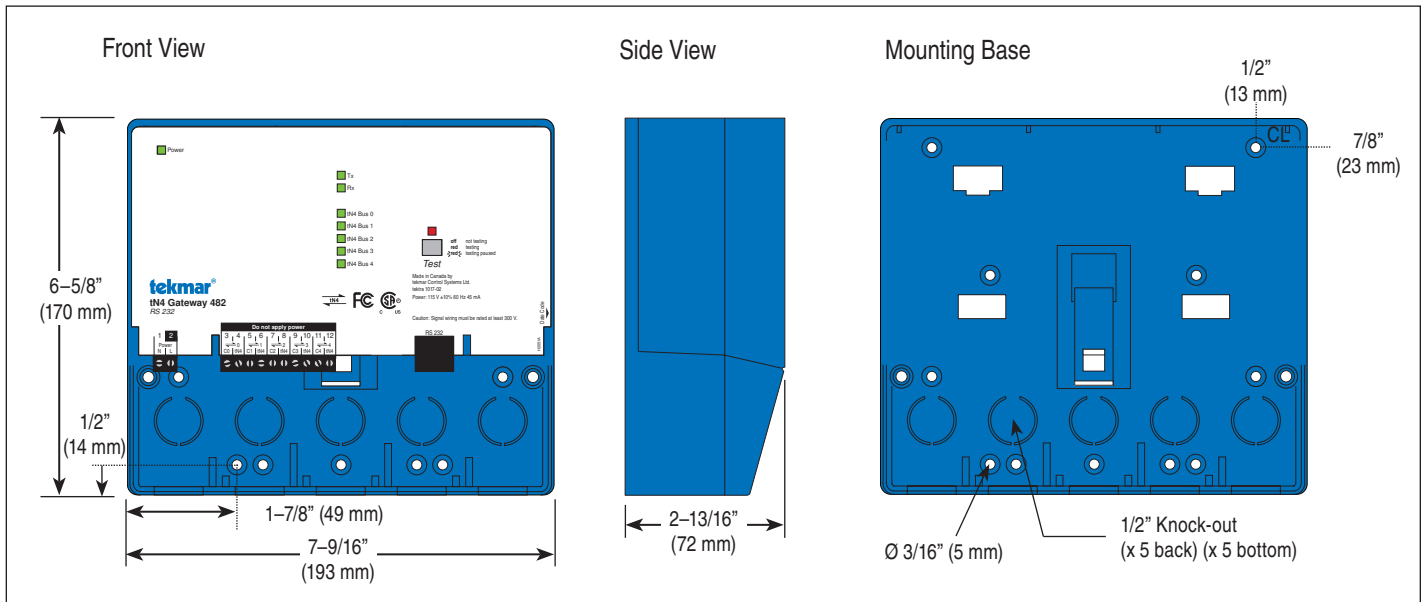

Specifications

| tN4 Gateway 482 RS 232 | |
|------------------------|---|
| Literature | D482 |
| Control | Microprocessor PID control. This is not a safety (limit) control |
| Packaged weight | 3.6 lb (1600 g) |
| Dimensions | 6-5/8" H x 7-9/16" W x 2-13/16" D (170 x 193 x 72 mm) |
| Enclosure | Enclosure A, blue PVC plastic, NEMA type 1 |
| Approvals | CSA C US, meets ICES & FCC regulations for EMI / RFI |
| Ambient conditions | Indoor use only, 32 to 122°F (0 to 50°C), 9842 feet (3000 m) maximum altitude |
| Power supply | 115 V ± 10%, 60 Hz, 45 mA |
| Warranty | Limited 3 year (see D482 for full warranty) |

Features

- tekmarNet® 4 and tekmarNet® 2 compatible
- CSA C US approved for US and Canada
- Drivers available for leading home automation systems

SPECIAL REQUIREMENTS

Requires a device driver installed on the third party home automation hardware to allow communication. Many third parties have this driver available. Please consult www.tekmarcontrols.com for compatible systems.

Sample Application Drawing

Below is a sample application drawing for this product. This application may include other tekmar products that are required for installation. More sample applications can be found at www.tekmarcontrols.com.

Sample Mechanical diagram

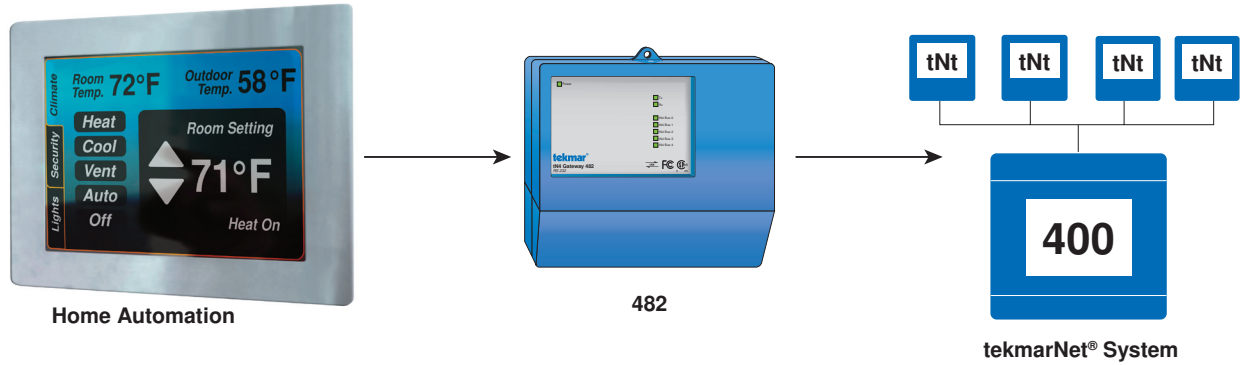

Sample Electrical diagram

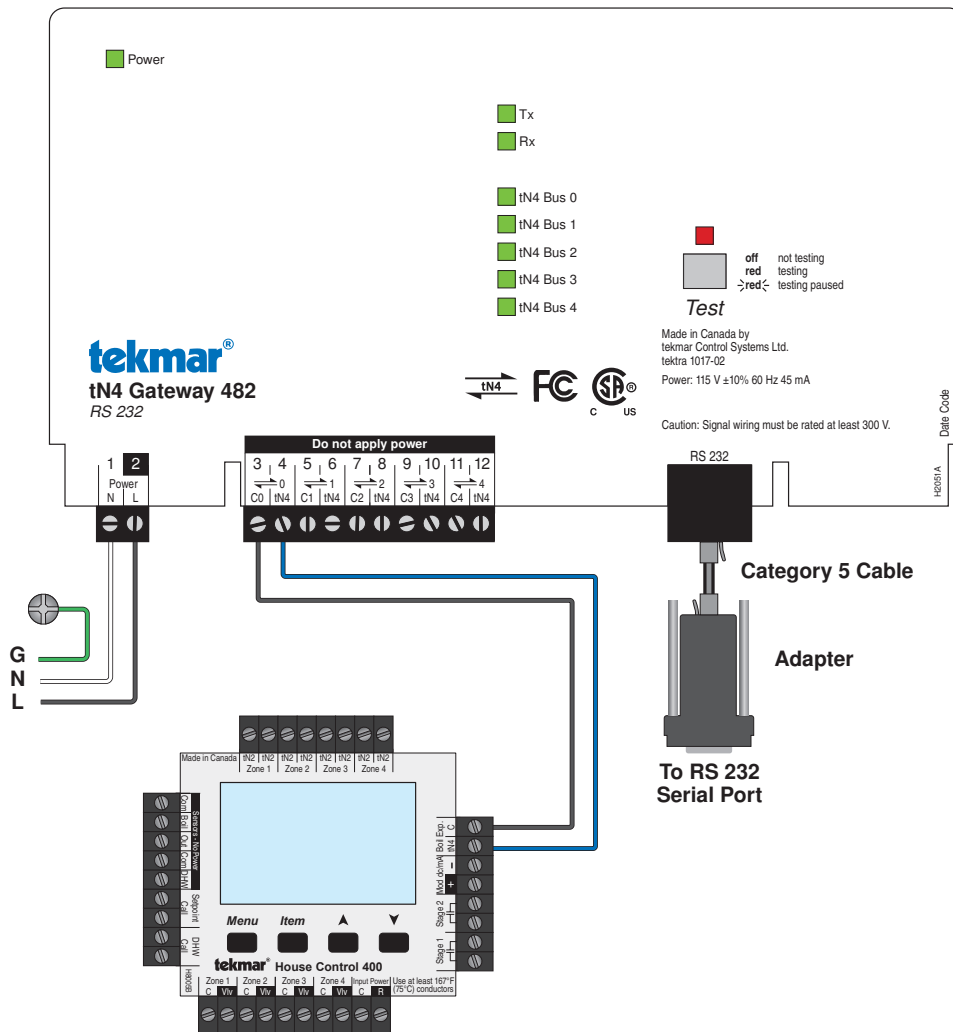

tekmar Control Systems Ltd., Canada, tekmar Control Systems, Inc., U.S.A. **Head Office: 5100 Silver Star Road, Vernon, B.C. Canada V1B 3K4, 250-545-7749, Fax. 250-545-0650 Web Site: www.tekmarcontrols.com**