

# SUBMITTAL INFORMATION

## Angle Check Valve - (HA91-xxx-NL style)

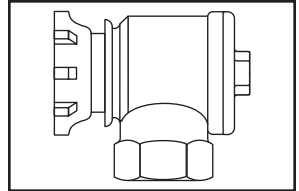

### METER YOKE NOSE INLET BY FEMALE IRON PIPE THREAD OUTLET

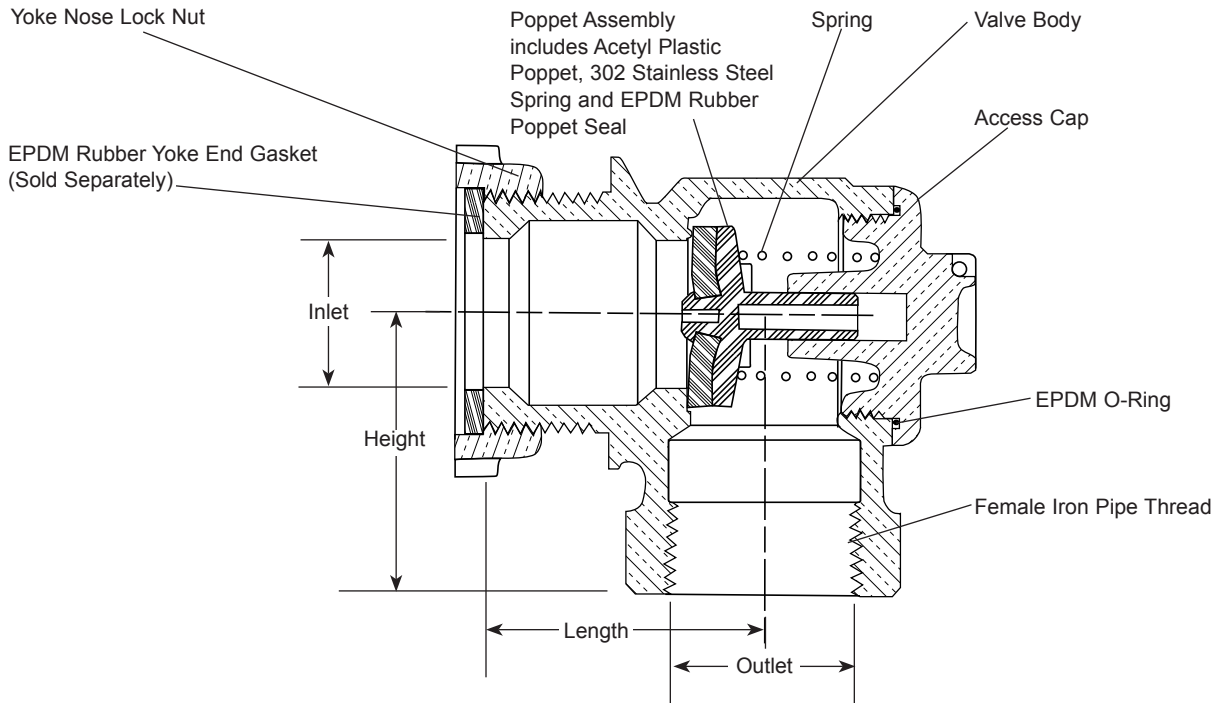

VALVE SIZE	METER SIZE	OUTLET SIZE	LENGTH	HEIGHT	APPROX. WT. LBS	CATALOG NUMBER	✓ SUBMITTED ITEM(S)
3/4"	5/8"	3/4"	1-9/16"	1-11/16"	1.3	HA91-313-NL	
3/4"	5/8"x3/4" & 3/4"	3/4"	1-9/16"	1-11/16"	1.2	HA91-323-NL	
1"	1"	1"	1-15/16"	1-15/16"	1.6	HA91-444-NL	

Drain/Test Valve available - add "D" to catalog number

### FEATURES

- All brass that comes in contact with potable water conforms to AWWA Standard C800 (UNS C89833)
- The product has the letters "NL" cast into the body for proper identification
- UL Classified to ANSI/NSF Standard 61 and Standard 61 Annex G (NSF/ANSI 372)
- Brass components that do not come in contact with potable water conform to AWWA Standard C800 (ASTM B-62 and ASTM B584, UNS C83600-85-5-5-5)
- In-Line Accessible for quick inspection and replacement of internal working parts without removing the valve from the service line. Replacement kits are available.
- 175 PSI maximum working water pressure
- 180 degree Fahrenheit maximum constant temperature
- EPDM Rubber Yoke Nose gasket sold separately: GT-112 (5/8"), GT-118 (3/4") and GT-123 (1")

The Ford Meter Box Company considers the information in this submittal form to be correct at the time of publication. Item and option availability, including specifications, are subject to change without notice. Please verify that your product information is current.



#### The Ford Meter Box Company, Inc.

P.O. Box 443, Wabash, Indiana U.S.A. 46992-0443

Phone: 260-563-3171 / Fax: 800-826-3487

Overseas Fax: 260-563-0167

<http://www.fordmeterbox.com>

02/27/13

Submitted By: