

SUBMITTAL INFORMATION

Straight Dual Cartridge Check Valve - (HHCI33-xxx-NL style)

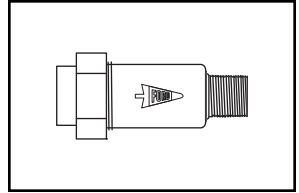

FEMALE METER THREAD UNION INLET BY MALE METER THREAD OUTLET

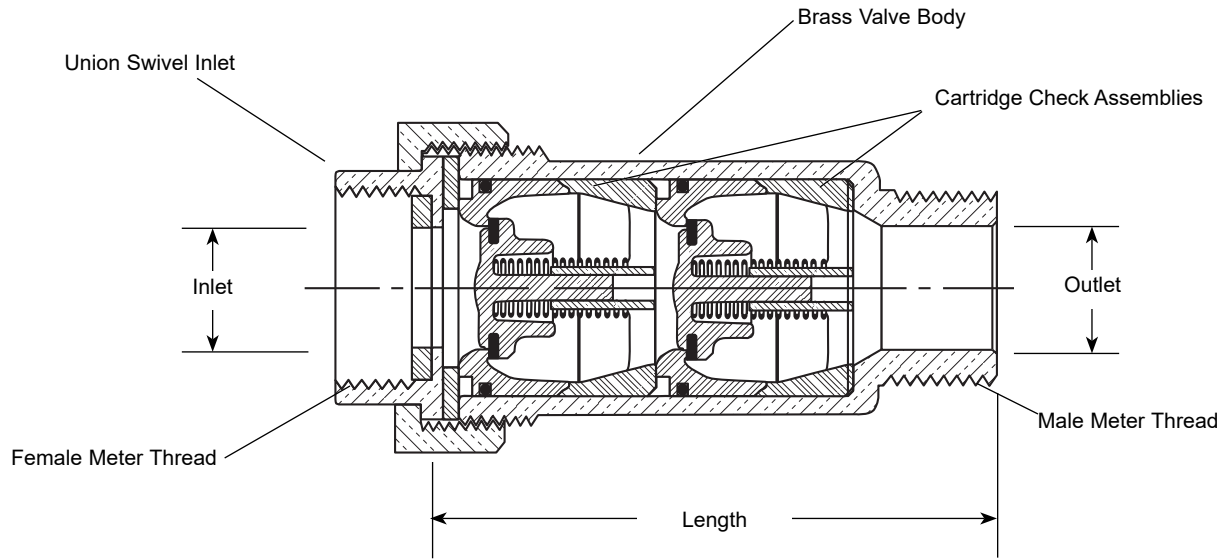

VALVE SIZE	METER INLET SIZE	METER OUTLET SIZE	LENGTH	APPROX. WT. LBS	PART NUMBER	✓ SUBMITTED ITEM(S)
3/4"	5/8"	5/8"	3-25/32"	1.5	HHCI33-311-NL	
3/4"	5/8" x 3/4" & 3/4"	5/8" x 3/4" & 3/4"	3-3/4"	1.5	HHCI33-322-NL	

FEATURES

- All brass that comes in contact with potable water conforms to AWWA Standard C800 (ASTM B584, UNS C89833)
- The product has the letters "NL" cast into the main body for lead-free identification
- Certified to NSF/ANSI Standard 61 and NSF/ANSI Standard 372 where applicable
- Brass components that do not come in contact with potable water conform to AWWA Standard C800 (ASTM B62 and ASTM B584, UNS C83600, 85-5-5-5)
- ASSE 1024 approved
- Accessible through the union swivel inlet for inspection and replacement of internal working parts. Replacement kits are available.
- 175 PSI maximum working water pressure
- 180 degree Fahrenheit maximum constant temperature
- Conforms to AWWA C700 for meter threads

The Ford Meter Box Company considers the information in this submittal form to be correct at the time of publication. Item and option availability, including specifications, are subject to change without notice. Please verify that your product information is current.



The Ford Meter Box Company, Inc.

P.O. Box 443, Wabash, Indiana U.S.A. 46992-0443

Phone: 260-563-3171 / Fax: 800-826-3487

Overseas Fax: 260-563-0167

www.fordmeterbox.com

09/23/16

Submitted By: