

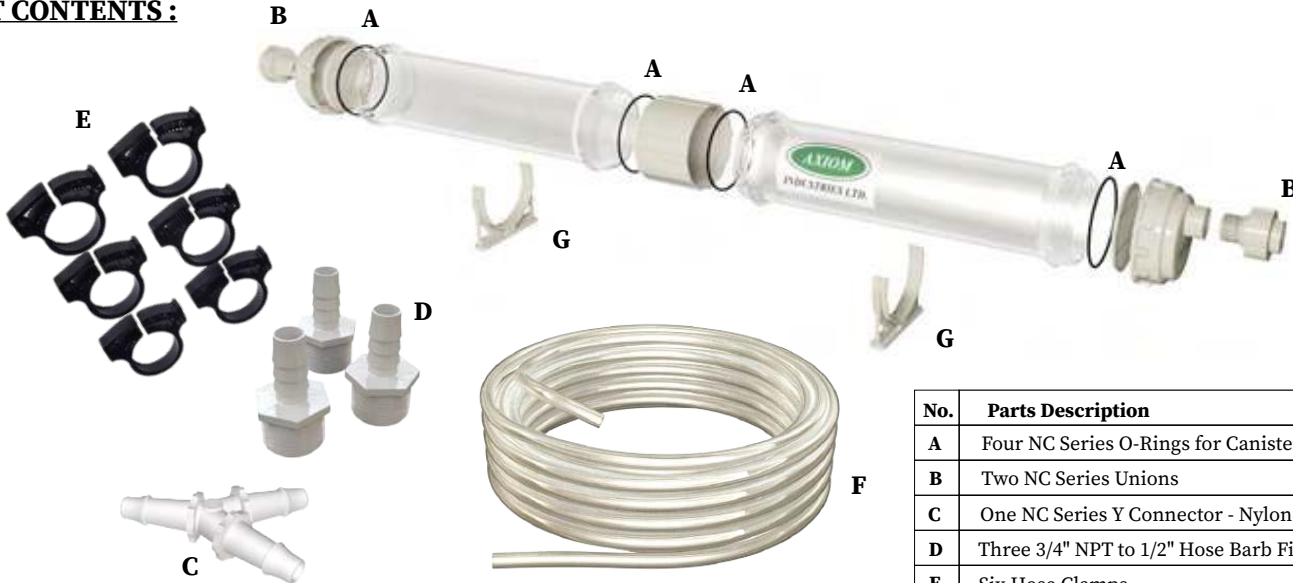

NC-2 Condensate Neutralizer Technical Information

KIT CONTENTS :



No.	Parts Description
A	Four NC Series O-Rings for Canister
B	Two NC Series Unions
C	One NC Series Y Connector - Nylon
D	Three 3/4" NPT to 1/2" Hose Barb Fittings
E	Six Hose Clamps
F	10ft of 1/2" Vinyl Tubing
G	Two Base/Wall Mounting Clamps

DIMENSIONS :

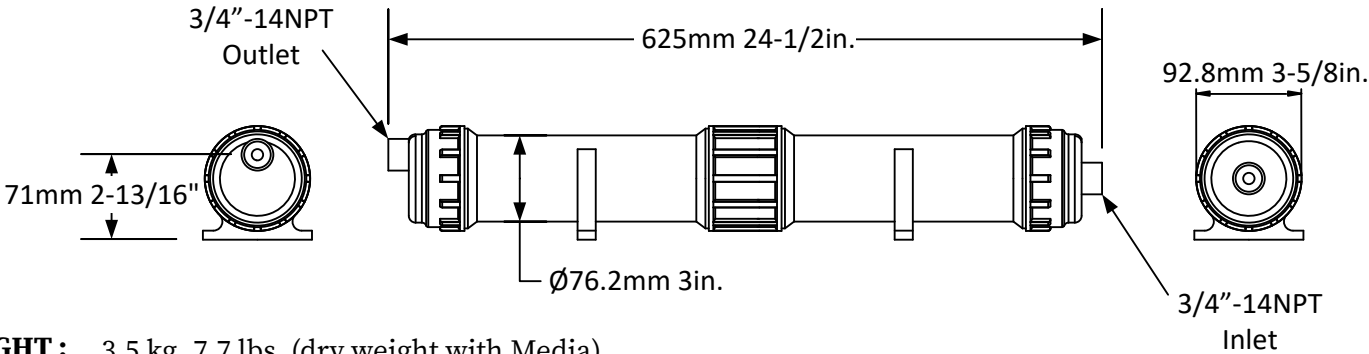

WEIGHT : 3.5 kg, 7.7 lbs. (dry weight with Media)

SPECIFICATION :

The condensate neutralization capsule shall be AXIOM INDUSTRIES LTD. model NC-2. System shall include 2 litre (0.53 U.S. gallon) transparent capsule made from Corrosion resistant materials with two 3" fill/access openings, 3" inlet and outlet screen, 3/4"-14NPT threaded inlet, 3/4"-14NPT threaded outlet, two 3/4" MNPT x 3/4" FNPT unions, three 3/4" NPT to 1/2" hose barb fittings, 1/2" barbed Y fitting, six hose clamps, 10 ft of 1/2" ID vinyl tubing, two base/wall mounting clamps.

OPTIONAL ACCESSORIES :

- 2 x NM-1** -- Replacement LipHter+ neutralization media (NM-1 x 2 for exact Refill)
- NM-1BULK** -- Replacement LipHter+ neutralization media (Up to 7 Refills)



LIMITED WARRANTY :

The "NC-2" is warranted against defects in materials and workmanship for one year.

Project _____
 Consultant _____
 Unit Tag _____

Location _____
 Contractor _____
 Sales Agent _____