

# SUBMITTAL DATA SHEET

## NL Ball Style Meter Stop – 74642BY-22

-22 CTS Compression x Yoke Star Nut

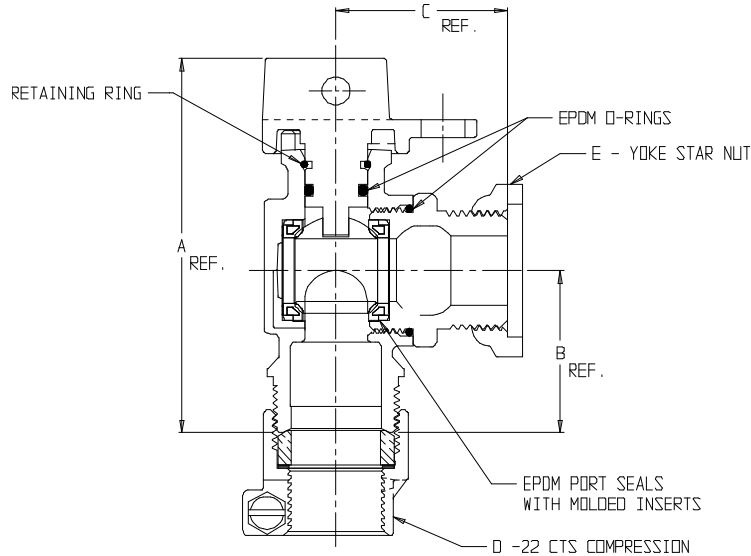

MODEL	SIZE	A	B	C	D	E
74642BY-22	3/4 X 5/8 X 01	3.74	1.62	1.71	3/4	5/8
74642BY-22	1 X 5/8 X 01	3.72	1.60	1.71	1	5/8
74642BY-22	3/4 X 5/8 X 02	3.74	1.62	1.71	3/4	5/8 X 3/4 OR 3/4
74642BY-22	1 X 5/8 X 02	3.72	1.60	1.71	1	5/8 X 3/4 OR 3/4
74642BY-22	1 X 3/4 X 04	4.63	2.21	2.13	1	1

### SUBMITTAL INFORMATION

- Manufactured in compliance with ANSI/AWWA C800 (latest revision)
- Brass components in contact with potable water conform to ASTM B584, UNS C89833 (latest revision) and identified with "NL"
- Certified to NSF/ANSI 61 and NSF/ANSI 372
- Brass components not in contact with potable water conform to ASTM B62 and ASTM B584, UNS C83600 -85-5-5-5 (latest revision)
- PTFE coated brass ball
- Rated for 300 PSIG water pressure
- Blow out proof EPDM port seals
- End piece joint sealed with an EPDM o-ring and thread locker
- Insert stiffeners required on all flexible plastic connections



**A.Y. McDonald Mfg. Co.**  
P.O. Box 508  
Dubuque, IA 52004-508

**Toll Free: 1-800-292-2737**  
**Fax: 1-800-832-9296**  
**Hours: 7:00 a.m. – 5:00 p.m., CST**

sales@aymcdonald.com  
[www.aymcdonald.com](http://www.aymcdonald.com)

A.Y. McDonald considers the information on this assembly drawing correct when published. Item and option availability, including specifications, are subject to change without notice.

**Submitted by:**