

INSTALLATION SETUP AND OPERATING INSTRUCTIONS
THERMOSTATIC WATER MIXING VALVE SYSTEMS
TYPE TM-600, TM-600-LF, TM-650, TM-800, TM-800-LF, TM-850, TM-850-LF
TM-5100, TM-5100-LF, TM-5125, TM-5125-LF

IMPORTANT! Provide valve serial number, (stamped on valve cover) when ordering parts!!

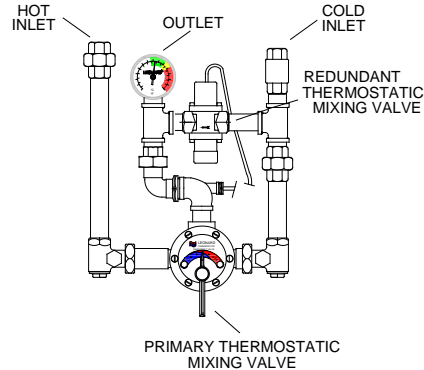
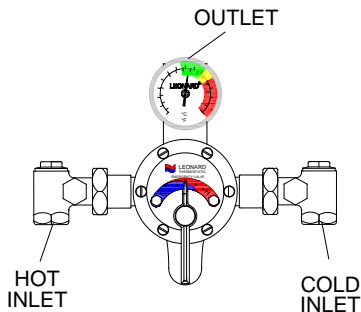

TM-600, TM-600-LF, TM-800, TM-800-LF, TM-5100, TM-5100-LF

TM-650, TM-850, TM-850-LF
TM-5125, TM-5125-LF

INSTALLATION

Valve should be installed at a location where it can easily be cleaned, adjusted or repaired.

Union angle strainer checkstops furnished must be installed on both supply lines **as shown above**.

The inlets are clearly marked on the valve body casting. Connect the hot water into the inlet marked "HOT" and cold water into the inlet marked "COLD." These are **NOT** to be confused with the "C-H" markings on the front cover.

Use solder or pipe cement sparingly. Supply pipes should be flushed before the valve is connected. Flush outlet pipe and valve as soon as it is connected.

Maximum Operating Pressure 125PSI (860 KPA)
for Hot and Cold Water.

NOTE: It may be necessary to recirculate the tempered water to the face/eyewash/drench shower should the piping be exposed to excessive hot or cold conditions. Consult factory for proper piping.



CAUTION



IMPORTANT! These systems are designed to provide mixed water from 60 to 90°F (15 to 32°C) for emergency shower applications only. Call Leonard for systems designed to operate at temperatures outside of this range.

REMEMBER! THIS IS A CONTROL SYSTEM WHICH MUST BE CLEANED AND MAINTAINED ON A REGULAR BASIS (SEE MAINTENANCE GUIDE AND RECORD MGR-1000).

1360 Elmwood Avenue, Cranston, RI 02910 USA
Phone: 401.461.1200 Fax: 401.941.5310
Email: info@leonardvalve.com
Web Site: <http://www.leonardvalve.com>

ADJUSTMENT AND SERVICE

Leonard Type TM Thermostatic Water Mixing Valves are simple in design and may be easily cleaned, adjusted and repaired. If the installation is accessible, servicing may be completed without disconnecting the valve.

NOTE: Thermostatic Water Mixing Valves are REGULATING mechanisms, which must be regularly maintained to provide best performance. Frequency of cleaning depends on quality of local water conditions and usage. (See Maintenance Guide and Record MGR-1000 and ANSI 358.1).

TO RESET ADJUSTABLE HIGH TEMPERATURE LIMIT STOP:

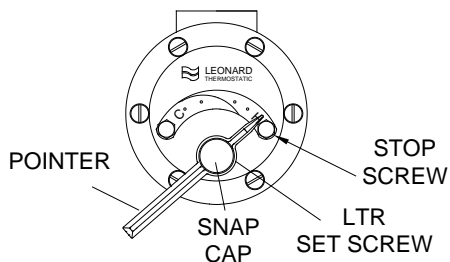

1. Loosen LTR set screw.
2. Remove SNAP CAP, SCREW & WASHER. Remove POINTER.
3. Temporarily place POINTER on the spline rod, turn HANDLE to the left, allow cold water to flow. Slowly adjust handle to the right to required maximum temperature. (Temperatures above 90°F are not recommended on Emergency equipment, consult medical advisor for correct temperature settings).
4. Replace POINTER on the spline rod so that its RIGHT edge is resting against the STOP SCREW located on the RIGHT SIDE OF THE COVER.
5. The new maximum temperature has now been set. Test this temperature by holding a thermometer under the flow of water to be certain it is as desired.



WARNING



WARNING! This Thermostatic Mixing Valve has an adjustable high temperature limit stop which must be checked. If temperature is too high, the installer **MUST RESET** stop immediately. Always check the temperature of the mixed water when the lever handle is turned to full **HOT**. If the Emergency Drench equipment is a combination type, the water temperature must be checked at each outlet (FACE/EYEWASH /SHOWER) location independently. Excessively hot water is **DANGEROUS AND MAY CAUSE SCALDING!**

Consult medical advisor for correct temperature setting.

The high temperature limit stop is factory set at approximately 90°F (32.2°C) with an incoming hot water supply temperature of 150°F (65°C). If the incoming hot water on the job is higher than 150°F, the valve when turned to full hot will deliver water in excess of 90°F and the high temperature limit stop **MUST BE RESET BY THE INSTALLER.**

TROUBLESHOOTING INSTRUCTIONS

		TM-600, 650, 800, 850	TM-5100, 5125
PACKINGS & GASKETS	Leak at pointer rod. Leak between valve cover and base	REPAIR KIT 1/50M	REPAIR KIT 1/125M
PORT SLEEVE ASSEMBLY	Valve delivers either all hot or all cold water, or will not mix consistently.	REPAIR KIT TGM-1/50M or REPAIR KIT R/50M	REPAIR KIT TGM-1/125M or REPAIR KIT R/125M
THERMOSTAT GROUP	After cleaning or replacing port sleeve assembly, valve will not hold temperature.	REPAIR KIT TGM-2/50 or REPAIR KIT R/50M	REPAIR KIT TGM-2/125 or REPAIR KIT R/125M
CHECKSTOPS	Hot water bypass into cold line. Supplies cannot be shut off completely. Leak at checkstop bonnet.	REPAIR KIT 2/50M	REPAIR KIT 2/50M

SEE PAGE 5 FOR COMPLETE PARTS BREAKDOWN, AND PARTS KITS

If installed on a circulated hot water system, make certain the valve is piped according to Leonard Required Methods of Piping (see page 3).

REMEMBER! THIS IS A CONTROL DEVICE WHICH MUST BE CLEANED AND MAINTAINED ON A REGULAR BASIS. (SEE MAINTENANCE GUIDE AND RECORD, MGR-1000).

REQUIRED METHOD OF PIPING TM VALVES

METHOD #1

Required when hot water is to be circulated to a thermostatic mixing valve, which is a substantial distance from the hot water source. Recommended Hot Water Inlet Temperature 140°F (60°C).

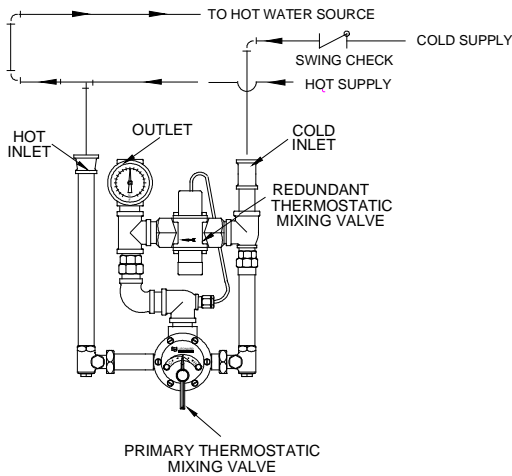

TM-650, 850, 5125

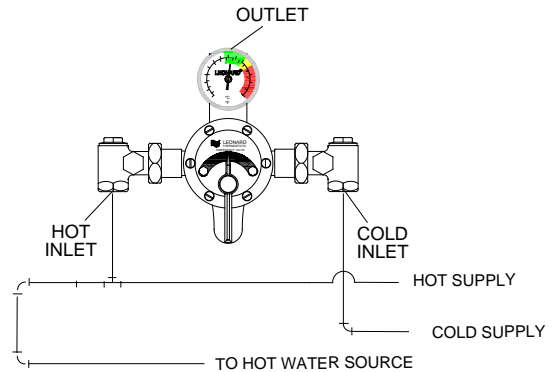

TM-600, 800, 5100

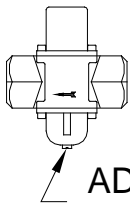

ADJUSTMENT SCREW

The TM-650, 850 & 5125 Redundant Thermostatic Mixing Valve has been factory set at 90°F (32°C). This set point can be field adjusted with a 3/8" wrench (see diagram). "Clockwise" direction will increase temperature. Maximum set point is 100°F (38°C). Consult medical advisor for correct temperature setting. As a secondary level of protection, in the event of redundant valve failure, installing contractor may wish to prevent cold water contamination by installing a swing check valve on the cold water supply to the valve (only needed on TM-650, 850, and 5125).

This unit must be cycled each time the emergency equipment is checked. (See ANSI Z358.1, Maintenance and Training section).

<p>Cycle redundant thermostatic valve by loosening the pointer set screw and set the primary thermostatic mixing valve to full hot. (TM-650, TM-850, TM-5125 only).</p> <p>Open drench or combination emergency shower and allow temperature to reach the set point. Temperature will drop when secondary valve opens to cool output.</p> <p>Turn primary thermostatic valve to full cold and wait ten seconds, this will close secondary valve.</p>	<p>Turn primary thermostatic valve to full hot and wait for ten seconds.</p> <p>Check to be sure outlet temperature does not climb above 90°F (32°C) or above recommended maximum temperature set by medical advisor.</p> <p>Turn primary thermostatic mixing valve to full cold and wait ten seconds.</p> <p>Set primary thermostatic mixing valve to the desired temperature and close drench or combination emergency shower.</p>
--	--

INSTRUCTIONS FOR DISMANTLING VALVE

Shut off hot and cold supplies to valve.

Loosen POINTER SET SCREW, Remove SNAP CAP, SCREW and WASHER, POINTER and FRICTION SPRING. (FIGURE #1).

Remove the 6 COVER SCREWS, then take off cover to which the Thermostat and Gears are attached.

WHEN RE-ASSEMBLING VALVE, insert new Flange Packing in base; replace COVER, tightening COVER SCREWS in rotation; put FRICTION SPRING in place; then replace POINTER and POINTER ROD SCREW, WASHER and CAP.

After installing new parts, it will probably be necessary to reset Pointer to obtain correct temperature range from Cold to Hot. See page 2 instructions "TO RESET ADJUSTABLE HIGH TEMPERATURE LIMIT STOP."

TO CLEAN PORT SLEEVE ASSEMBLY

Failure to properly blend the water may be caused by a sticking condition in the PORT SLEEVE ASSEMBLY. The THIMBLE should slide freely on the PORT SLEEVE.

If a deposit of lime or sediment prevents free movement, use a nail set or other tapered tool to unscrew the CHECK NUT as far as it will go, then screw the PORT SLEEVE NUT into the base. This will release the PORT SLEEVE and THIMBLE so they can be lifted out, (Figure #2).

Clean with a NON-CORROSIVE CLEANING AGENT AND SOFT CLOTH - DO NOT USE ABRASIVES - then wash parts thoroughly, wipe with a dry cloth and re-assemble. The PORT SLEEVE should be assembled with the elongated holes to the right (COLD SIDE). Tighten PORT SLEEVE NUT against end of PORT SLEEVE but be careful not to over tighten, this may deform port sleeve. Tighten CHECK NUT.

When replacing front be sure DRIVING BALL is inserted in Ball Socket as shown in Figure #1.

TO REPLACE POINTER ROD WITH GEAR

Loosen POINTER SET SCREW, remove POINTER ROD SNAP CAP, SCREW, WASHER, POINTER, and FRICTION SPRING. (FIGURE #1)

Remove COVER with parts attached, from the front of valve.

Remove COIL SLEEVE STUD and take off THERMOSTAT GROUP.

Replace POINTER ROD with GEAR and re-assemble.

TO REPLACE (OR CLEAN) THERMOSTAT GROUP

Follow instruction for replacing POINTER ROD with GEAR above. If a deposit has collected on the Thermostatic Coil, clean it off with a brush in a non-corrosive grit-free cleaning solution.

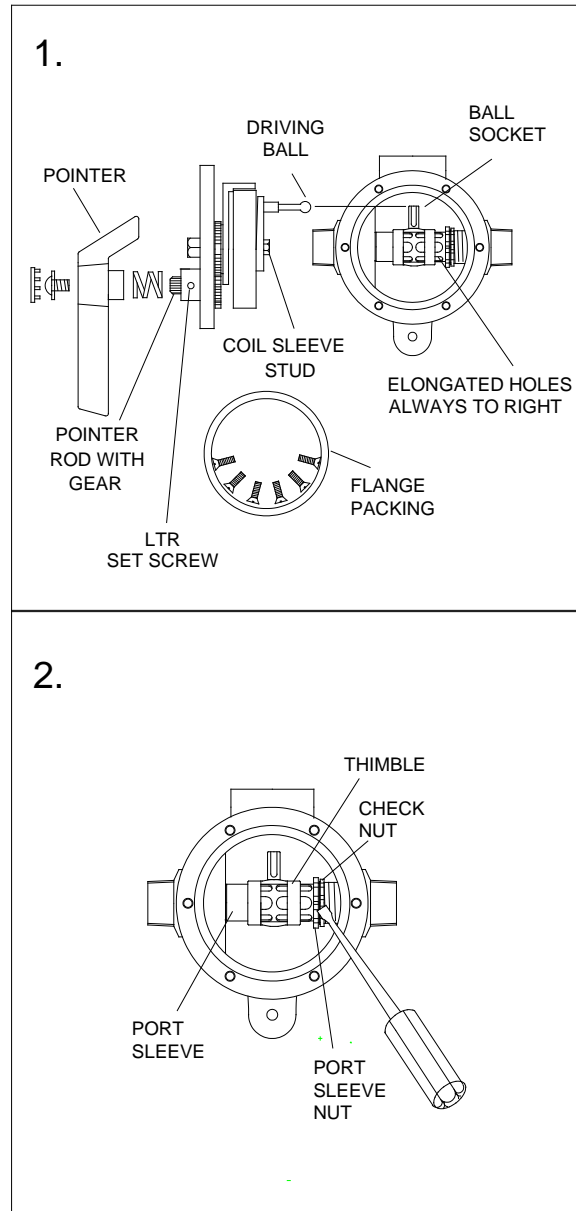

REMEMBER! THIS IS A CONTROL DEVICE WHICH MUST BE CLEANED AND MAINTAINED ON A REGULAR BASIS. (SEE MAINTENANCE GUIDE AND RECORD, MGR-1000)

TM-600, 650, 800, 850 VALVE PARTS

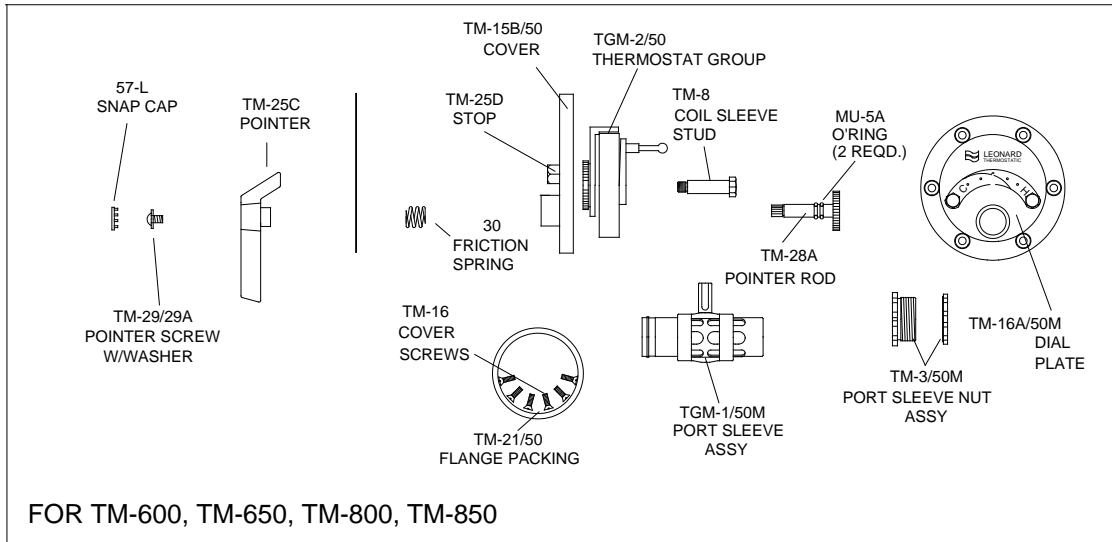

CHECKSTOP PARTS

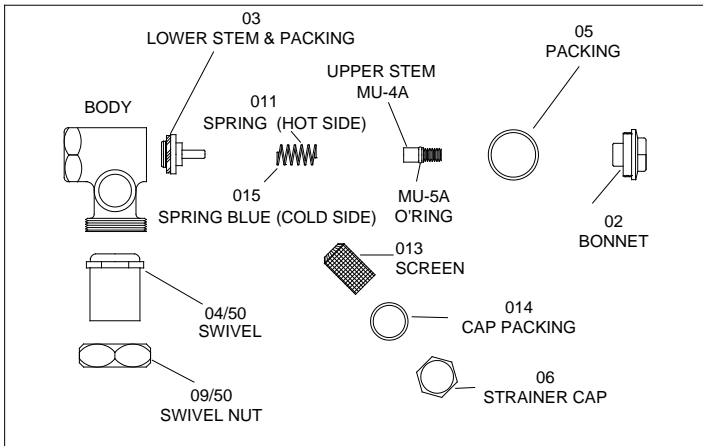

REPAIR KITS

FOR TM-600, 650, TM-800 & 850

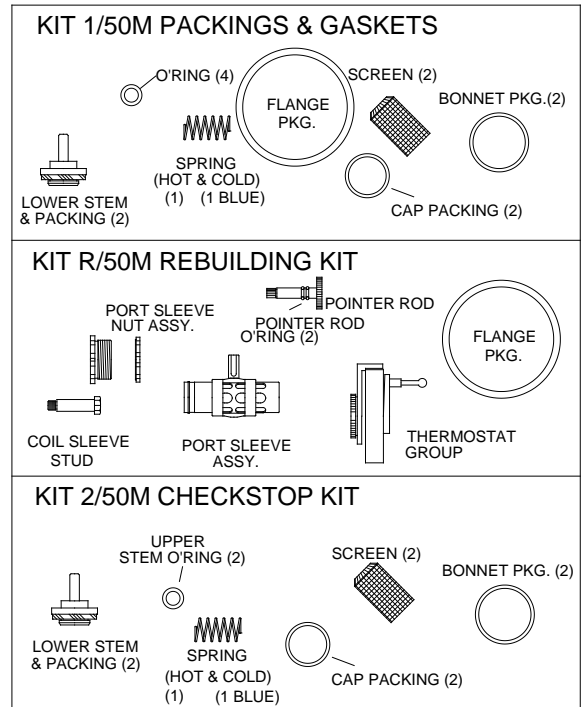

LOCK-TYPE POINTER (SUFFIX LTR)

All TM-600, 650, 800 & 850, valves are furnished with lockable pointers. See part noted.

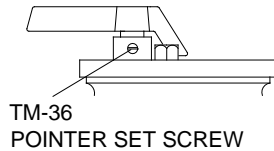

REMEMBER! THIS IS A CONTROL DEVICE WHICH MUST BE CLEANED AND MAINTAINED ON A REGULAR BASIS (SEE MAINTENANCE GUIDE AND RECORD, MGR-1000)

NOTE: AFTER INSTALLING NEW PARTS IT WILL BE NECESSARY TO RESET THE ADJUSTABLE HIGH TEMPERATURE LIMIT STOP (SEE PAGE 2).

TM-5100, 5125 VALVE PARTS

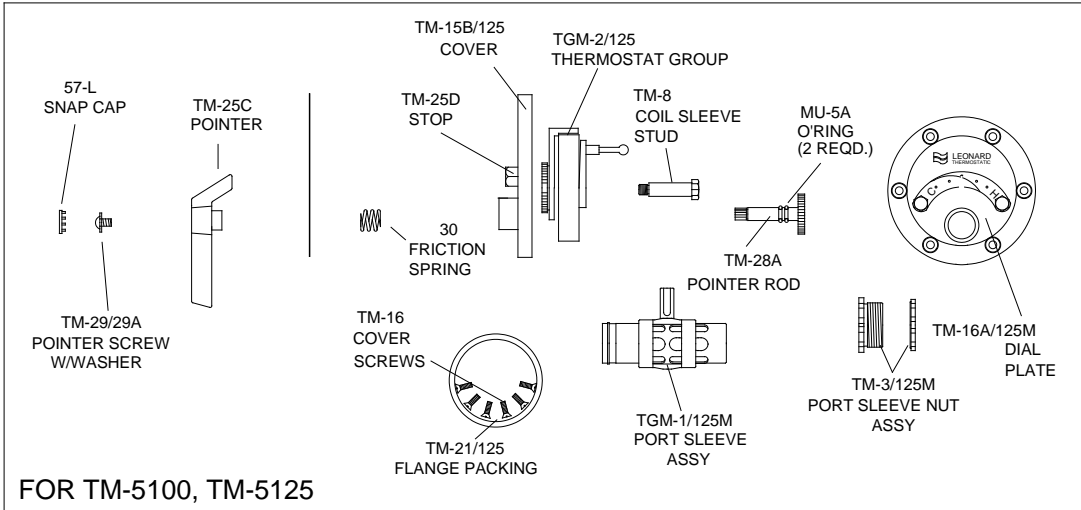

CHECKSTOP PARTS

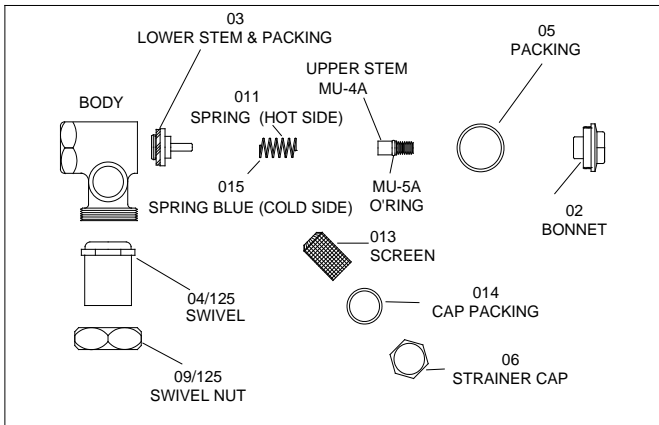

LOCK-TYPE POINTER (SUFFIX LTR)

All TM-5100, 5125 valves are furnished with lockable pointers. See part noted.

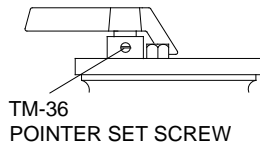

REMEMBER! THIS IS A CONTROL DEVICE WHICH MUST BE CLEANED AND MAINTAINED ON A REGULAR BASIS (SEE MAINTENANCE GUIDE AND RECORD, MGR-1000)

NOTE: AFTER INSTALLING NEW PARTS IT WILL BE NECESSARY TO RESET THE ADJUSTABLE HIGH TEMPERATURE LIMIT STOP (SEE PAGE 2).

REPAIR KITS FOR TM-5100, TM-5125

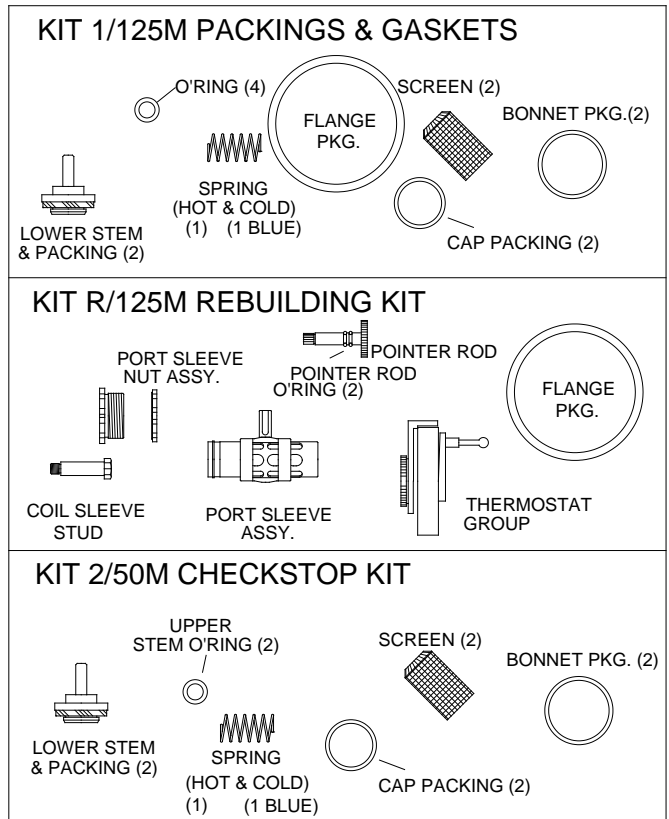

FLOW CAPACITIES

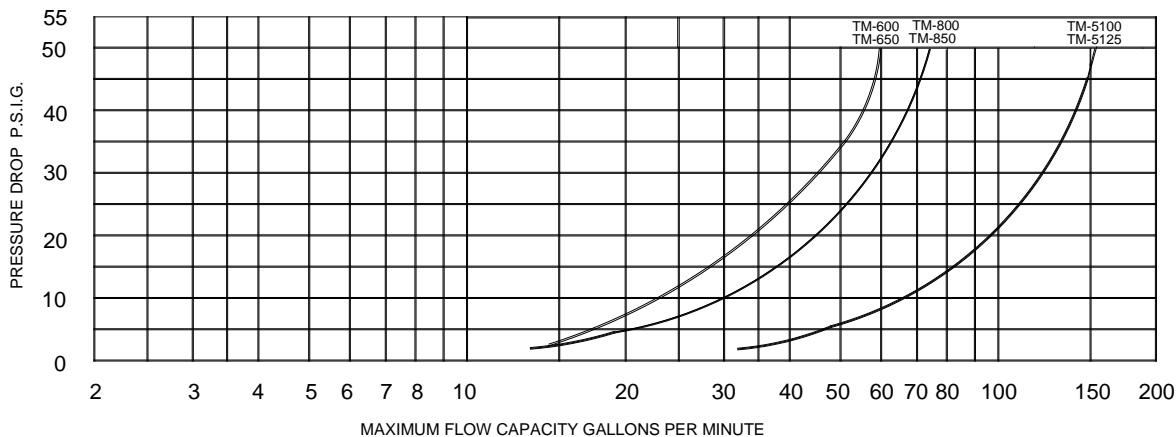

MODEL	IN	OUT	MINIMUM FLOW (GPM)	INTERNAL COLD WATER BY-PASS MINIMUM	SYSTEM PRESSURE DROP										PSI
					5	10	15	20	25	30	35	40	45	BAR	
					.3	.7	1.0	1.4	1.7	2.1	2.4	2.8	3.1		
*TM-600	3/4"	1"	3	20	18	23	29	34	40	45	51	56	58	GPM	
			11	76	68	87	110	129	151	170	193	212	220	LMIN	
TM-650	3/4"	1"	3	20	18	23	29	34	40	45	51	56	58	GPM	
			11	76	68	87	110	129	151	170	193	212	220	LMIN	
*TM-800	1"	1 1/4"	3	20	21	29	38	44	50	53	56	61	64	GPM	
			11	76	79	110	143	167	189	201	212	231	242	LMIN	
*TM-850	1 1/4"	1 1/4"	3	20	21	29	38	44	50	53	56	61	64	GPM	
			11	76	79	110	143	167	189	201	212	231	242	LMIN	
TM-5100	1 1/4"	1 1/2"	3	40	53	64	72	81	90	99	108	117	126	GPM	
			11	151	201	242	273	307	341	374	409	443	477	LMIN	
TM-5125	1 1/4"	1 1/2"	3	40	53	64	72	81	90	99	108	117	126	GPM	
			11	151	201	242	273	307	341	374	409	443	477	LMIN	

MAXIMUM FLOW CAPACITY

LIMITED WARRANTY

Leonard Valve Company warrants the original purchaser that products manufactured by them (not by others) will be free from defects in materials and workmanship under normal conditions of use, when properly installed and maintained in accordance with Leonard Valve Company's instructions, for a period of one year from date of shipment. During this period the Leonard Valve Company will at its option repair or replace any product, or part thereof, which shall be returned, freight prepaid, to the Leonard factory and determined by Leonard to be defective in materials or workmanship. There are no warranties, express or implied, which extend beyond the description contained herein. There are no implied warranties of merchantability or of fitness for a particular purpose. In no event will Leonard be liable for labor or incidental or consequential damages. Any alteration or improper installation or use of the product will void this limited warranty.

1360 Elmwood Avenue, Cranston, RI 02910 USA

Phone: 401.461.1200 Fax: 401.941.5310

Email: info@leonardvalve.com

Web Site: http://www.leonardvalve.com