

FIGURE 320A STAINLESS STEEL BALL VALVES



3 PC FULL PORT 2000 CWP

FEATURES

- 2000 PSI CWP* non-shock
- Working Steam Pressure (WSP)
 - 150 PSI - Fig. 320A
 - 250 PSI - Fig. 320AC
- Full port
- Blowout-proof stem
- Live-loaded packing
- Anti-static design
- Investment cast body
- TFM (super TFE) seats
- End connections
 - Threaded
 - Socket weld
- Stainless steel handle
- Locking lever
- Tapped hole mounting pad
- Vacuum rated to 26.967"Hg (75 Torr)**
- Vented ball
- Manufactured silicone-free
- Replacement locking handle
- Kits available (1/4"-2")
- Optional stem extension kit (uses existing valve handle) (1/4"-2")
- Optional oval handle kit (1/4"-1-1/4")



ACCESSORIES



Replacement Locking Handle Kits (1/4"-3")



Stem Extension Kits (1/4"-2")



Oval Handle Kits (1/4"-1-1/4")

PRODUCT SPECIFICATIONS

Standards

- Design: MSS SP-110
- End Connections:
 - NPT - ASME B1.20.1
 - SW - ASME B16.11
- Seat/Shell Test: MSS SP-110
- Corrosion Resistance: NACE MR0103 and MR0175
- Fugitive Emissions: ISO 15848-1

* 1/4"-1" - 2000 PSI CWP
1-1/4"-2" - 1500 PSI CWP

** Vacuum measurements are often made in inches of mercury below atmospheric pressure. The values calculated here assume standard atmospheric pressure of 29.92 inches of mercury.

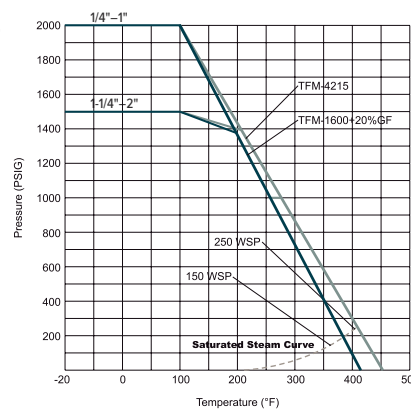

TORQUE (IN-LBS)

Size / ΔP	150 psig	700 psig	1500 psig	2000 psig
	10 Bar	50 Bar	100 Bar	140 Bar
1/4, 3/8	62	62	62	62
1/2	62	62	62	71
3/4	71	71	71	80
1	115	133	133	142
1-1/4	150	195	230	
1-1/2	221	274	328	
2	292	407	487	

Note: 30% safety factor is recommended when sizing actuator.

FIGURE NUMBER MATRIX

FNW 320A			
Seat/Seal Code	End Code	Size Code	
Blank = Standard Temp (150 WSP)	Blank = Threaded NPT	1/4" = B	1" = G
C = High Temp (250 WSP)	SW = Socket Weld	3/8" = C	1-1/4" = H
		1/2" = D	1-1/2" = J
		3/4" = F	2" = K

HANDLE KIT CODES (ORDER SEPARATELY)

FNW 320A	
Kit Type	Size Code
Locking Handle = LHK	1/4"-3/4" = BF
Stem Extension = SEK	1"-1-1/4" = GH
Oval Handle = OH	1-1/2"-2" = JK

REPAIR KITS (ORDER SEPARATELY)

FNW 320A	
Kit Size Code	
1/4"-3/8" = BC	1-1/4" = H
1/2" = D	1-1/2" = J
3/4" = F	2" = K
1" = G	

FIGURE 320A STAINLESS STEEL BALL VALVES



3 PC FULL PORT 2000 CWP

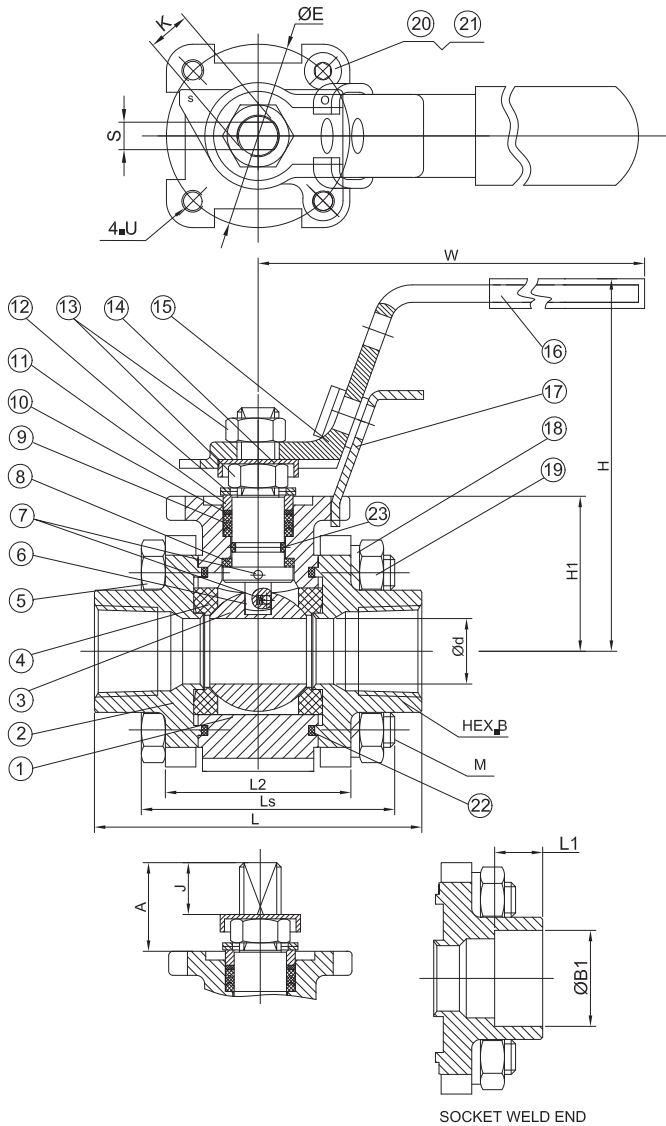

STANDARD MATERIALS

Ref. No.	Description	Material		Qty
		Figure 320A	Figure 320AC	
1	Body	ASTM A351 Gr. CF8M Stainless		1
2	End Cap	NPT	ASTM A351 Gr. CF8M Stainless	2
		SW	ASTM A351 Gr. CF3M Stainless	
3	Ball	316SS Stainless		1
4	Seat	TFM1600+20% GF	TFM4215	2
5	Body Bolt	1/4"-1-1/4"	ASTM A193-B8 Stainless	4
		1-1/2"-2"		8
6	Stem	316SS Stainless		1
7	Anti-Static Device	316SS Stainless		2
8	Thrust Washer	TFM4215		1
9	V-Ring Packing	PTFE	TFM1600	1 Set
10	Bushing	50% Stainless+50% PTFE		1
11	Gland	316SS Stainless		1
12	Belleville Washer	301SS Stainless		2
13	Stem Nut	ASTM A194-8 Stainless		2
14	Stop-Lock-Cap	304SS Stainless		1
15	Handle	304SS Stainless		1
16	Handle Sleeve	Vinyl Plastic		1
17	Lock Device	304SS Stainless		1
18	Bolt Washer	1/4"-1-1/4"	304SS Stainless	4
		1-1/2"-2"		8
19	Bolt Nut	1/4"-1-1/4" ASTM A194-8 Stainless		4
20	Stop Bolt	ASTM A193-B8 Stainless		1
21	Stop Washer	304SS Stainless		1
22	Body Gasket	PTFE	PTFE+20% CF	2
		PTFE	PTFE+20% CF	
23	O-Ring	FKM		1

DIMENSIONS (INCHES)

SIZE	Ød	L	H1	H	W	ØE	S	U	A	J	K (UNF)	Ls	L2	M (UNC)	B	L1	ØB1
1/4	0.42	2.76	1.18	2.99	5.31	1.65	0.25	M5	0.68	0.41	3/8-24	2.13	1.61	1/4-20	0.93	0.43	0.55
3/8	0.50	2.76	1.18	2.99	5.31	1.65	0.25	M5	0.68	0.41	3/8-24	2.13	1.61	1/4-20	0.93	0.43	0.69
1/2	0.59	2.95	1.42	3.27	5.31	1.65	0.25	M5	0.80	0.46	3/8-24	2.44	1.83	5/16-18	1.10	0.43	0.86
3/4	0.79	3.15	1.56	3.27	5.31	1.65	0.25	M5	0.80	0.46	3/8-24	2.74	2.05	3/8-16	1.34	0.51	1.07
1	0.98	3.54	1.79	3.86	6.69	1.97	0.35	M6	0.92	0.49	9/16-18	3.18	2.36	3/8-16	1.81	0.51	1.34
1-1/4	1.25	4.33	1.97	4.06	6.69	1.97	0.35	M6	0.92	0.49	9/16-18	3.86	2.76	1/2-13	2.17	0.51	1.68
1-1/2	1.50	4.72	2.36	4.33	7.87	2.76	0.38	M8	1.18	0.59	5/8-18	4.12	3.24	1/2-13	2.24	0.51	1.91
2	1.95	5.51	2.68	4.69	7.87	2.76	0.38	M8	1.18	0.59	5/8-18	4.90	3.68	5/8-11	2.87	0.63	2.41

CV & WEIGHT

Size	Cv	Wt (lbs)	
		NPT	SW
1/4	16	2.34	2.34
3/8	23	2.34	2.34
1/2	18	2.29	2.25
3/4	36	3.15	3.15
1	96	4.59	4.59
1-1/4	170	7.61	7.61
1-1/2	270	9.92	9.92
2	460	15.21	15.48