

BACK VIEW

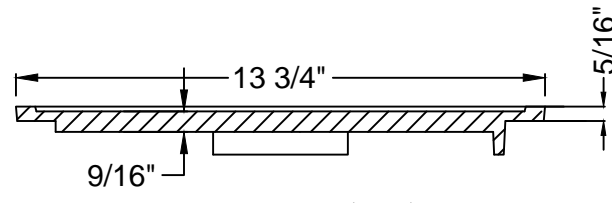

SECTION-"B-B" (LID)

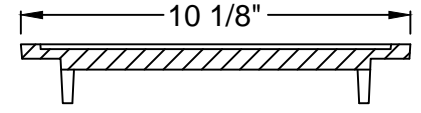

SECTION-"A-A" (LID)

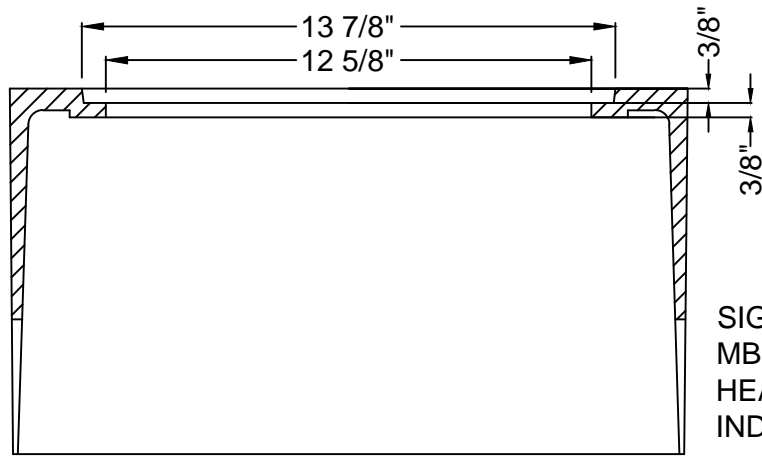

SECTION-"B-B" (BODY)

SIGMA  
MB1672  
HEAT NO.  
INDIA, P #

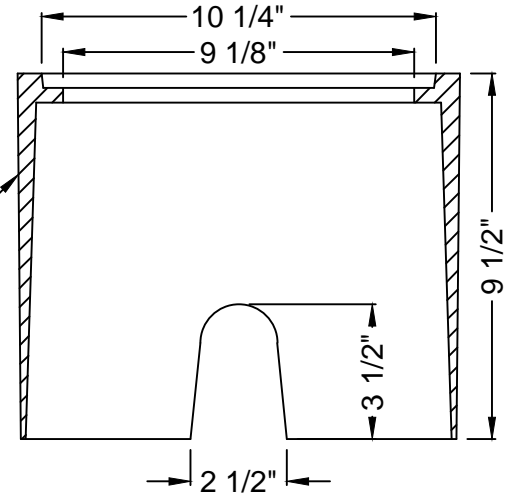

SECTION-"A-A" (BODY)

**Note:-**

1. All the dimensions are in inches.
2. Material: Cast Iron ASTM A48 class 30B
3. Tolerance should be  $\pm 0.0625$ ", unless otherwise specified.
4. Refer Sigma QIP Doc.No : QA/QIP/MCC for manufacturing and inspection procedure.

	Rev	Date	Revision Record	Prepared	Approved	All Radii & Fillets to be 0.12" (3mm) unless otherwise specified All Draft angles to be 2° unless otherwise specified on drawing	CREAM RIDGE, NEW JERSEY			
								Product Group :-	DATE : 04.13.2015	
									MCC	DRAWN BY KSA4/ BASANTA DAS
									Coating:- BLACK BITUMINOUS/ TAR COATED	CHECKED BY ED/ASHIS DEY
									Product Description:- BH 86 EQ. MBX CVR W/O LOCK	DRAWING FOR: SUBMITTAL
						Drawing Number :- MB167	Rev : 0	SCALE: NTS	SHEET NO: 1 OF 1	APPROVED BY SR1

BY RECEIVING THIS DRAWING THE RECEIPT AGREE THAT THIS DRAWINGS AND ITS CONTENTS REMAIN THE SOLE PROPERTY OF SIGMA CORPORATION. THIS DRAWING IS RECEIVED IN CONFIDENCE AND WILL NOT BE REPRODUCED TO SIGMA'S DETRIMENT. THIS DRAWING IS LOANED SUBJECT TO RETURN ON DEMAND.