

## Description

N.F.P.A. 13, 13D and 13R requires the use of an expansion chamber on antifreeze systems with backflow preventers. The TrimFit ET25 is a rubber bladder filled expansion chamber designed for use on antifreeze based fire sprinkler systems. It has been tested and U.L. listed to be compatible with both propylene glycol and glycerin based antifreeze. The expansion chamber regulates pressure caused by thermal expansion and contraction within the closed system.



## Features

- U.L. Listed for Fire Protection Use (UL File Number EX16145)
- Suitable for N.F.P.A. 13, 13D and 13R systems
- Compatible with both glycol and glycerin systems
- Industry leading strength/weight ratio
- 2½ gallon total volume
- Stainless steel construction for long service life
- 1" NPT supply connection
- Pre-charged to 25 psi/175 kPa with Nitrogen\*

\*Pre-charge must be increased for installed system pressure. See Setup Instructions.

**⚠ Safety Alert:** read carefully the installation warnings on the following page. Failure to follow the instructions and warnings may result in serious or fatal injury and/or property damage.

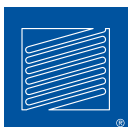

3198 LIONSHEAD AVE  
CARLSBAD, CA 92010  
TEL + 1 760 599-1168  
+ 1 800 344-1822  
FAX + 1 800 344-3775

© 2012 Fire Protection Products, Inc. FPPI<sup>®</sup>.

## Operation

As pressure rises within the system, the excess fluid pressure discharges into the expansion chamber, compressing the gas filled bladder. The bladder absorbs the pressure within the system chamber allowing the antifreeze solution to safely expand, preventing system integrity failures.

## Design

Expansion chambers must be properly sized to perform for the individual conditions present to keep the system pressure below the system component ratings per the 2010 Edition of N.F.P.A. 13 Section 7.6.3.3.1. Refer to N.F.P.A. 13 section A.7.6.3.2 for acceptable formulas and procedures for determining the required acceptance volume of the pre-charged chamber and the chambers total required volume. The sizing graphs are provided as a visual guide for general system size parameters. Sizing of chambers must be performed using the methods described in N.F.P.A. 13.

## Installation Instructions

SEE FOLLOWING PAGE

## Specifications

Design pressure 25-150PSI  
Maximum working pressure:  
175psi

## Materials

Tank: Welded Stainless Steel  
Bladder: Nitrile Rubber

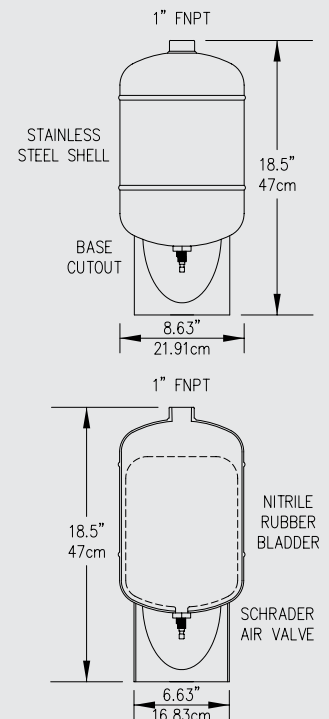

EMPTY WEIGHT: 22.8 LBS (10.34 KG)



## Installation Instructions

The expansion tank must be installed in an easily serviceable and temperature controlled area on the downstream or system side of the backflow preventer or check valve on a trim arrangement that will allow proper filling and testing. The chamber can be installed either on the floor or suspended from the 1" NPT connection with the use of a duct clamp secured to the wall. The chamber must be installed in the vertical upright position only. To facilitate setup and testing, install the chamber per the details provided. The trim arrangement shown will allow testing of the chamber without removing the entire system from service. Connection to the system should be made from the 1" NPT inlet with 1" pipe.

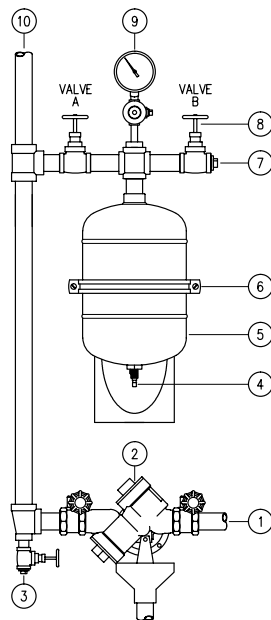

### SUSPENDED FROM TRIM

- ① PIPING FROM WET SIDE OF SPRINKLER SYSTEM
- ② DOUBLE CHECK BACKFLOW PREVENTER OR CHECK VALVE
- ③ ANTIFREEZE SYSTEM DRAIN
- ④ BLADDER FILL CONNECTION SCHRADER AIR VALVE
- ⑤ FPPI 06-025-00 2.5 GALLON LISTED EXPANSION CHAMBER
- ⑥ 8.5" RUBBER LINED DUCT CLAMP ANCHORED TO WALL
- ⑦ TEST AND FILL CONNECTION
- ⑧ 1" GLOBE VALVE (TYPICAL)
- ⑨ 0-300 PSI WATER PRESSURE GAUGE AND GAUGE TEST VALVE
- ⑩ ANTIFREEZE SYSTEM PIPING TO SPRINKLERS

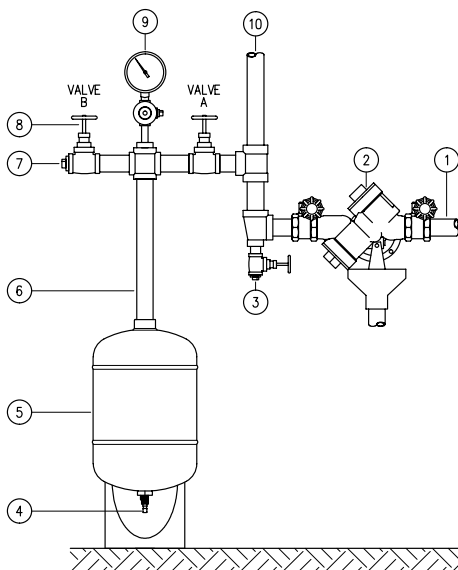

### FREESTANDING ON FLOOR

- ① PIPING FROM WET SIDE OF SPRINKLER SYSTEM
- ② DOUBLE CHECK BACKFLOW PREVENTER OR CHECK VALVE
- ③ ANTIFREEZE SYSTEM DRAIN
- ④ BLADDER FILL CONNECTION SCHRADER AIR VALVE
- ⑤ FPPI 06-025-00 2.5 GALLON LISTED EXPANSION CHAMBER
- ⑥ 1" PIPE CONNECTION TO SYSTEM
- ⑦ TEST AND FILL CONNECTION
- ⑧ 1" GLOBE VALVE (TYPICAL)
- ⑨ 0-300 PSI WATER PRESSURE GAUGE AND GAUGE TEST VALVE
- ⑩ ANTIFREEZE SYSTEM PIPING TO SPRINKLERS

## SETUP INSTRUCTIONS

The following procedure assumes the system is pressurized with antifreeze with the chamber installed on the trim arrangement suggested in the Installation Instructions and per details:

1. Visually inspect the tank for damage.
2. Valve A should be closed and valve B should be unplugged and open.
3. Ensure that the chamber pressure is at zero (a gauge installed per details is advised).
4. The tank ships with the bladder pre-charged to 25 psi/175 kPa from the factory.
5. Attach nitrogen source (-50°F/-46°C dew point or lower) to the tanks valve stem\* and pre-charge to the value 2 psi below the maximum system static pressure. NEVER PRE-CHARGE BELOW 25% OF THE SYSTEMS MAXIMUM RATED PRESSURE OR ABOVE THE BLADDERS MAXIMUM DESIGN PRESSURE.
6. After removing the charging hose, check for leaks and replace the valve stem cap.
7. Close Valve B. Verify trim gauge remains at zero.
8. Introduce antifreeze system pressure to the chamber by slowly opening Valve A to the full open position.
9. Bleed any trapped air in chamber by slightly opening Valve B, then replace plug.
10. Gauge should now read the system static pressure. Check all trim connections for leaks.

*\*Dry compressed air may be used in place of nitrogen. Nitrogen is the preferred gas for maintaining the correct internal pressure inside the bladder due to its inert stability.*

## MAINTENANCE INSTRUCTIONS

The chambers bladder pre-charge should be checked at least annually. All pressure must be removed from the systems chamber to check pre-charge pressure:

1. Close Valve A, remove plug from and slowly open Valve B to relieve chamber pressure.
2. Close Valve B temporarily. Pressure on trim gauge should read zero.
3. Check bladder pressure with an air gauge with a range of 0-175 psi/0-1225 kPa.
4. If bladder pressure is below required pre-charge pressure, re-pressurize with nitrogen or dry air per Setup Instructions. Verify that bladder pressure does not degrade (indicated by an increase in pressure on trim gauge).
5. If bladder pressure reads zero, attempt to re-pressurize to verify if pressure degrades. If pressure is degrading or liquid is present, the bladder or chamber will require replacement.
6. Following satisfactory testing, restore chamber to service per Setup Instructions.

### **⚠ WARNING**

READ CAREFULLY THE FOLLOWING WARNINGS. FAILURE TO FOLLOW THE INSTRUCTIONS AND WARNINGS BELOW MAY RESULT IN SERIOUS OR FATAL INJURY AND/OR PROPERTY DAMAGE, AND WILL VOID THE PRODUCT WARRANTY. THIS PRODUCT MUST BE INSTALLED BY A QUALIFIED PROFESSIONAL. FOLLOW ALL APPLICABLE LOCAL AND STATE CODES AND REGULATIONS, IN THE ABSENCE OF SUCH CODES, FOLLOW THE CURRENT EDITIONS OF THE NFPA CODE, AS APPLICABLE.

Excessive pressure can cause tank to explode. Exercise care not to pressurize the tank beyond what is required or the working pressure of the tank as stamped on the nameplate.

Like most products under pressure, this product may over time corrode, weaken and explode or burst. To reduce the risk, a licensed professional must install and periodically test and service the product and install a relief valve to prevent pressure in excess of local code requirements or maximum working pressure of the tank, whichever is less.

Operating Temp: 35° - 200° F

A drip pan connected to an adequate drain must be installed if leaking or flooding could cause property damage. Do not locate in an area where leakage of the tank or connections could cause property damage to the area adjacent to the appliance or to lower floors of the structure.

Antifreeze systems, the solutions required for freeze protection and the workmanship of the installation should be carefully designed and monitored to provide protection for the spaces intended. A properly designed and maintained expansion chamber is one component of a system that relies on multiple factors to perform as intended. Careful analysis of the protected space, system parameters and installation location of the chamber will result in an adequately sized chamber. NEVER MIX ANTI-FREEZE TYPES. NEVER INTRODUCE PROPYLENE GLYCOL INTO A CPVC SYSTEM OR LOOP. NEW RULES ARE NOW IN EFFECT FOR ANTI-FREEZE USE. PLEASE REVIEW NFPA TIA'S FOR THE MOST CURRENT RULES REGARDING ANTI-FREEZE USE.

## Bladder Expansion Tank Sizing Graphs 2½ Gallon Model

GLYCERINE

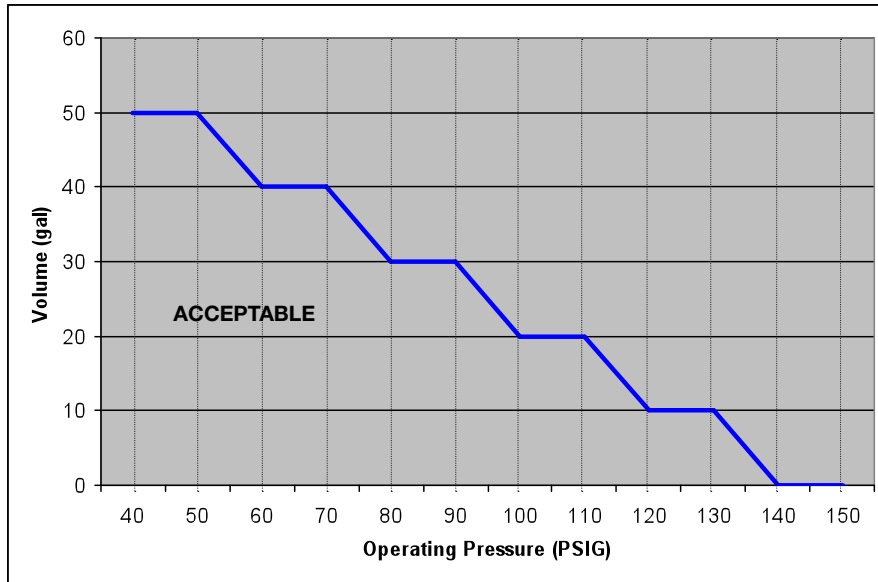

PROPYLENE GLYCOL

