

Low Water Cutoff (LWCO) IQ Option Card

p/n 102711-01, 102714-01 for Hot Water Boilers

APPLICATION

The Low Water Cutoff (LWCO) IQ Option Cards are advanced, microprocessor based low water cutoffs for detecting the absence of water in a heating system. LWCO IQ Option Cards use patented signal processing to identify when the probe signal levels have decreased due to possible fouling. This advanced technologies permit extended operation for probe impedances up to 40K Ohms. The LWCO IQ Option Cards function longer without requiring probe cleaning, and function normally under non-ideal installation conditions.

This product may be applied to either gas or oil fired hot water boilers equipped with the IQ Control System. The LWCO IQ Option card may be simply “plugged in” to the IQ Option Panel and only requires probe installation and prefabricated probe wire connection to become operational.

GENERAL

The LWCO IQ Option Cards are available in automatic or manual reset models. Automatic reset versions automatically reset when water levels return to safe levels. Manual reset models require user intervention to reset a low water condition after water levels return to safe levels. Manual reset models will not “lock out” upon power loss provided water still covers the probe when power returns.

SPECIFICATIONS

Listings/Approvals:

- UL GUIDE (MBPR2) for Limit Controls per UL Standard 353 Limit Controls—Component
- UL GUIDE (MBPR8) Controls, Limit Certified for Canada—Component per CSA Standard C22.2
- Apply a Manual Reset LWCO IQ Option Card, p/n 102714-01 to be Fully compliant with CSD-1 requirements for water level controls in the US and Canada

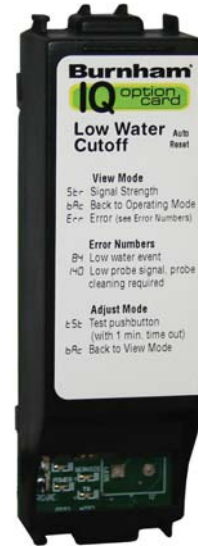

Max Probe Ratings:	Hot water only - 250 psi (17.6kg/cm ²) at 250°F (121°C)
Probe Sensitivity:	20K Ohms. Extended operation to 40K Ohms.
Thresholds:	< 16% = Low Water Event < 35% = Probe Cleaning may be required
Operating Temperature:	-4°F to 150°F (-20°C to 66°C)
Enclosure Rating:	NEMA 1 for indoor use only
Dimensions:	4.5 in. x 1.5 in. (fits onto IQ Option Panel)
Input Power:	1.7 VA @ 24 VAC supplied by a Class 2 power source
Reset:	Automatic or manual reset modes
Testing:	Adjustment mode Test (⚡5⚡) pushbutton permits user testing
US Patents:	6,904,800, 7,243,540, and 7,317,993, Other Patents Pending

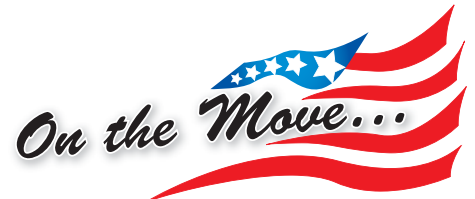

NOTICE

When Installing this Product:

1. Read these instructions carefully. Failure to follow them could damage the product or cause a hazardous condition. Save instructions for future use.
2. Check the ratings given in the instructions and on the product to make sure the product is suitable for your application.
3. Installer must be a trained, experienced service technician.
4. After installation is complete, check out product operation as provided in these instructions.

! WARNING

- Installation must be performed by qualified personnel and in accordance with all national and local codes and ordinances by qualified personnel.
- When installations are complete, check for correct operation of ALL limit and operating controls.
- Wire insulation must be rated at 221° F (105° C) or greater, over copper conductors only. Use of other wire or insulation types could result in fire causing property damage, serious injury, and death.
- Hot water controls are for use with hot water boilers and hot water heating boilers only. Use on steam boilers could cause improper operation resulting in property damage, serious injury, and death.
- Hot or pressurized boiler systems can discharge steam and hot water. Cool boiler system to 80° F (27° C) and to 0 psi (0 bar) before servicing. Failure to do so could result in serious burns.
- Shock hazard. Disconnect power source before servicing, installation, and wiring. Serious injury or death could result. Failure to disconnect may cause electrical shock or equipment damage. Wiring must comply with applicable codes, ordinances and regulations.

! CAUTION

- Do not mount device with probe angled upward. Deposits can accumulate on the probe.
- Only mount with the probe facing horizontally or vertically downward. Maintain 1/4" minimum clearance from electrode and pipe wall.
- Only use pipe thread sealant for sealing probe threads. Do not use Teflon tape. Teflon tape can insulate the probe electrically, and cause improper device operation. This can cause damage to equipment or property.
- Failure to install probe as directed can cause improper operation and damage to equipment and property.

Fig. 1

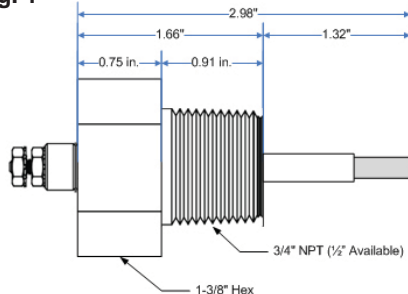

Fig. 2

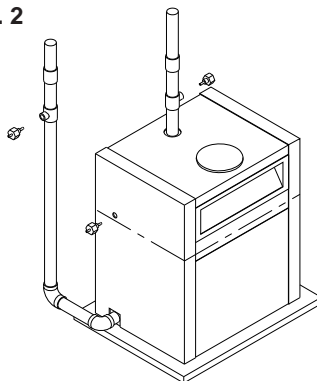
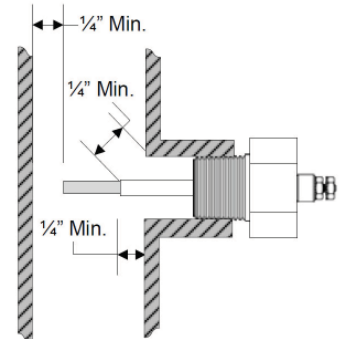

Fig. 3



INSTALLATION (continued)

Probe Installation

1. Install the probe above the minimum safe water level, determined by the boiler manufacturer's literature. This may be in a tapping on the boiler, in the boiler supply, or return piping. (See Fig. 3)
2. Make sure the probe extends into the boiler cavity or piping to make contact with the boiler water.
3. Make sure the exposed portion of the stainless steel probe is a minimum of 1/4" from any grounding surface inside the boiler to prevent the probe from shorting. (See Fig. 2)
4. Tighten the LWCO into the process connection using wrenching flats on bushing. Make sure not to cross-thread. Only use pipe thread sealant.

IQ Option Card Installation

1. Turn off power to the boiler before installing the option card
2. Select an unoccupied IQ Option Panel slot and carefully insert pins on the IQ Option Panel header into the connector on the bottom of the option card.

CAUTION

- Use caution not to bend the pins

3. Gently push the option card into the IQ Option Panel option slot until it locks into place. The IQ Option Panel will automatically recognize the option card and establish communication after power is turned back on.



Insert IQ Option Card into selected slot

Wiring

1. Using wiring harness provided in probe kit, connect the female quick disconnect to the "Probe" terminal on the LWCO IQ Option Card. See figure 4.
2. Route wire to probe location. Take care to not damage insulation and avoid running wire over sharp edges and corners.
3. Remove the outer probe locknut taking care to not turn the second locknut. See Figure 4 for location.
4. Place ring terminal over the electrode.
5. Secure outer locknut to complete wiring of the probe.
6. Test the system as indicated below.

Fig. 4 Wiring

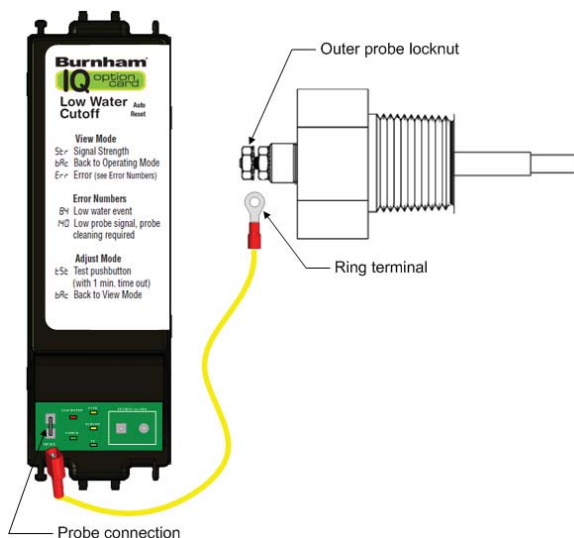

WARNING

- Shock hazard. Disconnect power source before servicing. Serious injury or death could result.

INSTALLATION (continued)

Testing

1. Do NOT fill the boiler with water. Set the thermostat to the lowest setting. Turn electric power on to the boiler. On initial start-up, the LWCO indicates a low water condition, which indicates proper function. The “Low Water” LED on the control unit illuminates RED and the Power LED illuminates GREEN. NOTE: The burner should not operate without water in the system.
2. Fill the boiler with water. When water covers the probe, the RED “Low Water” LED on the control turns off.
3. Set the thermostat to call for heat and make sure that the burner ignites.
4. With the burner “on”, activate the test feature (“How To Test the LWCO” on page 6) while observing the burner and the “Low Water” LED on the Control. After the “Low Water” LED illuminates RED, the burner should turn off.
5. Wait 1 minute (for test period to end) and verify that the burner ignites (provided water covers the probe). The RED “Low Water” LED on the control unit turns off.
6. If the burner fails to cutoff or relight, see the Troubleshooting section for details. If operation is normal, set the thermostat to the normal setting.

Once correct operation of the LWCO has been tested, test all other safety, limit, and control devices before finalizing system operation.

USER INTERFACE

LWCO Features

LED	Description
Green Power	Power indicator
Red Low Water	Low water/fault indicator
Amber Service	Service required indicator
Green TX	Enviracom® communication indicator

LED States*

Red Low Water LED	Amber Service LED	Meaning
Off	Off	Normal
On	Off	Low Water Condition
Off	On	Safe water level, weak probe signal – Clean Probe Soon.
On	On	Probe signal too weak, low water condition – Service Probe Now
Blinking	Off or On	Control failure. Lockout in low water state.

* States with GREEN “Power” LED turned on. All LED’s off indicates no power to control.

Probe Connection And Led Diagram

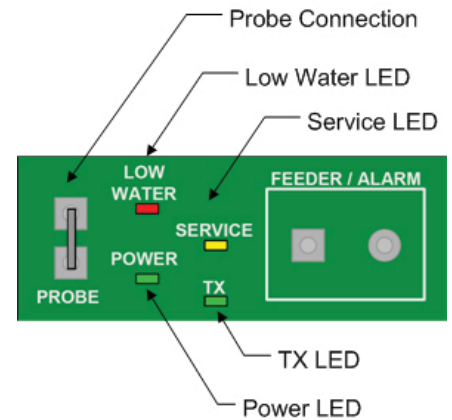

During a low water condition, the “LOW WATER” LED will illuminate RED. In normal conditions, it turns off. If the LWCO detects a low signal level from the probe, the “SERVICE” LED will illuminate AMBER to signal that probe cleaning may be required.

USER INTERFACE (continued)

Using IQ Option Panel Display

The IQ Option Panel display along with Up ↑, Down ↓, and “I” keys are used to view and adjust IQ Option Card settings. Please note that these keys look similar to the keys on the IQ Boiler Control but are in a different orientation, and they perform different functions.

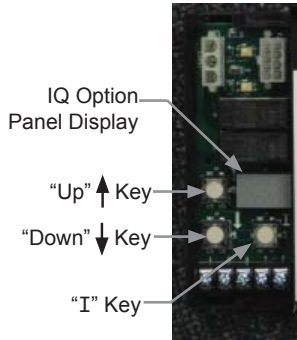

IQ Option Panel User Interface

Selecting IQ Option Card

To access an IQ Option Card:

1. Press the “I” key. The display will go from “OFF” to [1, [2, and [3 (when cards are installed) to provide access to each of the card slots and the card plugged into that slot.
2. Press either the Up ↑ or Down ↓ keys when the display shows the card number where the LWCO card is installed. For example, if the LWCO card is installed in slot one, press the Up ↑ or Down ↓ keys when “[1” is displayed. This switches the display to show the IQ Option Card View Mode.

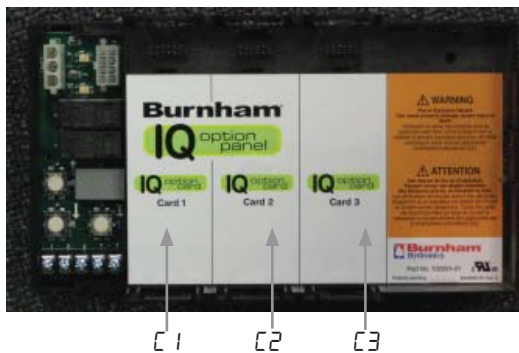

IQ Option Panel Card Slot

Showing View Mode Options

In view mode the user may look at (but not change) status and probe signal strength. To view option card information, press and release the “I” button. The following table shows the items that will be displayed in view mode:

View Mode Options

St _r	LWCO signal strength displayed as a % of full strength. (0 – 100%)
b _{AC}	Return to IQ Option Panel Menu
Err	Error, followed by error number: 84 Low Water Event 140 Low Probe Signal 141 Lockout, manual reset required (refer to Trouble Shooting Section for more information)

Each item will alternately flash between the relevant display code and it’s corresponding value. For example, when the “I” key is pressed until “St_r” is displayed, it will then flash a display a number (such as “95”). This indicates that the signal strength is 95%. Other view mode items display information in a similar fashion.

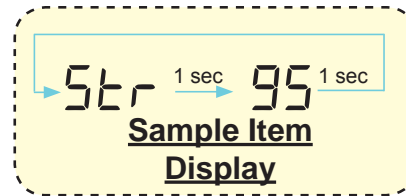

To hold the display on the value in view mode, press and hold either the Up ↑ or Down ↓ keys and the value will be continuously shown. This may be helpful in watching a value “live”.

To exit view mode and return to the IQ Option Panel menu:

1. Press the “I” button to select the “b_{AC}” menu item.
2. Press either the Up ↑ or Down ↓ keys to exit the card menu.

Entering Adjustment Mode

In Adjustment Mode, the user can activate the test mode of the LWCO and reset a low water condition for Manual Reset models. To enter adjustment mode:

1. Press and hold the Up ↑, Down ↓, and “I” keys simultaneously for three (3) seconds while the display is in the LWCO card View Mode. While holding the buttons the display will change to an Adjustment mode label signifying to the user that installer mode has been entered. This procedure is intended to discourage unauthorized or accidental changes to parameter settings.
2. After entering Adjustment Mode, Press the “I” key to view the test or reset function.
3. Press the Up ↑ or Down ↓ keys to activate reset or test functions. The following table shows adjustable items.

Adjustment Mode Options	
t5t	<p>Test Pushbutton The test feature remains active for 1 minute before automatically turning off. To manually turn the test off, Press the Up ↑ or Down ↓ keys while test is active</p> <p>on Test Mode is active. off Test Mode is not active</p>
r5t	<p>Reset from lockout (manual reset only)</p> <p>on Ready to restore from lockout off Not Ready to restore from lockout</p>
bRc	<p>Return to Option Card View Mode Menu</p>

4. Exit adjustment mode by one of the following means:
 - Press the “I” key until “bRc” option is displayed and press either Up ↑ or Down ↓ keys
 - Press and Hold the Up ↑, Down ↓, and “I” keys until the first item of view mode is shown.
 - If no keys are pressed, after five (5) minutes the display will automatically return to the view mode.
5. Once in view mode press the “I” key until “bRc” option is displayed and press either Up ↑ or Down ↓ keys to return to the IQ Option Panel Display.

Testing the Low Water Cutoff

1. Follow Boiler’s Operating Instructions to place boiler in operation. (refer to boiler instruction manual)
2. Press “I” key until the LWCO Card slot number is displayed (C1, C2, or C3).
3. Press the Up ↑ or Down ↓ keys to enter the card’s view mode
4. Press and Hold the Up ↑, Down ↓, and “I” keys simultaneously for three (3) seconds, Adjustment Mode items will be shown
5. Press “I” until the Test (t5t) Pushbutton is shown.
6. Press the Up ↑ or Down ↓ keys to turn test “on”
7. Resulting Test Sequence:

Test Sequence	IQ Boiler Control Display	IQ Option Panel Display
1. Safety Relays “Open”	5tR 15	OL
2. Boiler turns “Off”	5tR 15	OL
3. After 1 minute	5tR 15	OL
4. Safety Relays “Close”		O.C.P.
5. Boiler turns “On”	5tR 8	O.C.P.

5tR 15 = Waiting for Limit to Close Open Limit
 OL = Open Limit
 O.C.P. = Normal Operation - Run Mode

Resetting the LWCO

1. Make sure that the water level has returned to normal and water is covering the LWCO probe.
2. Press “I” key until the LWCO Card slot number is displayed (C1, C2, or C3).
3. Press the Up ↑ or Down ↓ keys to enter the card’s view mode.
4. Press and Hold the Up ↑, Down ↓, and “I” keys simultaneously for three (3) seconds, Adjustment Mode items will be shown
5. Press “I” until the Reset (r5t) Pushbutton is shown.
6. Press the Up ↑ or Down ↓ keys to turn Reset “on”

NOTICE
Resetting lockout only applies to Manual Reset Models.

CLEANING, MAINTENANCE, AND REPLACEMENT

- Test the operation of the LWCO annually (or more frequently) by activating the Test feature. The “Low Water” LED should turn RED and the boiler should shut down.
- Inspect the probe every 5 years for scale build-up or coating. Clean all oils, fluxes, and scale from the probe using a clean rag.

NOTICE

Inspect the probe sooner if the “Service” LED comes on.

- Replace the control unit every 15 years. In areas of high humidity, heavy dust, or other airborne contaminants, it may be necessary to replace the control unit more frequently.

ORDERING INFORMATION

Part Number	Description
102711-01	LWCO Limit Control IQ Option Card kit, Hot Water LF Module, Automatic Reset, for use with Option Control Panel, With Probe, ¾ inch NPT, Instructions, Unit Pack
102714-01	LWCO Limit Control IQ Option Card kit, Hot Water LF Module, Manual Reset, for use with Option Control Panel, With Probe, ¾ inch NPT, Instructions, Unit Pack
102301-01	LWCO Limit Control IQ Option Card, Hot Water LF Module, Automatic Reset, for use with Option Control Panel, Less Probe, Unit Pack
102302-01	LWCO Limit Control IQ Option Card, Hot Water LF Module, Manual Reset, for use with Option Control Panel, Less Probe, Unit Pack
102305-01	LWCO Probe, ¾ inch NPT

TROUBLESHOOTING

Status	Possible Cause	Boiler / Control Action(s)
Boiler will not fire	No power to LWCO or OCP	Make sure that the LWCO is plugged into the OCP correctly and that all wiring is correct. Make sure power to boiler is turned on.
	Low water level	Make sure that the water level has reached the probe.
	Air pocket at LWCO probe	Turn off power to the boiler and slowly loosen, but do not remove the probe. Allow any air to escape until water seeps past the probe's threads. Promptly re-lighten the probe and supply power to the boiler.
	Dirty probe	Fluxes or oils used during the construction of the boiler or installation of system piping can coat the probe, preventing signals from being received by the LWCO. Add a cleaning solution, (such as water and trisodium phosphate or consult the boiler manufacturer), to the system. Heat and circulate this solution for at least one hour before draining and completely flushing the system with clean water. Remove the probe and thoroughly wipe it with a clean rag. Refill the system and test for proper operation.
	Improper ground	Make sure the probe is electrically connected to the ground connection on the OCP.
	Improper wiring	Check all wiring to the OCP and LWCO probe connection and refer to the wiring diagrams. Using a multi-meter, verify that incoming power is 24 VAC.
	Failed control	If the "Low Water" LED blinks RED, the safety circuits in the LWCO have detected a failure in the control. To remove any temporary conditions, turn off the power. After 30 seconds, restore the power. If the "Low Water" LED continues to blink RED, the control must be replaced.
Boiler will not shutdown	Shorted probe	Turn off power to the boiler and remove the probe. Verify that there is at least ¼" clearance from all metal surfaces to the metal probe. Metal from the boiler or piping must not come in contact with the metal probe.
	Improper wiring	Check wiring to the probe and refer to the wiring diagrams. Using a multi-meter, make sure that incoming power to the OCP is 24 VAC.
Amber "SERVICE" LED is on	Dirty probe	Deposits form over time in the system and can coat the probe, preventing signals from being received by the LWCO. Remove the probe and thoroughly wipe it with a clean rag. Refill the system and test for proper operation. It may be necessary to clean the boiler and piping as noted above.