



Compact Fluorescent

Non-Metallic

Outdoor

ENERGY STAR® qualified

Type _____
 -30WB -31WB

P5881

Catalog No.	Finish		Lamping	Dimensions (Inches)			
	White	Black		A	B	C	D
P5881	-30WB	-31WB	1 GU-24 18w (included)	6	8-7/8	6-7/8	4-1/8

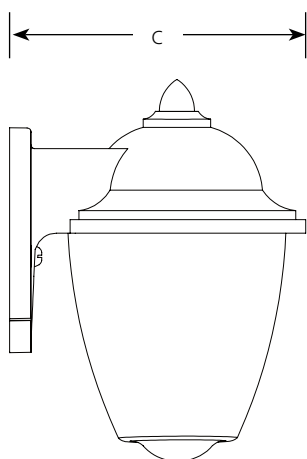

Side

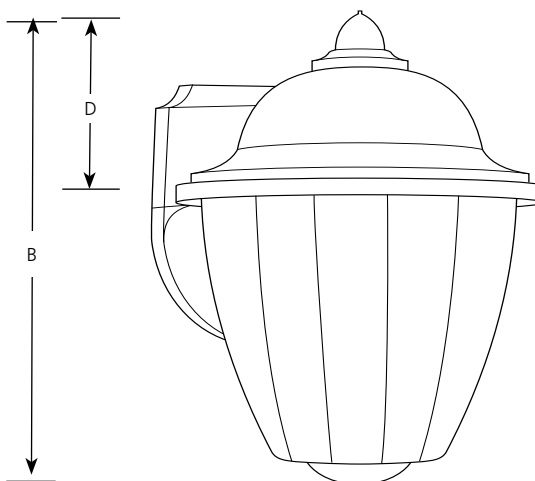

Specifications:

General

- White acrylic acorn style diffuser: 5" dia., 5-5/16" ht.
- Diffuser twists out for lamp replacement
- Polypropylene construction
- White (-30WB) or Black (-31WB) material
- ENERGY STAR® qualified

Electrical

- GU24 base socket
- Pre-wired

Labeling

- UL-CUL Wet location listed

Mounting

- Wall mount
- Back plate covers a standard 4" hexagonal recessed outlet box: 4-7/16" W., 5-1/4" ht.
- Mounting strap for outlet box included



Progress Lighting
 701 Millennium Blvd.
 Greenville, South Carolina
 29607

www.progresslighting.com

Rev. 06/14