

# INSTALLATION INSTRUCTIONS

## HYDRONIC AIR HANDLER

RHWB-



**RECOGNIZE THIS SYMBOL AS AN INDICATION OF IMPORTANT SAFETY INFORMATION!**



### ▲ WARNING

THESE INSTRUCTIONS ARE INTENDED AS AN AID TO QUALIFIED SERVICE PERSONNEL FOR PROPER INSTALLATION, ADJUSTMENT AND OPERATION OF THIS UNIT. READ THESE INSTRUCTIONS THOROUGHLY BEFORE ATTEMPTING INSTALLATION OR OPERATION. FAILURE TO FOLLOW THESE INSTRUCTIONS MAY RESULT IN IMPROPER INSTALLATION, ADJUSTMENT, SERVICE OR MAINTENANCE, POSSIBLY RESULTING IN FIRE, ELECTRICAL SHOCK, CARBON MONOXIDE POISONING, EXPLOSION, PROPERTY DAMAGE, PERSONAL INJURY OR DEATH.

### ▲ WARNING

PROPOSITION 65 WARNING: THIS PRODUCT CONTAINS CHEMICALS KNOWN TO THE STATE OF CALIFORNIA TO CAUSE CANCER, BIRTH DEFECTS OR OTHER REPRODUCTIVE HARM.



**DO NOT DESTROY THIS MANUAL. PLEASE READ CAREFULLY AND KEEP IN A SAFE PLACE FOR FUTURE REFERENCE BY QUALIFIED SERVICE PERSONNEL.**



# SAFETY INFORMATION

## ▲ WARNING

WHEN AN AIR HANDLER IS INSTALLED SO THAT SUPPLY DUCTS CARRY AIR CIRCULATED BY THE AIR HANDLER TO AREAS OUTSIDE THE SPACE CONTAINING THE AIR HANDLER, THE RETURN AIR SHALL ALSO BE HANDLED BY DUCT(S) SEALED TO THE AIR HANDLER CASING AND TERMINATING OUTSIDE THE SPACE CONTAINING THE AIR HANDLER.

## ▲ WARNING

INSTALLATION MUST COMPLY WITH ALL INSTALLATION INSTRUCTIONS INCLUDING:

- AIR HANDLER OPERATING UNDER THERMOSTATIC CONTROL;
- RETURN AIR DUCT SEALED TO THE AIR HANDLER;
- AIR FILTERS IN PLACE;
- RETURN AIR TEMPERATURE MAINTAINED BETWEEN 55°F (13°C) AND 80°F (27°C); AND
- CLEAN AIR HANDLER, DUCT WORK AND COMPONENTS UPON SUBSTANTIAL COMPLETION OF THE CONSTRUCTION PROCESS, AND VERIFY AIR HANDLER OPERATING CONDITIONS INCLUDING FLOW RATE AND TEMPERATURE RISE, ACCORDING TO THE INSTRUCTIONS.

## NOTICE

IMPROPER INSTALLATION, OR INSTALLATION NOT MADE IN ACCORDANCE WITH THE UNDERWRITERS LABORATORY (UL) CERTIFICATION OR THESE INSTRUCTIONS, CAN RESULT IN UNSATISFACTORY OPERATION AND/OR DANGEROUS CONDITIONS AND ARE NOT COVERED BY THE UNIT WARRANTY.

## ▲ WARNING

DUCT LEAKS CAN CREATE AN UNBALANCED SYSTEM AND DRAW POLLUTANTS SUCH AS DIRT, DUST, FUMES AND ODORS INTO THE HOME CAUSING PROPERTY DAMAGE. FUMES AND ODORS FROM TOXIC, VOLATILE OR FLAMMABLE CHEMICALS, AS WELL AS AUTOMOBILE EXHAUST AND CARBON MONOXIDE (CO), CAN BE DRAWN INTO THE LIVING SPACE THROUGH LEAKING DUCTS AND UNBALANCED DUCT SYSTEMS CAUSING PERSONAL INJURY OR DEATH (SEE FIGURE 2).

- IF AIR-MOVING EQUIPMENT OR DUCTWORK IS LOCATED IN GARAGES OR OFF-GARAGE STORAGE AREAS - ALL JOINTS, SEAMS, AND OPENINGS IN THE EQUIPMENT AND DUCT MUST BE SEALED TO LIMIT THE MIGRATION OF TOXIC FUMES AND ODORS INCLUDING CARBON MONOXIDE FROM MIGRATING INTO THE LIVING SPACE.
- IF AIR-MOVING EQUIPMENT OR DUCTWORK IS LOCATED IN SPACES CONTAINING FUEL BURNING APPLIANCES SUCH AS WATER HEATERS OR BOILERS - ALL JOINTS, SEAMS, AND OPENINGS IN THE EQUIPMENT AND DUCT MUST ALSO BE SEALED TO PREVENT DEPRESSURIZATION OF THE SPACE AND POSSIBLE MIGRATION OF COMBUSTION BYPRODUCTS INCLUDING CARBON MONOXIDE INTO THE LIVING SPACE.

## NOTICE

APPLICATION OF THIS HYDRONIC AIR HANDLER SHOULD BE INDOORS. SPECIAL ATTENTION SHOULD BE GIVEN TO UNIT SIZING AND PIPING, FILLING, AND PURGING.

## CAUTION

FAILURE TO FOLLOW THIS CAUTION MAY RESULT IN PERSONAL INJURY. SHEET METAL PARTS MAY HAVE SHARP EDGES OR BURRS. USE CARE AND WEAR APPROPRIATE PROTECTIVE CLOTHING.

## ▲ CAUTION

WHEN USED IN COOLING APPLICATIONS, EXCESSIVE SWEATING MAY OCCUR WHEN UNIT IS INSTALLED IN AN UNCONDITIONED SPACE. THIS CAN RESULT IN PROPERTY DAMAGE.

## NOTICE

IN COMPLIANCE WITH RECOGNIZED CODES, IT IS RECOMMENDED THAT AN AUXILIARY DRAIN PAN BE INSTALLED UNDER ALL EVAPORATOR COILS AND UNITS CONTAINING EVAPORATOR COILS AND AIR HANDLERS USED WITH EVAPORATOR COILS THAT ARE LOCATED IN ANY AREA OF A STRUCTURE WHERE DAMAGE TO THE BUILDING OR BUILDING CONTENTS MAY OCCUR AS A RESULT OF AN OVERFLOW OF THE COIL DRAIN PAN, A STOPPAGE IN THE PRIMARY CONDENSATE DRAIN PIPING OR ANY WATER LEAK POTENTIAL FROM THE AIR HANDLER.

## ▲ WARNING

DO NOT OPERATE THE SYSTEM WITHOUT FILTERS. A PORTION OF THE DUST ENTRAINED IN THE AIR MAY TEMPORARILY LODGE IN THE DUCT RUNS AND AT THE SUPPLY REGISTERS. THIS RESIDUE COULD SOIL CEILINGS, WALLS, DRAPES, CARPETS AND OTHER ARTICLES IN THE HOUSE.

SOOT DAMAGE MAY OCCUR WITH FILTERS IN PLACE, WHEN CERTAIN TYPES OF CANDLES, OIL LAMPS OR STANDING PILOTS ARE BURNED.

## ▲ CAUTION

HORIZONTAL UNITS MUST BE CONFIGURED FOR RIGHT HAND AIR SUPPLY OR LEFT HAND AIR SUPPLY. HORIZONTAL DRAIN PAN MUST BE LOCATED UNDER INDOOR COIL. FAILURE TO USE THE DRAIN PAN CAN RESULT IN PROPERTY DAMAGE.

## ▲ NOTICE

CODES AND STANDARDS: IT IS THE RESPONSIBILITY OF THE INSTALLER TO FOLLOW ALL NATIONAL CODES, STANDARDS AND LOCAL ORDINANCES, IN ADDITION TO INSTRUCTIONS LAID OUT IN THIS MANUAL. THE INSTALLATION MUST COMPLY WITH REGULATIONS OF THE LOCAL BUILDING, HEATING, PLUMBING, AND OTHER CODES. WHERE LOCAL CODES ARE NOT APPLICABLE, THE INSTALLATION MUST COMPLY WITH THE NATIONAL CODES AND ANY AND ALL AUTHORITIES HAVING JURISDICTION.

**▲ WARNING**

**IMPORTANT:** All manufacturer products meet current Federal OSHA Guidelines for safety. California Proposition 65 warnings are required for certain products, which are not covered by the OSHA standards.

California's Proposition 65 requires warnings for products sold in California that contain, or produce, any of over 600 listed chemicals known to the State of California to cause cancer or birth defects such as fiberglass insulation, lead in brass, and combustion products from natural gas.

All "new equipment" shipped for sale in California will have labels stating that the product contains and/or produces Proposition 65 chemicals. Although we have not changed our processes, having the same label on all our products facilitates manufacturing and shipping. We cannot always know "when, or if" products will be sold in the California market.

You may receive inquiries from customers about chemicals found in, or produced by, some of our heating and air-conditioning equipment, or found in natural gas used with some of our products. Listed below are those chemicals and substances commonly associated with similar equipment in our industry and other manufacturers.

- Glass Wool (Fiberglass) Insulation
- Carbon Monoxide (CO)
- Formaldehyde
- Benzene

More details are available at the Websites for OSHA (Occupational Safety and Health Administration), at [www.osha.gov](http://www.osha.gov) and the State of California's OEHHA (Office of Environmental Health Hazard Assessment), at [www.oehha.org](http://www.oehha.org). Consumer education is important since the chemicals and substances on the list are found in our daily lives. Most consumers are aware that products present safety and health risks, when improperly used, handled and maintained.

**CONTENTS**

Safety Precautions ..... 1

Safety Information ..... 2

General Information..... 4

Location Requirements and Considerations ..... 6

Selection Procedure ..... 8

Ducting ..... 12

Installation ..... 14

Plumbing..... 15

Electrical Wiring..... 18

Accessories ..... 18

Sequence of Operation ..... 22

Maintenance ..... 24

Troubleshooting..... 26

Wiring Diagrams..... 27-28

---

**PROHIBITED APPLICATIONS**

RHWB HYDRONIC AIR HANDLERS WITH OPTION CODE 414 ARE REQUIRED FOR INSTALLATION IN CALIFORNIA PER AB1953. OPTION CODE 414 IS ALSO REQUIRED IN VERMONT, PER SB152 FOR USE OF THIS AIR HANDLER IN AN OPEN SYSTEM WITH POTABLE WATER.

---

**IMPORTANT:** TO ENSURE PROPER INSTALLATION AND OPERATION OF THIS PRODUCT, COMPLETELY READ ALL INSTRUCTIONS PRIOR TO ATTEMPTING TO ASSEMBLE, INSTALL, OPERATE, MAINTAIN OR REPAIR THIS PRODUCT. UPON UNPACKING OF THE AIR HANDLER, INSPECT ALL PARTS FOR DAMAGE PRIOR TO INSTALLATION AND START-UP.

---

# GENERAL INFORMATION

**FIGURE 1**  
**UPFLOW AIR HANDLER**  
 THE RWHB SERIES HYDRONIC AIR HANDLERS ARE DESIGN-CERTIFIED BY UL

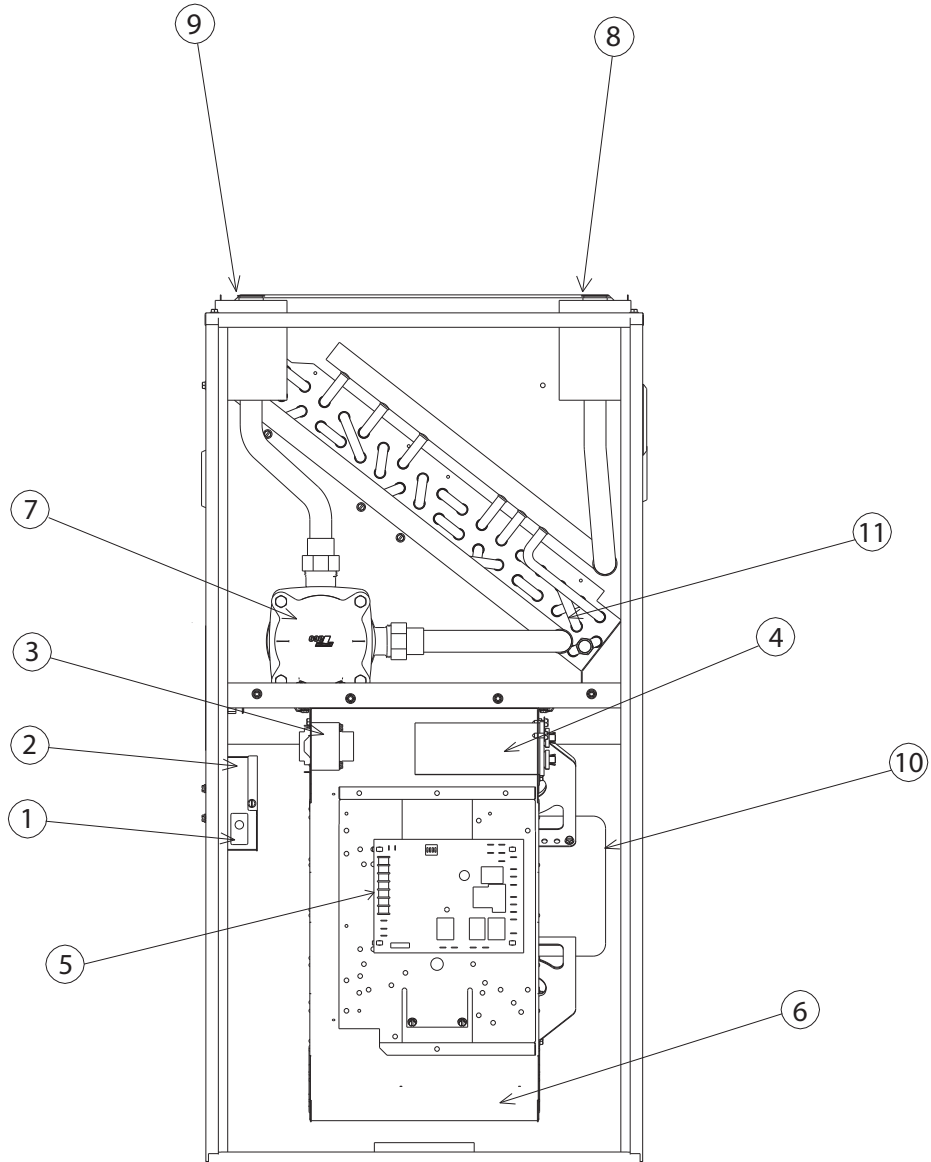

ITEM NO.	PART NAME	ITEM NO.	PART NAME
1	DOOR SWITCH	7	PUMP
2	JUNCTION BOX	8	WATER INLET
3	TRANSFORMER	9	WATER OUTLET
4	CAPACITOR	10	BLOWER MOTOR
5	LOW VOLTAGE (THERMOSTAT) TERMINAL	11	HYDRONIC COIL ASSEMBLY
6	BLOWER		

## IMPORTANT INFORMATION ABOUT EFFICIENCY AND INDOOR AIR QUALITY

Central cooling and heating equipment is only as efficient as the duct system that carries the cooled or heated air. To maintain efficiency, comfort and good indoor air quality, it is important to have the proper balance between the air being supplied to each room and the air returning to the cooling and heating equipment.

Proper balance and sealing of the duct system improves the efficiency of the heating and air conditioning system and improves the indoor air quality of the home by reducing the amount of airborne pollutants that enter homes from spaces where the ductwork and/or equipment is located. The manufacturer and the U.S. Environmental Protection Agency's ENERGY STAR Program recommend that central duct systems be checked by a qualified contractor for proper balance and sealing.

### **▲ WARNING**

**DUCT LEAKS CAN CREATE AN UNBALANCED SYSTEM AND DRAW POLLUTANTS SUCH AS DIRT, DUST, FUMES AND ODORS INTO THE HOME CAUSING PROPERTY DAMAGE. FUMES AND ODORS FROM TOXIC, VOLATILE OR FLAMMABLE CHEMICALS, AS WELL AS AUTOMOBILE EXHAUST AND CARBON MONOXIDE (CO), CAN BE DRAWN INTO THE LIVING SPACE THROUGH LEAKING DUCTS AND UNBALANCED DUCT SYSTEMS CAUSING PERSONAL INJURY OR DEATH (SEE FIGURE 2).**

- IF AIR-MOVING EQUIPMENT OR DUCTWORK IS LOCATED IN GARAGES OR OFF-GARAGE STORAGE AREAS - ALL JOINTS, SEAMS, AND OPENINGS IN THE EQUIPMENT AND DUCT MUST BE SEALED TO LIMIT THE MIGRATION OF TOXIC FUMES AND ODORS INCLUDING CARBON MONOXIDE FROM MIGRATING INTO THE LIVING SPACE.
- IF AIR-MOVING EQUIPMENT OR DUCTWORK IS LOCATED IN SPACES CONTAINING FUEL BURNING APPLIANCES SUCH AS WATER HEATERS OR BOILERS - ALL JOINTS, SEAMS, AND OPENINGS IN THE EQUIPMENT AND DUCT MUST ALSO BE SEALED TO PREVENT DEPRESSURIZATION OF THE SPACE AND POSSIBLE MIGRATION OF COMBUSTION BYPRODUCTS INCLUDING CARBON MONOXIDE INTO THE LIVING SPACE.

### NOTICE

**IMPROPER INSTALLATION, OR INSTALLATION NOT MADE IN ACCORDANCE WITH THE UL CERTIFICATION OR THESE INSTRUCTIONS, CAN RESULT IN UNSATISFACTORY OPERATION AND/OR DANGEROUS CONDITIONS AND ARE NOT COVERED BY THE UNIT WARRANTY.**

### NOTICE

**IN COMPLIANCE WITH RECOGNIZED CODES, IT IS RECOMMENDED THAT AN AUXILIARY DRAIN PAN BE INSTALLED UNDER ALL EVAPORATOR COILS OR UNITS CONTAINING EVAPORATOR COILS OR AIR HANDLERS USED WITH EVAPORATOR COILS THAT ARE LOCATED IN ANY AREA OF A STRUCTURE DAMAGE TO THE BUILDING OR BUILDING CONTENTS MAY OCCUR AS A RESULT OF AN OVERFLOW OF THE COIL DRAIN PAN OR A STOPPAGE IN THE PRIMARY CONDENSATE DRAIN PIPING.**

required for the job specification.

- Read the entire instructions before starting the installation.
- Some building codes require extra cabinet insulation and gasketing when unit is installed in attic applications.
- If installed in an unconditioned space, apply caulking around the power wires, control wires, refrigerant tubing and condensate line where they enter the cabinet. Seal the power wires on the inside where they exit conduit opening. Caulking is required to prevent air leakage into and condensate from forming inside the unit, control box, and on electrical controls.
- Install the unit in such a way as to allow necessary access to the coil/pump and blower/control compartment.
- Install the unit in a level position to ensure proper condensate drainage. Make sure unit is level in both directions within 1/8".
- Install the unit in accordance with any local code which may apply and the national codes. Latest editions are available from: "National Fire Protection

**FIGURE 2**  
MIGRATION OF DANGEROUS SUBSTANCES, FUMES, AND ODORS INTO LIVING SPACES

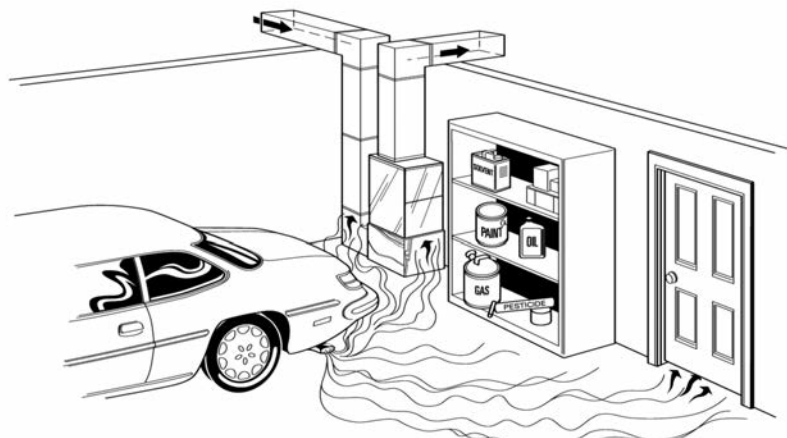

Adapted from *Residential Duct Diagnostics and Repair*, with permission of Air Conditioning Contractors of America (ACCA).

## RECEIVING

Immediately upon receipt, all cartons and contents should be inspected for transit damage. Units with damaged cartons should be opened immediately. If damage is found, it should be noted on the delivery papers, and a damage claim filed with the last carrier.

- After unit has been delivered to job site, remove carton, taking care not to damage unit.
- Check the unit rating plate for unit size, voltage, phase, etc. to be sure equipment matches what is

Association, Inc., Batterymarch Park, Quincy, MA 02269." These publications are:

- ANSI/NFPA No. 70-(Latest Edition) National Electrical Code.
- NFPA90A Installation of Air Conditioning and Ventilating Systems.
- NFPA90B Installation of Warm Air Heating and Air Conditioning Systems.
- The equipment has been evaluated in accordance with the Code of Federal Regulations, Chapter XX, Part 3280.

# LOCATION REQUIREMENTS AND CONSIDERATIONS

## GENERAL INFORMATION

1. **IMPORTANT:** If installing the unit over a finished ceiling or living area, be certain to install an auxiliary condensate drain pan under the entire unit. This auxiliary drain pan should extend under any evaporator coil installed with the air handler and the open portion of the condensate drain assembly.
2. **IMPORTANT:** If using a cooling evaporator coil with this air handler:  
Be sure the air passes over the coil/pump before passing over the cooling coil.

**IMPORTANT:** Support this unit when installed. Since this air handler is suitable for attic or crawl space installations, it may be installed on combustible wood flooring or by using support brackets.

5. **IMPORTANT: If installing in a utility room, be sure the door is wide enough to:**
  - a. allow the largest part of the air handler to pass; or
  - b. allow any other appliance (such as a water heater) to pass.
6. **IMPORTANT:** This air handler is not approved or recommended for installation on its back, with access doors facing upwards (see Figure 3).

## CLEARANCE - ACCESSIBILITY

The design of air handlers with input ratings as listed in the tables under Figure 4 are certified by UL for the clearances to combustible materials shown in inches.

See name/rating plate and clearance label for specific model number and clearance information.

Service clearance of at least 24" is recommended in front of all air handlers.

**NOTE:** Use recommended 24" clearance if accessibility clearances are greater than fire protection clearances.

**Air handlers are shipped with a bottom closure panel installed. When bottom return air is used, remove the panel by removing the two screws attaching the panel to the front base angle.**

## SITE SELECTION

1. Select a site in the building near the center of the proposed, or existing, duct system.
2. Locate the air handler to maintain proper clearance to combustibles as shown in the following tables.

**FIGURE 3**

### PROHIBITED INSTALLATIONS

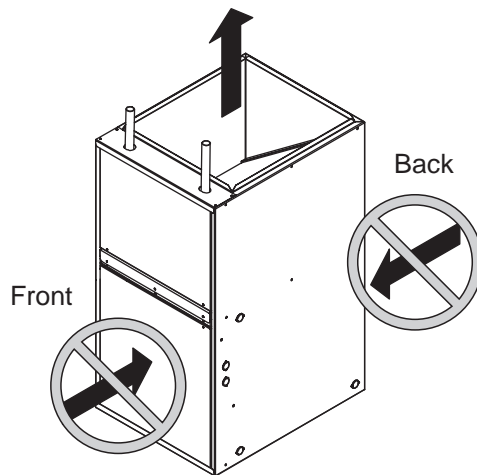

The air inlet is not allowed to be at the front or back of the air handler.

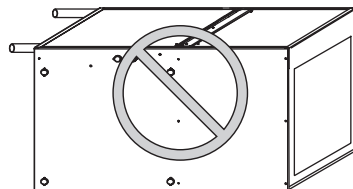

Do not position the air handler on its back or with it face down. Do not cut sides of horizontal application.

**NOTE:**

Multiple air handlers configured for installation with a single Tankless Water Heater is prohibited.

**FIGURE 4**  
**CLEARANCE TO COMBUSTIBLES, UPFLOW, HORIZONTAL LEFT OR RIGHT,**  
**NO DOWNFLOW**

**IMPORTANT:** Support this unit when installed. Since this air handler is suitable for attic or crawl space installation, it may be installed on combustible wood flooring or by using support brackets.

MODEL	MINIMUM CLEARANCE (IN.)					
	A	B	C	D	E	F
04	17 1/2	16 1/32	15%	3/4 ID	15	13 25/32
06	17 1/2	16 1/32	15%	3/4 ID	15	13 25/32
08	24 1/2	23 1/32	22%	3/4 ID	22	20 25/32
10	24 1/2	23 1/32	22%	3/4 ID	22	20 25/32

\*A service clearance of at least 24 inches is recommended in front of all air handlers.

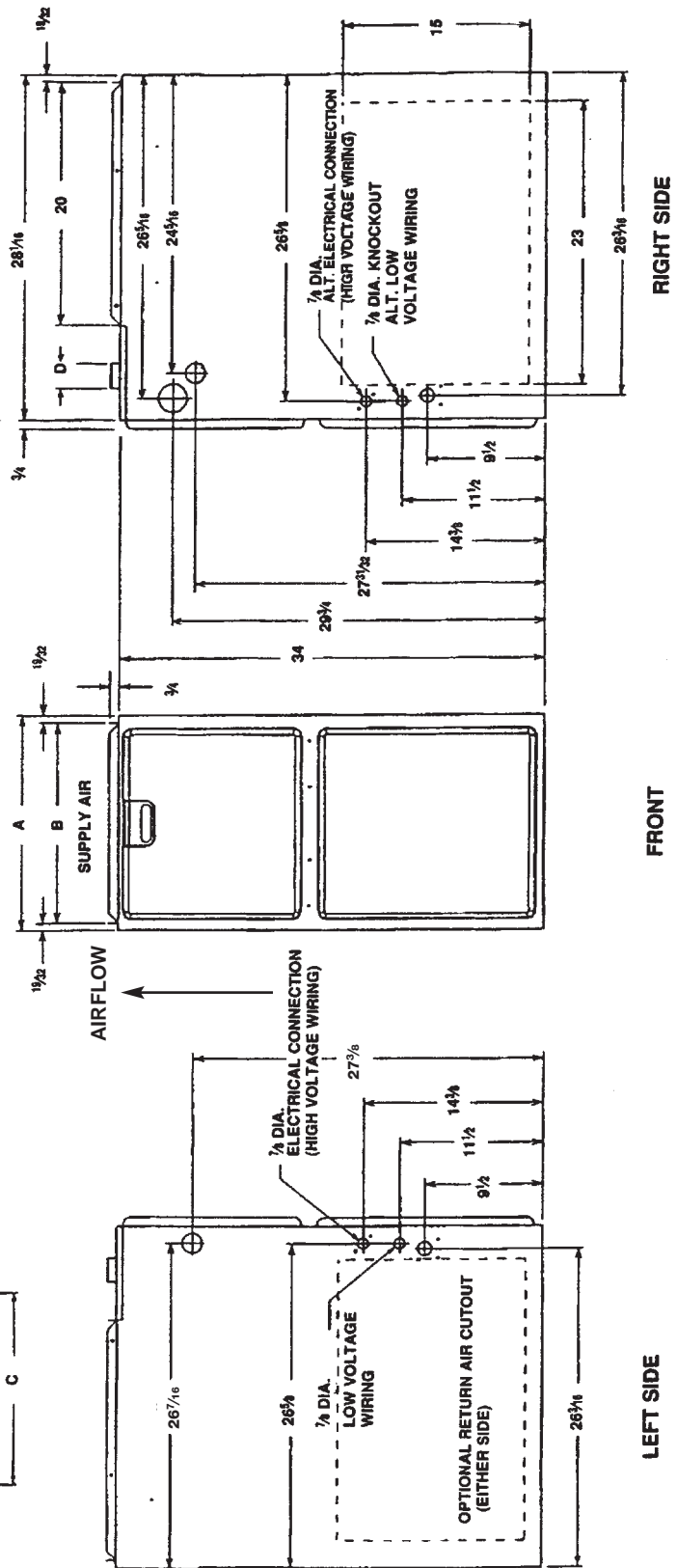
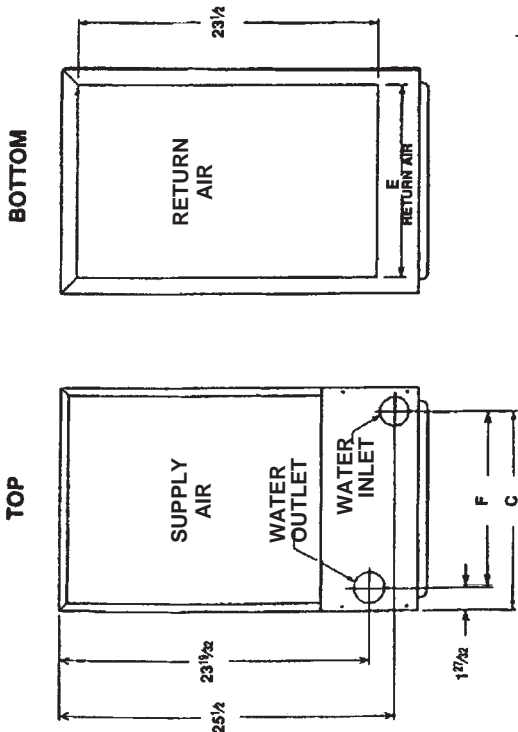

## SELECTION PROCEDURE (WITH EXAMPLE)

### I. Define hot water load for the total required domestic hot water usage.

As an example, let's assume that the selected Tankless Water Heater for your whole house solution is the RTG-74 and your calculated heat gain and heat loss values are as stated in section II.

### II. Determine cooling and heating requirements at design conditions:

The ACCA's Manual J Residential Load Calculation method is the established trade standard, approved by ANSI, for the correct sizing and selection of Heating, Ventilation, Air-Conditioning and Refrigeration (HVACR) equipment in residential homes. The most recent revision is the eight edition, an all-inclusive new approach to ensuring that Indoor Air Quality (IAQ) systems are as efficient, safe, and healthy as possible. Refer to the Air Conditioning Contractors of America website at: <http://www.acca.org/tech/manualj/> or a qualified HVACR contractor for further assistance.

#### Assumptions:

Required Cooling Capacity . . . 48,000 BTU/HR  
(Total Capacity)  
Required Heating Capacity . . . 60,000 BTU/HR  
Evaporator Air Quantity . . . . . 1600 CFM  
External Static Pressure . . . . . 0.2 in. W.C.  
Electrical Characteristics . . . . . 115-1-60

### III. Determine total external static pressure (ESP) at design conditions:

Before using the Airflow Performance Table calculate the total static pressure required. From the given example, note the Wet Coil Pressure Drop (selected from the field supplied Evaporative Cased Coil Installation Instructions), and the Filter Pressure Drop. Determine both static pressures at 1600 CFM:

Wet Coil Pressure Drop . . . .0.3 in. W.C.  
(From Coil Manufacturer's Installation Instructions)  
External Static Pressure . . . 0.2 in. W.C.  
(Ductwork, etc.)

Filter Pressure Drop . . . .08 in. W.C.  
(.08 inches if the included filter is used; refer to the filter's manufacturer's instructions if another filter is used.)

Total Static Pressure . . . 0.58 in. W.C.

### IV. Select unit based on required cooling capacity airflow:

For an initial selection, choose a unit size that will provide the required airflow. Refer to Airflow Performance Table. Note that at 0.6 ESP (external static pressure) the RHWB-06WMP48A unit will deliver 1560 CFM when configured for HIGH speed.

### V. Select heating capacity of unit to provide the requisite design condition:

From the Hydronic Air Handler/Tankless Water Heater, note that the unit RHWB-06WMP48A, (as selected above) when matched with the RTG-95 Tankless Water Heater, will provide 59.2 MBH (59,200 BTU/HR) at an input water temperature (to Air Handler) of 150°F.

## Model Number Nomenclature

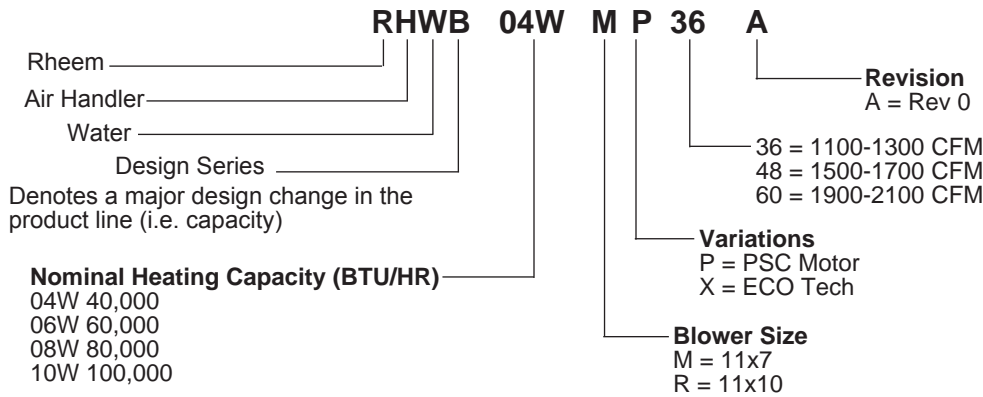

## HYDRONIC AIR HANDLER MODEL IDENTIFICATION

R	H	W	B	-06W		M	P	36	A
Brand	Application	Type	Design Series	Heating Output Designation		Blower Size	Variations	Heat/Cool Designation	Revision
				Inlet Water Temp = 150°F [66°C]	Output BTU/HR [kW]				
R = Rheem	H = Air handler	W = Water	B = 2nd Series	04W	40,000 [11.7 kW]	M = 11x7 [279 x 178 mm] R = 11x10 [279 x 254 mm]	P = PSC X = ECO TECH™	36 = 1100-1300 CFM [519-613.5 L/s] 48 = 1500-1700 CFM [707.9-802.3 L/s] 60 = 1900-2100 CFM [896.7-991.1 L/s]	A - Rev 0
				06W	60,000 [17.6 kW]				
				08W	80,000 [23.5 kW]				
				10W	90,000 [28.3 kW]				



# HYDRONIC AIR HANDLER ELECTRICAL PHYSICAL SPECIFICATIONS - PSC MODELS

## U.S. and Canadian Models

MODEL NUMBERS	RHWP-04WMP36A	RHWP-06WMP48A	RHWP-08WRP60A	RHWP-10WRP60A
Nominal Heating Capacity BTU/hr [W]	40000	60000	80000	100000
Air Side Temperature Rise* °F [°C]	45-75 [25-41.7]	40-70 [22.2-38.9]	35-65 [19.4-36.1]	35-65 [19.4-36.1]
Heating CFM [L/s] @ .8 WC [.19 kPa]	590 [278]	1000 [471]	1453 [685]	1818 [858]
Cooling CFM [L/s] @ .5 WC [.12 kPa]	1235 [582]	1622 [765]	1871 [883]	1973 [931]
Power Supply (V - HZ - PH)	115 - 60 - 1			
Minimum Circuit Ampacity - Amps	9.6	10.9	13.6	13.6
Max Rating of Over Current Protective Device - Amps	15.8	18.2	23	23
Maximum Fuse or Circuit Breaker Size	15	15	20	20
Motor HP [W]	1/2 [373]	3/4 [559]	3/4 [559]	3/4 [559]
Blower (D x W) in [mm]	11 x 7 [279 x 178]	11 x 7 [279 x 178]	11 x 10 [279 x 254]	11 x 10 [279 x 254]
Blower Motor Type	PSC			
Pump Type	Wet Rotor			
Pump Power Supply (V - HZ - PH)	115 - 60 - 1			
Pump Motor RLA/LRA - Amps	1.8			
Pump HP [W]	1/8			
Pump Maximum Working Pressure psi [kPa]	125 [861]			
Min/Max Working Temperature °F [°C]	160 [71]			
Water Connection Type	Copper Studs			
Inlet Water Connection Diameter in [mm]	3/4 [19]			
Out Water Connection Diameter in [mm]	3/4 [19]			
Return Air Filter Size in [mm]	12 x 16 [305 x 406]		16 x 24 [406 x 609]	
Standard High Velocity Filter Size (L x W x H) in [mm]	15 3/4 x 25 x 1 [400 x 635 x 25]		22 3/4 x 25 x 1 [578 x 635 x 25]	
Shipping Weight LBS [kg]	107 [48.5]	118 [53.5]	137 [62.1]	145 [65.7]

# HYDRONIC AIR HANDLER ELECTRICAL PHYSICAL SPECIFICATIONS - ECO-TECH™ MODELS

## U.S. and Canadian Models

MODEL NUMBERS	RHWP-04WMX36A	RHWP-06WMXP48A	RHWP-08WRX60A	RHWP-10WRX60A
Nominal Heating Capacity BTU/hr [W]	40000	60000	80000	100000
Air Side Temperature Rise* °F [°C]	45-75 [25-41.7]	40-70 [22.2-38.9]	35-65 [19.4-36.1]	35-65 [19.4-36.1]
Heating CFM [L/s] @ .8 WC [.19 kPa]	578 [272]	1030 [485]	1502 [707]	1847 [870]
Cooling CFM [L/s] @ .5 WC [.12 kPa]	1180 [556]	1300 [612]	1645 [775]	1707 [804]
Power Supply (V - HZ - PH)	115 - 60 - 1			
Minimum Circuit Ampacity - Amps	9.6	12.4	12.4	12.4
Max Rating of Over Current Protective Device - Amps	15.8	20.9	20.9	20.9
Maximum Fuse or Circuit Breaker Size	15	20	20	20
Motor HP [W]	1/2 [373]	3/4 [559]	3/4 [559]	3/4 [559]
Blower (D x W) in [mm]	11 x 7 [279 x 178]	11 x 7 [279 x 178]	11 x 10 [279 x 254]	11 x 10 [279 x 254]
Blower Motor Type	EcoTech / ECM Type			
Pump Type	Wet Rotor			
Pump Power Supply (V - HZ - PH)	115 - 60 - 1			
Pump Motor RLA/LRA - Amps	1.8			
Pump HP [W]	1/8			
Pump Maximum Working Pressure psi [kPa]	125 [861]			
Min/Max Working Temperature °F [°C]	160 [71]			
Water Connection Type	Copper Studs			
Inlet Water Connection Diameter in [mm]	3/4 [19]			
Out Water Connection Diameter in [mm]	3/4 [19]			
Return Air Filter Size in [mm]	12 x 16 [305 x 406]		16 x 24 [406 x 609]	
Standard High Velocity Filter Size (L x W x H) in [mm]	15 3/4 x 25 x 1 [400 x 635 x 25]		22 3/4 x 25 x 1 [578 x 635 x 25]	
Shipping Weight LBS [kg]	116 [52.6]	126 [57.2]	146 [66.2]	153 [69.3]

# SAMPLE HYDRONIC AIR HANDLER PERFORMANCE

SAMPLE HYDRONIC AIR HANDLER PERFORMANCE									
	WATER INLET TEMP (°F) [°C]	WATER OUTLET TEMP (°F) [°C]	WATER FLOW		AIR INLET TEMP (°F) [°C]	AIR OUTLET TEMP (°F) [°C]	AIR CFM [L/s]	CAPACITY (BTU/HR) [kW]	AIR TEMP RISE (°F) [°C]
			LB/HR	GPM					
RHWB-04WMP36A RHWB-04WMX36A	120 [49]	110 [43]	[kg/hr]		68 [20]	106 [41]	646 [305]	20900 [6.13]	30 [17]
	130 [54]	117 [47]				113 [45]		25800 [7.56]	37 [21]
	140 [60]	125 [52]	2000/ [907]	4		122 [50]		29800 [8.73]	43 [24]
	150* [66]	132 [56]				130 [54]		35000 [10.26]	50 [28]
	160 [71]	140 [60]				137 [58]		40000 [11.72]	57 [32]
RHWB-06WMP48A RHWB-06WMX48A	120 [49]	100 [38]	2000/ [907]	4	68 [20]	105 [41]	1000 [462]	38200 [11.20]	31 [17]
	130 [54]	108 [42]				109 [43]		44900 [13.16]	37 [21]
	140 [60]	115 [46]				116 [47]		50600 [14.83]	42 [23]
	150 [66]	120 [49]				126 [52]		60000 [17.58]	49 [27]
	160 [71]	126 [52]				129 [54]		67100 [19.67]	55 [31]
RHWB-08WRP60A RHWB-08WRX60A	120 [49]	106 [36]	2000/ [907]	4	68 [20]	103 [39]	1450 [684]	45500 [13.33]	26 [14]
	130 [54]	113 [39]				108 [42]		53700 [15.74]	31 [17]
	140 [60]	121 [43]				113 [45]		62500 [18.32]	36 [20]
	150 [66]	128 [46]				120 [49]		71800 [21.04]	42 [23]
	160 [71]	135 [49]				123 [51]		80500 [23.59]	47 [26]
RHWB-10WRP60A RHWB-10WRX60A	120 [49]	96 [36]	2000/ [907]	4	68 [20]	100 [38]	1800 [850]	47200 [13.83]	27 [15]
	130 [54]	101 [38]				110 [43]		57800 [16.94]	33 [18]
	140 [60]	106 [41]				112 [44]		66900 [19.61]	38 [21]
	150 [66]	111 [44]				119 [48]		77000 [22.57]	44 [24]
	160 [71]	106 [46]				124 [51]		86800 [25.44]	50 [28]

CFM - Cubic Feet Per Minute

Performance is based on the following assumptions:

- 1) an estimated 100 ft. [30m] equivalent length of 0.75-inch piping
- 2) 0.50" [13] w.c. of external air static.

# HYDRONIC AIR HANDLER TANKLESS WATER HEATER PERFORMANCE

Air Handler Model	Tankless Model	Blower Speed	ESP (In. W.C.)	Heating Air Delivery (CFM) [L/s]	Capacity (BTU/HR) [kW]				
					Entering Water Temperature (°F) (°C)				
					120 [49]	130 [54]	140 [60]	150* [65]	160 [71]
RHWB-04WMP36A RHWB-04WMX36A	RTG-64	High	0.5 [124.5]	1235 [583]	26400 [7.74]	31800 [9.32]	35500 [10.40]	N/A	N/A
	RTG-84				25700 [7.53]	30900 [9.06]	33900 [9.94]	39600 [11.61]	44800 [13.13]
	RTG-95				25600 [7.50]	31500 [9.23]	34600 [10.14]	40000 [11.72]	45400 [13.31]
	RTGH-84				27700 [8.12]	30100 [8.82]	35400 [10.37]	40600 [11.90]	46000 [13.48]
	RTGH-95				25400 [7.44]	30200 [8.85]	32700 [9.58]	40200 [11.78]	45400 [13.31]
RHWB-06WMP48A RHWB-06WMX48A	RTG-53	High	0.5 [124.5]	1622 [765]	32600 [9.55]	39500 [11.58]	47500 [13.92]	N/A	N/A
	RTG-64				40900 [11.99]	47100 [13.80]	51000 [14.95]	N/A	N/A
	RTG-66				40200 [11.78]	46400 [13.60]	54700 [16.03]	63500 [18.61]	71300 [20.90]
	RTG-74				37700 [11.05]	46200 [13.54]	54000 [15.83]	62700 [18.38]	71300 [20.90]
	RTG-84				40000 [11.72]	47800 [14.01]	52100 [15.27]	60300 [17.67]	68100 [19.96]
	RTG-95				37200 [10.90]	45200 [13.25]	50900 [14.92]	59200 [17.35]	66400 [19.46]
	RTGH-84				38600 [11.31]	44300 [12.98]	49000 [14.36]	55300 [16.21]	62000 [18.17]
	RTGH-95				33900 [9.94]	43300 [12.69]	53800 [15.77]	60600 [17.76]	69500 [20.37]
RHWB-08WRP60A RHWB-08WRX60A	RTG-53	Med-High	0.5 [124.5]	1586 [749]	35000 [10.26]	41300 [12.10]	50600 [14.83]	N/A	N/A
	RTG-64				42000 [12.31]	50900 [14.92]	53400 [15.65]	N/A	N/A
	RTG-66				40400 [11.84]	50500 [14.80]	56500 [16.56]	65500 [19.20]	73600 [21.57]
	RTG-74				40300 [11.81]	49700 [14.57]	58800 [17.23]	71600 [20.98]	81600 [23.91]
	RTG-84				45800 [13.42]	53300 [15.62]	56900 [16.68]	66900 [19.61]	76000 [22.27]
	RTG-95				45300 [13.28]	53100 [15.56]	60000 [17.58]	70500 [20.66]	80700 [23.65]
	RTGH-84				45900 [13.45]	54900 [16.09]	59000 [17.29]	67500 [19.78]	75900 [22.24]
	RTGH-95				44900 [13.16]	52700 [15.44]	58300 [17.09]	65200 [19.11]	73100 [21.42]
RHWB-10WRP60A RHWB-10WRX60A	RTG-53	Med-High	0.5 [124.5]	1620 [765]	35500 [10.40]	44500 [13.04]	53300 [15.62]	N/A	N/A
	RTG-64				40800 [11.96]	48000 [14.07]	53200 [15.59]	N/A	N/A
	RTG-66				48300 [14.16]	57800 [16.94]	62100 [18.20]	71800 [21.04]	83000 [24.32]
	RTG-74				49300 [14.45]	59600 [17.47]	69500 [20.37]	79100 [23.18]	89700 [26.29]
	RTG-84				43200 [12.66]	51800 [15.18]	56900 [16.68]	65100 [19.08]	75400 [22.10]
	RTG-95				48300 [14.16]	58200 [17.06]	61000 [17.88]	71000 [20.81]	79800 [23.39]
	RTGH-84				44600 [13.07]	53000 [15.53]	56000 [16.41]	65400 [19.17]	74400 [21.80]
	RTGH-95				44600 [13.07]	52000 [15.24]	56500 [16.56]	65400 [19.17]	75500 [22.12]

CFM = Cubic Feet Per Minute

ESP = External Static Pressure

\* Recommended Operating Point

Inlet Air at 72°F [22°C]

Capacities are based on a piping arrangement with a total equivalent length of 100 ft [30m].

Entering water temperatures must not exceed 160°F [71°C]

## DUCTING

Proper air flow is required for the correct operation of this air handler. Too little air flow can cause erratic operation and can damage the heat exchanger. The duct system must carry the correct amount of air for heating and cooling if summer air conditioning is used.

Size the ducts according to acceptable industry standards and methods. The total static pressure drop of the air distribution system should not exceed 0.8" w.c.

**NOTE:** Return air grilles and warm air registers must not be obstructed

**IMPORTANT:** Some high efficiency filters have a greater than normal resistance to air flow. This can adversely affect air handler operation. **BE SURE TO CHECK AIR FLOW.**

**IMPORTANT:** When using outside air, design and adjust the system to maintain a return air temperature ABOVE 50° F during the heating season.

## UPFLOW UNITS

1. Position the unit to minimize long runs of duct or runs of duct with many turns and elbows.
2. Open the return air compartment.
  - a. Cut an opening in the side. The opening should be cut the full width of the knockouts on the unit. See Figure 5.

**NOTE:** Where the maximum air flow is 1800 CFM or more, both sides or the bottom must be used for return air.

3. Connect the return duct or return air cabinet to the unit. Make the connection air tight to prevent entraining combustion gases from an adjacent fuel-burning appliance.

4. **Be sure to have adequate space for the unit filter.**

**NOTE:** DO NOT take return air from bathrooms, kitchens, air handler rooms, garages, utility or laundry rooms, or cold areas.

**NOTE:** DO NOT use a rear air return.

5. If summer air conditioning (heat pump) is desired, position the indoor coil on the top of the unit. Insure that no air can bypass this coil.
6. Connect the supply air plenum to the air handler plenum opening.

## HORIZONTAL UNIT

1. Position the unit to minimize long runs or runs with many turns and elbows.
2. If summer air conditioning or heat pump is desired, position the indoor coil on the supply air end of the unit. Insure that no air can bypass this coil.
3. Connect the air handler to the supply air plenum.
4. Connect the return air ducting to the return air opening of the unit. Make the connection air tight to prevent pulling combustion gases from an adjacent fuel-burning appliance.
5. **Be sure to have adequate space for the unit filter.**

**NOTE:** DO NOT take return air from bathrooms, kitchens, air handler rooms, garages, utility or laundry rooms, or cold areas.

## DOWNFLOW UNITS

1. Position the unit to minimize long runs of duct or runs of duct with many turns and elbows.
2. If summer air conditioning is desired, position the indoor coil on the supply air side of the unit. Insure that no air can bypass this coil.
3. Connect the furnace to the supply air plenum.
4. Connect the return air ducting to the return air opening at the top of the unit. Make the connection air tight to prevent entraining combustion gases from an adjacent fuel-burning appliance.
5. Be sure to have adequate space for the unit filter.

**NOTE:** DO NOT take return air from bathrooms, kitchens, furnace rooms, garages, utility or laundry rooms, or cold areas.

**FIGURE 5**  
CUTOUT AND DRILL INFORMATION  
UPFLOW ONLY

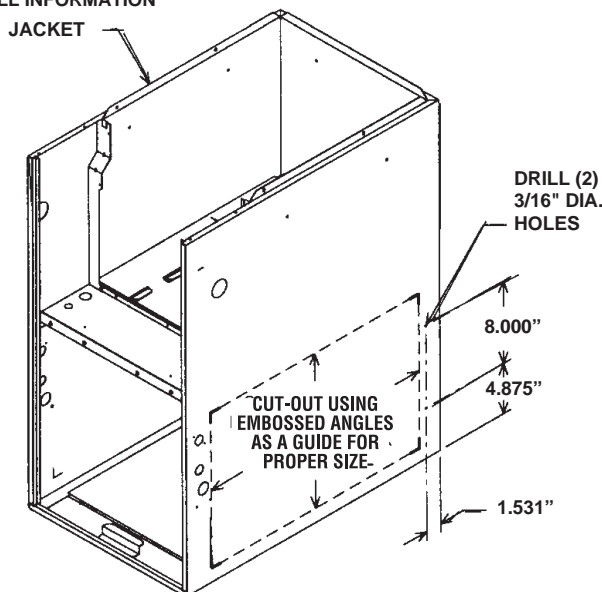

\*Solid metal bottom required if side duct penetration is used.

**FIGURE 6**  
**POSITION ORIENTATION**

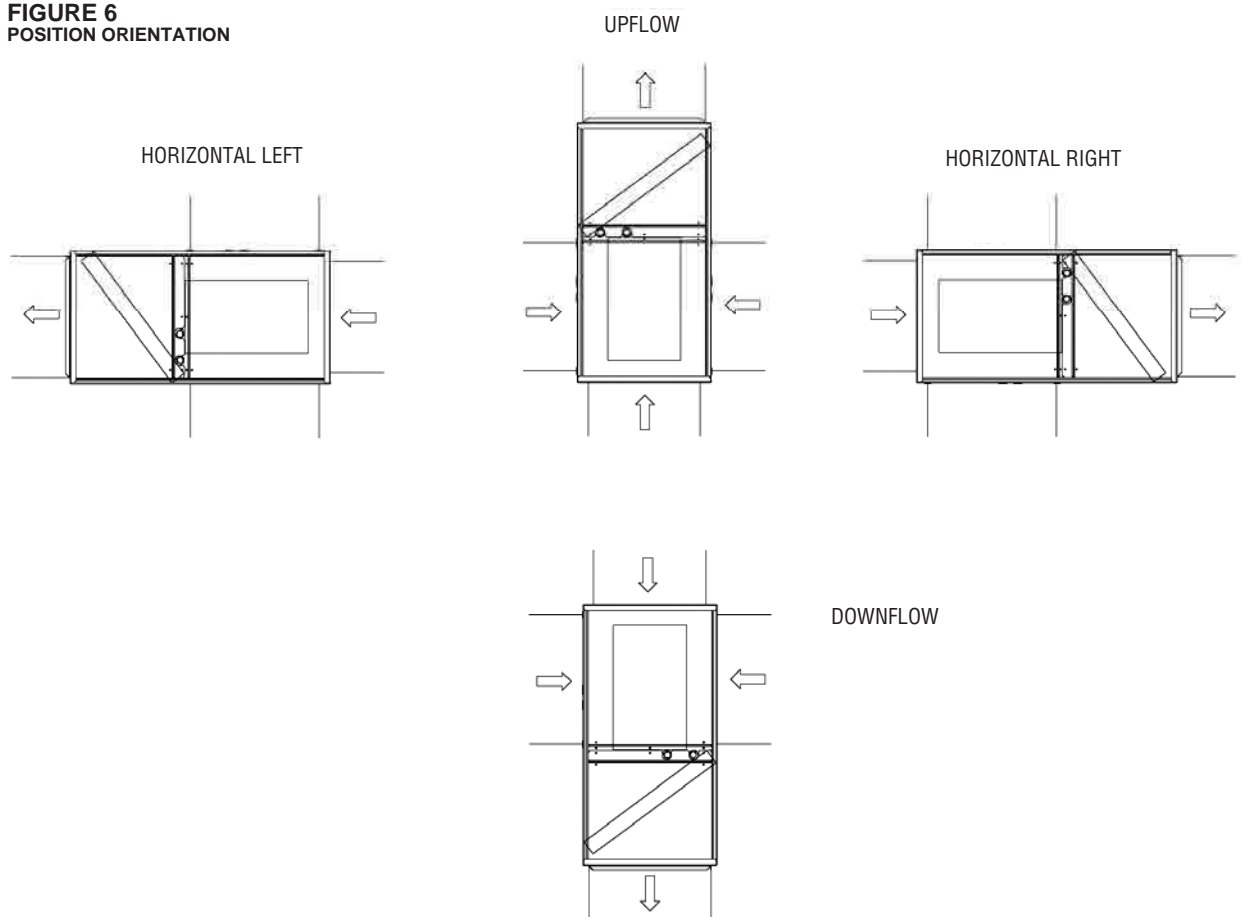

# INSTALLATION

## SUSPENDED CABINET INSTALLATION

If the cabinet cannot be supported on a frame or supported from the wall, it may be suspended.

Use metal strapping or threaded rod with angle iron supports under cabinet for support. These supports MUST run parallel with the length of the cabinet.

Ensure that there is adequate room to remove service and access panels after installing supporting brackets.

If an auxiliary drain pan is required, the support is to be placed under a drain pan.

### ▲ WARNING

**IT IS THE INSTALLER'S RESPONSIBILITY TO USE AN APPROPRIATE HANGING METHOD CAPABLE OF SUPPORTING THE UNIT'S WEIGHT. REFER TO THE SPECIFICATION SECTION OF THIS DOCUMENT FOR THE RESPECTIVE UNIT'S INSTALLED WEIGHTS.**

### NOTICE

**FOR SEISMIC HANGING REQUIREMENTS, REFER TO LOCAL CODES.**

### Attachment Methods Using Straps

#### Method 1

Use (4) #8 x 3/4 sheet metal screws for each strap. The straps should be vertical against the air handler sides and not pull away from the air handler sides.

#### Method 2

Fold all straps under the air handler and secure with (4) #8 x 3/4 sheet metal screws (2 screws at the side and 2 screws at the bottom. (Care must be taken not to drive the screw through the coil.)

**FIGURE 7  
HORIZONTAL UNIT SUSPENSION**

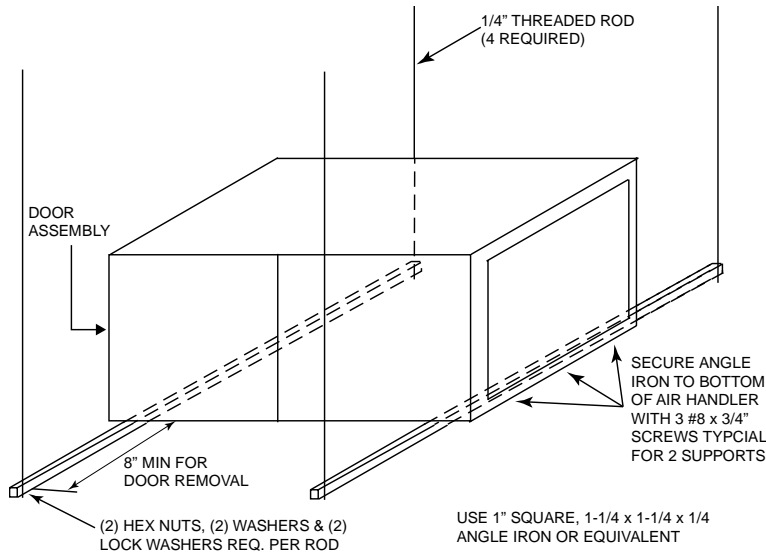

**FIGURE 8  
HORIZONTAL UNIT SUSPENSION WITH STRAPS**

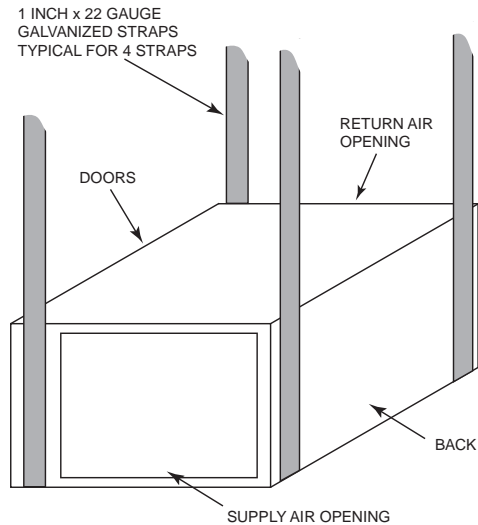

## PLUMBING

### Codes:

The RHWB air handler is used in potable water systems. Therefore, it is important to observe all local sanitary codes when installing water lines. The water supply mating connection to the Hydronic Air Handler is made via the two (3/4 in. dia. X 2-1/2 in. long) copper stubs to the front-left of the unit labeled "WATER IN" and "WATER OUT" (see Figure 1). Mating connectors to be two field-supplied, 3/4 in., FNPT-sweat ends or equivalent.

All associated hydronic piping MUST comply with ICC, UPC and any other local codes or ordinances having jurisdiction. USE POTABLE GRADE COPPER PIPING AND BRASS APPURTENANCES ONLY.

### Flow Switch Installation:

(Recommended for Open-Loop Systems)

Care must be taken to ensure that the flow switch is not damaged due to excessive tightening. The torque must not exceed the maximum limit stated below. The installation should be checked to ensure that no leaking is evident.

Mating connectors to be (2) 3/4" FNPT fittings (field supplied).

Pipe-work/connector alignment is imperative (avoid bending stress).

Polytetrafluoroethylene (PTFE) thread seal tape (teflo tape), or equivalent, is recommended.

Tighten fittings to maximum torque of 15lb/ft (20Nm).

The pressure flow switch should be installed in a straight horizontal section of pipe at least 4" from elbows.

### Soldering Copper Tubing:

The common method of joining copper tubing in hydronic heating systems is soft soldering. Plumbing codes do not allow solders containing lead to be used for domestic water service. USE ONLY 95/5 tin/antimony solder for all piping systems that incorporate a domestic water supply.

**NOTE:** Precautions must be taken during soldering to avoid debris or solder from lodging in piping system.

### Water Storage Tank:

When connecting directly to a water storage tank it is necessary to ensure the water flow rate does not become excessive. Excessive water flow can result in increased system noise and potential system damage. In order to regulate the flow it is required that an adjustable valve be placed between the air handler outlet and the storage tank.

Furthermore, two pressure taps will need to be installed, the first located between the air handler outlet and the adjustable valve as near as possible to the outlet, and the second on the inlet water attached as near as possible to the inlet. While the water pump is engaged the adjustable valve will be closed until the pressure difference between the outlet and the inlet is greater than 13.5 PSID.

### Tubing Insulation:

Any tube-conveying fluid at a temperature greater than that of the surrounding air releases heat.

Insulate all accessible hot water lines and associated valves with material, such as expanded neoprene or polyurethane 3/8-in. to 1/2-in. thick.

Match the pipe sleeve's inside diameter to the pipe's outside diameter for a snug fit. Place the pipe sleeve so the seam will be face down on the pipe. Tape, wire, or clamp insulation every foot or two to secure it to the pipe. If taping is desired, use acrylic tape instead of duct tape.

### Copper Tubing Support:

Copper tubing must be properly supported to prevent sagging or buckling. On horizontal runs with hard temper tubing, the following maximum support spacing is suggested:

- 1/2 in. to 3/4 in. tube: 5 feet maximum spacing
- 1 in. to 1-1/4 in. tube: 6 feet maximum spacing

The above suggested spacing does not account for extra weight of piping components such as an expansion tank, etc. When such components are present, the piping should be supported immediately adjacent to the component.

On vertical runs, copper tubing should be supported at each floor level or at a maximum of every 10 feet.

### Thermal Expansion of Piping:

In all hydronic systems, piping undergoes temperature swings as the system operates. This causes changes in the length of the piping due to thermal expansion.

If the piping is rigidly mounted, this expansion can cause annoying popping or squeaking sounds and, in extreme cases, the piping can even buckle.

To counter expansion movement, design piping circuits with sufficient elbows, tees or expansion loops (only used in large systems) or piping supports that allow the tubing to expand and contract freely.

Another alternative is to install an expansion compensator fitting capable of absorbing the movement.

### Hydronic Resistance of Fittings, Valves, and Other Devices:

Before the total hydronic resistance of a piping circuit can be found, the individual hydronic resistances of all fittings, valves, or other such components must be determined. One approach is to consider each fitting, valve, or other device as an equivalent length of copper tube of the same pipe size (see Table 2).

By using the equivalent length of piping for all components in the circuit, the circuit can be treated as if it were a single piece of pipe having a length equal to the sum of the actual pipe length, the total equivalent lengths of all fittings, valves, or other devices. Refer to Figure 9 and the calculation of equivalent lengths.

### Pipe Sizing Considerations:

When selecting a pipe size for a given flow rate, the resulting average flow velocity should be between 2 and 4 feet per second.

At water flow velocities of approximately 2 feet per second, flowing water will carry air bubbles along a vertical pipe. Average flow velocities of 2 feet per second or higher can draw along air bubbles in a downward flow. At the above stated velocities air bubbles shall be routed to an air separator where they can be collected and discharged from the system. Use Taco 4900 series air separator, Model 49-075, or equivalent (field supplied).

Average flow velocities higher than 4 feet per second could cause flow noise and should be avoided.

### Expansion Tank:

All liquids used in hydronic heating systems expand when heated. For all practical purposes, liquids are incompressible. Any container completely filled with a liquid and sealed from the atmosphere will experience a rapid increase in pressure as the liquid is heated.

To prevent this from occurring, all closed-loop hydronic systems MUST be equipped with an expansion tank. Refer to expansion tank manufacturer's instructions for proper sizing and installation.

### Water circulation:

The hydronic air handler has a strict in press cycle which will circulate the water in the coil for 6 minutes per day to prevent water stagnation.

**PROCEDURE FOR CALCULATING THE TOTAL EQUIVALENT LENGTH OF PIPE**

Given piping assembly as shown in Figure 9 below, what is the total equivalent length of the system?

First determine the total straight pipe lengths; next refer to Table 4 to determine the equivalent straight pipe length for each fitting shown. Add together the equivalent lengths of piping and fittings.

- (3/4") Tubing 24 ft.
- 7 (3/4") 90 deg. Elbows 7 (1.9) = 13.3 ft.
- 5 (3/4") Side Port Tees 5 (3.8) = 19.0 ft.
- 1 (3/4") Taco air separator = .3 ft.
- 2 (3/4") Ball Valve 2 (.2) = .4 ft.

**Total Equivalent Length . . . . = 57 ft.**

**NOTICE**

**WHERE POSSIBLE THE LENGTH OF PIPE SHOULD NOT EXCEED 100 FEET TOTAL EQUIVALENT LENGTH.**

**ANY PIPING RUNNING THROUGH UNCONDITIONED SPACE MUST BE INSULATED TO PREVENT HEAT LOSS, AND POSSIBLE FREEZING OF THE LINE.**

**STICKERS INDICATING DIRECTION OF FLOW (WATER IN AND WATER OUT) ARE LABELED ON THE OUTSIDE OF THE CABINET. DO NOT REVERSE THESE LINES, AS THIS WILL CAUSE THE UNIT TO MALFUNCTION.**

**Piping Configuration**

When employing a Tankless Water Heater in a hydronic system, the system is considered an open-loop system when configured to simultaneously deliver both domestic hot water and space heating. By definition, if the circuit is sealed off from the atmosphere at all locations (as is true for most modern hydronic systems), it is called a **closed-loop system**. If the circuit is open to the atmosphere at *any point*, it is called an **open-loop system**.

**FIGURE 9 EQUIVALENT LENGTH CALCULATION**

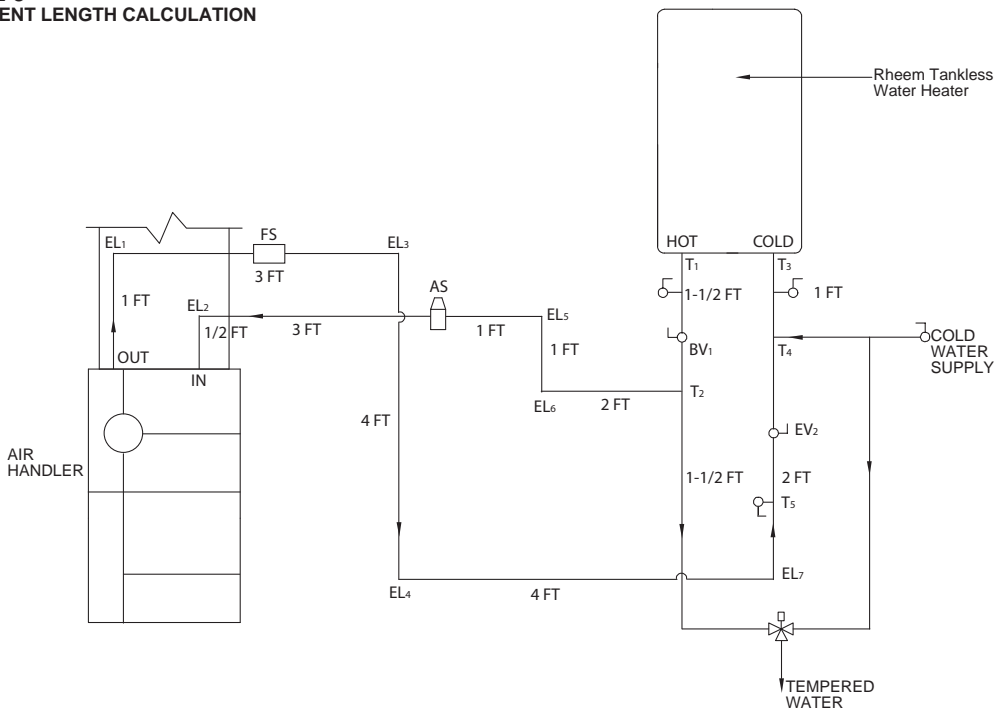

**Table 4 – Equivalent Length of Straight Pipe for Valves and Fittings (ft)**

	Diameter (in.)					
	0.375	0.5	0.75	1	1.25	1.5
Globe Valve	14.1	18.8	28.1	37.5	46.9	56.3
Angle Valve	6.3	8.3	12.5	16.7	20.8	25.0
Gate Valve	0.5	0.7	1.1	1.4	1.8	2.1
Ball Valve (BV)	0.1	0.1	0.2	0.3	0.3	0.4
90 Degree Standard Elbow	0.9	1.3	1.9	2.5	3.1	3.8
45 Degree Standard Elbow	0.5	0.7	1.0	1.3	1.7	2.0
Standard Tee with flow through run	0.6	0.8	1.3	1.7	2.1	2.5
Standard Tee with flow through branch	1.9	2.5	3.8	5.0	6.3	7.5



## Open-Loop System

If piping is done in accordance with the recommended schematic diagram shown in Figure 10, the following purge and priming procedure applies.

### PURGING AND PRIMING THE SYSTEM:

The following procedure describes how the system may be piped to eliminate the need for a "purge cart" to fill the system and remove entrapped air bubbles.

**STEP 1:** CLOSE the air separator venting valve.

**STEP 2:** CLOSE ball valve 3 (BV<sub>3</sub>);

**STEP 3:** OPEN drain valve 3 (DV<sub>3</sub>) to which a hose MUST be connected and draining to a sink, drain or outdoors.

**STEP 4:** CLOSE drain valves 1 & 2 (DV<sub>1</sub> and DV<sub>2</sub>) and OPEN ball valve 2 (BV<sub>2</sub>).

**STEP 5:** OPEN cold water supply main valve (ball valve 1 - BV<sub>1</sub>). The system will begin the prime/purge process using the street pressure. Entrapped air bubbles being pushed out of the system will be evident by a slight vibration of the discharge hose connected to drain valve 3 (DV<sub>3</sub>). The hose will stop vibrating when laminar flow is achieved.

**STEP 6:** CLOSE drain valve 3 (DV<sub>3</sub>);

**STEP 7:** OPEN ball valve 3 (BV<sub>3</sub>). The system is now purged, primed and ready to go.

**STEP 8:** OPEN the air separator venting valve.

**NOTE:** For an open-loop system, use expansion tank approved for potable water use only.

**FIGURE 10**  
TYPICAL PIPING ARRANGEMENT FOR DIRECT SPACE HEATING AND DOMESTIC WATER SUPPLY WITH TANKLESS

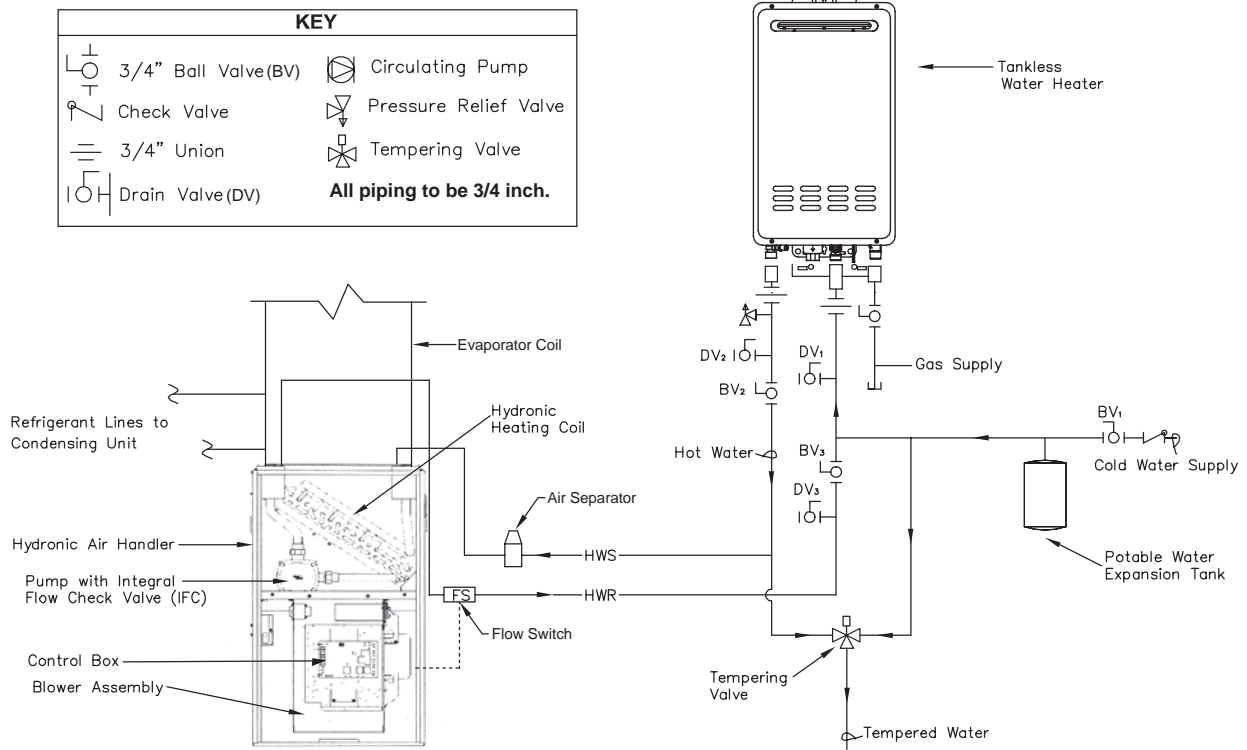

# ELECTRICAL WIRING

## ▲ WARNING

**TURN OFF ELECTRIC POWER AT FUSE BOX OR SERVICE PANEL BEFORE MAKING ANY ELECTRICAL CONNECTIONS. FAILURE TO DO SO CAN CAUSE ELECTRICAL SHOCK RESULTING IN PERSONAL INJURY OR DEATH.**

## ▲ WARNING

**THE CABINET MUST HAVE AN UNINTERRUPTED GROUND ACCORDING TO THE LATEST EDITION OF THE NATIONAL ELECTRICAL CODE (NEC), ANSI/NFPA70- OR IN CANADA, THE CANADIAN ELECTRICAL CODE, CSA-C221 OR LOCAL CODES THAT APPLY. DO NOT USE GAS PIPING AS AN ELECTRICAL GROUND. A GROUND SCREW IS PROVIDED IN THE JUNCTION BOX. FAILURE TO DO SO CAN CAUSE ELECTRICAL SHOCK, RESULTING IN PERSONAL INJURY OR DEATH.**

## ▲ WARNING

**THIS AIR HANDLER IS EQUIPPED WITH A BLOWER DOOR SAFETY SWITCH. DO NOT DISABLE THIS SWITCH. FAILURE TO FOLLOW THIS WARNING CAN RESULT IN ELECTRICAL SHOCK, PERSONAL INJURY OR DEATH.**

**IMPORTANT:** The air handler must be installed so that the electrical components are protected from water (condensate).

Before proceeding with the electrical connections, be certain that the voltage, frequency and phase corresponds to that specified on the air handler rating plate. For single air handler application, maximum over-current protection is 15 amperes.

## ▲ CAUTION

**IF A DISCONNECT SWITCH IS TO BE MOUNTED ON THE UNIT, SELECT A LOCATION WHERE A DRILL OR FASTENER WILL NOT CONTACT ELECTRICAL OR HYDRONIC COMPONENTS. ELECTRICAL SHOCK CAN CAUSE PERSONAL INJURY OR DEATH.**

**NOTE:** Prior to making any electrical connections, ensure that supply voltage, frequency, and phase are as specified on unit rating plate.

Check to ensure that the existing electrical service is adequate to handle the additional load imposed by the Hydronic Air Handler. Refer to unit wiring diagram for proper electrical connections.

All electrical connections **MUST** comply with NEC and any other local codes or ordinances having

jurisdiction. USE COPPER WIRE ONLY. Provide separate branch electric circuit with field supplied disconnect switch.

Location of disconnect switch to be in clear site, accessible and in close proximity to the unit.

Correct polarity **MUST** be maintained for 115 V wiring. If polarity is incorrect, unit will **NOT** operate.

Use a separate fused branch electrical circuit containing a properly sized fuse or circuit breaker. Run this circuit directly from the main switch box to an electrical disconnect that is readily accessible and located near the air handler. Connect from the electrical disconnect to the junction box on the left side of the air handler, inside the blower compartment. For the proper connection, refer to the appropriate wiring diagram located on the inside cover of the air handler control box and in these instructions.

The electrical junction box may be moved to the right side if necessary. A knockout is provided. Seal the opposite hole with plug provided.

Make all electrical connections in accordance with the latest edition of the National Electrical Code, ANSI/NFPA70 and local codes having jurisdiction.

These may be obtained from:

National Fire Protection Association, Inc.  
Batterymarch Park  
Quincy, MA 02269

CSA - International  
178 Rexdale Blvd.  
Etobicoke (Toronto), Ontario  
Canada M9W, 1R3

# THERMOSTAT

The room thermostat must be compatible with the integrated air handler control on the air handler. Generally, all thermostats that are not of the "current robbing" type are compatible with the integrated air handler control. The low voltage wiring should be sized as shown (see Figures 12 through 15).

**NOTE:** Do not use 24 volt control wiring smaller than No. 18 AWG.

Install the room thermostat in accordance with the instruction sheet packed in the box with the thermostat. Run the thermostat lead wires inside the blower compartment and connect to low voltage terminals as shown on the wiring diagram. Never install the thermostat on an outside wall or where it will be influenced by drafts, concealed hot or cold water pipes or ducts, lighting fixtures, radiation from fireplace, sun rays, lamps, televisions, radios or air streams from registers. Refer to instructions packed with the thermostat for "heater" selection or adjustment.

# ACCESSORIES

## FIELD-INSTALLED

## OPTION ACCESSORIES

## ELECTRONIC AIR CLEANER

Line voltage power can be supplied from the screw terminal "EAC" and a line voltage neutral screw terminal on the control board. This will power the electronic air cleaner whenever the circulating air blower is in operation.

## Expansion Tank:

Expansion tank for closed systems air separator – TACO Model 49-075.

**FIGURE 11**  
FIELD WIRING DIAGRAM

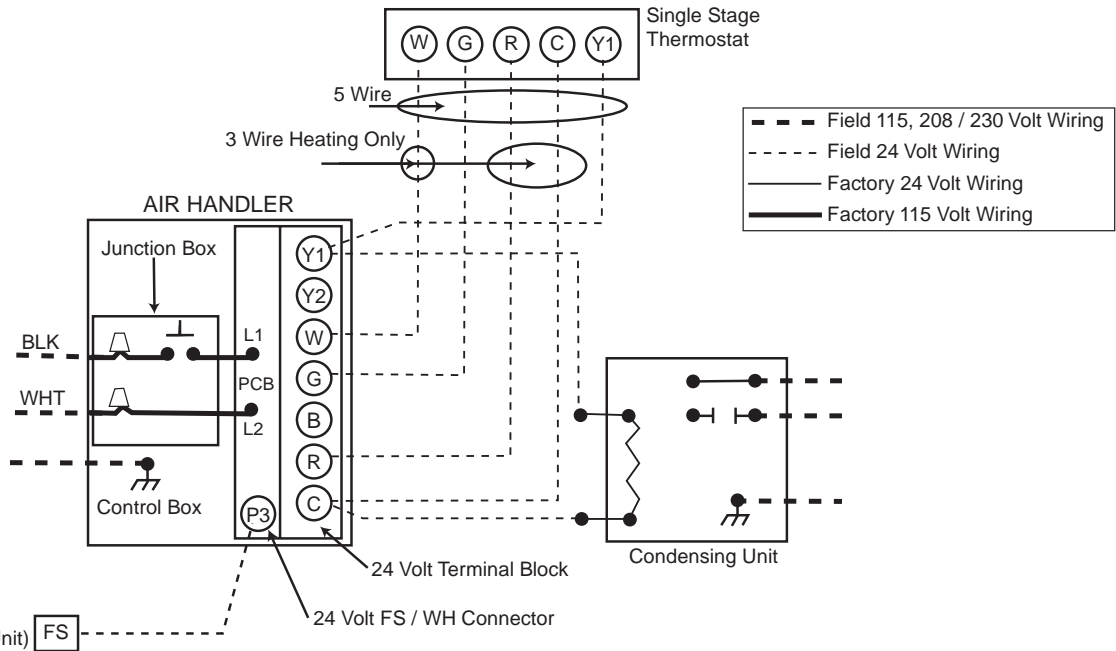

**FIGURE 12**  
THERMOSTAT WIRING DIAGRAMS  
SINGLE STAGE AIR HANDLER W/SINGLE STAGE A/C

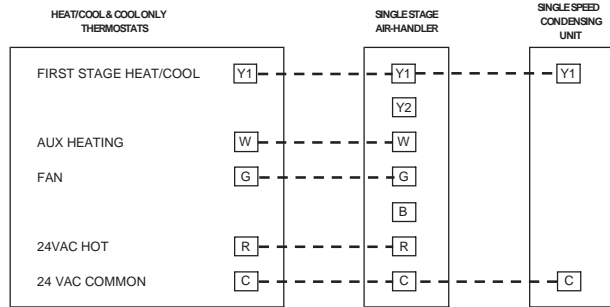

**FIGURE 14**  
THERMOSTAT WIRING DIAGRAMS  
SINGLE STAGE HYDRONIC FURNACE W/TWO STAGE A/C

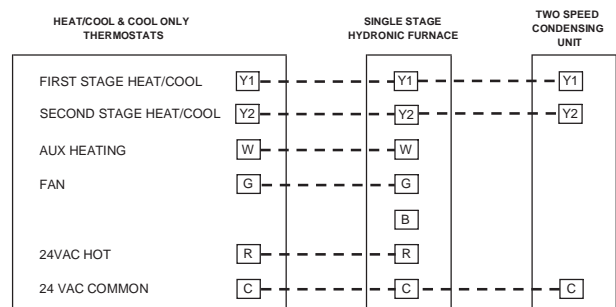

**FIGURE 13**  
THERMOSTAT WIRING DIAGRAMS  
SINGLE STAGE AIR HANDLER W/SINGLE STAGE HEAT PUMP\*

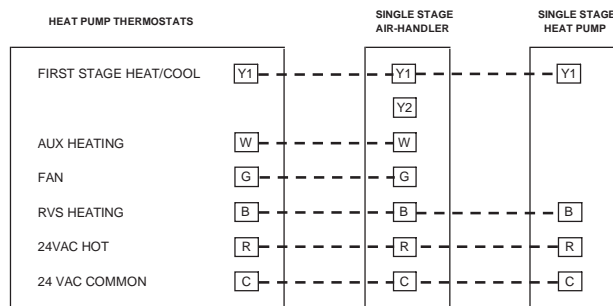

**FIGURE 15**  
THERMOSTAT WIRING DIAGRAMS  
SINGLE STAGE HYDRONIC FURNACE W/TWO STAGE HEAT PUMP

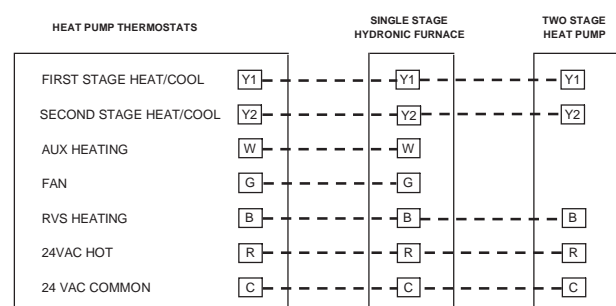

\*Requires Fossil Fuel Kit  
Refer to Kit for further wiring instructions.

## System Low Voltage Wiring Diagrams

**NOTE:** Local codes may require thermostat wiring to be routed through conduit or raceways. In such instances splices can be made inside the Hydronic Air Handler. All wiring must be NEC Class I and must be separated from incoming power leads.

Provide field-supplied disconnect for maximum fuse or circuit breaker sizes, as required by code.

Transformer is factory wired for 115V operation.

The secondary circuit of the transformer is protected by a 3-amp fuse mounted on the printed circuit board.

## Dip Switch Options:

Refer to the appropriate diagram for the proper dip switch setting to be used with the designed application (Figure 17).

## THERMOSTAT INSTALLATION:

Thermostat should be mounted:

- approximately 5 ft. (1.5 m) from floor

- close to or in a frequently used room, preferably on an inside, partitioning wall

- on a section of wall without pipes or duct work.

Thermostat should NOT be mounted:

- close to a window, on an outside wall, or next to a door leading to the outside.

**TABLE 5**

Wire Gauge	Maximum Distance (feet)
18 gauge	60
16 gauge	100
14 gauge	160
12 gauge	250

**FIGURE 16**  
HYDRONIC AIR-HANDLER CONTROL BOARD

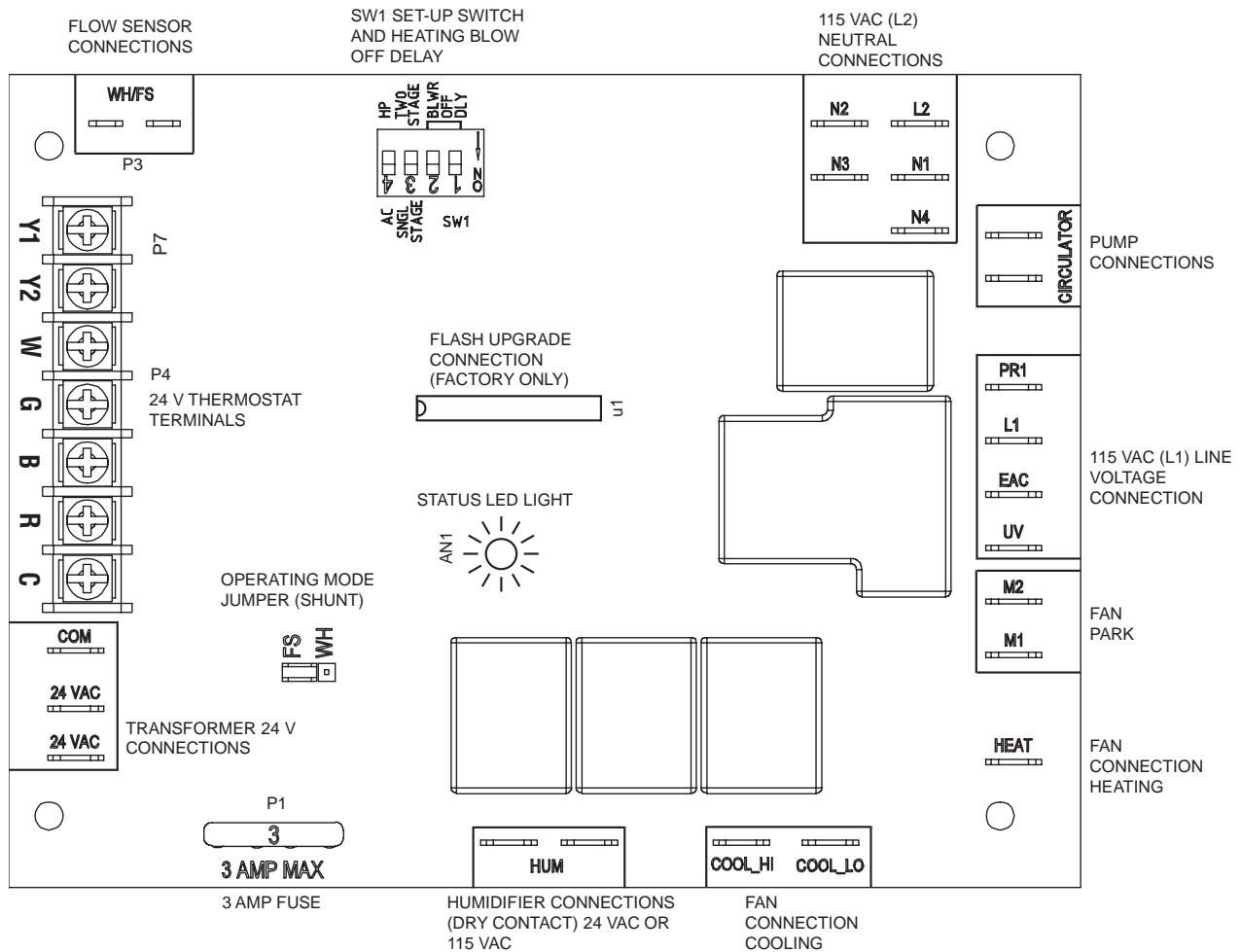

**NOTES:**

1. For proper operation of an open loop system (refer to Figures 11 and 17), the jumper (shunt) position on PCB point "P7" should be in the FS position.
2. When changing shunt position ensure that unit power is turned off.

- exposed to direct light and heat from a lamp, sun, fireplace, or other heat-radiating object which may cause a false reading.
- close to or in direct airflow from supply registers and return-air grilles
- In areas with poor air circulation, such as behind a door or in an alcove

Refer to thermostat wiring diagram and thermostat installation instructions for further details.

**FIGURE 17  
DIP SWITCH POSITIONS**

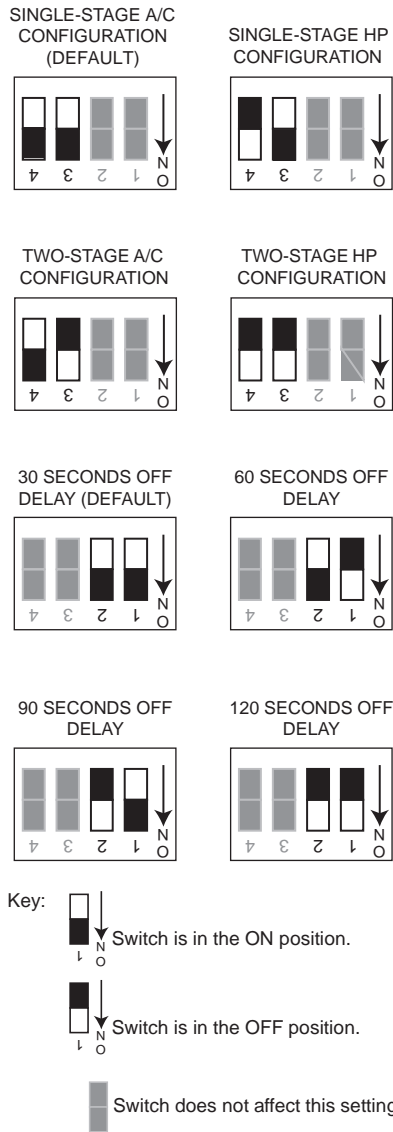

### START-UP PROCEDURE (HEATING ONLY):

The following conditions must be met prior to unit start-up.

Debris from soldering and/or other installation activities can cause equipment failure. Ensure that all associated lines and appurtenances are free of debris.

Check to ensure that unit is secure.

Check that blower wheel rotates freely within the scroll housing.

Check all wiring to ensure that connections are tight.

Check all ductwork and pipe connections to ensure proper seal.

Check to ensure that all packaging wraps are removed from equipment.

Ensure that front access doors are properly installed.

Check to ensure proper connection(s) to the appropriate blower speed tap (Heat /Cool – High and Low). Refer to Dry Air Delivery Table and/or the appropriate wiring diagram(s) in this manual.

Perform all safety and start-up checks for Tankless Water Heater as per manufacturer's instructions.

Having verified all preceding checks, the Air Handler's Start-Up Procedure is as follows:

**STEP 1:** Purge and fill system; follow appropriate purging procedure as laid out in this manual in section titled "Purging and Priming the System".

**STEP 2:** Turn on power supply to air handler. Caution: blower and/or circulator may start to operate if thermostat is on and a call is present.

**STEP 3:** Turn thermostat ON and switch system to the heating mode. The thermostat shall be set higher than the actual room temperature; this will cause the circulator to energize and initiate the heating cycle. (If the pump does not start, or the Air Handler is not producing heat, refer to the Troubleshooting Section, in this manual).

**STEP 4:** Program room thermostat as desired by homeowner.

### START-UP PROCEDURE (COOLING SYSTEM)

Refer to field-supplied evaporator coil and outdoor unit manufacturer's Installation Instructions for system hook-up, start-up instructions and refrigerant-charging method details.

### TROUBLESHOOTING BLOWER AND/OR PUMP MOTOR AND CONTROLS

**If blower and/or pump motor does not run:**

Turn OFF power and check the following:

1. Check that door switch is in the CLOSED position.
2. Check 3 amp fuse on Printed Circuit Board (PCB).
3. Check for 24 VAC between COM and 24 VAC on IAC. If no voltage is present, check transformer.
4. Check all connections for kinks which could cause loose connections. Ensure connections are secure.
5. Verify that approximately 120 VAC is present across L1 and L2.

# SEQUENCE OF OPERATION

## COOLING

### Single Stage Cooling

- When the thermostat calls for cooling (Y), there is a 1 second delay then the control energizes the high blower tap (COOL\_HI).
- When the thermostat ends the call for cooling (Y), there is a 30 second cooling off delay then the control de-energizes the high blower tap (COOL\_HI).
- A call for cooling has priority over continuous fan.

### Two Stage Cooling

- When the thermostat calls for cooling (Y), there is a 1 second delay then the control energizes the low blower tap (COOL\_LO).
- When the thermostat calls for 2nd stage cooling (Y2), the control de-energizes the low blower tap (COOL\_LO). There is a 1 second delay and the control energizes the high blower tap (COOL\_HI).
- When the thermostat ends the call for 2nd stage cooling (Y2), the control de-energizes the high blower tap (COOL\_HI) and the control energizes the low blower tap (COOL\_LO).
- When the thermostat ends the call for cooling (Y), there is a 30 second cooling off delay then the control de-energizes the low blower tap (COOL\_LO).

## HEATING (HYDRONIC)

- When the thermostat “calls for heat,” the circuit between R and W is completed. The control monitors the FS input and energizes the circulating pump if the FS signal is present. The indoor blower will then be activated.

If the FS signal is NOT present, the control will energize the circulating pump for 60 seconds in an attempt to activate the Flow Switch (FS). If the FS signal does not become active during this time, the control will de-energize the pump wait 60 seconds and then retry the sequence until the FS signal is present. During this time the Status LED will rapidly flash, indicating that a heat demand is present, but not being satisfied because of the state of the FS input signal.

## HEATING (Heat pump is the primary source of heat)

### Single Stage Heating

- The thermostat calls for heating (Y, R, and B), there is a 1 second delay then the control energizes the high blower tap (COOL\_HI).

- When the thermostat ends the call for cooling (Y), there is a 30 second cooling off delay then the control de-energizes the high blower tap (COOL\_HI).
- When the thermostat calls for emergency heat (W), the hydronic heating mode is activated.

### Two-Stage Heating

- The thermostat calls for heating (Y, R, and B), there is a 1 second delay then the control energizes the low blower tap (COOL\_LO).
- When the thermostat calls for 2nd stage heating (Y2), the control de-energizes the low blower tap (COOL\_LO). There is a 1 second delay and the control energizes the high blower tap (COOL\_HI).
- When the thermostat ends the call for 2nd stage heating (Y2), the control de-energizes the high blower tap (COOL\_HI) and the control energizes the low blower tap (COOL\_LO).
- When the thermostat ends the call for heating (Y), there is a 30 second cooling off delay then the control de-energizes the low blower tap (COOL\_LO).
- When the thermostat calls for emergency heat (W), the hydronic heating mode is activated.
- If the room temperature should continue to fall, circuit R and W is completed by the second-stage heat room thermostat. Circuit R-W energizes a pump. The completed circuit will energize supplemental heat. The heat pump will de-energize when the auxiliary heat is activated. A dual fuel thermostat or fossil fuel kit will be required.

## BLOWER TIME DELAY (HEATING OR COOLING)

All models are equipped with a blower time delay (BTD) in lieu of a blower relay (BR) (see Figure 21). The blower will run for 30 seconds after the blower time delay (BTD) is de-energized.

## DEFROST (DEFROST HEAT CONTROL)

- For sequence of operation of defrost controls, see outdoor heat pump installation instructions.
- Supplemental heat during defrost can be provided by connecting the purple (PU) pigtail in the outdoor unit to the W on the thermostat. This will complete the circuit between R and W through a set of contacts in the defrost

relay (DR) when the outdoor heat pump is in defrost. This circuit, if connected, will help prevent cold air from being discharged from the indoor unit during defrost.

- For most economical operation, if cold air is not of concern during defrost, the purple wire can be left disconnected. Supplemental heat will then come on only when called for by second stage room thermostat.

## EMERGENCY HEAT (HEATING HEAT PUMP)

- If selector switch on thermostat is set to the emergency heat position, the heat pump will be locked out of the heating circuit, and all heating will be hydronic heat. Jumper should be placed between W and E on the thermostat sub-base so that the electric heat control will transfer to the first stage heat on the thermostat. This will allow the indoor blower to cycle on and off with the electric heat when the fan switch is in the auto position.

## ROOM THERMOSTAT (ANTICIPATOR SETTING)

See instructions with outdoor section, condensing unit or heat pump for recommended room thermostats.

- The thermostat should be mounted 4 to 5 feet above the floor on an inside wall of the living room or a hallway that has a good air circulation from the other rooms being controlled by the thermostat. It is essential that there be free air circulation at the location of the same average temperature as other rooms being controlled. Movement of air should not be obstructed by furniture, doors, draperies, etc. The thermostat should not be mounted where it will be affected by drafts, hot or cold water pipes or air ducts in walls, radiant heat from fireplaces, lamps, the sun, T.V. or an outside wall. See instructions sheet packaged with thermostat for mounting and installation instructions.

**TABLE 6 HYDRONIC AIR HANDLER AIR FLOW PERFORMANCE - RHWB**

Model	Blower / Motor HP Inches [mm]	Speed	CFM [L/s] Air Delivery External Static Pressure Inches Water Column [kPa]									
			0.1 [.02]	0.2 [.05]	0.3 [.07]	0.4 [.10]	0.5 [.12]	0.6 [.15]	0.7 [.17]	0.8 [.19]	0.9 [.22]	1.0 [.24]
RHWB-04WMP36A	11 x 7 [279 x 178] / 1/2 [373]	Low	794 [375]	775 [366]	749 [353]	719 [339]	686 [324]	655 [309]	621 [293]	590 [278]	534 [252]	473 [223]
		M-Lo	1036 [489]	1024 [483]	1002 [473]	977 [461]	922 [435]	895 [423]	865 [408]	826 [390]	761 [359]	689 [325]
		M-Hi	1202 [567]	1176 [555]	1160 [547]	1100 [519]	1073 [506]	1047 [494]	1008 [476]	969 [457]	926 [437]	890 [420]
		High	1356 [640]	1336 [631]	1301 [614]	1266 [597]	1235 [583]	1202 [567]	1156 [546]	1093 [516]	1030 [486]	959 [453]
RHWB-06WMP48A	11 x 7 [279 x 178] / 3/4 [559]	Low	921 [435]	915 [432]	886 [418]	876 [413]	855 [404]	841 [397]	817 [386]	780 [368]	734 [346]	690 [326]
		M-Lo	1189 [561]	1180 [557]	1179 [556]	1137 [537]	1131 [534]	1102 [520]	1072 [506]	1030 [486]	985 [465]	915 [432]
		M-Hi	1335 [630]	1315 [621]	1306 [616]	1307 [617]	1277 [603]	1246 [588]	1210 [571]	1161 [548]	1090 [514]	1019 [481]
		High	1841 [869]	1795 [847]	1747 [824]	1681 [793]	1622 [765]	1560 [736]	1500 [708]	1420 [670]	1358 [641]	1288 [608]
RHWB-08WRP60A	11 x 10 [279 x 254] 3/4 [559]	Low	1319 [623]	1307 [617]	1300 [614]	1240 [585]	1236 [583]	1210 [571]	1177 [555]	1149 [542]	1100 [519]	1032 [487]
		M-Lo	1484 [700]	1480 [698]	1471 [694]	1463 [690]	1418 [669]	1385 [654]	1359 [641]	1314 [620]	1246 [588]	1166 [550]
		M-Hi	1687 [796]	1676 [791]	1671 [789]	1611 [760]	1586 [749]	1553 [733]	1513 [714]	1453 [686]	1389 [656]	1284 [606]
		High	1971 [930]	1974 [932]	1948 [919]	1929 [910]	1871 [883]	1806 [852]	1751 [826]	1699 [802]	1610 [760]	1511 [713]
RHWB-10WRP60A	11 x 10 [279 x 254] / 3/4 [559]	Low	1299 [613]	1294 [611]	1308 [617]	1279 [604]	1257 [593]	1231 [581]	1205 [569]	1165 [550]	1122 [530]	1053 [497]
		M-Lo	1515 [715]	1519 [717]	1499 [707]	1487 [702]	1415 [668]	1418 [669]	1394 [658]	1348 [636]	1296 [612]	1221 [576]
		M-Hi	1684 [795]	1695 [800]	1693 [799]	1663 [785]	1620 [765]	1586 [749]	1569 [740]	1514 [715]	1451 [685]	1365 [644]
		High	1954 [922]	1971 [930]	1974 [932]	1982 [935]	1973 [931]	1944 [917]	1917 [905]	1818 [858]	1775 [838]	1700 [802]
RHWB-04WMX36A	11 x 7 [279 x 178] / 1/2 [343]	Low	960 [453]	891 [420]	836 [394]	781 [368]	731 [344]	682 [322]	630 [297]	578 [273]	540 [255]	460 [217]
		Med-low	1178 [555]	1118 [527]	1068 [504]	1017 [479]	973 [459]	922 [435]	877 [414]	833 [393]	781 [369]	730 [345]
		Med-high	1323 [624]	1269 [598]	1222 [576]	1180 [556]	1130 [533]	1089 [514]	1051 [496]	1006 [475]	958 [452]	914 [431]
		High	1481 [698]	1431 [675]	1381 [651]	1333 [629]	1291 [609]	1250 [590]	1209 [571]	1168 [551]	1122 [530]	1085 [512]
RHWB-06WMX48A	11 x 7 [279 x 178] / 3/4 [559]	Low	1092 [515]	1037 [489]	992 [468]	938 [442]	896 [422]	849 [401]	790 [373]	739 [349]	689 [325]	633 [299]
		Med-low	1360 [641]	1308 [617]	1264 [596]	1222 [576]	1174 [554]	1138 [537]	1095 [517]	1027 [485]	988 [466]	945 [446]
		Med-high	1462 [689]	1424 [672]	1378 [650]	1340 [632]	1300 [614]	1263 [596]	1223 [577]	1185 [559]	1147 [541]	1111 [524]
		High	1779 [839]	1743 [822]	1716 [809]	1674 [790]	1698 [801]	1662 [784]	1624 [776]	1588 [749]	1525 [720]	1427 [673]
RHWB-08WRX60A	11 x 10 [279 x 254] / 3/4 [559]	Low	1533 [723]	1475 [696]	1412 [666]	1357 [640]	1287 [607]	1239 [585]	1185 [559]	1129 [533]	1069 [505]	1002 [473]
		Med-low	1658 [782]	1604 [757]	1551 [731]	1500 [707]	1438 [679]	1392 [657]	1336 [631]	1277 [603]	1231 [581]	1174 [554]
		Med-high	1842 [869]	1782 [841]	1747 [824]	1701 [802]	1645 [776]	1601 [756]	1547 [730]	1502 [709]	1456 [687]	1401 [661]
		High	2131 [1005]	2074 [978]	2030 [958]	1969 [929]	1929 [910]	1885 [890]	1833 [865]	1786 [843]	1744 [823]	1688 [797]
RHWB-10WRX60A	11 x 10 [279 x 254] / 3/4 [559]	Low	1598 [754]	1533 [723]	1471 [694]	1401 [661]	1344 [634]	1286 [607]	1221 [576]	1162 [548]	1099 [519]	1020 [481]
		Med-low	1731 [816]	1674 [790]	1605 [757]	1546 [729]	1488 [702]	1435 [607]	1377 [650]	1320 [623]	1264 [597]	1206 [569]
		Med-high	1943 [916]	1877 [885]	1822 [859]	1762 [831]	1707 [806]	1651 [779]	1609 [759]	1552 [732]	1498 [707]	1446 [682]
		High	2197 [1036]	2151 [1015]	2095 [988]	2047 [966]	1995 [942]	1949 [920]	1896 [895]	1847 [872]	1800 [850]	1745 [824]

Note: When selecting a motor speed tap, use the lowest speed tap possible to achieve the rated cooling air-flow at the external static pressure for the application (including cooling coil).

## DIRECT DRIVE INSTRUCTIONS FOR CHANGING BLOWER SPEED

### **▲ WARNING**

**DISCONNECT THE ELECTRICAL SUPPLY TO THE AIR HANDLER BEFORE ATTEMPTING TO CHANGE THE BLOWER SPEED. FAILURE TO DO SO CAN CAUSE ELECTRICAL SHOCK RESULTING IN PERSONAL INJURY OR DEATH.**

The blower motor must be wired for blower speeds required for normal operation.

If additional blower speed taps are available (leads connected to "M1" and "M2" on the electronic control), speeds may be changed if necessary to fit requirements of the particular installation. Reconnect the unused motor leads to "M1" or "M2." Check motor lead color for speed designation.

Heating speeds should not be reduced where it could cause the air handler air temperature rise to exceed the maximum outlet air temperature specified for the unit.

**IMPORTANT:** Always check air temperature rise after changing the heating speed for any reason.

# MAINTENANCE

## ▲ WARNING

THESE INSTRUCTIONS ARE INTENDED AS AN AID TO QUALIFIED SERVICE PERSONNEL FOR PROPER INSTALLATION, ADJUSTMENT AND OPERATION OF THIS UNIT. READ THESE INSTRUCTIONS THOROUGHLY BEFORE ATTEMPTING INSTALLATION OR OPERATION. FAILURE TO FOLLOW THESE INSTRUCTIONS MAY RESULT IN IMPROPER INSTALLATION, ADJUSTMENT, SERVICE OR MAINTENANCE, POSSIBLY RESULTING IN FIRE, ELECTRICAL SHOCK, CARBON MONOXIDE POISONING, EXPLOSION, PROPERTY DAMAGE, PERSONAL INJURY OR DEATH.

DISCONNECT MAIN ELECTRICAL POWER TO THE UNIT BEFORE ATTEMPTING ANY MAINTENANCE. FAILURE TO DO SO CAN CAUSE ELECTRICAL SHOCK RESULTING IN PERSONAL INJURY OR DEATH.

**TABLE 7  
FILTER SIZES**

UPFLOW FILTER SIZES				
AIR HANDLER WIDTH	INPUT MBTU/HR	BOTTOM SIZE	SIDE SIZE	QUANTITY
17 <sup>1</sup> / <sub>2</sub> "	45, 60	15 <sup>3</sup> / <sub>4</sub> " X 25"	15 <sup>3</sup> / <sub>4</sub> " X 25"	1
24 <sup>1</sup> / <sub>2</sub> "	80, 100	22 <sup>3</sup> / <sub>4</sub> " X 25"	15 <sup>3</sup> / <sub>4</sub> " X 25"	1

## FILTERS

Keep the filters clean at all times. Vacuum dirt from filter, wash with detergent and water, air dry thoroughly and reinstall.

**NOTE:** Some filters must be resized to fit certain units and applications. See Table 7 and Figures 18 and 19.

- 24.5" - 80,000 and 100,000 BTU/HR unit requires removal of a 7" segment of filter and frame to get the proper width for a side filter.

## ▲ CAUTION

**DO NOT OPERATE THE SYSTEM FOR EXTENDED PERIODS WITHOUT FILTERS. A PORTION OF THE DUST ENTRAINED IN THE AIR MAY TEMPORARILY LODGE IN THE AIR DUCT RUNS AND AT THE SUPPLY REGISTERS. THIS RESIDUE CAN SOIL CEILINGS, WALLS, DRAPES, CARPETS AND OTHER HOUSEHOLD ARTICLES.**

**FIGURE 18**

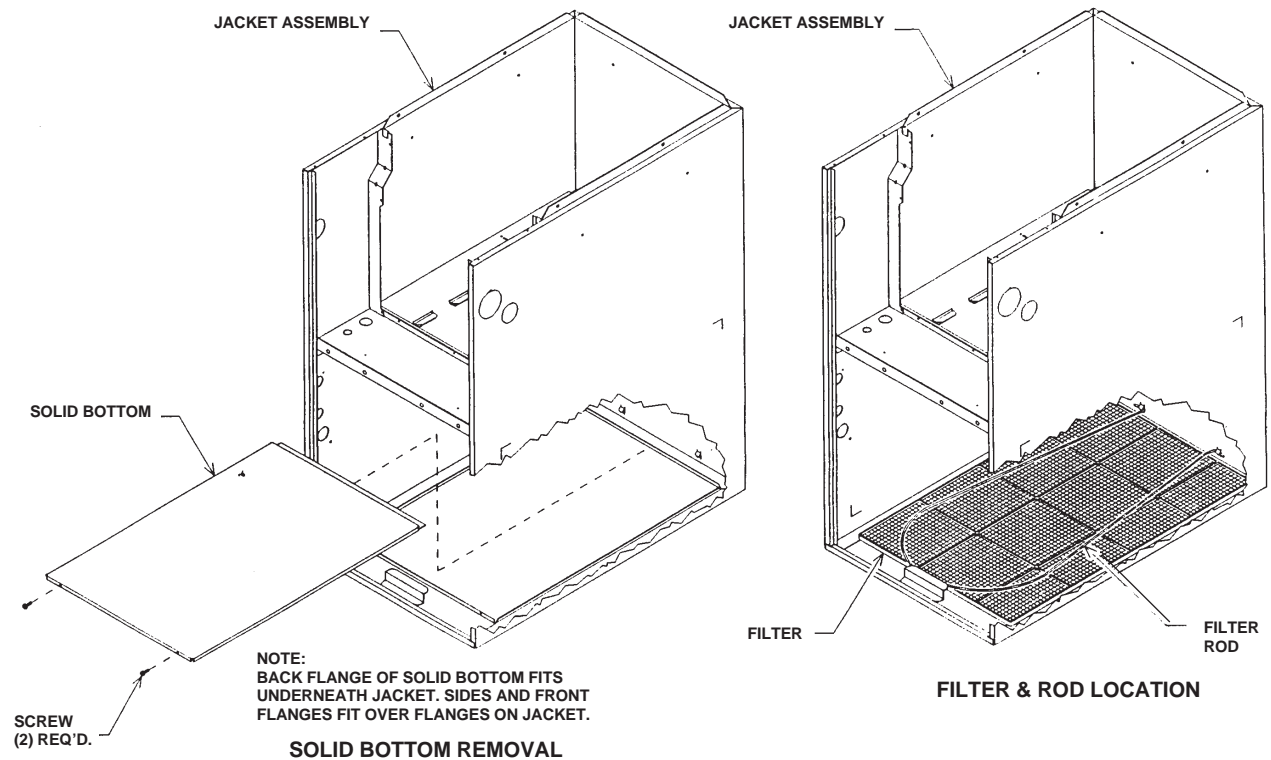



**FIGURE 19**  
**FILTER LOCATIONS**

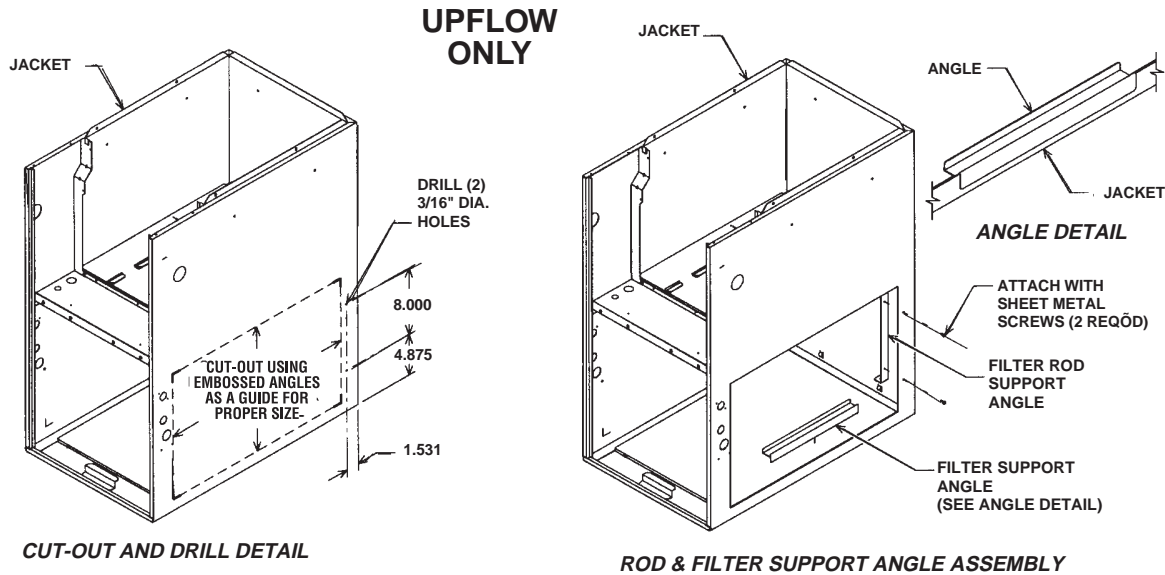

## LUBRICATION

**IMPORTANT: DO NOT** attempt to lubricate the bearings on the blower motor or the induced draft blower motor. Addition of lubricants can reduce the motor life and void the warranty.

The blower motor and induced draft blower motor are permanently lubricated by the manufacturer and do not require further attention.

The blower motor and induced draft blower motor must be cleaned periodically by a qualified installer, service agency, or the gas supplier to prevent the possibility of overheating due to an accumulation of dust and dirt on the windings or on the motor exterior. And, as suggested elsewhere in these instructions, the air filters should be kept clean. Dirty filters can restrict airflow. The motor depends upon sufficient air flowing across and through it to keep from overheating.

## SYSTEM OPERATION INFORMATION

### Advise The Customer

1. Keep the air filters clean. The heating system will operate better, more efficiently and more economically.

2. Arrange the furniture and drapes so that the supply air registers and the return air grilles are unobstructed.
3. Close doors and windows. This will reduce the heating load on the system.
4. Avoid excessive use of kitchen exhaust fans.
5. Do not permit the heat generated by television, lamps or radios to influence the thermostat operation.
6. Except for the mounting platform, keep all combustible articles 3 feet from the air handler and vent system.
7. **IMPORTANT:** Replace all blower doors and compartment covers after servicing the air handler. Do not operate the unit without all panels and doors securely in place.
8. Explain proper operation of the system with constant air circulation.

## ANNUAL INSPECTION

- The air handler should operate for many years without excessive scale build-up in the flue passageways. However, it is recommended that a qualified installer, service agency, or the gas supplier annually inspect

the flue passageways, the vent system and the main burners for continued safe operation. Pay particular attention to deterioration from corrosion or other sources.

- **IMPORTANT:** It is recommended that at the beginning and at approximately half way through the heating season, a visual inspection be made of the main burner flames for the desired flame appearance by a qualified installer, service agency or the gas supplier. If the flames are distorted and/or there is evidence of back pressure, check the vent and inlet air system for blockage. If there is carbon and scale in the heat exchanger tubes, the heat exchanger assembly should be replaced.

## REPLACEMENT PARTS

See sheet enclosed with air handler for replacement part information.

## TROUBLESHOOTING

Refer to Figure 20 for determining cause of unit problems.

## WIRING DIAGRAMS

Figure 21 are complete wiring diagrams for the air handler and power sources.

**FIGURE 20**  
**GENERAL TROUBLESHOOTING CHART**

General Troubleshooting Chart		
Warning: Disconnect all power to unit before servicing. Failure to shut off power can cause electrical shock resulting in personal injury or death.		
Symptom	Possible Cause	Remedy
Unit will not run	Power off or loosen electrical connection	Check for correct voltage at control
	Thermostat out of calibration - set too high	Check for correct voltage at control
	Call for domestic hot water - air handler disabled until call ends. Unit is operating as designed.	Unit is operating as designed
	Blown fuses / tripped breaker	Replace fuses / reset breaker
	Transformer defective	Check wiring—replace transformer
Insufficient heating	Improperly sized air handler or water heater	Recalculate load
	Improper indoor air flow	Check motor speed tap setting
Pump does not run	Call for domestic hot water—air handler disabled until call ends. Unit is operating as designed.	Unit is operating as designed
	Power off or loosen electrical connection	Check line voltage at pump
		Check wires and connectors
		Check pump capacitor
Blower does not run	Call for domestic hot water - air handler disabled until call ends. Unit is operating as designed.	Unit is operating as designed
	Power off or loosen electrical connection	Check line voltage at blower motor
		Check wires and connectors
		Check blower motor capacitor
Water does not flow	Water lines are air locked	Purge air from lines

**FIGURE 21**  
ELECTRICAL WIRING DIAGRAM – PSC MODELS

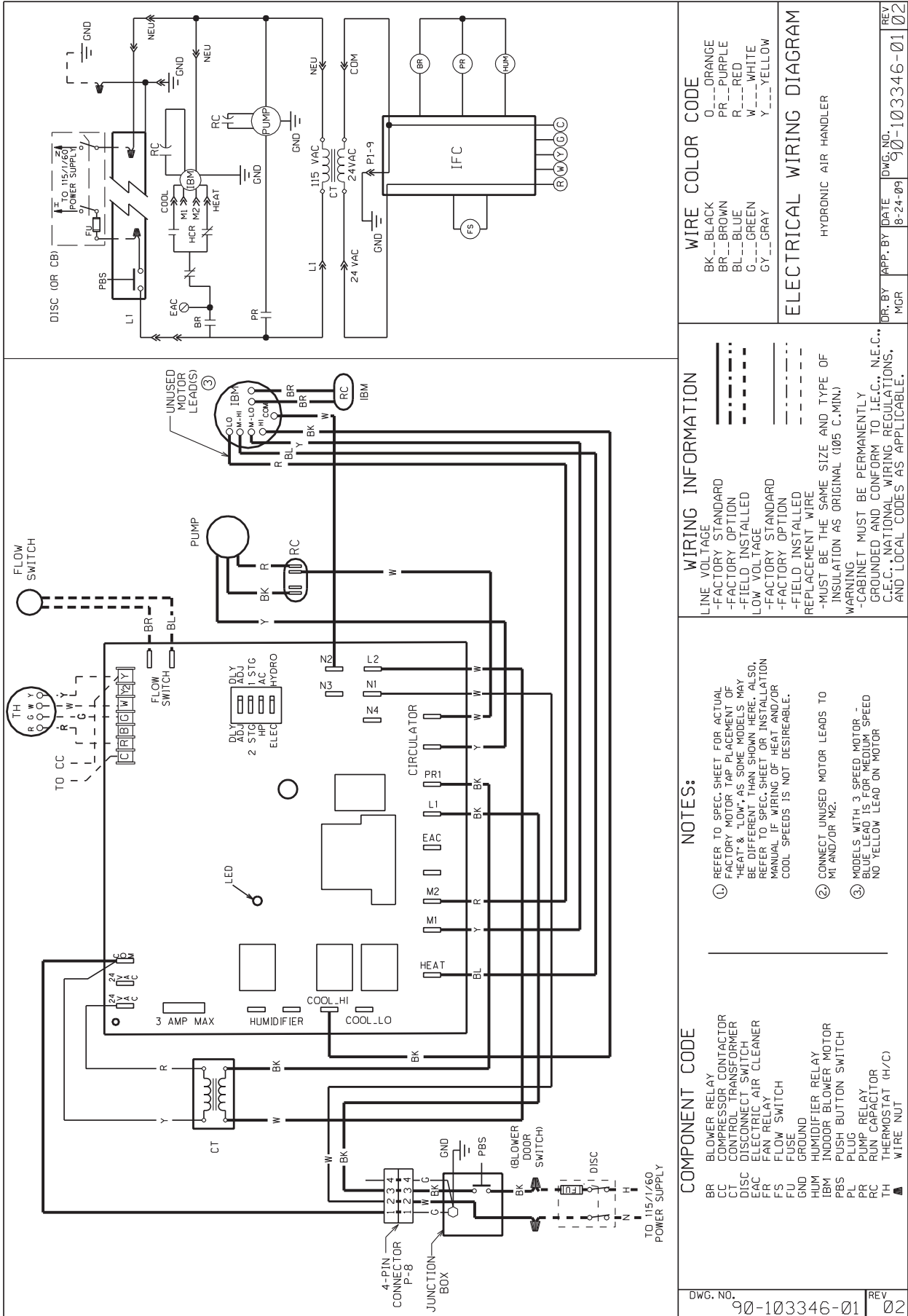

**WIRE COLOR CODE**

BK	BLACK
BR	BROWN
BL	BLUE
G	GREEN
GY	GRAY
O	ORANGE
PR	PURPLE
R	RED
W	WHITE
Y	YELLOW

**ELECTRICAL WIRING DIAGRAM**  
HYDRONIC AIR HANDLER

DR. BY: MGR | APP. BY: DATE: 8-24-09 | DWG. NO.: 90-103346-01 | REV: 02

- WIRING INFORMATION**
- LINE VOLTAGE
  - FACTORY STANDARD
  - FACTORY OPTION
  - FIELD INSTALLED
  - LOW VOLTAGE
  - FACTORY STANDARD
  - FACTORY OPTION
  - REPLACEMENT WIRE
  - MUST BE THE SAME SIZE AND TYPE OF INSULATION AS ORIGINAL (105 C. MIN.)
- NOTES:**
- REFER TO SPEC. SHEET FOR ACTUAL FACTORY MOTOR TAP PLACEMENT OF "HEAT" & "LOW" AS SOME MODELS MAY BE DIFFERENT THAN SHOWN HERE. ALSO, REFER TO SPEC. SHEET OR INSTALLATION MANUAL IF WIRING OF HEAT AND/OR COOL SPEEDS IS NOT DESIRABLE.
  - CONNECT UNUSED MOTOR LEADS TO M1 AND/OR M2.
  - MODELS WITH 3 SPEED MOTOR - BLUE LEAD IS FOR MEDIUM SPEED NO YELLOW LEAD ON MOTOR

**COMPONENT CODE**

BR	BLOWER RELAY
CC	COMPRESSOR CONTACTOR
CT	CONTROL TRANSFORMER
DISC	DISCONNECT SWITCH
EAC	ELECTRIC AIR CLEANER
FR	FAN RELAY
FS	FLOW SWITCH
FU	FUSE
GND	GROUND
HUM	HUMIDIFIER RELAY
IBM	INDOOR BLOWER MOTOR
PBS	PUSH BUTTON SWITCH
PL	PLUG
PR	PUMP RELAY
RC	RUN CAPACITOR
TH	THERMOSTAT (H/C)
▲	WIRE NUT

DWG. NO. 90-103346-01 | REV: 02

**FIGURE 22**  
ELECTRICAL WIRING DIAGRAM – ECO TECH™ MODELS

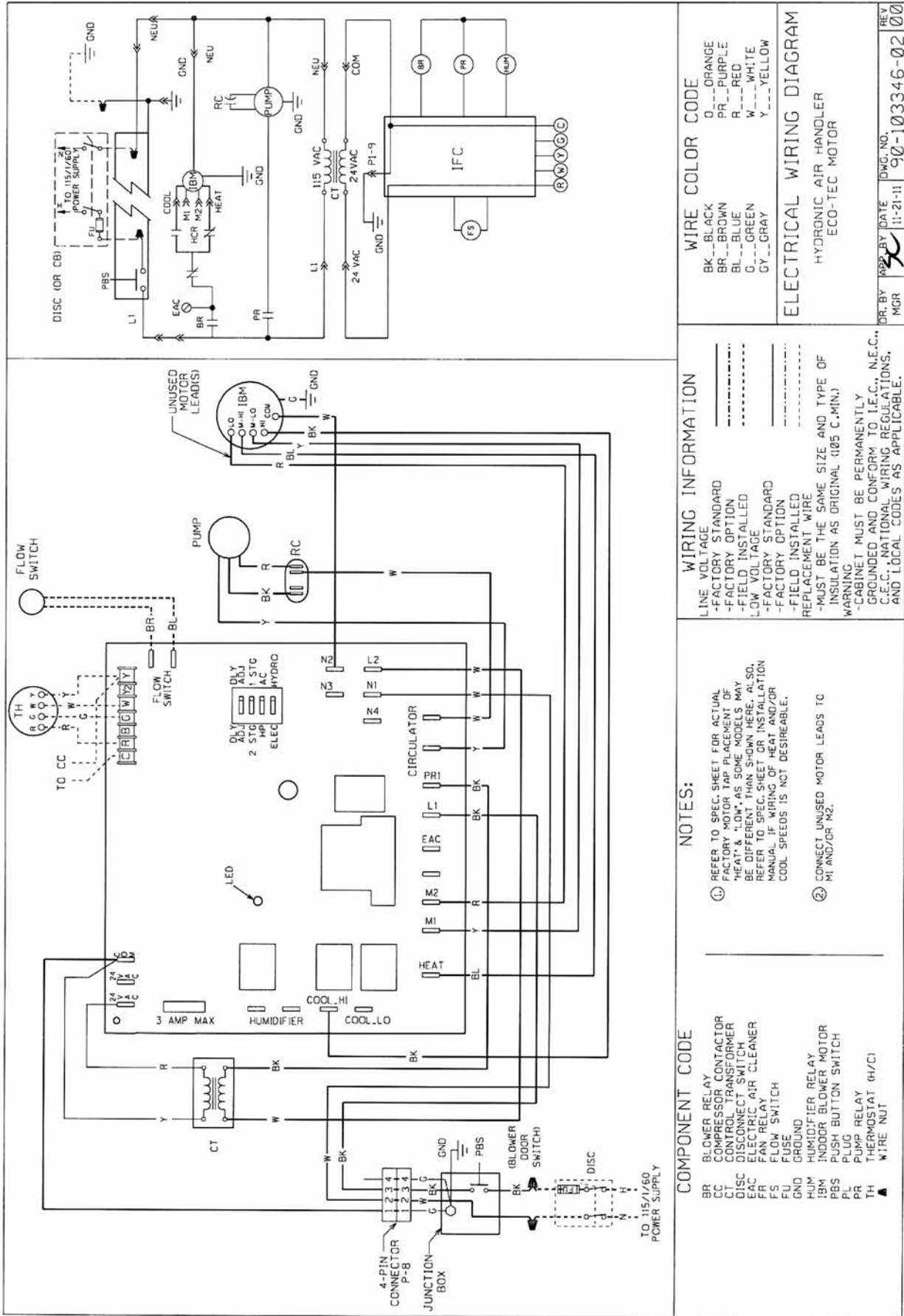

**WIRE COLOR CODE**

BK	BLACK
BR	BROWN
BL	BLUE
GR	GREEN
GY	GRAY
OR	ORANGE
PR	PURPLE
RD	RED
WH	WHITE
YL	YELLOW

**ELECTRICAL WIRING DIAGRAM**  
HYDRONIC AIR HANDLER  
ECO-TEC MOTOR

DR. BY: *[Signature]* DATE: 11-21-11 DWG. NO.: 90-103346-02 REV: 00

**WIRING INFORMATION**

LINE VOLTAGE  
 -FACTORY STANDARD  
 -FACTORY OPTION  
 -FIELD INSTALLED  
 LOW VOLTAGE  
 -FACTORY STANDARD  
 -FACTORY OPTION  
 -FIELD INSTALLED

REPLACEMENT WIRE  
 -MUST BE THE SAME SIZE AND TYPE OF INSULATION AS ORIGINAL (105 C.MIN.)  
 WARNING  
 -CABINET MUST BE PERMANENTLY GROUNDED AND CONFORM TO I.E.C., N.E.C., C.E.C., NATIONAL WIRING REGULATIONS, AND LOCAL CODES, AS APPLICABLE.

**NOTES:**

① REFER TO SPEC. SHEET FOR ACTUAL FACTORY MOTOR TAP PLACEMENT OF 'HEAT' & 'LOW', AS SOME MODELS MAY BE DIFFERENT THAN SHOWN HERE. ALSO, REFER TO SPEC. SHEET OR INSTALLATION MANUAL IF WIRING OF HEAT AND/OR COOL SPEEDS IS NOT DESIRABLE.

② CONNECT UNUSED MOTOR LEADS TO MI AND/OR M2.

**COMPONENT CODE**

BR	BLOWER RELAY
CC	COMPRESSOR CONTACTOR
CT	CONTROL TRANSFORMER
DISC	DISCONNECT SWITCH
EAC	ELECTRIC AIR CLEANER
FR	FAN RELAY
FS	FAN SWITCH
FU	FUSE
GND	GROUND
HUM	HUMIDIFIER
IBM	INDOOR BLOWER MOTOR
PBS	PUSH BUTTON SWITCH
PL	PLUG
PR	PUMP RELAY
TH	THERMOSTAT (H/C)
▲	WIRE NUT