



Model 98

Sump Pump

Professional Series Sump Pump Model 98 Features:

- 3-year warranty
- 2-pole mechanical switch
- 1/2 HP 115 V sump pump
- Performance up to 23' (7 m) TDH
- Flows up to 72 GPM (273 LPM)
- Cast iron switch case, base, motor and pump housing
- Corrosion-resistant, powder coated epoxy paint

100% factory tested



Trusted. Tested. Tough.®

zoellerpumps.com 800-928-7867
3649 Cane Run Road, Louisville, KY 40211 USA

FM3012

PRODUCT SPECIFICATIONS

MOTOR	Horse Power	1/2
	Voltage	115 or 230
	Phase	1 Ph
	Hertz	60 Hz
	RPM	1725
	Type	Permanent split capacitor
	Insulation	Class B
	Amps	4.7 - 9.4
PUMP	Operation	Automatic or nonautomatic
	Auto On/Off Points	9-1/2" (24 cm) / 3" (7.6 cm)
	Discharge Size	1-1/2" NPT
	Solids Handling	1/2" (13 mm) spherical solids
	Cord Length	15' (5 m) standard
	Cord Type	UL listed
	Max. Head	23' (7 m)
	Max. Flow Rate	72 GPM (273 LPM)
	Max. Operating Temp.	130° F (54° C)
	Cooling	Oil filled
	Motor Protection	Auto reset thermal overload
	MATERIALS	Cap
Motor Housing		Cast iron
Pump Housing		Cast iron
Base		Cast iron
Upper Bearing		Oil-fed cast iron
Lower Bearing		Oil-fed cast iron
Mechanical Seals		Carbon and ceramic
Impeller Type		Non-clogging vortex
Impeller		Engineered plastic
Hardware		Stainless steel
Motor Shaft		AISI 1215 cold rolled steel
Gasket		Neoprene

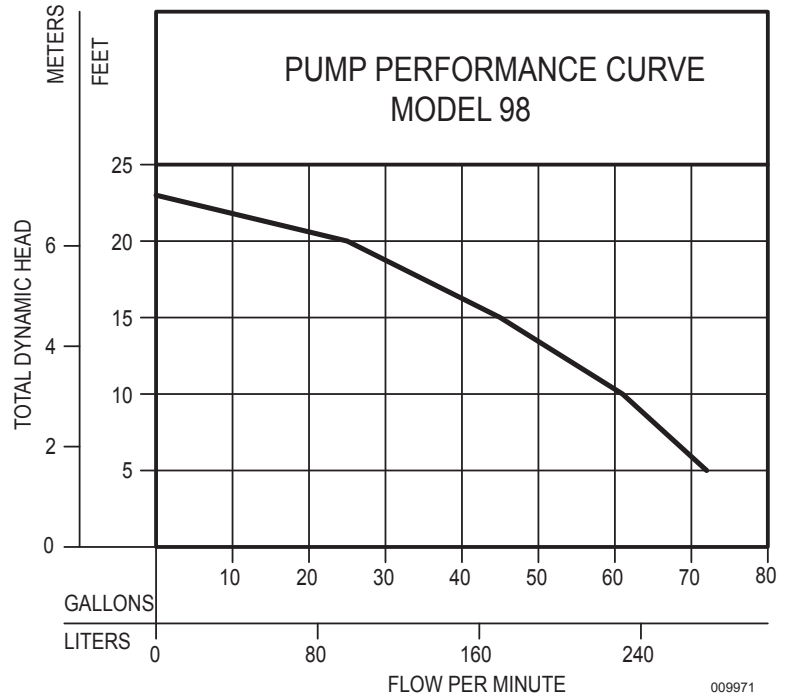
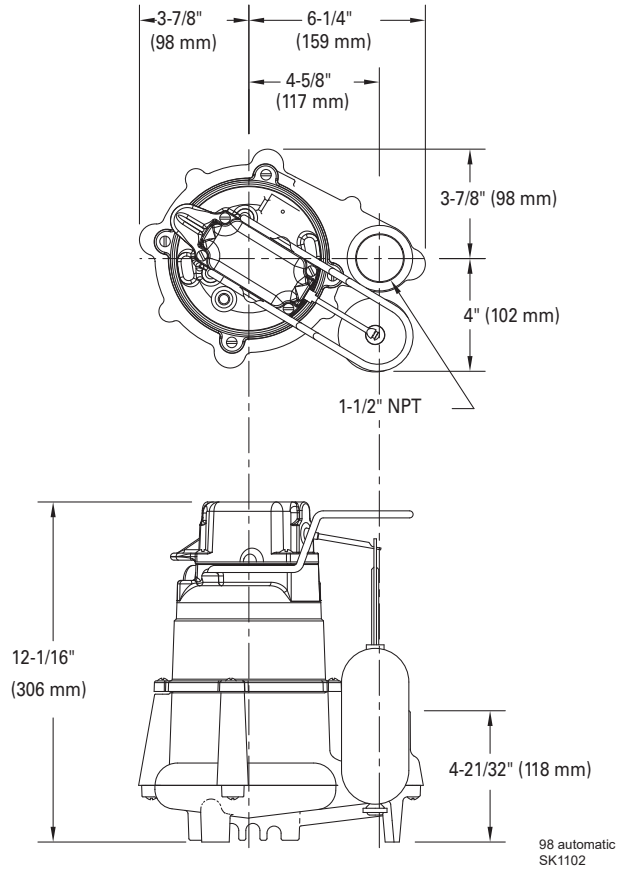



 Tested to Standard UL778 and
 Certified to CSA
 Standard C22.2 No. 108





009971