

# P-RH Heavy Commercial Roof Hydrants and Bracket



4515 East 139th Street  
Grandview, MO 64030  
(800) 362-9055  
Fax: (800) 362-1463

## Installation, Operation & Maintenance Instructions

The Prier Heavy Commercial Roof Hydrants provide a wide variety of installation options suitable for all types of roofs and structures.

The Prier Universal Roof Hydrant Mounting Bracket (P-RMB) attaches to a structural member of the building, not simply the skin of the building to provide a stronger, safer installation. Additionally, the hydrant is installed through a

small, single hole penetration in the roof, ensuring simple installation by a single tradesman and years of leak-free operation. The Prier design is adjustable for all types of roofs up to 4/12 pitch.

Depending on your chosen installation, standard building materials may be required, including Unistrut, threaded rod and additional fasteners.

## Typical Installations:

*Truss (Purlin) Installation*

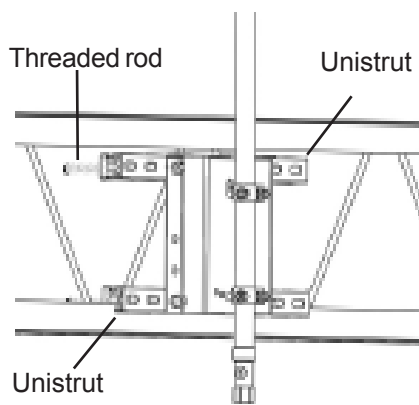

*I-Beam (Column) Installation*

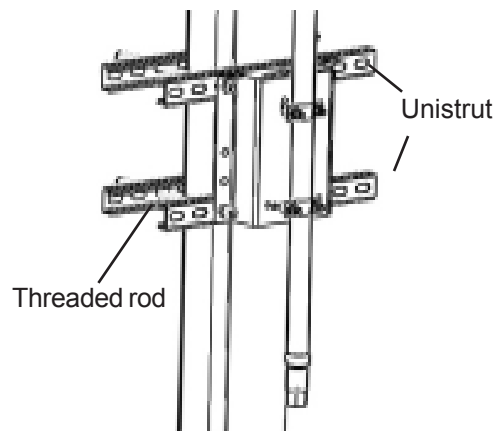

*Concrete Roof Installation*

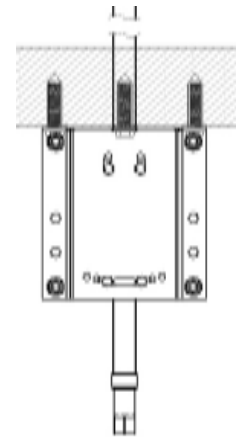

## Bracket Installation Instructions:

1. Select a location for the installation of your Prier Roof Hydrant. A good location typically has close proximity to any rooftop equipment requiring water and is near structural members under the roof and can be properly drained to water supply and drain.
2. Determine the type of installation you will use to install the Universal Roof Hydrant Mounting Bracket (P-RMB) to the structure of the building. Typical installations are shown above. The P-RMB can be installed to any of the structural supports on the building. (Some of these installations may require additional Unistrut, all-thread or fasteners.)
3. If mounting to a concrete roof, assure that the tabs are in the "UP" position.
4. Mount the P-RMB to the desired structure.

## Truss (Purlin) Instructions:

1. For a truss installation, you will need to use Unistrut and fasteners that are not provided with the Universal Roof Hydrant Mounting Bracket (P-RMB).
2. Cut two sections of Unistrut that are approximately 24" in length, making

## Rough-In Dimensions:

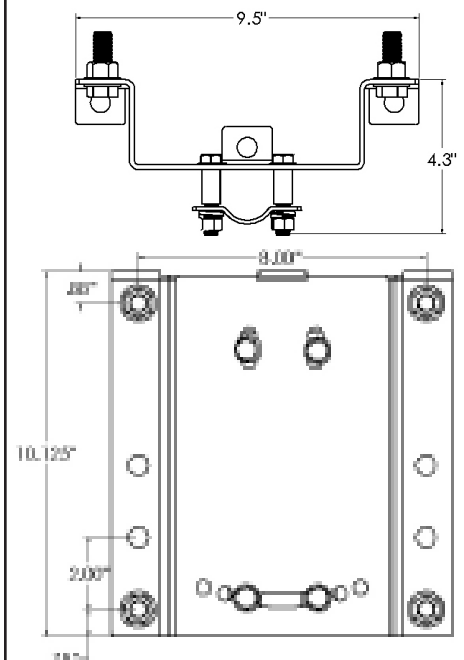

### **...continued - Truss (Purlin) Instructions:**

sure the Unistrut is long enough to cover enough of the webbing to ensure a secure connection. Using fasteners, sandwich the truss between the two pieces of Unistrut until secure.

3. Mount the P-RMB to the Unistrut with the fasteners provided.

### **I-Beam (Column) Instructions:**

1. For a column I-beam installation, you will need to use Unistrut, threaded rod, washers and nuts that are not provided with the Universal Roof Hydrant Mounting Bracket (P-RMB).
2. Cut two sections of Unistrut that are approximately 18" in length. Using the threaded rod, sandwich the I-beam between the two pieces of Unistrut until secure.
3. Mount the P-RMB to the Unistrut with the fasteners provided.

### **Concrete Roof Instructions:**

1. For a concrete roof, you will need 1/2" concrete wedge anchors, not provided with the Universal Roof Hydrant Mounting Bracket (P-RMB).
2. Using the top tabs on the P-RMB as a template, mark the concrete where the holes for the concrete wedge anchors should be drilled. Drill and install concrete wedge anchors per manufacturer instructions.
3. Mount the P-RMB to the wedge anchors installed in step two and torque to manufacturer requirements.

## **Hydrant Installation Instructions:**

1. Drill a 1 3/4" hole in the roof directly above the pipe brackets on the Universal Roof Hydrant Mounting Bracket (P-RMB). If necessary, use a laser pointer or scrap pipe through the pipe brackets to assure the hole is drilled in the proper location.
2. Install the hydrant from the rooftop through the hole drilled in step one and down through the pipe brackets in the P-RMB. Each hydrant has a measuring tape sticker affixed to the hydrant to assist in installation. The measuring tape begins at "roof level". You will need to take into account any insulation, pitch boxes or gravel when determining the height of the hydrant.
3. Secure the hydrant into the P-RMB by tightening the bolts on the pipe bracket.
4. If using a freezeless hydrant, there is a 1/8" drain port that will need to be piped away to a drain.

## **Roof Seal:**

The roof penetration should be sealed by the roofing contractor with acceptable roofing construction methods. Prier recommends either a poured in place pitch box or a leaded roof flashing, sealed by the roofing contractor, as they would for any other rooftop pipe penetrations.

## **Roof Pitch Options:**

In some occasions, the Roof Hydrant may need to be angled to match the roof or equipment configuration. That has been accounted for in the P-RMB.

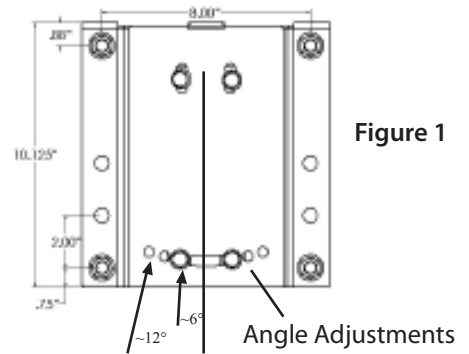

Figure 1

As shown above in Figure 1, you can adjust the angle of the roof hydrant by changing the position of the pipe bracket. Upon completion, the hydrant should be perpendicular to the floor for proper operation.

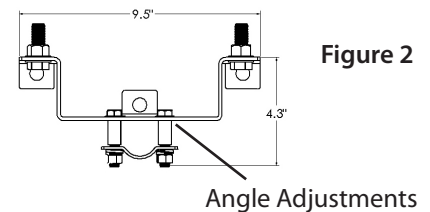

Figure 2

As shown above in Figure 2, you can adjust the angle of the roof hydrant in the other direction by stacking washers under the pipe support. Upon completion, the hydrant should be perpendicular to the floor for proper operation.

## **Maintenance:**

The Prier Roof Hydrants require no scheduled maintenance and will provide years of reliable service.