

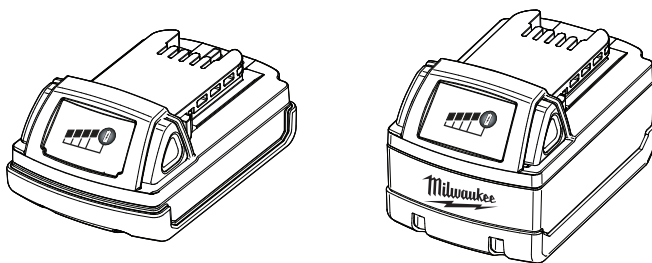

OPERATOR'S MANUAL
MANUEL de L'UTILISATEUR
MANUAL del OPERADOR

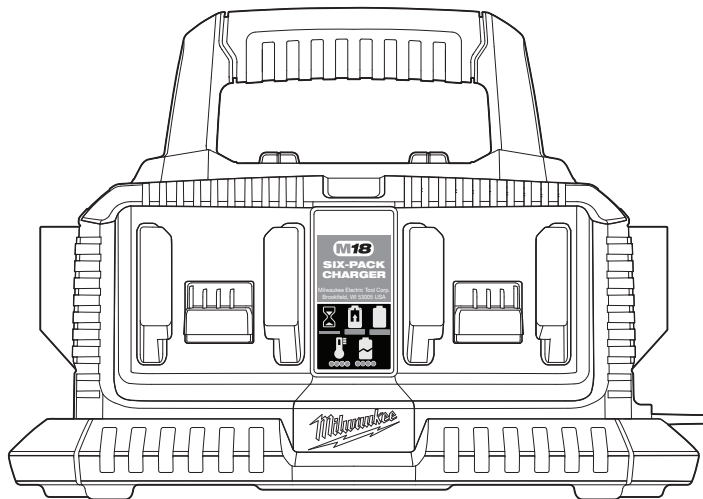



Cat. No. / No de cat.
48-59-1806

M18™ SIX-PACK CHARGER
M18™ LITHIUM-ION BATTERY PACKS
CHARGEUR À SIX BLOCS DE BATTERIES M18™
BLOCS DE BATTERIES LITHIUM-ION M18™
CARGADOR M18™ PARA SEIS BATERÍAS
BATERÍAS DE IONES DE LITIO M18™

New batteries must be charged before first use.

Les batteries neuves doivent être chargées avant leur utilisation initiale.

Las baterías nuevas se deben cargar antes de usarlas por primera vez.

 **WARNING** To reduce the risk of injury, user must read and understand operator's manual.
 **AVERTISSEMENT** Afin de réduire le risque de blessures, l'utilisateur doit lire et bien comprendre le manuel.
 **ADVERTENCIA** Para reducir el riesgo de lesiones, el usuario debe leer y entender el manual.

IMPORTANT SAFETY INSTRUCTIONS

AWARNING READ AND UNDERSTAND ALL INSTRUCTIONS. Failure to follow all instructions listed below, may result in electric shock, fire and/or serious personal injury.

SAVE THESE INSTRUCTIONS

- 1. SAVE THESE INSTRUCTIONS - THIS OPERATOR'S MANUAL CONTAINS IMPORTANT SAFETY AND OPERATING INSTRUCTIONS FOR MILWAUKEE LI-ION BATTERY PACKS AND THE MILWAUKEE LI-ION CHARGER.**
- 2. BEFORE USING THE BATTERY PACK AND CHARGER, READ THIS OPERATOR'S MANUAL, YOUR TOOL OPERATOR'S MANUAL, AND ALL LABELS ON THE BATTERY PACK, CHARGER AND TOOL.**
- 3. CAUTION TO REDUCE THE RISK OF INJURY, CHARGE MILWAUKEE M18™ LI-ION RECHARGEABLE PACKS ONLY IN THEIR MILWAUKEE LI-ION M18™ CHARGER.** Other types of chargers may cause personal injury or damage. Battery pack and charger are not compatible with V™-technology or NiCd systems. Do not wire a battery pack to a power supply plug or car cigarette lighter. Battery packs will be permanently disabled or damaged.
- 4. USE MILWAUKEE LI-ION PACKS ONLY ON COMPATIBLE MILWAUKEE LI-ION TOOLS.** Battery pack and charger are not compatible with V™-technology or NiCd systems. Use with other tools may result in a risk of fire, electric shock or personal injury.
- 5. AVOID DANGEROUS ENVIRONMENTS.** Do not charge battery pack in rain, snow, damp or wet locations. Do not use battery pack or charger in the presence of explosive atmospheres (gaseous fumes, dust or flammable materials) because sparks may be generated when inserting or removing battery pack, possibly causing fire.
- 6. CHARGE IN A WELL VENTILATED AREA.** Do not block charger vents. Keep them clear to allow proper ventilation. Do not allow smoking or open flames near a charging battery pack. Vented gases may explode.
- 7. MAINTAIN CHARGER CORD.** When unplugging charger, pull plug rather than cord to reduce the risk of damage to the electrical plug and cord. Never carry charger by its cord. Keep cord from heat, oil and sharp edges. Make sure cord will not be stepped on, tripped over or subjected to damage or stress. Do not use charger with damaged cord or plug. Have a damaged charger replaced immediately.
- 8. DO NOT USE AN EXTENSION CORD UNLESS IT IS ABSOLUTELY NECESSARY.** Using the wrong, damaged or improperly wired extension cord could result in the risk of fire and electrical shock. If an extension cord must be used, plug the charger into a properly wired 16 gauge or larger extension cord with pins that are the same number, size and shape as the pins on the charger. Make sure that the extension cord is in good electrical condition.
- 9. CHARGER IS RATED FOR 120 VOLT AC ONLY.** Charger must be plugged into an appropriate receptacle.
- 10. USE ONLY RECOMMENDED ATTACHMENTS.** Use of an attachment not recommended or sold by the battery charger or battery pack manufacturer may result in a risk of fire, electric shock or personal injury.
- 11. UNPLUG CHARGER** when not in use. Remove battery packs from unplugged chargers.
- 12. TO REDUCE THE RISK OF ELECTRIC SHOCK,** always unplug charger before cleaning or maintenance. Do not allow water to flow into AC/DC plug. Use a Ground Fault Circuit Interrupter (GFCI) to reduce shock hazards.
- 13. DO NOT BURN OR INCINERATE BATTERY PACKS.** Battery packs may explode, causing personal injury or damage. Toxic fumes and materials are created when battery packs are burned.
- 14. DO NOT CRUSH, DROP, OR DAMAGE** battery pack. Do not use a battery pack or charger that has received a sharp blow, been dropped, run over, or damaged in any way (e.g., pierced with a nail, hit with a hammer, stepped on).
- 15. DO NOT DISASSEMBLE.** Incorrect reassembly may result in the risk of electric shock, fire or exposure to battery chemicals. If it is damaged, take it to a MILWAUKEE service facility.
- 16. BATTERY CHEMICALS CAUSE SERIOUS BURNS.** Never allow contact with skin, eyes, or mouth. If a damaged battery pack leaks battery chemicals, use rubber or neoprene gloves to dispose of it. If skin is exposed to battery fluids, wash with soap and water and rinse with vinegar. If eyes are exposed to battery chemicals, immediately flush with water for 20 minutes and seek medical attention. Remove and dispose of contaminated clothing.
- 17. DO NOT SHORT CIRCUIT.** A short-circuited battery pack may cause fire, personal injury, and product damage. A battery pack will short circuit if a metal object makes a connection between the positive and negative contacts on the battery pack. Do not place a battery pack near anything that may cause a short circuit, such as coins, keys or nails in your pocket.
- 18. DO NOT ALLOW FLUIDS TO FLOW INTO BATTERY PACK.** Corrosive or conductive fluids, such as seawater, certain industrial chemicals, and bleach or bleach containing products, etc., can cause a short circuit..
- 19. STORE YOUR BATTERY PACK AND CHARGER** in a cool, dry place. Do not store battery pack where temperatures may exceed 120°F (50°C) such as in direct sunlight, a vehicle or metal building during the summer.
- 20. ALWAYS USE A SIDE HANDLE** when using a HIGH OUTPUT or HIGH DEMAND battery pack 6.0 Ah or above; the output torque of some tools may increase. If your drill/driver did not come with a side handle, visit www.milwaukeetool.com for the appropriate accessory handle.

FUNCTIONAL DESCRIPTION

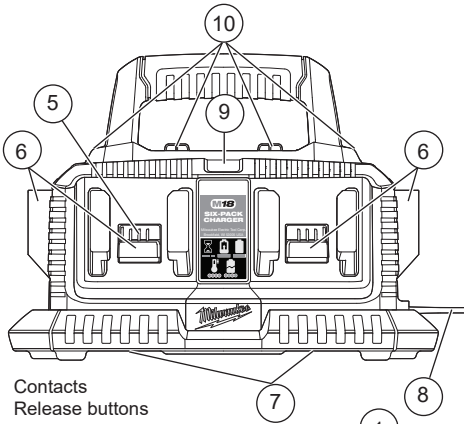

1. Contacts
2. Release buttons
3. Fuel Gauge button
4. Fuel Gauge
5. Electrical contacts
6. Bays
7. Vents
8. Cord
9. Skip button
10. Light indicators:

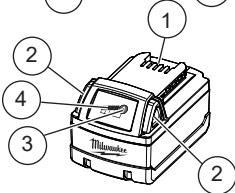

- Continuous red: Charging
- Continuous green light: Charging is complete
- Fast flashing red: Battery is too hot/cold - Charging will begin when battery reaches correct charging temperature
- Slow flashing red: Battery charge is pending - Charging will begin when the first pack is fully charged
- Flashing red/green: Damaged or faulty battery pack

SYMBOLOLOGY

- Volts
- Direct Current
- Alternating Current
- Double Insulated
- Properly Recycle Batteries
- Hertz
- Amps
- UL Listing for Canada and U.S.

SPECIFICATIONS

- Cat. No. 48-59-1806
- Input Volts 120 AC
- Input Amps 2.1 AC
- Output Volts 18 DC
- Output Amps 3.5 DC
- Recommended Ambient
Charging Temperature 40°F to 105°F
- M18™ Li-Ion Battery Packs 18 V DC

MILWAUKEE M18™ LI-ION BATTERY PACKS

Fuel Gauge

Use the Fuel Gauge to determine the battery pack's remaining run time. Press the Fuel Gauge button to display the lights. The Fuel Gauge will light up for 2-3 seconds. When less than 10% of charge is left, 1 light on the fuel gauge will flash slowly.

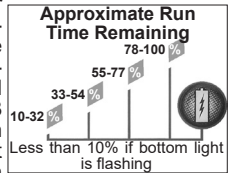

NOTE: If the Fuel Gauge doesn't appear to be working, place the battery pack on the charger and charge as needed.

Compared to NiCd battery pack types, MILWAUKEE Li-Ion battery packs deliver fade-free power for their entire run time. The tool will not experience a slow, gradual loss of power as you work. To signal the end of discharge, 1 light on the fuel gauge will flash quickly for 2-3 seconds and the tool will not run. Charge the battery pack.

NOTE: Immediately after using the battery pack, the Fuel Gauge may display a lower charge than it will if checked a few minutes later. The battery cells "recover" some of their charge after resting.

Battery Pack Protection

To protect itself from damage and extend its life, the battery pack's intelligent circuit monitors current draw and temperature. In extremely high torque, binding, stalling, and short circuit situations, the battery pack will turn OFF the tool if the current draw becomes too high. All the fuel gauge lights will flash. Release the trigger and restart.

Under extreme circumstances, the internal temperature of the battery could become too high. If this happens, the fuel gauge lights will flash in an alternating pattern and the tool will not run. Allow the battery to cool down.

Fuel Gauge Lights	Diagnosis	Solution
Lights 1 - 4 Solid	Remaining run time	Continue working
1 Light, flashing slowly	Less than 10% run time left	Prepare to charge pack
1 Light, flashing quickly	End of discharge	Charge pack
Lights 1-4, flashing quickly	Current draw too high	Release trigger and restart, reduce pressure
Lights 1&3 / 2&4, flashing alternately	Battery temperature too high	Release trigger and allow battery to cool

Cold Weather Operation

MILWAUKEE Li-Ion battery packs are designed to operate in temperatures below freezing. When the battery pack is too cold, it may need to warm up before normal use. Put the battery on a tool and use the tool in a light application. It may "buzz" for a short time until it warms up. When the buzzing stops, use the tool normally.

⚠WARNING To reduce the risk of fire, personal injury, and product damage due to a short circuit, never immerse your tool, battery pack or charger in fluid or allow a fluid to flow inside them. Corrosive or conductive fluids, such as seawater, certain industrial chemicals, and bleach or bleach containing products, etc., can cause a short circuit.

Maintenance and Storage

Do not expose your battery pack or cordless tools to water or rain, or allow them to get wet. This could damage the tool and battery pack. Do not use oil or solvents to clean or lubricate your battery pack. The plastic casing will become brittle and crack, causing a risk of injury.

Store battery packs at room temperature away from moisture. Do not store in damp locations where corrosion of terminals may occur. As with other battery pack types, permanent capacity loss can result if the pack is stored for long periods of time at high temperatures (over 120° F). MILWAUKEE Li-Ion battery packs maintain their charge during storage longer than other battery pack types. After about a year of storage, charge the pack as normal.

Transport

Personal transport of Li-Ion battery packs is allowed when done in accordance with these warnings and instructions. The proper classification, packaging, labeling, marking, and documentation requirements for shipping Li-Ion batteries is dependent upon whether the particular batteries are rated greater than or less than 100 Wh. Generally, Li-Ion batteries rated 100 Wh or less are "excepted" from certain Class 9 DG requirements. Always check compliance of Li-Ion battery consignments against the current regulations governing the chosen mode of transport. When in doubt, contact the carrier or other trained Dangerous Goods professional to confirm acceptability. Li-Ion packs are shipped under classification UN 3480 (battery only) or UN 3481 (batteries contained in or packed with equipment).

⚠WARNING To reduce the risk of injury or explosion, never burn or incinerate a battery pack even if it is damaged, dead or completely discharged. When burned, toxic fumes and materials are created.

Disposing of MILWAUKEE Li-Ion Battery Packs

MILWAUKEE Li-Ion battery packs are more environmentally friendly than some other types of power tool battery packs (e.g., nickel-cadmium). Always dispose of your battery pack according to federal, state and local regulations. Contact a recycling agency in your area for recycling locations.

Even discharged battery packs contain some energy. Before disposing, use electrical tape to cover the terminals to prevent the battery pack from shorting, which could cause a fire or explosion.

RBRC Battery Recycling Seals

The RBRC™ Battery Recycling Seals (see "Symbolology") on your tool battery packs indicate that MILWAUKEE has arranged for the recycling of that battery pack with the Rechargeable Battery Recycling Corporation (RBRC). At the end of your battery pack's useful life, return the battery pack to a MILWAUKEE Branch Office/Service Center or the participating retailer nearest you. For more information, visit the RBRC web site at www.rbrc.org.

MILWAUKEE M18™ SIX-PACK CHARGER

⚠WARNING Charge only MILWAUKEE M18™ Li-Ion batteries in this MILWAUKEE Li-Ion charger. Other types of batteries may cause personal injury and damage.

When to Charge the Battery Pack with this MILWAUKEE Charger

Remove the battery pack from the tool for charging when convenient for you and your job. MILWAUKEE batteries do not develop a "memory" when charged after only a partial discharge. It is not necessary to run down the battery pack before placing it on the charger.

- Use the Fuel Gauge to determine when to charge your MILWAUKEE Li-Ion battery pack.
- You can "Top-Off" your battery pack's charge before starting a big job or long day of use.
- The only time it is necessary to charge the MILWAUKEE Li-Ion battery pack is when the battery pack has reached the end of its charge. To signal the end of charge, power to the tool will drop quickly, allowing you just enough power to finish making a cut, drilling a hole, or driving a fastener. Charge the battery pack as needed.

How to Charge the Battery Pack

Align the battery pack with the bay and slide the battery pack into the charger as far as possible. The red light will come on, either flashing quickly (battery pack is too hot or cold), flashing slowly (battery pack is waiting for another pack to finish charging) or continuous (pack is charging).

- The 48-59-1806 charges six batteries in sequence in a counter-clockwise rotation.
- The next pack inserted in the charger will begin charging when the previous pack is fully charged. To skip a pack and move to the next pack, press the skip button ►.
- A fully discharged battery pack with an internal temperature in the normal range will charge in 30 to 185 minutes, depending on the battery pack.
- Heavily cycled batteries may take longer to charge completely.
- The Fuel Gauge lights on 18V battery packs are displayed as the pack is being charged, indicating how fully charged the pack is. The fuel gauge will turn off when charging is complete.
- After charging is complete, the continuous green light will come on.
- The charger will keep the battery pack fully charged if it is left on the charger.
- If the light indicator flashes red and green, check that the battery pack is fully seated into the bay.

Remove the battery pack and reinsert. If the light continues to flash red and green, remove pack(s) and unplug charger for at least 2 minutes. After 2 minutes, plug charger back in and insert pack. If the problem persists, contact a MILWAUKEE service facility.

- If the light indicator does not come on, check that the battery pack is fully seated into the bay. Remove the battery pack and reinsert. If the light indicator still does not come on, remove pack(s) and unplug charger for at least 2 minutes. After 2 minutes, plug charger back in and insert pack. If after these attempts the light indicator still does not come on, contact a MILWAUKEE service facility.

Charging a Hot or Cold Battery Pack

The Red Flashing Indicator light on the charger indicates that the battery pack temperature is outside the charging range. Once the battery pack is within the acceptable range, normal charging will take place and the red light will be continuous. Hot or cold batteries may take longer to charge.

Li-Ion Charging Status

Battery Pack Temperature	Red Charger Indicator Light	Charging Status
Too Hot	Fast Flashing	Not charging
Normal Range	Continuous	Normal charging
Too Cold	Fast Flashing	Not charging

Powering the Charger with an Inverter or Generator

The charger will operate with most generators and inverters rated at 300 Watts or higher.

Maintenance and Storage

Store your charger in a cool, dry place. As a general practice, it is best to unplug battery chargers and remove batteries when not in use. No battery pack damage will occur, however, if the charger and battery pack are left plugged in.

WARNING To reduce the risk of injury, always unplug the charger and remove the battery from the charger before performing any maintenance. Never disassemble the battery or charger. Contact a MILWAUKEE service facility for ALL repairs.

To reduce the risk of injury and damage, never immerse your battery or charger in liquid or allow a liquid to flow inside them.

Cleaning

Clean out dust and debris from charger vents and electrical contacts by blowing with compressed air. Use only mild soap and a damp cloth to clean the battery pack and charger, keeping away from all electrical contacts. Certain cleaning agents and solvents are harmful to plastics and other insulated parts. Some of these include gasoline, turpentine, lacquer thinner, paint thinner, chlorinated cleaning solvents, ammonia and household detergents containing ammonia. Never use flammable or combustible solvents around batteries, charger, or tools.

Repairs

The charger has no serviceable parts.

SERVICE - UNITED STATES

1-800-SAWDUST (1.800.729.3878)

Monday-Friday, 7:00 AM - 6:30 PM CST

or visit www.milwaukeetool.com

Contact Corporate After Sales Service Technical Support with technical, service/repair, or warranty questions.

Email: metproductsupport@milwaukeetool.com

Become a Heavy Duty Club Member at www.milwaukeetool.com to receive important notifications regarding your tool purchases.

SERVICE - CANADA

Milwaukee Tool (Canada) Ltd

1.800.268.4015

Monday-Friday, 7:00 AM - 4:30 PM CST

or visit www.milwaukeetool.ca

LIMITED WARRANTY USA & CANADA

Every MILWAUKEE Battery Pack (sold with cordless product and/or as a replacement battery pack) is warranted to the original purchaser only to be free from defects in material and workmanship. Subject to certain exceptions, MILWAUKEE will repair or replace a battery pack which, after examination, is determined by MILWAUKEE to be defective in material or workmanship for the stated warranty period from date of purchase. Return of the battery pack to a MILWAUKEE factory Service Center location or MILWAUKEE Authorized Service Station, freight prepaid and insured, is required. For the proper shipping procedure of battery packs, contact 1.800.SAWDUST (1.800.729.3878), or go to www.milwaukeetool.com. A copy of the proof of purchase should be included with the return product. This warranty does not apply to damage that MILWAUKEE determines to be from repairs made or attempted by anyone other than MILWAUKEE authorized personnel, misuse, alterations, abuse, normal wear and tear, lack of maintenance, or accidents.

Battery Pack Cat. No.	Chemistry	Warranty Period (from date of purchase)
48-11-1812, 48-11-1828 (Serial number prefix "B41E" and later), 48-11-1840, 48-11-1850, 48-11-1860, 48-11-1865, 48-11-1880, 48-11-1890, 48-11-2402, 48-11-2440, 48-11-2460, 48-11-2630 (Serial number prefix "C71")	Lithium-Ion (Li-Ion)	Three (3) Years
48-11-0490, 48-11-1815, 48-11-1820, 48-11-1835, 48-11-2001, 48-11-2401, 48-11-2420, 48-11-2430	Lithium-Ion (Li-Ion)	Two (2) Years
48-11-1828 (Serial number prefix "B41D" and earlier), 48-11-1830 (Serial number prefix "A95"), 48-11-2630 (Serial number prefix "A71")	Lithium-Ion (Li-Ion)	Two (2) Years – plus, Three (3) Years Pro-Rata (prorated)
48-11-0100, 48-11-1024, 48-11-1830 (Serial number prefix "E95"), 48-11-1970, 48-11-2230	Nickel-Cadmium (Ni-Cd), Nickel-Metal-Hydrate (Ni-MH), Lithium-Ion (Li-Ion)	One (1) Year

*The warranty period for MILWAUKEE M18™ 48-11-1828 (with the serial number prefix "B41D" and earlier), V18™ 48-11-1830 (with the serial number prefix "A95"), and V28™ 48-11-2630 (with the serial number prefix "A71") is five (5) years / 2000 charges from the date of purchase, whichever first occurs. The first 1000 charges or 2 years of the warranty, whichever first occurs, are covered through free replacement of the defective battery. This means that for the earlier of the first 1000 charges or two (2) years from the date of purchase/first charge, a replacement battery will be provided to the customer for any defective battery free of charge. Thereafter, the remaining charges up to a total of 2000 or the remainder of the five (5) year period from the date of purchase, whichever first occurs, will be covered on a pro rata basis. This means that every customer gets an additional 1000 charges or three (3) years of pro rata warranty on the these battery packs, depending upon the amount of use. MILWAUKEE M18™ 48-11-1828 (with the serial number prefix "B41E" and later), V18™ 48-11-1830 (with the serial number prefix "E95"), and M28™ 48-11-2830 (with the serial number prefix "C71") have different warranty periods, as listed.

Warranty Registration is not necessary to obtain the applicable warranty on a MILWAUKEE battery pack. The manufacturing date of the product will be used to determine the warranty period if no proof of purchase is provided at the time warranty service is requested.

ACCEPTANCE OF THE EXCLUSIVE REPAIR AND REPLACEMENT REMEDIES DESCRIBED IS THE REINIS CONDITION OF THE CONTRACT FOR THE PURCHASE OF EVERY MILWAUKEE PRODUCT. IF YOU DO NOT AGREE TO THIS CONDITION, YOU SHOULD NOT PURCHASE THE PRODUCT. IN NO EVENT SHALL MILWAUKEE BE LIABLE FOR ANY INCIDENTAL, SPECIAL, CONSEQUENTIAL OR PUNITIVE DAMAGES, OR FOR ANY COSTS, ATTORNEY FEES, EXPENSES, LOSSES OR DELAYS ALLEGED TO BE AS A CONSEQUENCE OF ANY DAMAGE TO, FAILURE OF, OR DEFECT IN ANY PRODUCT INCLUDING, BUT NOT LIMITED TO, ANY CLAIMS FOR LOSS OF PROFITS. SOME STATES DO NOT ALLOW US TO LIMIT OR LIMITATION OF INCIDENTAL OR CONSEQUENTIAL DAMAGES, SO THE ABOVE LIMITATION OR EXCLUSION MAY NOT APPLY TO YOU. THIS WARRANTY IS EXCLUSIVE AND IN LIEU OF ALL OTHER EXPRESS WARRANTIES, WRITTEN OR ORAL. TO THE EXTENT PERMITTED BY LAW, MILWAUKEE DISCLAIMS ANY IMPLIED WARRANTIES, INCLUDING WITHOUT LIMITATION ANY IMPLIED WARRANTY OF MERCHANTABILITY OR FITNESS FOR A PARTICULAR USE OR PURPOSE. TO THE EXTENT SUCH DISCLAIMER IS NOT PERMITTED BY LAW, SUCH IMPLIED WARRANTIES ARE LIMITED TO THE

DURATION OF THE APPLICABLE EXPRESS WARRANTY AS DESCRIBED ABOVE. SOME STATES DO NOT ALLOW LIMITATIONS ON HOW LONG AN IMPLIED WARRANTY LASTS, SO THE ABOVE LIMITATION MAY NOT APPLY TO YOU, THIS WARRANTY GIVES YOU SPECIFIC LEGAL RIGHTS, AND YOU MAY ALSO HAVE OTHER RIGHTS WHICH VARY FROM STATE TO STATE. This warranty applies to product sold in the U.S.A. and Canada only. Please consult the "Service Center Search" in the Parts & Service section of MILWAUKEE's website www.milwaukeeetool.com or call 1.800.SAWDUST (1.800.729.3878) to locate your nearest service facility for warranty and non-warranty service on a MILWAUKEE Battery Pack.

LIMITED WARRANTY USA & CANADA

Every MILWAUKEE power tool* (see exceptions below) is warranted to the original purchaser only to be free from defects in material and workmanship. Subject to certain exceptions, MILWAUKEE will repair or replace any part on an electric power tool which, after examination, is determined by MILWAUKEE to be defective in material or workmanship for a period of five (5) years** after the date of purchase unless otherwise noted. Return of the power tool to a MILWAUKEE factory Service Center location or MILWAUKEE Authorized Service Station, freight prepaid and insured, is required. A copy of the proof of purchase should be included with the return product. This warranty does not apply to damage that MILWAUKEE determines to be from repairs made or attempted by anyone other than MILWAUKEE authorized personnel, misuse, alterations, abuse, normal wear and tear, lack of maintenance, or accidents.

Normal Wear: Many power tools need periodic parts replacement and service to achieve best performance. This warranty does not cover repair when normal use has exhausted the life of a part including, but not limited to, chucks, brushes, cords, saw shoes, blade clamps, o-rings, seals, bumpers, driver blades, pliers, strikers, lifters, and bumper cover washers. *This warranty does not cover Air Nailers & Staplers; Airless Paint Sprayer; Cordless Battery Packs; Gasoline Driven Portable Power Generators; Hand Tools; Hoist - Electric, Lever & Hand Chain; M12™ Heated Gear; Reconditioned Product; and Test & Measurement Products. There are separate and distinct warranties available for these products.

**The warranty period for Job Site Radios, M12™ Power Port, M18™ Power Source, Jobsite Fan and Trade Titan™ Industrial Work Carts is one (1) year from the date of purchase. The warranty period for the Drain Cleaning Cables is two (2) years from the date of purchase. The warranty period for the M18™ Compact Heat Gun and the 8 Gallon Dust Extractor is three (3) years from the date of purchase. The warranty period for the LED in the LED Work Light and the LED Upgrade Bulb for the Work Light is the lifetime of the product subject to the limitations above. If during normal use the LED or LED Bulb fails, the part will be replaced free of charge.

Warranty Registration is not necessary to obtain the applicable warranty on a MILWAUKEE power tool product. The manufacturing date of the product will be used to determine the warranty period if no proof of purchase is provided at the time warranty service is requested.

ACCEPTANCE OF THE EXCLUSIVE REPAIR AND REPLACEMENT REMEDIES DESCRIBED HEREIN IS A CONDITION OF THE CONTRACT FOR THE PURCHASE OF EVERY MILWAUKEE PRODUCT. IF YOU DO NOT AGREE TO THIS CONDITION, YOU SHOULD NOT PURCHASE THE PRODUCT. IN NO EVENT SHALL MILWAUKEE BE LIABLE FOR ANY INCIDENTAL, SPECIAL, CONSEQUENTIAL OR PUNITIVE DAMAGES, OR FOR ANY COSTS, ATTORNEY FEES, EXPENSES, LOSSES OR DELAYS OR LEGAL FEES AS A CONSEQUENCE OF ANY DAMAGE TO, FAILURE OF OR DEFECT IN ANY PRODUCT INCLUDING, BUT NOT LIMITED TO, ANY CLAIMS FOR LOSS OF PROFITS. SOME STATES DO NOT ALLOW THE EXCLUSION OR LIMITATION OF INCIDENTAL OR CONSEQUENTIAL DAMAGES, SO THE ABOVE LIMITATION OR EXCLUSION MAY NOT APPLY TO YOU. THIS WARRANTY IS EXCLUSIVE AND IN LIEU OF ALL OTHER EXPRESS WARRANTIES, WRITTEN OR ORAL, TO THE EXTENT PERMITTED BY LAW, MILWAUKEE DISCLAIMS ALL WARRANTIES, INCLUDING WITHOUT LIMITATION ANY IMPLIED WARRANTY OF MERCHANTABILITY OR FITNESS FOR A PARTICULAR USE OR PURPOSE; TO THE EXTENT SUCH DISCLAIMER IS NOT PERMITTED BY LAW, SUCH IMPLIED WARRANTIES ARE LIMITED TO THE DURATION OF THE APPLICABLE EXPRESS WARRANTY AS DESCRIBED ABOVE. SOME STATES DO NOT ALLOW LIMITATIONS ON HOW LONG AN IMPLIED WARRANTY LASTS, SO THE ABOVE LIMITATION MAY NOT APPLY TO YOU, THIS WARRANTY GIVES YOU SPECIFIC LEGAL RIGHTS, AND YOU MAY ALSO HAVE OTHER RIGHTS WHICH VARY FROM STATE TO STATE.

This warranty applies to product sold in the U.S.A. and Canada only. Please consult the "Service Center Search" in the Parts & Service section of MILWAUKEE's website www.milwaukeeetool.com or call 1.800.SAWDUST (1.800.729.3878) to locate your nearest service facility for warranty and non-warranty service on a Milwaukee electric power tool.

LIMITED WARRANTY - MEXICO, CENTRAL AMERICA & CARIBBEAN

TECHTRONIC INDUSTRIES' warranty is for 5 years since the original purchase date.

This warranty card covers any defect in material and workmanship on this Product.

To make this warranty valid, present this warranty card, sealed/stamped by the distributor or store where you purchased the product, to the Authorized Service Center (ASC). Or, if this card has not been sealed/stamped, present the original proof of purchase to the ASC. Call 55 4160-3547 to find the nearest ASC, for service, parts, accessories or components.

Procedure to make this warranty valid

Take the product to the ASC, along with the warranty card sealed/stamped by the distributor or store where you purchased the product, and any faulty piece or component will be replaced without cost for you. We will cover all freight costs relative with this warranty process.

Exceptions

This warranty is not valid in the following situations
a) When the product is used in a different manner from the end-user guide or instruction manual.

b) When the conditions of use are not normal.

c) When the product was modified or repaired by people not authorized by TECHTRONIC INDUSTRIES.

Note: If cord set is damaged, it should be replaced by an Authorized Service Center to avoid electric risks.

SERVICE AND ATTENTION CENTER
Call to 55 4160-3547

IMPORTED AND COMMERCIALIZED BY
TECHTRONIC INDUSTRIES MEXICO, S.A. DE C.V.
Miguel de Cervantes Saavedra No.301 Piso 5, Torre Norte
11520 Colonia Ampliación Granada
Miguel Hidalgo, Ciudad de Mexico, Mexico

Model: _____

Date of Purchase: _____

Distributor or Store Stamp: _____

RÈGLES GÉNÉRALES DE SÉCURITÉ

AVERTISSEMENT LIRE ET COMPRENDRE TOUTES LES INSTRUCTIONS. Le non-respect des instructions ci-après peut entraîner des chocs électriques, des incendies et/ou des blessures graves.

CONSERVER CES INSTRUCTIONS

- 1. CONSERVER CES INSTRUCTIONS - CE MANUEL CONTIENT DES INFORMATIONS IMPORTANTES AU SUJET DE LA SÉCURITÉ ET DE L'UTILISATION DE L'ENSEMBLE CHARGEUR LI-ION MILWAUKEE ET BATTERIES LI-ION MILWAUKEE.**
- 2. AVANT D'UTILISER LE CHARGEUR ET LA BATTERIE, LIRE TOUTES LES INSTRUCTIONS DE SÉCURITÉ ET MISES EN GARDE FIGURANT SUR LE CHARGEUR DE BATTERIE, LA BATTERIE ET L'OUTIL.**
- 3. ATTENTION POUR RÉDUIRE LE RISQUE DE BLESSURE, CHARGER LES BATTERIES LI-ION MILWAUKEE M18™ UNIQUEMENT DANS LES CHARGEURS AU LI-ION MILWAUKEE M18™.** Les batteries d'autres types peuvent exploser et causer des dommages et blessures. Ne pas relier un bloc de batterie à une prise secteur ou un allume-cigare. Les batteries seront constamment désactivées ou endommagées.
- 4. UTILISER LES BLOCS DE BATTERIES AU LI-ION MILWAUKEE SUR LES OUTILS LI-ION MILWAUKEE COMPATIBLES.** Le bloc de batterie et le chargeur ne sont pas compatibles avec la technologie V™ ni les systèmes NiCd. L'utilisation avec d'autres outils peut causer un risque d'incendie, de choc électrique ou de blessures.
- 5. ÉVITEZ LES ENVIRONNEMENTS À RISQUES. N'UTILISEZ PAS LE CHARGEUR SOUS LA PLUIE, la neige ou dans les endroits humides ou mouillés.** Ne vous servez pas du chargeur ou de la batterie en milieu explosifs (émanations de gaz, poussière ou substances inflammables), car il pourrait se produire des étincelles, lors de l'insertion de la batterie dans le chargeur ou lors de son retrait, créant un risque d'incendie.