

### Submittal Data:

Maximum Inlet Pressure: 250 psi  
Adjustment Range: 10 – 50 psi  
Maximum Temperature: 210°F  
Factory Setting: 12 psi  
Media: Water

### Materials of Construction:

Body Forged Brass  
Cartridge Wetted Parts Stainless Steel,  
Engineered Plastics,  
Bronze, EPDM Seals

### Replacement Cartridge:

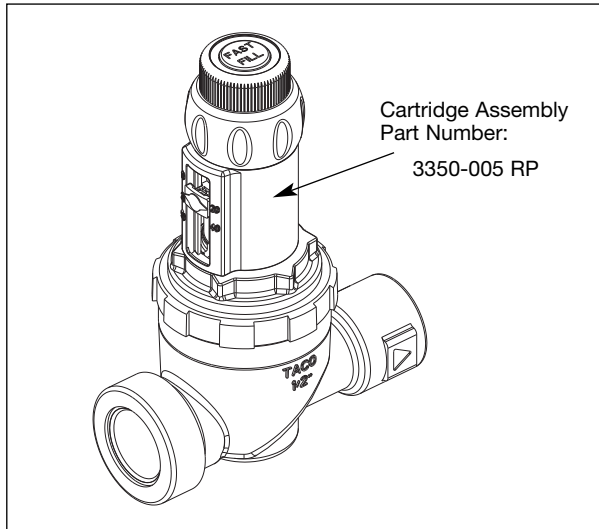

### LIMITED WARRANTY STATEMENT

Taco, Inc. will repair or replace without charge (at the company's option) any product or part which is proven defective under normal use within one (1) year from the date of start-up or one (1) year and six (6) months from date of shipment (whichever occurs first).

In order to obtain service under this warranty, it is the responsibility of the purchaser to promptly notify the local Taco stocking distributor or Taco in writing and promptly deliver the subject product or part, delivery prepaid, to the stocking distributor. For assistance on warranty returns, the purchaser may either contact the local Taco stocking distributor or Taco. If the subject product or part contains no defect as covered in this warranty, the purchaser will be billed for parts and labor charges in effect at time of factory examination and repair.

Any Taco product or part not installed or operated in conformity with Taco instructions or which has been subject to misuse, misapplication, the addition of petroleum-based fluids or certain chemical additives to the systems, or other abuse, will not be covered by this warranty.

If in doubt as to whether a particular substance is suitable for use with a Taco product or part, or for any application restrictions, consult the applicable Taco instruction sheets or contact Taco at [401-942-8000].

Taco reserves the right to provide replacement products and parts which are substantially similar in design and functionally equivalent to the defective product or part. Taco reserves the right to make changes in details of design, construction, or arrangement of materials of its products without notification.

**TACO OFFERS THIS WARRANTY IN LIEU OF ALL OTHER EXPRESS WARRANTIES. ANY WARRANTY IMPLIED BY LAW INCLUDING WARRANTIES OF MERCHANTABILITY OR FITNESS IS IN EFFECT ONLY FOR THE DURATION OF THE EXPRESS WARRANTY SET FORTH IN THE FIRST PARAGRAPH ABOVE.**

**THE ABOVE WARRANTIES ARE IN LIEU OF ALL OTHER WARRANTIES, EXPRESS OR STATUTORY, OR ANY OTHER WARRANTY OBLIGATION ON THE PART OF TACO.**

**TACO WILL NOT BE LIABLE FOR ANY SPECIAL, INCIDENTAL, INDIRECT OR CONSEQUENTIAL DAMAGES RESULTING FROM THE USE OF ITS PRODUCTS OR ANY INCIDENTAL COSTS OF REMOVING OR REPLACING DEFECTIVE PRODUCTS.**

This warranty gives the purchaser specific rights, and the purchaser may have other rights which vary from state to state. Some states do not allow limitations on how long an implied warranty lasts or on the exclusion of incidental or consequential damages, so these limitations or exclusions may not apply to you.

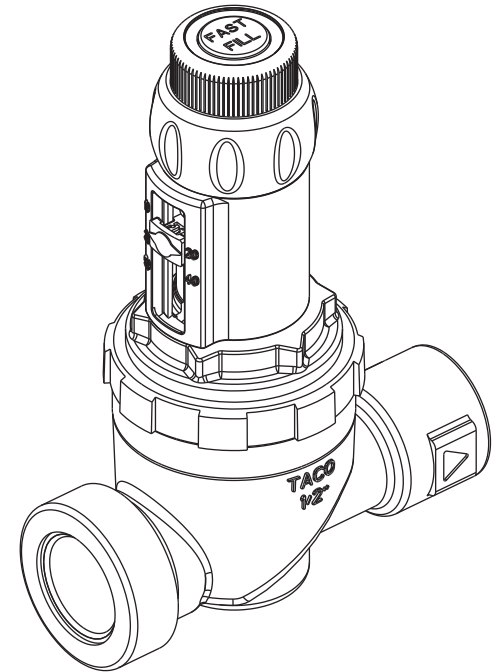

# Cartridge Pressure Reducing Valve (PRV)

### COMFORT MADE EASY®

TACO, INC., 1160 Cranston Street, Cranston, RI 02920 Telephone: (401) 942-8000 FAX: (401) 942-2360.  
TACO (Canada), Ltd., 8450 Lawson Road, Unit #3, Milton, Ontario L9T 0J6. Telephone: 905/564-9422. FAX: 905/564-9436.  
Visit our web site at: <http://www.taco-hvac.com> Printed in Germany Copyright 2010 TACO, Inc.

### Application:

Taco's PRV (Boiler Feed Valve) is designed for use in today's Hydronic heating systems. The model 3350 PRV reduces incoming pressure and automatically maintains the system pressure to the valve's adjustable set point. If the system pressure drops below the valve's set point it will automatically add water to the system. It is suitable for systems with fill pressure requirements between 10-50 PSI. The Taco PRV showcases a fast fill button with automatic reset. The valve automatically exits the fast fill mode once the system is full and the desired set pressure is reached. No more manually holding the valve open or locking it in an open position, possibly over pressurizing to the point of setting off the relief valve.

### Installation:

1. Install the valve in the direction indicated by the flow arrows on the body. The valve can be installed in any orientation. Rotate the set point indicator so that the pressure setting is always visible (figure 1).

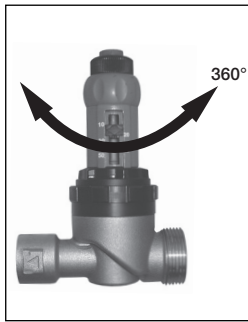

Figure 1

2. The 3350 PRV connects via a 1/2" NPTF on the outlet and may be connected using either the 1/2" NPTF or the Taco union threads on the inlet. The Taco union threads are more commonly used on existing installations already connected by a union nut. To use the union connection, remove the plastic thread protector on the valve inlet and connect the existing union nut. Replace the old union gasket with the new one supplied with the 3350.

**Note:** This product should be installed by professionals familiar with the correct function and performance of hydronic heating systems and their associated components.

**Caution:** Protect the 3350 from freezing and exposure to chemicals or solvents.

### Adjusting the Set Pressure:

1. Turn the green locknut counter clockwise to loosen (figure 2).
2. Turn the adjustment knob (figure 3) counter clockwise to reduce pressure or clockwise to increase the pressure until the indicator points to the desired pressure setting.
3. The PRV does not release pressure. When adjusting to a lower setting any excess pressure will need to be released through a suitable release point. Turn the green locknut clockwise until finger tight.



Figure 2

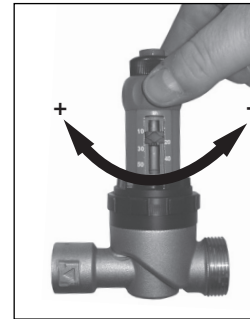

Figure 3

### Fast Fill:

The 3350 is equipped with an automatically resetting fast fill feature. The fast fill overrides the set pressure during filling and purging of the system. To activate the fast fill simply push in the button marked fast fill located on top of the PRV (figure 4). When the set pressure is reached the fast fill button will pop out. The valve is now out of the fast fill mode and back into the normal operating mode.

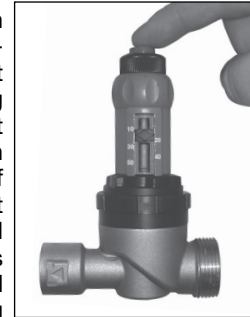

Figure 4

**NOTE:** If the fast fill button is unintentionally pushed in prior to installation it may be returned to the normal operating mode as follows.

1. Unscrew and remove the lock knob carefully so as not to lose the spring.
2. If the spring is still inside the lock knob remove it.
3. Using a suitable tool, such as a small screwdriver or pen, reach inside the lock knob and push the button back out.
4. Put the spring back into the lock knob and screw the knob back onto the cartridge.

### Maintenance:

To clean the integrated strainer in the pressure reducing valve, close the isolating valve upstream of the unit. Remove the PRV cartridge by turning the black 8 point cam nut on the cartridge counter clockwise and pull out. Clean with water only. Reverse the procedure to install (figure 5).

**Caution:** Do not over tighten the cartridge as this may damage the threads in the new cartridge or in the valve body and require that they be replaced.

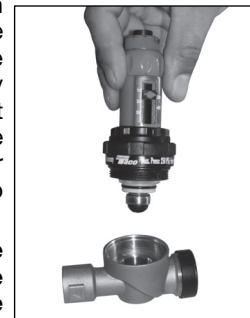
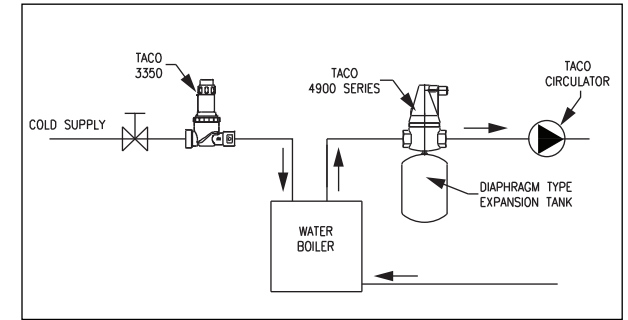

Figure 5

### Installation Diagram:



### Dimensions:

