

250 PSI CWP Iron Body Gate Valve

Bolted bonnet • non-rising stem • resilient wedge

250 PSI/17.2 bar non-shock cold working pressure

CONFORMS TO AWWA C509

EPOXY MEETS OR EXCEEDS AWWA C550

END CONNECTIONS DESIGNED FOR USE WITH C900 PVC PIPE
CERTIFIED LEAD-FREE* BY IAPMO R&T TO NSF/ANSI 372



PCR-619-RW
Ductile IPS Push-On

MATERIAL LIST

PART	SPECIFICATION
1. Valve Body	Ductile Iron ASTM A536
2. Resilient Wedge	Ductile Iron Disc Encapsulated by EPDM ASTM D 2000
3. Wedge Nut	Bronze ASTM B584 Alloy C83600
4. Stem	Aluminum Bronze ASTM B 150 Alloy C61400
5. Bonnet Gasket	EPDM ASTM D 2000
6. Bonnet Screw	18-8 Stainless Steel ASTM A193
7. Bonnet	Ductile Iron ASTM A536
8. Stem Primary O-Ring	EPDM ASTM D 2000
9. Stem Thrust Washer (lower)	Bronze ASTM B584
10. Stem Thrust Washer (upper)	Stainless Steel ASTM A 276 UNS S 41000
11. Gland Seal O-Ring	EPDM ASTM D 2000
12. Stem Seal Bushing	Bronze ASTM B584
13. Stem Secondary O-Ring (2)	EPDM ASTM D 2000
14. Gland Flange	Ductile Iron ASTM A536
15. Wiper Ring - Stem	EPDM ASTM D 2000
16. Nut, Wrench - Square	Iron ASTM A126-B
17. Washer, Wrench Nut	Carbon Steel, DIN 9021 B
18. Screw WR Nut	Alloy Steel ASTM A 574 M Zinc Plated
19. Screw, Gland Flange	Alloy Steel ASTM A 574 M Zinc Plated
20. Handwheel (Optional)	Ductile ASTM A536 (not pictured)

Coating — Electrostatically applied fusion-bonded epoxy 8-20 mil. inside and outside.
Meets or exceeds performance requirements of AWWA C550.
Epoxy coating is not intended to serve as a dielectric barrier internal to the piping system.

Maximum operating temperature 160°F/71°C.

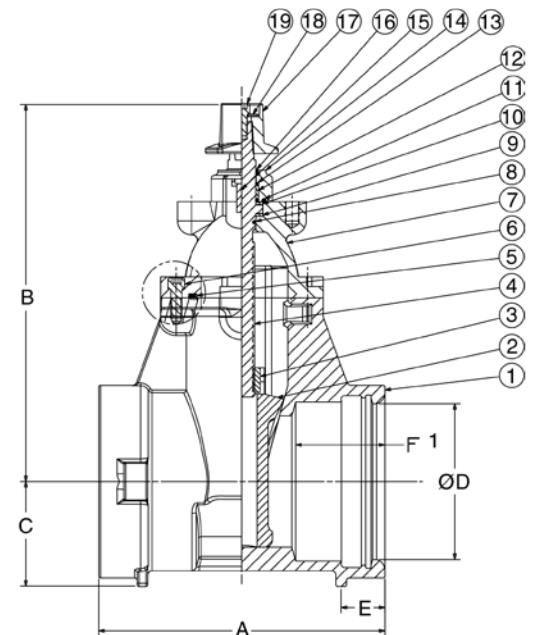

DIMENSIONS — WEIGHTS — QUANTITIES

Size	A		B		C		D		E		F		Hand Wheel (Optional)		Turns to Open	Weight	
	In.	mm.	In.	mm.	In.	mm.	In.	mm.	In.	mm.	In.	mm.	In.	mm.		Lbs.	Kg.
4	100	272	13.5	342	3.5	90	4.9	125	1.8	46	3.5	89	10.2	260	13.0	62	28
6	150	327	17.0	432	4.7	120	7.0	178	2.0	50	4.0	102	14.8	375	15.6	106	48
8	200	396	20.4	519	5.9	150	9.2	233	2.5	64	4.5	114	14.8	375	17.3	187	85
10	250	432	23.8	605	8.0	203	11.2	285	2.4	60	5.2	132	15.7	400	21.4	286	130
12	300	457	27.0	686	9.5	242	13.3	338	2.5	64	5.5	140	19.7	500	25.3	418	190

*Weighted average lead content ≤ 0.25%

VISIT WWW.NIBCO.COM FOR CURRENT CHEM-GUIDE AND GALVANIC POTENTIAL IN PIPING SYSTEMS INFORMATION.

Visit our website for the most current information.

FREEZING WEATHER PRECAUTION: Subsequent to testing a piping system, valves should be left in an open position to allow complete drainage.