

# SUBMITTAL INFORMATION

Ball Valve Curb Stop Minneapolis Pattern with Stop and Waste - (B11-xxxSWM-NL style)

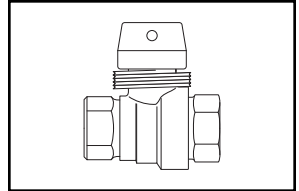

## FEMALE IRON PIPE THREAD INLET AND OUTLET

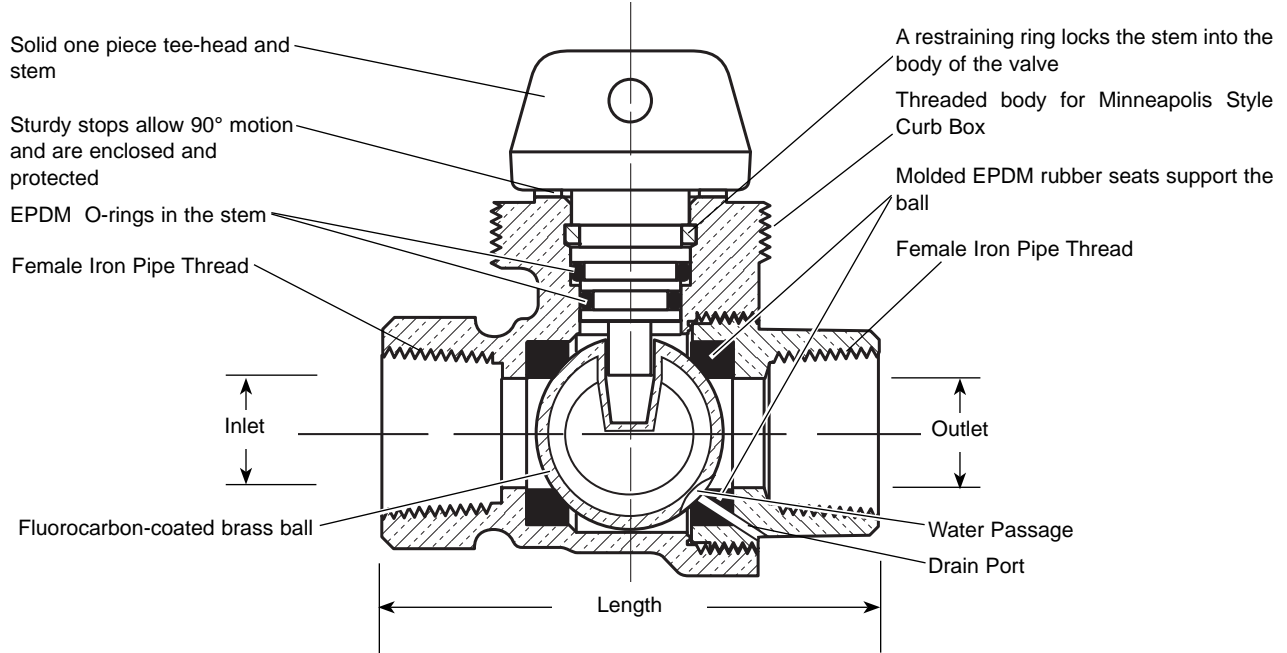

VALVE SIZE	INLET SIZE	OUTLET SIZE	LENGTH	APPROX. WT. LBS	PART NUMBER	✓ SUBMITTED ITEM(S)
1-1/2"	1-1/2"	1-1/2"	4-3/4"	7.1	B11-666SWM-NL	
2"	2"	2"	5-3/8"	8.4	B11-777SWM-NL	

### FEATURES

- All brass that comes in contact with potable water conforms to AWWA Standard C800 (ASTM B584, UNS C89833)
- The product has the letters "NL" cast into the main body for lead-free identification
- Brass components that do not come in contact with potable water conform to AWWA Standard C800 (ASTM B62 and ASTM B584, UNS C83600, 85-5-5-5)
- Ends are integral or secured with adhesive to prevent unintentional disassembly
- Hole for attaching curb box rod or handle is provided in tee-head
- 150 PSI working pressure

The Ford Meter Box Company considers the information in this submittal form to be correct at the time of publication. Item and option availability, including specifications, are subject to change without notice. Please verify that your product information is current.



**The Ford Meter Box Company, Inc.**

P.O. Box 443, Wabash, Indiana U.S.A. 46992-0443

Phone: 260-563-3171 / Fax: 800-826-3487

Overseas Fax: 260-563-0167

www.fordmeterbox.com

04/23/14

Submitted By: