

MODEL PRE & PRELF 1/2" - 2" (36E & 36ELF SERIES) PRESSURE REDUCING VALVE WITH INTEGRAL BY-PASS FEATURE

Installation

IMPORTANT! Prior to installing the Pressure Reducing Valve (PRV), all debris must be flushed from the line. Isolate the section where the PRV is to be installed by closing the shut-off valves. Refer to Table 1 for length dimensions for the size and end configuration of the PRV you plan to install. The PRV is designed to be installed in a piping system with the arrow on the valve pointing in the direction of flow.

Size	Dimensions					
	1/2"	3/4"	1"	1-1/4"	1-1/2"	2"
A	3.7"	3.7"	3.7"	5.5"	5.5"	5.5"
B	4.5"	4.7"	4.8"	6.7"	6.8"	7.0"
C	5.5"	5.7"	6.0"	7.8"	8.2"	8.4"



1915600

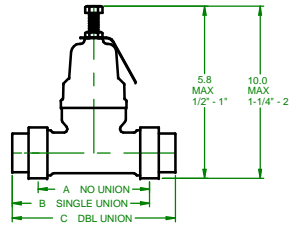

When the pressure reduction is greater than a ratio of 4:1 (Ex: 200 psi to 50 psi), multiple PRV's installed in series is required.

NOTE: If a solder union is to be used, sweat the union tailpiece and nut onto the pipe prior to installing the PRV assembly, otherwise the heat could damage the assembly components.

Operation

The PRV is designed to reduce pressure to a more functional level within its adjustment range. A gauge must be used to verify setting. To increase the set pressure, loosen the locknut and turn the adjusting screw clockwise. To decrease the set pressure, turn the adjusting screw counter-clockwise. Open a fixture to purge excess pressure, then verify setting. Re-tighten the locknut. Allow for some fall-off from set pressure during flow conditions. Refer to Chart 1 below to determine the amount of fall-off to expect at a certain rate of flow.

Example: A 3/4" PRV has an inlet pressure of 100 psi and a set outlet pressure of 50 psi in the static, no-flow condition. The flow demand through the valve is expected to be 25 gpm. The chart shows the pressure fall-off to be about 13 psi. Thus the pressure will drop from 50 psi to approximately 37 psi at that flow rate.

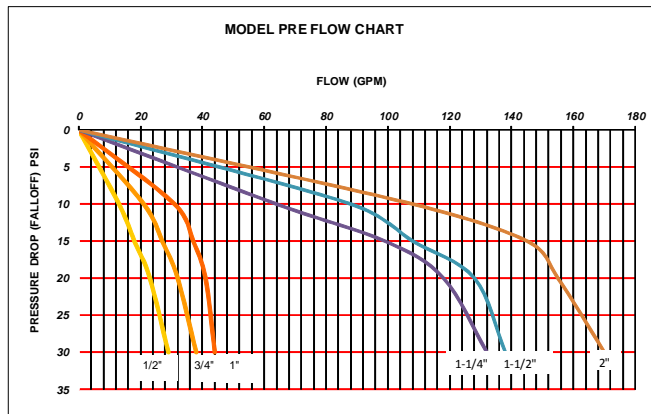

NOTE: Although this chart shows curves at a 50 psi set differential, curves for other settings are similar. The curve shifts slightly to the left for a smaller differential and to the right for a greater differential. The adjustment is as follows: for a 25 psi set differential subtract 15% from the flow rate shown. For a 75 psi set differential add 15% to the flow rate shown.

U.S. SAFE DRINKING WATER ACT WARNING: FOR NON-LEAD FREE VALVES:

It is illegal to use this product in the United States for potable water services (water intended for human consumption).

FIGURE 1

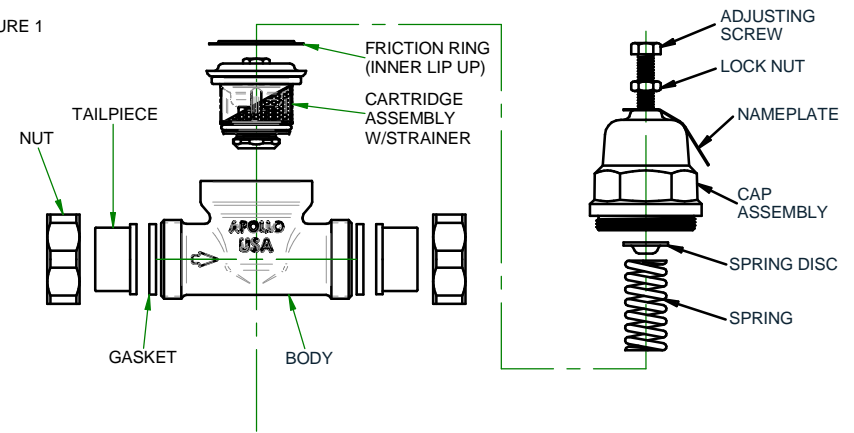

Maintenance

The 36E & 36ELF Series PRV can be serviced by removing the cap assembly. Routine servicing usually requires that the strainer be inspected to remove captured debris. Over time a clogged strainer can severely limit flow resulting in a high pressure loss across the device. Less frequently the rubber seat disc may need to be replaced as it sometimes becomes embedded with grit and other foreign particles. Both the strainer and seat assembly can be accessed by removing the cap. See figure 1. Replacement cartridge assemblies which include the strainer and seat assembly are available.

CAUTION: ALWAYS ISOLATE THE PRV PRIOR TO SERVICING!

Always relieve the spring pressure by unscrewing the adjusting screw before attempting to unscrew the cap assembly. Measure the height of the adjusting screw prior to loosening to return the valve to its original pressure setting.

Unscrew the cap assembly by placing a wrench on the 1-3/4" hex and turn counter-clockwise. The cartridge assembly can be carefully pulled out of the body using pliers on the hex bolt. Clean the strainer and inspect the cartridge assembly for any damage. Inspect the valve body for any debris. Apply a non-toxic or NSF approved lubricant on the cartridge o-ring prior to installation. Install the cap and tighten. Reset the adjusting screw to the previously measured height and tighten the lock nut. ALWAYS use a gauge to check the pressure in the downstream line. Flow a small amount of water and recheck the setting.

Trouble-Shooting

PROBLEM	POSSIBLE CAUSES
1. Gauge indicates outlet set pressure rises above the original setting.	A. If the rise is slow and not immediately noticed, the problem could be thermal expansion in the downstream line. If this is the problem, the pressure should drop immediately after flow resumes. If the pressure is not relieved and rises to equal the inlet pressure to the PRV, the by-pass feature then will prevent any further increase by by-passing the pressure upstream. B. A PRV that quickly rises above its set outlet pressure indicates some sort of seal leakage within the valve. Remove the clean-out plug and inspect the plug O-rings and the seat disc for cuts or particles. Clean or replace as necessary.
2. Lack of flow.	A. Lack of pressure at the supply. Fluctuations at the source may be temporary and correct itself. B. Several fixtures in the downstream line may be open creating a high demand. It may be necessary to adjust the PRV to a higher setting if a higher flow demand is required. C. Clogged strainer in the PRV. Remove clean-out plug and rinse strainer.
3. Excessive noise within the pipeline at the PRV.	High water velocities can sometimes cause a whistling or hum. A slight adjustment of the PRV may eliminate the noise. If not, the line size may be too small for the flow rate. See Chart 1 for capacities of the different PRV sizes.
4. Leakage from cap.	Loose cap, damaged diaphragm, or loose center bolt on cartridge assembly. If tightening the cap will not correct the leakage, then inspect the cartridge assembly. Check to see if the center bolt is tight. If the diaphragm is damaged, replace the cartridge assembly.

For more information visit www.apollovalves.com

CONBRACO INDUSTRIES, INC., 1418 S. Pearl St., Pageland, S.C. 29728 Phone: (704)841-6000