

# Liberty Pumps®

## Installation Manual

2399000A

## ProVore™ Residential Grinder Pumps

### Models:

PRG101A	1 hp, 115V, 1 phase, Automatic Switch, 10' Power cord
PRG101A-2	1 hp, 115V, 1 phase, Automatic Switch, 25' Power cord
PRG101M	1 hp, 115V, 1 phase, 10' Power cord
PRG101M-2	1 hp, 115V, 1 phase, 25' Power cord
PRG102A	1 hp, 230V, 1 phase, Automatic Switch, 10' Power cord
PRG102A-2	1 hp, 230V, 1 phase, Automatic Switch, 25' Power cord
PRG102M	1 hp, 230V, 1 phase, 10' Power cord
PRG102M-2	1 hp, 230V, 1 phase, 25' Power cord

**\*Do not throw away or lose this manual.**

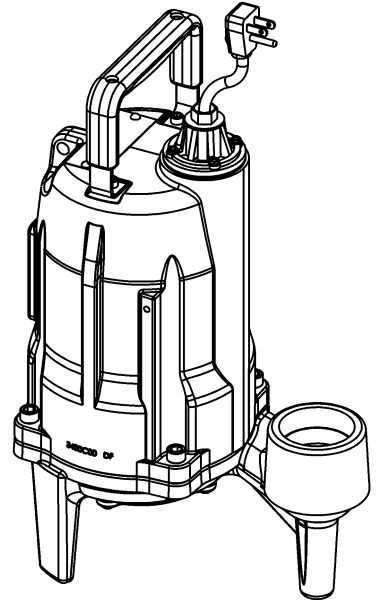

## Contents

- General Information
- Introduction
- Mechanical Installation
- Electrical Connection
- Operation
- Troubleshooting
- Warranty

### IMPORTANT:

Prior to installation, record Model, Serial Number, and Code Number from pump nameplate for future reference.

MODEL \_\_\_\_\_

SERIAL \_\_\_\_\_

CODE \_\_\_\_\_

INSTALLATION  
DATE \_\_\_\_\_

# Liberty Pumps®

7000 Apple Tree Avenue  
Bergen, NY 14416  
Phone: (800) 543-2550  
Fax: (585) 494-1839  
www.libertypumps.com



# 1. General Information

Before installation, read the following instructions carefully. Each Liberty pump is individually factory tested to insure proper performance. Closely following these instructions will eliminate potential operating problems, assuring years of trouble-free service.

## WARNING

- **Risk of electric shock.** Always disconnect the pump from the power source before handling or making adjustments.
- The electrical connections and wiring for a pump installation should only be made by qualified personnel.
- This pump is supplied with a grounding conductor and grounding-type attachment plug. To reduce the risk of electric shock, be certain that it is connected only to a properly grounded, grounding-type receptacle.
- DO NOT bypass grounding wires or remove ground prong from attachment plugs.
- DO NOT use an extension cord.
- This pump requires a separate, properly fused and grounded branch circuit. Make sure the power source is properly sized for the voltage and amperage requirements of the pump, as noted on the nameplate.
- The electrical outlet shall be within the length limitations of the pump power cord, and at least 4 feet above floor level to minimize possible hazards from flood conditions.
- The installation must be in accordance with the National Electric Code, Uniform Plumbing Code, International Plumbing Code, as well as all applicable local codes and ordinances.
- Sump and sewage pumps often handle materials which could cause illness or disease. Wear adequate protective clothing when working on a used pump or piping.
- Never enter a pump basin after it has been used. Sewage and effluent can emit several gases which are poisonous.
- Keep clear of suction and discharge openings. To prevent injury, never insert fingers into pump while it is plugged in.
- DO NOT use this product for flammable or corrosive liquid.
- DO NOT use this product in applications where human contact with the pumped fluid is common (such as swimming pools, fountains, etc.)
- NEVER dispose of materials such as paint thinner or other chemicals down drains, as they can chemically attack and damage pump components, potentially causing product malfunction or failure.
- DO NOT run pump dry, this product is intended to be partway submerged when operating.

## CAUTION

- Do not use these pumps in water over 140° F.
- The Uniform Plumbing Code (UPC) states that sewage systems shall have an audio and visual alarm that signals a malfunction of the system, to reduce the potential for property damage.
- A 20 amp breaker is recommended for 115V pumps.

Model	HP	Volts	Phase	Full Load Amps	FNPT Discharge	Automatic or Manual*
PRG101A	1	115	1	12	2"	Automatic
PRG101A-2	1	115	1	12	2"	Automatic
PRG101M	1	115	1	12	2"	Manual
PRG101M-2	1	115	1	12	2"	Manual
PRG102A	1	230	1	6	2"	Automatic
PRG102A-2	1	230	1	6	2"	Automatic
PRG102M	1	230	1	6	2"	Manual
PRG102M-2	1	230	1	6	2"	Manual

\* **Note:** Manual models ("M" suffix), require a separate approved pump control device or panel for automatic operation. Operation of these models will be according to the control selected. Make sure the electrical specifications of the control selected properly match the electrical specifications of the pump. Always refer to control panel instructions for proper installation.

## 2. Introduction

### INTRODUCTION

This manual was prepared to assist you in the correct installation, operation, and maintenance of your Liberty pump. Please read it completely before installing the pump. Make certain that you are familiar with the contents, and the chapters on installation and operation are fully understood before running the pump.

Liberty Pumps are designed for minimal maintenance. However, regular checks will ensure longer life and greater operating reliability.

**WARRANTY:** No repair work should be carried out during the warranty period without prior factory approval. To do so may render the warranty void.

**SERIAL #:** In all correspondence and reports, make certain that the pump serial number is given.

### DESIGN OF PUMP

**⚠ WARNING** The grinder pump contains metal parts that rotate at high speeds. Be careful around pump base while power is connected. Make sure that the pump is either in the tank or clear from people and wires when in operation.

1. Liberty Provo<sup>TM</sup> Series grinder pumps are designed for continuous underwater operation. The motor and pump form a close coupled, watertight unit. The induction motor is insulated against heat and moisture, Class B insulation.
2. A thermal overload protector is imbedded in the stator windings. This is connected in series and wired to shut down the pump if overheating occurs. The overload switch resets automatically when the motor cools.
3. The motor is protected against damage from water entry by a mechanical type cartridge seal with two silicon-carbide faces.
4. The impeller and volute are designed for efficient flow characteristics and clog-free operation. The hardened cutters grind solids and fibrous matter into small particles that can be safely pumped through small diameter piping.
5. For sewage systems, consult local plumbing codes on requirements for venting the tank. The pump shall not be installed in locations classified as hazardous in accordance with the National Electrical Code, ANSI/NFPA70.

**NOTE:** The primary material of the Liberty PRG Series Pumps is cast iron, elastomers are Buna-N. They should not be used to pump corrosive liquids.

## 3. Mechanical Installation

### INSPECTION UPON RECEIPT

The shipping container should be immediately inspected for damage that may have occurred in shipment. Exercise care in opening the shipping container to avoid damage to the pump. Remove any blocking and cushioning from within the container.

Check all cushioning for spare parts before discarding. Visually check the pump and any spare parts for damage. Check for damaged electrical wires, especially where they exit the motor housing. Contact the Liberty Pumps Customer Service Department to report any damage or shortage of parts. The cutter located on the bottom of the unit should be turned several rotations with the use of a 6 mm hex wrench, it should rotate freely without rubbing on the cutter plate. This will insure that the impeller and cutter are free of any seizure due to prolonged storage. If the impeller is not rotated manually prior to installation, the pump may fail to activate. If the impeller's rotation is difficult or completely resistant, contact the Liberty Pumps Customer Service Department.

## STORAGE BEFORE USE

Liberty pumps are shipped from the factory ready for installation and use. They should be held in storage if the pump station is not complete. If storage is necessary, the pump should remain in its shipping container. It should be stored in a warehouse or storage shed that has a clean, dry temperature-stable area where the pump and its container should be covered to protect it from water, dirt, dust, etc. The ends of the cables - (plugs) must be protected against moisture.

### CAUTION

**AT NO TIME SHOULD THE PUMP BE STORED WITHIN AN INCOMPLETE WET PIT. THE PUMP SHOULD NOT BE PLACED INTO THE PIT UNTIL IT CAN BE FULLY OPERATED.**

## LONG TERM STORAGE

1. If it is necessary to store a pump for a long period of time, it should be stored indoors in a clean, dry temperature-stable environment. The pump should be covered to protect it from dust, dirt and water. The plug end of the cable must be protected against moisture.
2. Do not allow the pump to freeze.
3. Prior to installation, the pump motor should be rotated to ensure the seals and cutters are free spinning.
4. Installed pumps which are idle for long periods of time should be manually operated through the breaker panel once a month to lubricate the seals. Turn off the breaker, unplug the piggyback switch, and plug the pump directly into the wall socket. Turn the breaker on for 30 seconds. Turn the breaker off, and then plug the piggyback switch back in.

## 4. The Basin

The basin required for both effluent and sewage applications must be sealed and vented to meet health and plumbing code requirements. These pumps are not to be installed in locations classified as hazardous in accordance with the National Electric Code, ANSI/NFPA 70. The diameter should be a minimum of 18" and the depth a minimum of 24". (These are minimum requirements. A larger basin may be required in both effluent and sewage applications depending on local codes and the number of fixture units entering the system. Check with the local authorities or contact Liberty Pumps if you are unsure of the proper basin size.) Installation should be at a sufficient depth to ensure that all plumbing is below the frost line. If this is not feasible, remove the check valve and size the basin and/or adjust pump differential to accommodate the additional backflow volume.

- A. **Excavation:** Excavate the hole as small as possible, with a minimum recommended 8" diametrical clearance around the tank. Never place the basin directly in contact with rocks or other sharp objects. Place only fine, 1/8" to 3/4" pea gravel or 1/8" to 1/2" washed, crushed stone as bedding between the basin and the hole walls. Do not use sand or native soil as backfill. Properly compact underneath the basin to provide a solid, level base that can support the weight of the filled basin.
- B. **Inlet Connection & Initial Backfill:** Only fine, 1/8" to 3/4" pea gravel or 1/8" to 1/2" washed, crushed stone should be used around the bottom of the basin to hold it in place. Do not use sand or native soil as backfill. Make the inlet connection as required for your basin.

**Liberty P380, & P680:** The Liberty Pro Series basins have a 4" inlet molded to the side of the tank. This inlet is sized to accept a 4" no-hub type coupling. Connect the gravity drainage line from the fixtures to this hub.

**Other Basins:** Other Liberty basins provide a 4" caulking hub or pipe grommet inlet. Hubs utilize caulking material or rubber donuts; grommets are a simple slip-fit. Connect the gravity drainage line from the fixtures to this opening. (Other inlet sizes available – consult factory.)

- C. **Final Backfill:** Large rocks, clods, and foreign objects should be kept out of the backfill material. Only fine, 1/4" to 3/4" pea gravel, or 1/8" to 1/2" washed, crushed stone is recommended. Do not use sand or native soil as backfill. Mound the backfill slightly and allow for natural settling. Provide access to the basin cover for maintenance and service.

### CAUTION

**Do not exert heavy pressure or run heavy equipment on the backfill material as this could cause the tank to collapse.**

## 5. Installation of the Pump

**⚠ WARNING** THIS PUMP IS NOT TO BE INSTALLED IN LOCATIONS CLASSIFIED AS HAZARDOUS IN ACCORDANCE WITH THE NATIONAL ELECTRICAL CODE, ANSI/NFPA 70.

Grinder pumps must be installed in a tank that is vented in accordance with local plumbing codes. Installation should be at a sufficient depth to ensure that all plumbing is below the frost line. If this is not feasible, remove the check valve and size the basin and/or adjust pump differential to accommodate the additional backflow volume. Consult the factory for details on how this should be done.

ALARM (OPTIONAL)

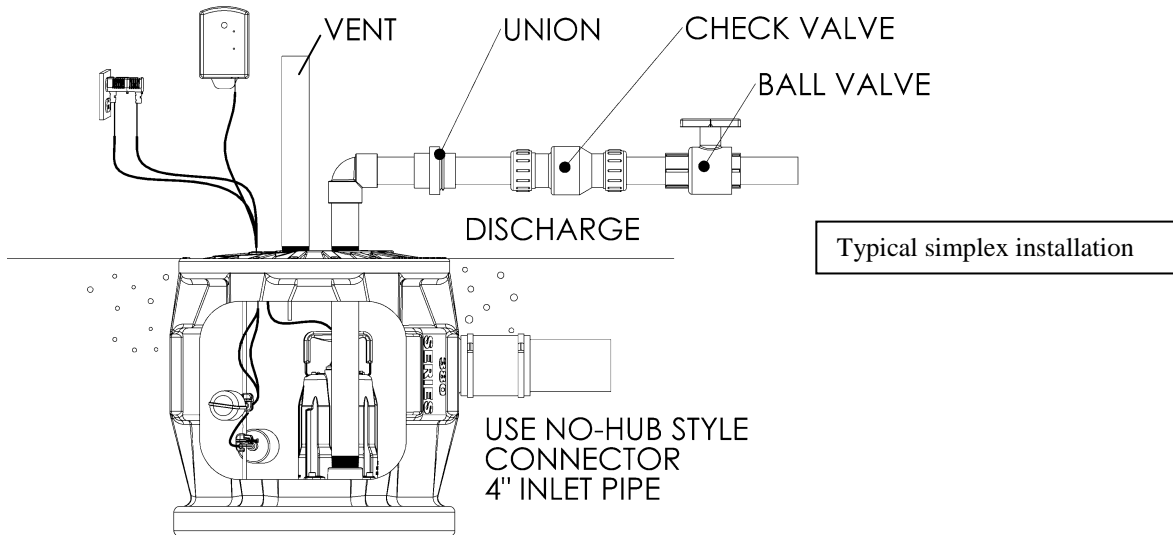

## 6. Electrical Service & Operation

**⚠ WARNING**

- **Risk of electric shock.** Always disconnect the pump from the power source before handling or making adjustments.
- The electrical connections and wiring for a pump installation should only be made by qualified personnel.
- This pump is supplied with a grounding conductor or a grounding type attachment plug. To reduce the risk of electric shock, be certain that the grounding conductor is connected only to a properly grounded control panel or, if equipped with a grounding type plug that it is connected to a properly grounded, grounding type receptacle.
- DO NOT bypass grounding wires or remove ground prongs from attachment plugs.
- DO NOT remove cord and strain relief and DO NOT connect conduit to pump.
- DO NOT use an extension cord.
- This pump requires separate, properly fused and grounded branch circuit. Make sure the power source is properly sized for the voltage and amperage requirements of the motor, as noted on the pump nameplate.
- The electrical outlet or panel shall be within the length limitations of the pump power cord, and at least 4 feet above floor level to minimize possible hazards from flood conditions.
- The installation must be in accordance with the National Electric Code and all applicable local codes and ordinances.

**⚠ CAUTION**

When the risk of property damage from high water levels exists, an independent high water alarm should be installed. A duplex pumping system is recommended for critical installations.

**Fig. 4 Piggyback plug installation.**

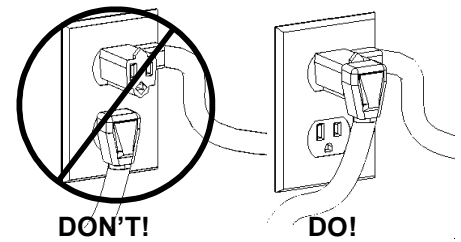

All "A" models (automatic pumps) come factory-equipped with a float switch mounted to the pump. These models come with two cords - one to the float switch and the other to the pump motor. The switch cord has a series (piggyback) plug enabling the pump (motor) cord to be plugged into the back of it (see Fig. 4). The purpose of this design is to allow manual operation of the pump. Note, on / off operation of the pump must be controlled by the circuit breaker.

**For automatic operation** using Liberty's supplied switch, the two cords should be interconnected and plugged into a separately fused, grounded outlet of proper amp capacity for your selected pump model. (See Section 1, General Information, or the pump nameplate for electrical specifications of your model.) Both cords are equipped with 3-prong plugs and must be plugged into a properly grounded 3-wire receptacle. **DO NOT REMOVE THE GROUND PRONGS.**

In the event of switch failure, the pump cord can be separated and plugged into the electrical outlet, directly bypassing the switch. For 115V and 230V single phase pumps should only be operated without the float switch by using the circuit breaker or panel disconnect. Do not let the pump run dry.

The turn-on level of automatic "A" models is approximately 12" to 16" above the bottom of the basin. The turn-off level is approximately 6" above the bottom of the basin. Other pumping differentials may be obtained by tethering the switch cord to the discharge pipe. **NOTE:** A minimum cord length of 3.5" from the tether point to the top surface of the float is required for proper switch operation. If using a differential other than the factory setting, be sure when the pump shuts off at least 6" of fluid is left in the basin so the impeller remains submerged.

**PRG Series pump models with an "M" designation** are manual models with no switch. They are intended to be run using an approved liquid level control or approved motor control with correct rating that matches motor input in full load amperes. 3-phase models require the use of an approved motor control that matches motor input in full load amperes with overload element(s) selected or adjusted in accordance with control instructions.

**Automatic operation with optional control devices:** If the pump(s) are to be operated by either a simplex or duplex control panel, or other optional control device, follow the installation instructions provided with your specific control and make the power connections per those instructions. If necessary, certain models may be run without a separate control. 230V single-phase pumps should only be operated without the float switch by using the circuit breaker or panel disconnect. Do not let the pump run dry.

**ProVore "A" and "M" models:** If the pump is to be wired directly into a control device or junction box, and it is necessary to remove the plugs, have a certified electrician do the wiring in accordance with the National Electric Code and applicable local codes. See Fig. 5 for direct wire installation of single phase, automatic pumps.

**⚠ WARNING**

In 230V installations, one side on the line going to the pump is always "hot", whether the float switch is on or off. To avoid hazards, install a double pole disconnect near the pump installation.

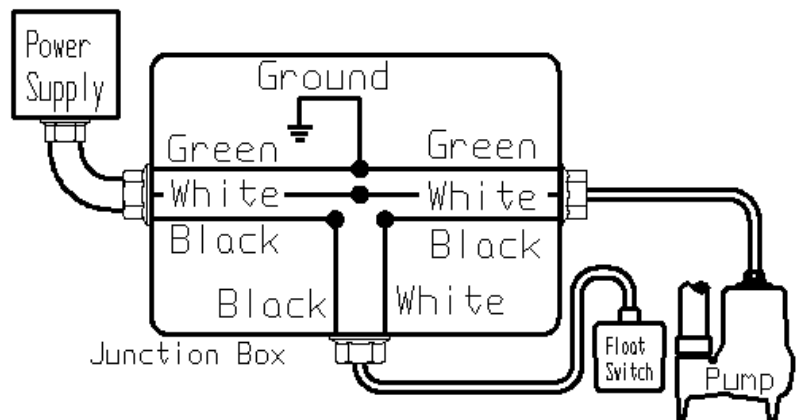

**Direct Wiring of 115V or 230V, Single Phase, Automatic Pumps**

## STEPS TO BE TAKEN BEFORE ENERGIZING

1. Retighten all field-made connections. Retighten all factory-made connections. These may have loosened due to shipping and handling vibrations.
2. Check the security of mounting hardware.
3. Check the enclosure to see that it has not been damaged in such a manner as to reduce electrical spacing.
4. Rotate the cutter wheel with the hex socket head cap screw to verify movement and lubricate the seals.
5. Ensure that no wires or other obstacles are in the way of the pump cutter.
6. MOTOR OVERLOAD PROTECTION: The pump motor is protected from locked rotor and running overloads by a thermal overload integrally mounted to the motor. No adjustments are required.
7. Check to determine that all grounding connections are made properly

If a panel is used, remove all debris, scrap wire, etc., from the control panel interior before closing the doors. Install covers, close doors making certain that no wires are pinched and that all enclosure parts are properly aligned and tightened.

**⚠ WARNING** **ENERGIZING THE CONTROL PANEL OR BREAKER FOR THE FIRST TIME IS POTENTIALLY DANGEROUS. LICENSED ELECTRICAL PERSONNEL SHOULD BE PRESENT WHEN THE PANEL OR BREAKER IS ENERGIZED FOR THE FIRST TIME. IF FAULTS CAUSED BY DAMAGE OR POOR INSTALLATION PRACTICES HAVE NOT BEEN DETECTED, SERIOUS DAMAGE CAN RESULT WHEN POWER IS APPLIED (REFER TO SECTION 5).**

### FLOAT SWITCHES

1. The pump's on and off cycles are normally controlled by a "piggy back" float switch attached to the side of the pump, or by hanging switches in the wet well. Refer to panel or switch instructions for proper electrical connection

### FLOAT SEQUENCE- PIGGY BACK SWITCH (AUTOMATIC MODELS)

1. As the liquid level in the wet well rises, the float tilts, closing the switch. This starts the pump.
2. The pump runs until the liquid level falls to the "PUMP OFF" level of the float (Factory set - 6" minimum).

### FLOAT SEQUENCE- SIMPLEX CONTROL PANEL (MANUAL MODELS)

1. As the liquid level in the wet well rises, the "PUMP OFF" float tilts, closing the switch (This level must be set at a minimum of 6"). As the liquid level continues to rise, the "PUMP ON" float tilts. This switch closes, starting the pump.
2. The pump runs until the liquid level falls below the "PUMP OFF" float, emptying the wet well.
3. In the event of a malfunctioning float switch, control relay or pump, the liquid level rises and tilts the "HIGH LEVEL ALARM" float. The alarm system will activate.

### FLOAT SEQUENCE-DUPLEX CONTROL PANEL (MANUAL MODELS)

1. As the liquid level in the wet well rises, the "PUMP OFF" tilts, closing the switch. As the liquid level continues to rise, the "LEAD PUMP ON" float tilts. This switch closes, starting the lead pump. The pump runs until the liquid level falls below the "PUMP OFF" float (6" minimum), emptying the wet well.
2. On the next rise of the liquid level, the other pump will start on the "LEAD PUMP ON" signal. The pumps will continue to alternate their cycles.

**NOTE: The ON/OFF float switch differential should be set as to not exceed 12 starts per hour.**

3. If the liquid level rises to the "LAG PUMP ON" float, the second pump will start. Both pumps will run until the liquid falls below the "PUMP OFF" float, emptying the wet well.
4. In the event of a malfunctioning float switch, control relay or pump, the liquid level rises and tilts the "HIGH LEVEL ALARM" float. The alarm system will activate.

## **FLOAT SWITCH INSTALLATION**

The engineering drawings will normally specify the levels for pump start and stop and high level alarm. If they are not specified, these guidelines should be used to determine float switch locations.

### **PIGGY BACK SWITCH**

(1-Float System)

Pump Off: Factory set. (Float tether 3.5")

Pump On: Factory set. (Float tether 3.5")

### **SIMPLEX PUMP STATION**

(3-Float System)

Pump Off: Level to top of motor housing.

Pump On: Minimum 1-1/2 ft. above Pump Off Level.

High Level Alarm: Minimum 1 ft. above pump ON level. Below influent pipe.

### **DUPLEX PUMP STATION**

(4-Float System)

Pump Off: Level to top of motor housing.

Lead Pump On: Minimum 1-1/2 ft. above Pump Off level.

Lag Pump On: Minimum 1 ft. above Lead Pump On level.

High Level Alarm: Minimum 1 ft. above Lag Pump On level. Below influent pipe.



## 7. **Operation**

### **OPERATION**

After the electrical and mechanical installations have been performed, the pump is ready for operation. No operational procedures are required except to apply rated power to the pump. There are no specific shutdown procedures beyond disconnecting the power supply.

#### **⚠ CAUTION**

**IF THE ROTATION OF A SINGLE PHASE PUMP IS INCORRECT, NOTIFY THE LIBERTY PRODUCT SERVICE DEPARTMENT IMMEDIATELY. DO NOT SWITCH THE POWER SUPPLY LEADS. DO NOT OPERATE THE PUMP.**

#### **⚠ WARNING**

**ALWAYS ENSURE THAT THE PUMP IS FREE OF WIRES OR OTHER OBSTRUCTIONS THAT MAY CAUSE HARM OR INJURY.**

### **PERIODIC MAINTENANCE & LUBRICATION**

Liberty pumps are designed for long lasting, efficient and reliable service with a minimum of preventive maintenance checks. These checks are few but will add years of satisfactory service to the life of the pump

### **LUBRICATION**

Pump is permanently lubricated and cooled by turbine oil. If replacement oil is required, use ISO-32 turbine oil. If this is unavailable a full synthetic SAE 5W-30 or 5W-20 motor oil may be used. Capacity .5 gallons.

## 8. Maintenance and Troubleshooting



### WARNING

**Risk of electric shock.** Always disconnect the pump from the power source before handling or making adjustments.

This pump has an oil filled motor enclosure, drain oil before removing the four cover screws.

Problem	Cause	Correction
Pump will not run.	<ul style="list-style-type: none"> <li>Blown fuse or other interruption of power; improper voltage.</li> </ul>	<ul style="list-style-type: none"> <li>Check that the unit is securely plugged in. Have an electrician check all wiring for proper connections and adequate voltage and capacity.</li> </ul>
	<ul style="list-style-type: none"> <li>Switch is unable to move to the "turn on" position due to interference with the side of basin or other obstruction</li> </ul>	<ul style="list-style-type: none"> <li>Position the pump or switch so that it has adequate clearance for free operation.</li> </ul>
	<ul style="list-style-type: none"> <li>Insufficient liquid level.</li> </ul>	<ul style="list-style-type: none"> <li>Make sure the liquid level is allowed to rise enough to activate switch(s).</li> </ul>
	<ul style="list-style-type: none"> <li>Defective switch.</li> </ul>	<ul style="list-style-type: none"> <li>Remove and replace switch.</li> </ul>
Pump will not turn off.	<ul style="list-style-type: none"> <li>Switch(s) unable to move to the "turn off" position due to interference with the side of basin or other obstacle.</li> </ul>	<ul style="list-style-type: none"> <li>Position the pump or switch so that it has adequate clearance for free operation.</li> </ul>
	<ul style="list-style-type: none"> <li>Defective switch.</li> </ul>	<ul style="list-style-type: none"> <li>Remove and replace switch.</li> </ul>
Pump runs or hums, but does not pump.	<ul style="list-style-type: none"> <li>Discharge is blocked or restricted.</li> </ul>	<ul style="list-style-type: none"> <li>Check the discharge line for foreign material, including ice if the discharge line passes through or into cold areas.</li> </ul>
	<ul style="list-style-type: none"> <li>Check valve is stuck closed or installed backwards.</li> </ul>	<ul style="list-style-type: none"> <li>Remove check valve(s) and examine for freedom of operation and proper installation.</li> </ul>
	<ul style="list-style-type: none"> <li>Gate or ball valve is closed.</li> </ul>	<ul style="list-style-type: none"> <li>Open gate or ball valve.</li> </ul>
	<ul style="list-style-type: none"> <li>Total lift is beyond pump's capability.</li> </ul>	<ul style="list-style-type: none"> <li>Try to route piping to a lower level. If not possible, a larger pump may be required. <b>Consult the factory.</b></li> </ul>
	<ul style="list-style-type: none"> <li>Pump impeller is jammed or volute casing is plugged.</li> </ul>	<ul style="list-style-type: none"> <li>Remove the pump from the basin, remove cutter and cutter plate clean the area around the impeller. Reassemble and reinstall. The center screw uses a 6mm hex drive. The screw can be heated to remove thread locking compound</li> </ul>
Pump runs periodically when fixtures are not in use.	<ul style="list-style-type: none"> <li>Check valve was not installed, is stuck open or is leaking.</li> </ul>	<ul style="list-style-type: none"> <li>Remove check valve(s) and examine for freedom of operation and proper installation.</li> </ul>
	<ul style="list-style-type: none"> <li>Fixtures are leaking.</li> </ul>	<ul style="list-style-type: none"> <li>Repair fixtures as required to eliminate leakage.</li> </ul>
Pump operates noisily.	<ul style="list-style-type: none"> <li>Foreign objects in the impeller cavity.</li> </ul>	<ul style="list-style-type: none"> <li>Remove the pump from the basin, remove cutter and cutter plate clean the area around the impeller. Reassemble and reinstall. The center screw uses a 6mm hex drive. The screw can be heated to remove thread locking compound</li> </ul>
	<ul style="list-style-type: none"> <li>Broken impeller.</li> </ul>	<ul style="list-style-type: none"> <li>Consult the factory for information regarding replacement of impeller.</li> </ul>
	<ul style="list-style-type: none"> <li>Worn bearings.</li> </ul>	<ul style="list-style-type: none"> <li>Return pump to the factory or authorized repair station for repair.</li> </ul>
	<ul style="list-style-type: none"> <li>Piping attachments to building are too rigid.</li> </ul>	<ul style="list-style-type: none"> <li>Replace a portion of the discharge line with rubber hose or connector.</li> </ul>

## 9. **3 Year Limited Warranty**

Liberty Pumps, Inc. warrants that pumps of its manufacture are free from all factory defects in material and workmanship for a period of 3 years from the date of purchase. The date of purchase shall be determined by a dated sales receipt noting the model and serial number of the pump. The dated sales receipt must accompany the returned pump if the date of return is more than 3 years from the "CODE" (date of manufacture) number noted on the pump nameplate.

The manufacturer's obligation under this Warranty shall be limited to the repair or replacement of any parts found by the manufacturer to be defective, provided the part or assembly is returned freight prepaid to the manufacturer or its authorized service center, and provided that none of the following warranty-voiding characteristics are evident.

The manufacturer shall not be liable under this Warranty if the product has not been properly installed; if it has been disassembled, modified, abused or tampered with; if the electrical cord has been cut, damaged or spliced; if the pump discharge has been reduced in size; if the pump has been used in water temperatures above the advertised rating, or water containing sand, lime, cement, gravel or other abrasives; if the product has been used to pump chemicals or hydrocarbons; if a non-submersible motor has been subjected to excessive moisture; or if the label bearing the serial, model and code number has been removed. Liberty Pumps, Inc. shall not be liable for any loss, damage or expenses resulting from installation or use of its products, or for consequential damages, including costs of removal, reinstallation or transportation.

There is no other express warranty. All implied warranties, including those of merchantability and fitness for a particular purpose, are limited to three years from the date of purchase.

This Warranty contains the exclusive remedy of the purchaser, and, where permitted, liability for consequential or incidental damages under any and all warranties are excluded.



Bergen, NY 14416  
Phone: (800) 543-2550  
Fax: (585) 494-1839  
[www.libertypumps.com](http://www.libertypumps.com)