

SELF DRILLING SCREW

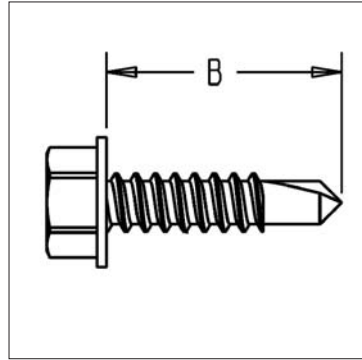

Product Data Sheet



Features

- Sharp Point - Won't run on light gauges
- Hardened Point - Will drill through up to 3/16" Thick Steel
- Highest Head In The Industry - To sit better in the magnetic chucks
- No pre-drilling necessary - cuts its own threads.

Description

Elgen's Self Drilling Screw is designed for fastening to aluminum and steel with a drill point tip.

Standard Construction

Manufactured from AISI 1016 or AISI 1024 Carbon Steel
Material and Mechanical Properties: SAE J933.
Dimensions: ASME B18.6.3 and ASME B18.6.4
Zinc-Clear Plating: Meet ASTM F1941 FeZn3C
Core Hardness: HRC 32-40

Unslotted hex washer head

Size	Across Flats (in)	Socket Size (in)	Washer Diameter
#8	1/4	7/16	0.322-0.348
#10	5/16	1/2	0.384-0.414
#12	5/16	1/2	0.398-0.432
#14	3/8	9/16	0.480-0.520

Optional Construction

- Stainless Steel 410
- Stainless Steel 304 (non-magnetic)
- Aluminum

Washer Bonded Neoprene gasket

Packaging

Size B	Qty Per Box	Size (B)	Qty Per Box
#8 x 1/2"	15,000	#10 x 3"	1,500
#8 x 3/4"	10,000	#12 x 3/4"	5,000
#8 x 1"	8,000	#12 x 1"	3,500
#8 x 1-1/2"	5,000	#12 x 1-1/2"	2,500
#8 x 2"	3,000	#12 x 2"	2,000
#10 x 1/2"	10,000	#12 x 3"	1,000
#10 x 3/4"	8,000	#12 x 4"	1,000
#10 x 3/4" Hi-Hat	5,000	#14 x 1"	3,000
#10 x 1"	5,000	#14 x 1-1/2"	2,000
#10 x 1-1/2"	3,000	#14 x 2"	1,000
#10 x 2"	2,000	#14 x 3"	1,000

Guarantee

All Elgen products are guaranteed by Elgen Manufacturing against defective material.

Elgen Manufacturing

10 Railroad Ave, Closter NJ 07624
Tel: 800.503.9805 :: Fax: 201.964.9030
info@elgenmfg.com :: www.elgenmfg.com