

2" Ultra Vane

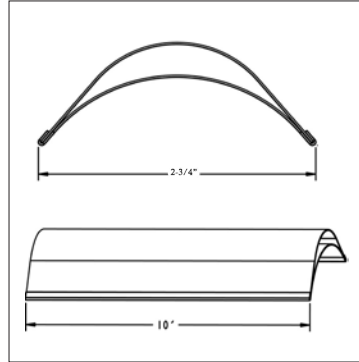

Product Data Sheet



Features

Patented- Made from one piece of metal
Meets SMACNA requirements
One Dimple per inch
Can be used with other rail systems
Union Made Yellow Label

Description

Elgen's 2" Ultra Vane (Double Wall Turning Vane) is used, in conjunction with Elgen's 2" Double Wall Vane Rail, for directing air flow through a rectangular elbow.

Optional Construction

22 or 24 GA ASTM A-653 G60/G90 Material
Stainless Steel 304
Stainless Steel 316
Aluminum
PCD
Galvanneal (Paint Grip)
Agion (Antimicrobial Coating)

Standard Construction

Rollformed using 26 GA ASTM A-653 G60
Material
10' length

Packaging

GA	Length (ft)	Bundle Qty (ft)	Skid Qty (ft)	Weight (lbs)
26	10	100	8500	3600

Guarantee

All Elgen products are guaranteed by Elgen Manufacturing against defective material.

Elgen Manufacturing
10 Railroad Ave, Closter NJ 07624
Tel: 800.503.9805 :: Fax: 201.964.9030
info@elgenmfg.com :: www.elgenmfg.com