

4" Turning Vane

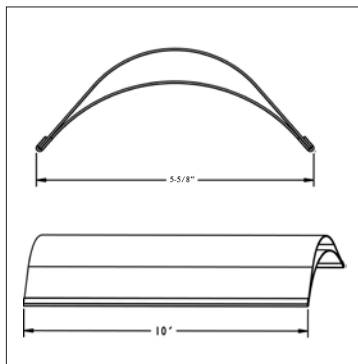

Product Data Sheet

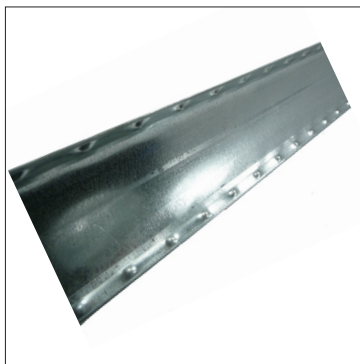

Features

- Meets SMACNA requirements
- One Dimple per inch
- Can be used with other rail systems
- Union Made Yellow Label

Description

Elgen's 4" Turning Vane (Double Wall) is used, in conjunction with Elgen's 4" Double Wall Vane Rail, for directing air flow through a rectangular elbow.

Optional Construction

- 20 or 22 GA ASTM A-653 G60/G90 Material
- Stainless Steel 304
- Stainless Steel 316
- Aluminum
- PCD
- Galvanneal (Paint Grip)
- Agion (Antimicrobial Coating)

Standard Construction

Rollformed using 24 GA ASTM A-653 G60
Material
10' length

Packaging

GA	Length (ft)	Bundle Qty (ft)	Skid Qty (ft)	Weight (lbs)
24	10	50	2100	2400

Guarantee

All Elgen products are guaranteed by Elgen Manufacturing against defective material.

Elgen Manufacturing
10 Railroad Ave, Closter NJ 07624
Tel: 800.503.9805 :: Fax: 201.964.9030
info@elgenmfg.com :: www.elgenmfg.com