

# Thermostatic mixing valves, low-lead, high-flow

## 5231 series



01256/14 NA



### Function

The thermostatic mixing valve is used in systems producing domestic hot water or in radiant heating systems. Its function is to maintain the temperature of the mixed water supplied to the user at a constant set value when there are variations in the supply pressure and temperature of the incoming hot and cold water or in the flow rate.

The 5231 series thermostatic mixing valves are ASSE 1017 approved for point of distribution and are designed specifically for systems requiring high flow rates and precise, stable temperature control.



### Product Range

- Code 5231\_0A Thermostatic mixing valve (ASSE 1017) with threaded connections.....sizes 1", 1-1/4", 1-1/2", 2" union NPT male
- Code 5231\_8A Thermostatic mixing valve (ASSE 1017) with sweat connections..... sizes 1", 1-1/4", 1-1/2", 2" union sweat
- Code 523177A Thermostatic mixing valve (ASSE 1017) with sweat connections and outlet temperature gauge..... sizes 1-1/4" union sweat

### Technical specification

- Materials:
- Body: Low-lead brass
  - Shutter: PPSG40
  - Springs: Stainless steel
  - Seals: EPDM
- Suitable fluids: Water, glycol solutions
- Maximum percentage of glycol: 30% glycol solution
- Setting range: See table on page 3
- Temperature stability: ± 3°F (± 2°C)
- Max working pressure (static): 200 psi (14 bar)
- Max operating differential pressure: 70 psi (5 bar)
- Hot water inlet temperature range: 120 – 195°F (49 – 91°C)
- Cold water inlet temperature range: 39 – 80°F (3.9 – 26.6°C)
- Mixed temperature range: 95 – 150°F (35 – 66°C)
- Maximum inlet pressure ratio (H/C or C/H): 2:1
- Minimum temperature difference between hot water inlet and mixed water outlet for optimum performance: 20°F (11°C)
- Maximum water hardness: 10 grains

Certifications:

1. cUPC Listed to ASSE 1017/CSA B125.3. Reduction of Lead in Drinking Water Act Compliant: 0.25% Max. weighted average lead content. Reduction of Lead in Drinking Water Act Certified by IAPMO R&T.
2. Meets requirements of ANSI/NSF 372-2011.

### Dimensions

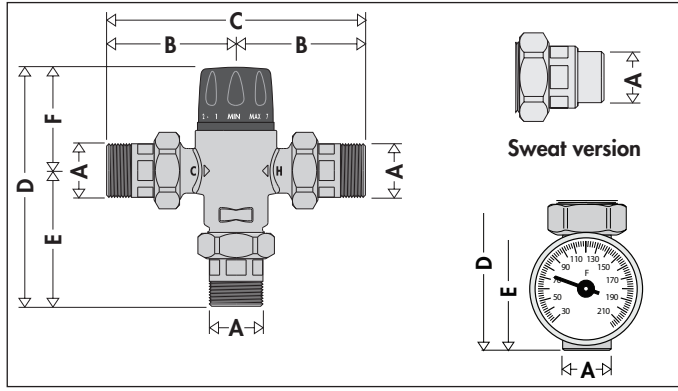

Code	A	B	C	D	E	F	Wt (lb)
523160A	1" NPT	4"	8"	7 5/8"	4 3/16"	3 3/8"	7.0
523168A	1" SWT	3 5/16"	6 5/8"	7"	3 1/2"	3 3/8"	7.0
523170A	1 1/4" NPT	4 1/8"	8 1/4"	7 3/4"	4 5/16"	3 3/8"	7.1
523177A	1 1/4" SWT	3 3/8"	6 3/4"	7 5/8"	4 1/8"	3 3/8"	8.5
523178A	1 1/4" SWT	3 3/8"	6 3/4"	7"	3 1/2"	3 3/8"	7.1
523180A	1 1/2" NPT	5 1/8"	10 1/4"	9 3/16"	5 7/16"	3 3/4"	17
523188A	1 1/2" SWT	4 1/16"	8 1/8"	8 1/8"	4 3/8"	3 3/4"	17
523190A	2" NPT	5 1/8"	10 1/4"	9 1/2"	5 3/4"	3 3/4"	18
523198A	2" SWT	4 5/16"	8 5/8"	8 5/8"	4 7/8"	3 3/4"	18

## “Legionella” - Scalding risk

In systems producing domestic hot water with storage, in order to avoid the dangerous bacteria known as "Legionella", the hot water must be stored at a temperature of at least 140°F. At this temperature it is certain that the growth of the bacteria causing this infection will be totally eliminated. However, at this temperature the water cannot be used directly, as it may cause scalding. For example, at 130°F, partial burning takes place in 30 seconds and at 140°F total burning takes place in 5 seconds. In view of the above, it is necessary to install a thermostatic mixing valve which can:

- reduce the temperature at the point of use to a value lower than that of storage;
- maintain this value when the incoming pressure and temperature conditions vary.

## Thermal disinfection

The diagram below shows the behavior of the bacteria "Legionella Pneumophila" when the temperature conditions of the water in which it is contained vary, in laboratory sample population.

In order to ensure proper thermal "disinfection", the value must not be below 140°F.

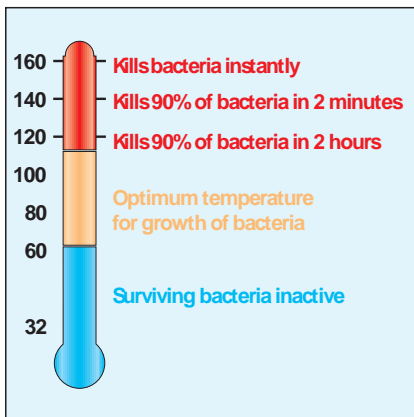

## Reference documents

For the prevention and control of Legionella, see the National Regulations and applicable Code of Practice.

## Principle of Operation

A thermostatic mixing valve mixes hot and cold water in such a way as to maintain a constant set temperature of the mixed water at the outlet.

A thermostatic element is fully immersed into the mixed water. It then contracts or expands causing movement of the piston, closing either the hot or cold inlets, regulating the flow rates entering the valve. If there are variations of temperature or pressure at the inlets, the internal element automatically reacts attempting to restore the original temperature setting.

## Thermal shutoff

In the event of a failure of either the hot or cold supply, the piston will shut off, stopping water discharging from the mixed water outlet.

The Caleffi valve requires a minimum temperature differential from hot inlet to mixed water outlet of 20°F (11°C) to ensure the correct operation of the thermal shutoff feature.

## Construction details

### Double seat

The mixing valve has a special actuator which acts on a double water passage seat. This produces a high flow rate with a reduced resistance, at the same time maintaining accurate temperature control.

### Anti-wear surfaces

The materials of construction in the 5231 series thermostatic mixing valve eliminates the problem of jamming caused by mineral deposits. All the working parts, such as the PPSG40 shutter and EPDM seals, are made of a special anti-scale material, with a low friction coefficient, providing long term high performance.

### Low inertia thermostat

The temperature-sensitive element, the "motor" of the thermostatic mixing valve, is characterized by a low heat inertia; this means that it reacts rapidly to variations in the incoming temperature and pressure conditions, reducing the valve response times.

### Temperature setting and locking

The control knob permits temperature setting, between min. and max., in one turn (360°). It also has a tamper-proof system to lock the temperature at the set value.

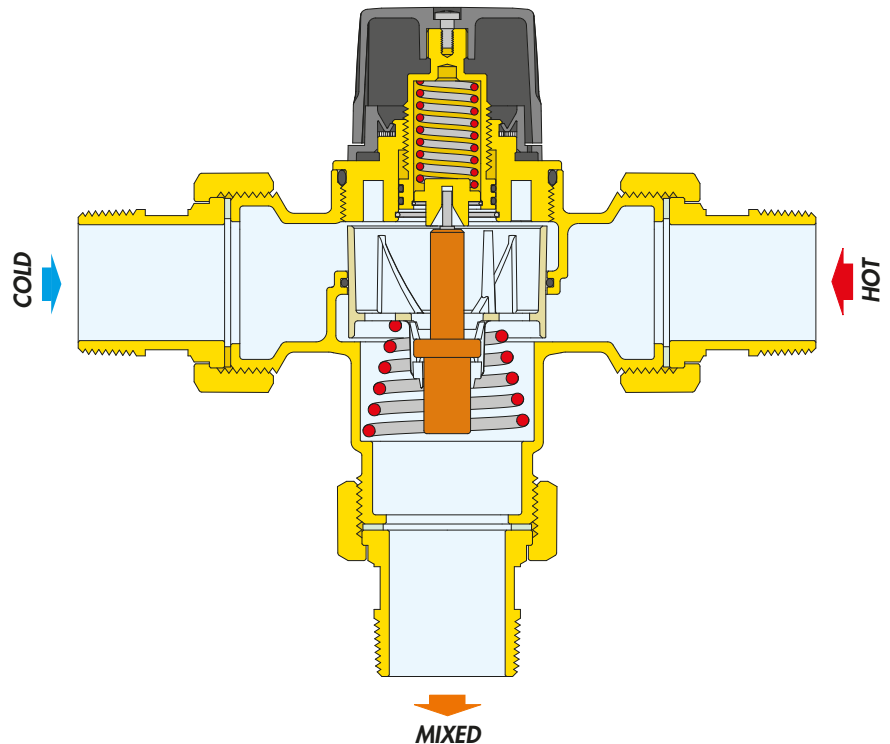

## Use

Caleffi 5231 series thermostatic mixing valves are designed to be installed at the hot water heater (ASSE 1017 models).

ASSE 1017 models are designed to be installed at the hot water heater and cannot be used for tempering water temperature at fixtures as a point-of-use valve. They are not designed to provide scald protection or anti-chill service and should not be used where ASSE 1070 devices are required. Wherever a scald protection feature is required, ASSE 1070 model mixing valves need to be installed. For safety reasons, it is advisable to limit the maximum mixed water temperature to 120°F.

## Instantaneous production of hot water

Caleffi 5231 series thermostatic mixing valves should not be used in conjunction with boilers giving instantaneous production of domestic hot water. This would compromise the correct operation of the boiler.

## Radiant heating systems

Caleffi Series 5231 thermostatic mixing valves can also be used for controlling the flow temperature in radiant heating systems, for constant and accurate control with ease of installation.

## Installation

Before installing a Caleffi 5231 series thermostatic mixing valve, the system must be inspected to ensure that operating conditions are within the range of the mixing valve, checking, for example, the supply temperature, supply pressure, etc.

Systems where the Caleffi 5231 series thermostatic mixing valve will be installed must be drained and cleaned out to remove any dirt or debris which may have accumulated during installation. Failure to remove dirt or debris may affect performance and the manufacturer's product guarantee. Demineralized water use is highly recommended as the warranty is voided if used on water with hardness greater than 10 grains.

The installation of filters of appropriate capacity at the inlet of the water from the supply line is always advisable.

The water must be sufficiently treated before it enters the valve in areas with highly aggressive water. Caleffi 5231 series thermostatic mixing valves must be installed in accordance with the diagrams in this manual, taking into account all current applicable standards.

Caleffi 5231 series thermostatic mixing valves can be installed in any position, either vertical or horizontal.

The following are shown on the thermostatic mixing valves body:

- Hot water inlet, color red.
- Cold water inlet, color blue.
- Mixed water outlet, marked "MIX".

In systems with thermostatic mixing valves, check valves must be installed to prevent undesirable fluid backflow. The 5231 is approved to ASSE 1017, and as such does not contain integral check valves, so those must be sourced separately. It is essential that access to the valve is totally unobstructed for any maintenance which may be required to the valve or connections. The piping from/to the valve must not be used to support the weight of the valve itself.

## Commissioning

After installation, the valve must be tested and commissioned in accordance with the instructions given below, taking into account current applicable standards.

- 1) The system must be clean and free from any dirt or debris before commissioning the thermostatic mixing valves. Be sure water hardness is less than 10 grains.
- 2) It is recommended that the temperature is set using a suitable calibrated digital thermometer. The valve must be commissioned by measuring the temperature of the mixed water at the outlet.
- 3) The maximum outlet temperature from the valve must be set taking account of the fluctuations due to simultaneous use.
- 4) Adjust the temperature using the adjusting knob on the valve. For safety reasons, it is advisable to limit the maximum mixed water temperature to 120°F in domestic hot water systems.

## Temperature setting

The temperature is set to the required value by means of the knob with the graduated scale, located on the top of the valve.

## Locking the setting

Position the knob at the required value, unscrew the top screw, slide off the knob and put it back in such a way that the handle fits into the internal slot of the knob. Tighten the head screw.

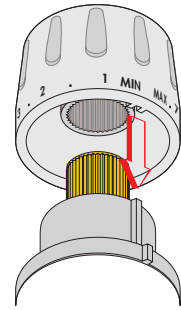

## Point of Distribution ASSE 1017 Approved

Size	Connection	Model	Min. Flow* (GPM)	Max. Flow* (GPM)	CV
1"	NPT	523160A	4.4	40	7
1"	Sweat	523168A	4.4	40	7
1 ¼"	NPT	523170A	4.4	40	7.6
1 ¼"	Sweat w/ temp	523177A	4.4	40	7.6
1 ¼"	Sweat	523178A	4.4	40	7.6
1 ½"	NPT	523180A	8.8	70	13
1 ½"	Sweat	523188A	8.8	70	13
2"	NPT	523190A	8.8	70	14.2
2"	Sweat	523198A	8.8	70	14.2

\*Recommended flow rates for temperature stability: ± 3°F (± 2°C).

## Setting the temperature

The temperature is set to the required value by means of the adjusting knob with the graduated scale on the top of the valve.

Pos.	Min	1	2	3	4	5	6	7	Max
T (°F)	95	104	109	117	122	129	136	142	150
T (°C)	35	40	43	47	50	54	58	61	66

with:  $T_{HOT} = 155^{\circ}F (68^{\circ}C)$  ·  $T_{COLD} = 55^{\circ}F (13^{\circ}C)$  ·  $P_{INLET} = 43 \text{ psi (3 bar)}$

## Flow curve

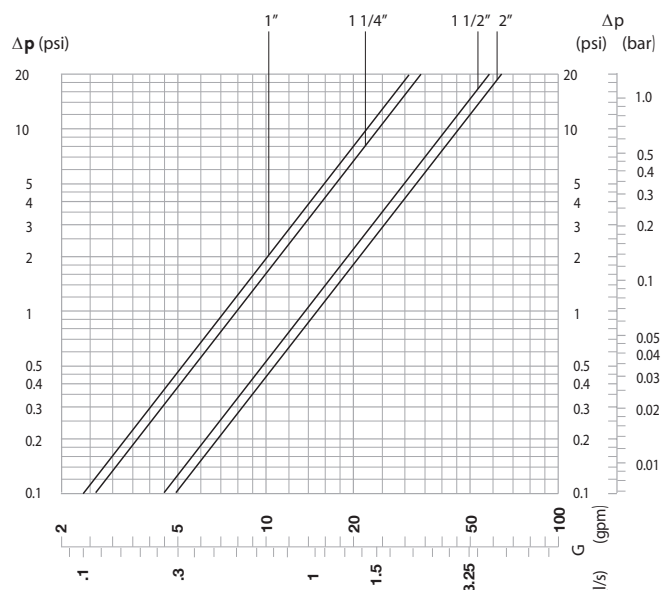



**Caution:** In systems with thermostatic mixing valves, check valves must be installed to prevent undesirable fluid backflow. The 5231 models do not contain integral check valves, and must be sourced separately.

## Applications diagrams

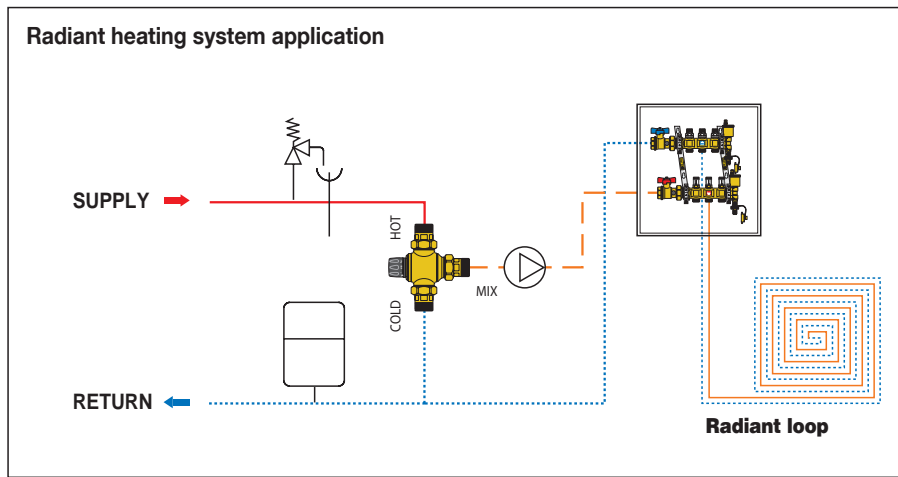
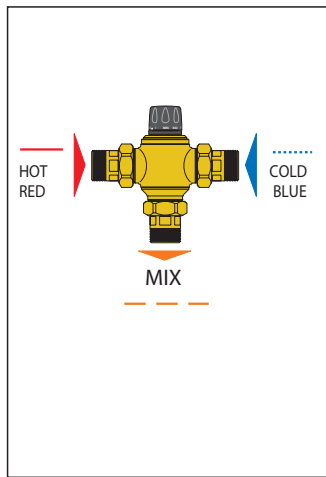

### Recirculation with point-of-distribution thermostatic mixing valves

For domestic recirculating systems that include a single ASSE 1017 point-of-distribution thermostatic mixing valve, such as the Caleffi 5231 series thermostatic mixing valves, the piping installation below is recommended.

In any recirculating hot water distribution system there will be times when the circulator is operating, but no hot water is being drawn at the fixtures. Under this condition, heat continually dissipates from the piping forming the recirculation loop. If the loop is relatively short, and well insulated, the rate of heat loss should be very small. If the loop is long, and uninsulated, the rate of heat loss could be substantially greater.

To maintain the recirculating water at the desired delivery temperature the heat lost from the loop must be replaced. This requires some water flow between the loop and the hot water source. Ideally, this flow is adjusted so that the rate of heat transfer from the hot water source to the loop exactly balances the rate of heat loss from the loop's piping.

The figure (below right) shows a "bypass valve" (1), and "return valve" (2), which regulates how much warm water from the return side of the recirculating loop flows back to the storage tank. When there is no demand for hot water at the fixtures, the flow of return water to the tank will equal the rate of hot water flow from the tank to the inlet port of the mixing valve. Ideally, this flow should be adjusted so that the rate of heat transfer from the tank to the recirculating

loop exactly balances the rate of heat loss from the recirculating loop. This allows the water temperature leaving the mixing valve to remain stable.

The bypass valve (1) and possibly the return valve (2) must be adjusted when there is no domestic water draw on the recirculating loop (when all the fixtures are off). Begin with the bypass valve (1) fully closed, and the return valve (2) fully open. Turn on the recirculating circulator and let it run for several minutes. The supply water temperature leaving the mixing valve will likely be lower than the setting of the valve, since there is no return flow to the tank.

Slowly open the bypass valve (1) and monitor the temperature leaving the mixing valve. It will likely begin rising as some water returns to the tank, and an equal flow of hot water moves from the tank to the hot port of the mixing valve. When the temperature leaving the mixing valve remains stable, and is at or very close to the temperature set on the mixing valve, the bypass valve is correctly set.

The return valve (2) can remain fully open unless a situation occurs where the bypass valve (1) is fully open, but the temperature leaving the mixing valve is still too low. If this occurs, partially close the return valve (2) to add flow resistance. This forces more flow through the bypass valve (1). Repeat the previously described procedure of slowly opening the bypass valve (1) until the water temperature leaving the mixing valve is stable.

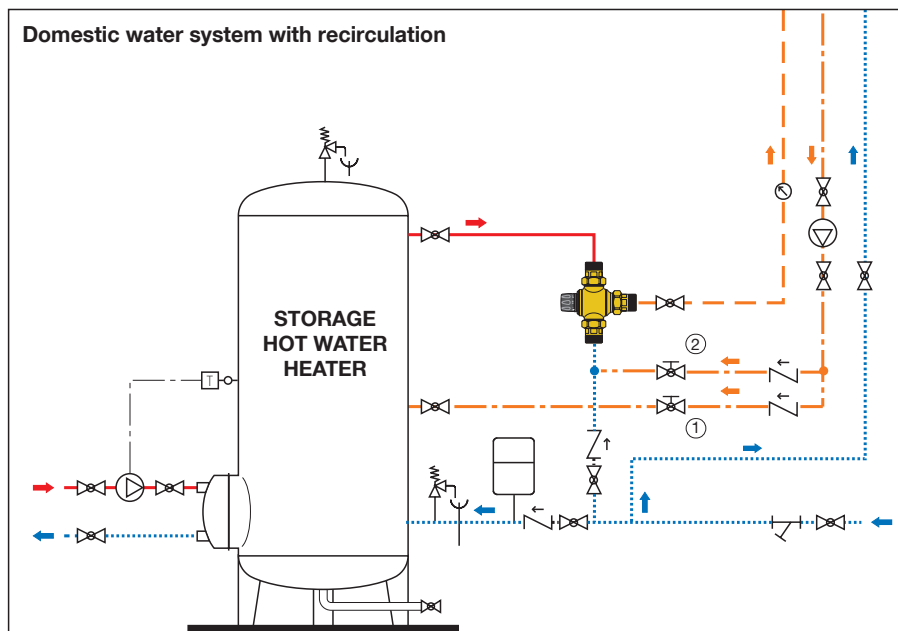
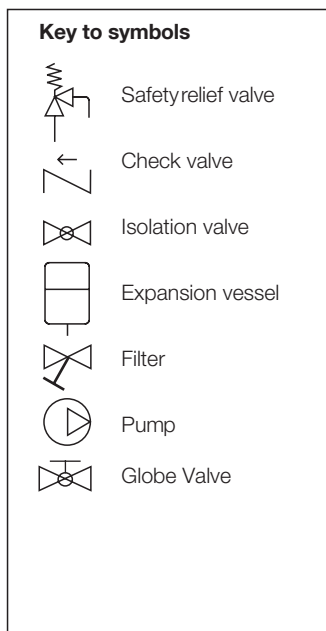

---

## SPECIFICATION SUMMARIES

---

### **5231 series**

Adjustable thermostatic mixing valve. cUPC Listed to ASSE 1017/CSA B125.3. Threaded NPT or sweat connections from 1" to 2" with unions and tailpieces. Low-lead brass body (<0.25% lead content) certified by IAPMO R&T. Meets requirements of ANSI/NSF 372-2011. PPSG40 shutter, stainless steel springs, and EPDM seals. Maximum working pressure 200 psi (14 bar). Maximum operating differential pressure 70 psi (5 bar). Mixed temperature setting range 95 to 150°F (35 to 66°C), Temperature stability  $\pm 3^{\circ}\text{F}$  ( $\pm 2^{\circ}\text{C}$ ), Maximum water hardness: 10 grains. Provided with tamper-proof temperature locking. Provide with optional mixed outlet temperature gauge for 1 1/4" union sweat model, 30 to 210°F scale, 2 inch diameter.

---

*We reserve the right to change our products and their relevant technical data, contained in this publication, at any time and without prior notice.*

---



Caleffi North America, Inc.  
3883 W. Milwaukee Road  
Milwaukee, WI 53208  
Tel: 414-238-2360 · Fax: 414-238-2366  
sales@caleffi.com · www.caleffi.com/usa/en-us  
© Copyright 2014 Caleffi North America, Inc.