



INSTALLATION AND MAINTENANCE INSTRUCTIONS

IM-2-300-US

APRIL 2013

Float & Thermostatic Steam Traps FT, FTB, FTI, OK, FTS-150, FTS-300

Description and Operation

Spirax Sarco Float & Thermostatic Steam Traps are ideally suited for most HVAC and process applications. The spherical stainless steel float automatically adjusts the position of the main valve so that condensate is discharged continuously at the same rate as it enters the trap. Air and other non-condensable gases which are present at start up or which enter the trap during operation are discharged through the integral balanced pressure thermostatic air vent (some high pressure F & T traps have a bimetal air vent). The traps will operate against any back-pressure lower than the inlet pressure. (The differential pressure—inlet pressure minus outlet pressure—determines the trap's capacity).

All Spirax Sarco F & T traps will tolerate at least 450°F of temperature. The superheat tolerance of some models is higher; refer to the appropriate Technical Information Sheet or call Spirax Sarco for further information.

Limiting Operating Conditions

The maximum operating pressure (PMO) is shown on the nameplate. The PMO depends on the valve mechanism; if the pressure at the trap inlet is higher than the PMO, the excess pressure may lock the valve closed. In some cases (for example, if there is a permanent back-pressure in the return line) it may be permissible to exceed the PMO. Please consult Spirax Sarco for details.

The maximum operating temperature depends on the superheat tolerance of the air vent. This is always at least 450°F as the TMA (see below) is not exceeded.

The maximum allowable pressure and temperature (PMA and TMA) are determined by the pressure shell design conditions, and must not be permanently exceeded. The trap may be subjected to a temporary cold hydraulic test pressure of 1-1/2 times the cold PMA, provided that the air vent is first removed. If the test pressure will exceed 600 psi, the float must also be removed.

Installation

1. Before installation, inspection or maintenance, the trap must be isolated from both supply and return line pressure.
2. The trap should be installed below the drainage point of the equipment or steam main so that condensate can flow by gravity into the trap. A vertical drop to the trap is advantageous, but long horizontal runs should be avoided because of the possibility of steam locking. If a long horizontal run to the trap is unavoidable, a trap with a steam lock release should be used.
3. If possible, a drop leg and dirt pocket should be installed ahead of the trap. The trap should be protected by a Spirax Sarco y-pattern stainer, preferably fitted with a blow down valve. Full-port isolating valves should be installed to permit servicing.
4. The trap must be installed in an upright position with the orientation arrow on the body or on the nameplate pointing straight down. The flow direction markings on the body or cover must be observed.
5. Before installing the trap, the inlet piping should be carefully blown down to remove any existing debris.
6. A Spira-tec® sensor chamber facilitates checking the trap's operation. A check valve downstream of the trap will prevent backflow from the return line.
7. If the condensate must be lifted to the return main, the trap, followed by a check valve, should be installed at the bottom of the lift. Sufficient pressure to lift the condensate (approximately 1 psi for each 2 ft. of lift) must be present at the trap inlet at all times.
Note that a temperature control valve on the inlet steam may at times reduce the pressure below the amount required to lift the condensate. When the inlet steam is controlled and condensate must be lifted after the trap, a Spirax Sarco Pressure Powered Pump™ should be considered.
8. Bypass piping is not recommended because of the possibility of misuse. If continuous service is required, a second trap could be piped in parallel with suitable valving to allow one trap to be serviced while the other remains in operation. If a bypass line must be used, it should be at least one pipe size smaller than the trap.
9. Because condensate cannot drain completely from the body, an F & T trap installed outdoors can freeze up if it is not in continuous operation. If there is a possibility of an interruption in the steam supply, provisions should be made for draining or tracing the trap body.
10. The trap can be put into service by slowly opening the isolating valves. No priming is necessary.

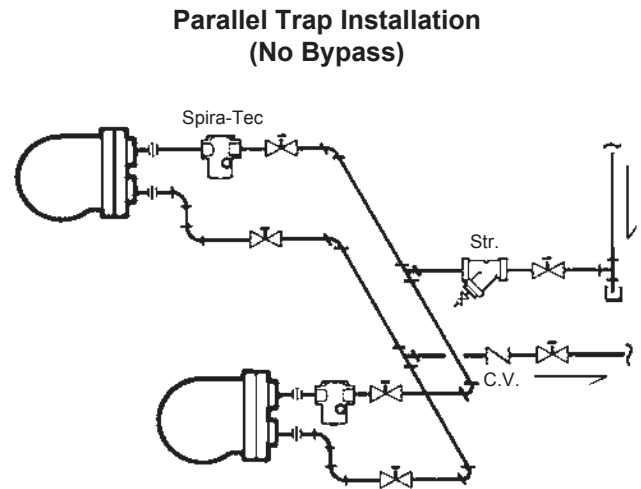
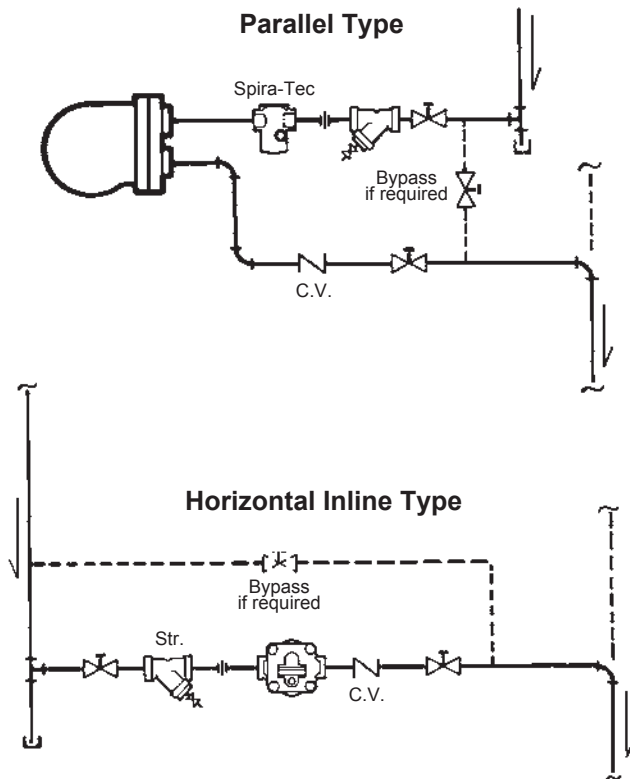

Maintenance

1. After isolation from supply and return line pressure, all Spirax Sarco F & T traps can be serviced without disturbing the piping connections. On some models the cover with mechanism attached can be removed for servicing while the body remains in the pipeline.
2. On most models, dirt and sludge which may accumulate in the trap can be removed by "blowing down" through the drain plug in the bottom of the body.
3. The trap should be disassembled periodically for inspection and replacement if necessary of the valve mechanism and air vent.
4. Ensure that the trap is properly isolated, and that any pressure which may remain in the trap is relieved before the trap is opened. This can be accomplished by opening the blowdown valve on the upstream strainer and waiting until the trap has cooled. Some condensate will remain in the trap body. This can be drained by removing the drain plug or by cracking the body-cover joint.
5. Remove and save the cover bolts, and remove the body or cover. Using a suitable solvent, clean all dirt and incrustation from the body, cover and mechanism. Inspect the body and cover for condensate corrosion.
6. Inspect the valve head and seat for damage, wear

or wiredrawing. Replace the mechanism if necessary, using a complete valve mechanism kit and following the instructions included with the kit.

7. Inspect the float for leakage or damage, and replace if necessary. A distorted or collapsed float is evidence of a severe and dangerous overpressure or waterhammer condition which must be corrected before the trap is returned to service.
8. The air vent should be removed, tested for proper operation, and replaced if necessary. Instructions are included with the air vent kit.
9. Remove all traces of the old gasket from the body and cover, and ensure that the gasket surfaces are clean and undamaged. Using a new cover gasket, reassemble the trap. Tighten the cover bolts to the torque shown on page 3.
10. The trap can be returned to service by slowly opening the isolating valves. Priming is not required.

Note: Flash steam is formed when a portion of the hot condensate re-evaporates as it passes from a higher to a lower pressure (for example, as it flows through a steam trap). This flash steam is normal, and it should not be mistaken for live steam leakage when the operation of the trap is being observed.

Spare Parts

The following spare parts are available for Spirax Sarco Float & Thermostatic Steam traps:

Valve Mechanism Kit - Complete valve mechanism with mechanism gasket and mounting screws as required. A separate cover gasket kit should be ordered when replacing mechanism parts.

Gasket Kit - Three each of cover and mechanism gaskets.

Air Vent Kit - Air vent assembly.

Replacement Kit - Valve mechanism with gasket, float with screw and washer, air vent assembly, cover gasket.

Float Kit - Float with screw and lockwasher as required.

Note: In some models, the float is welded to the mechanism arm, and is included in the valve mechanism kit. A separate float kit is not available.

Model	Size(s)	Spare Parts Kits*			Torque Values ft-lb		TIS Number
		Valve Mechanism Kit	Gasket Kit	Float Kit	Cover Bolts	Valve Seat or mounting screws	
FT-15	3/4", 1"	54749	55475	55448	11-14	27-31	2.313
	Replacement Module: 67908						
	1-1/4"	54752	55475	55447	11-14	34-37	
		Replacement Module: 67909					
FT-30	3/4", 1"	58131	58127	58129	11-14	27-31	
		58135	58128	58130			
	Replacement Module: 68592						
	1-1/4"	58139	55475	55447	11-14	34-37	
Replacement Module: 68595							
FT-75	3/4", 1"	58132	58127	58129	11-14	27-31	
		58136	58128	58130			
	Replacement Module: 68593						
	1-1/4", 1-1/2" 2"	58133	58127	58129	17-21	90-95	
58137		58128	58130	17-21	90-95		
FT-125	3/4", 1"	54750	55475	55447	11-14	27-31	
		Replacement Module: 68594					
	1-1/4", 1-1/2" 2	58134	58127	58129	17-21	90-95	
		58138	58128	58130			
FTI	15 30 75 125 200	54749	67049	55448	17-21	27-31	
		54749		55447			
		54750		55447			
		54751		55447			
		67048		55447			
		67048		55447			
FTI	15 30 75 125 200	74323	74327	74328	80-85	90-95	
		74324					
		74325					
		74326					
		74326					
		74326					
FT-150	3/4", 1"	80087	55481	55447	17-21	8-11	
	1-1/4", 1-1/2"	80090	55482	58130	27-31		
FT-200	3/4", 1"	81850	55481	55447	17-21	8-11	
	1-1/4", 1-1/2"	80091	55482	58130	27-31		
FTB-20	2"	58152	55479	58159	17-21	150-155	
FTB-30	2"	58177	58173	58160	85-90	53-55	
FTB-125	2-1/2"	58177	CI 58173/CS 68806	58160	85-90	53-55	
FTB-200	2-1/2"	58158	68806	58160	85-90	16-19	
FTB-50	1-1/2"	58179	58180	58129	23-27	8-11	
FTB-175	2"	61044	55479	58159	23-27	8-11	
	2-1/2"	58158	58173	58160	85-90	16-19	
FTB-200	1-1/2"	58179	74122	74123	27-31	8-11	
OK 150, FTS150 OK 300, FTS300	1/2"	63353	66576	55447	15-17	17-19	
		63354					
FT450-	4.5 10 14 21 32	66379	66392	N/A	27-31	27-31	
		66380					
		66381					
		66382					
		66383					
		66383					
FT450-	4.5 10 14 21 32	66384	66392	N/A	27-31	27-31	
		66385					
		66386					
		66387					
		66388					
		66388					
FT450-	4.5 10 32	66395	66393	62541	80-85	7-9	
		66396					
		66397					
FT450-	4.5 10 32	66389	66394	62541	93-97	15-18	
		66390					
		66391					

* Air Vent Kits - see next page

Air Vent Kits

Model	Air Vent Kit No.	Air Vent Seat Torque ft•lb
FT-450 4.5 to 32	71512	26-30
FT-450 with bimetal option	66642	37-40
All Others	62652	26-30

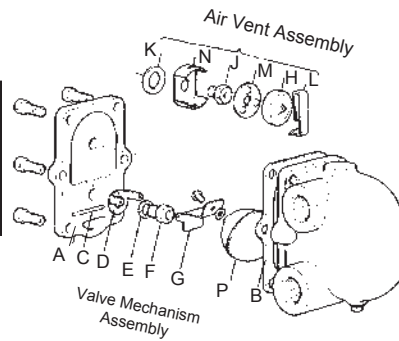

3/4", 1" FT-15/30/75/125
1-1/4" FT-15/30

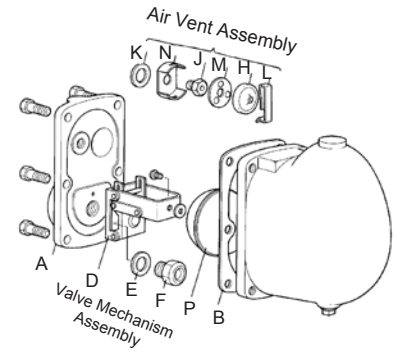

1-1/4" FT-75/125
1-1/2" FT-15/30/75/125
2" FTB-20

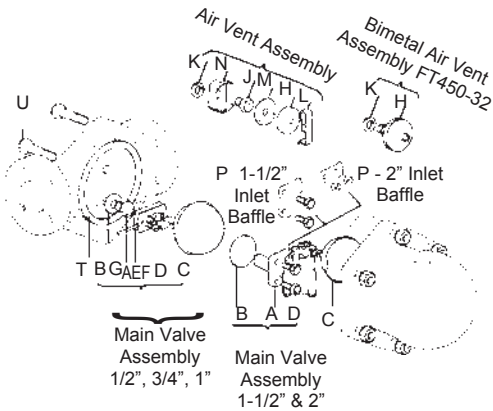

3/4", 1", 1-1/2" FT450

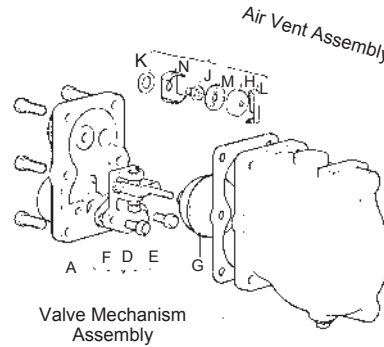

3/4", 1", 1-1/4", 1-1/2" FT-150/200

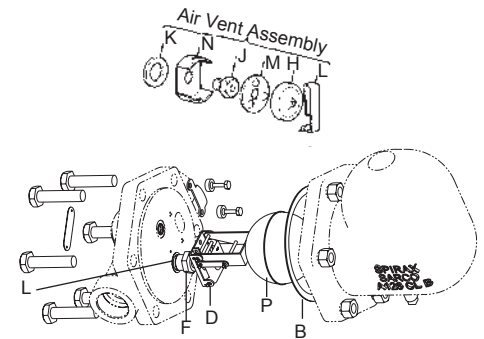

1-1/2" FTI 15 to 200

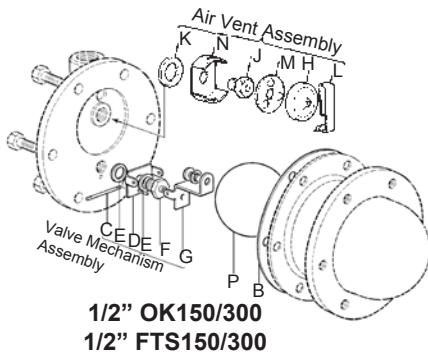

1/2" OK150/300
1/2" FTS150/300

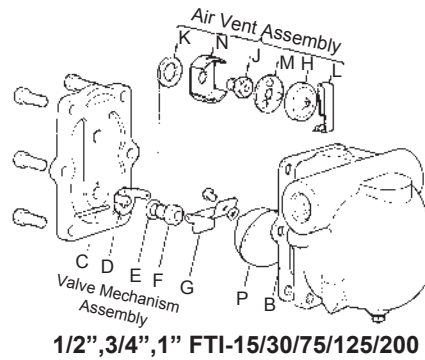

1/2", 3/4", 1" FTI-15/30/75/125/200

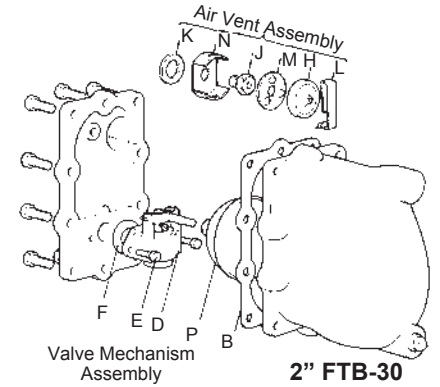

2" FTB-30
2-1/2" FTB-125
2-1/2" FTB-175
2" FTB-175

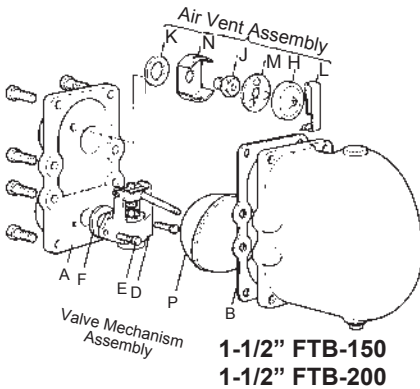

1-1/2" FTB-150
1-1/2" FTB-200

For any additional information you may require, contact: Spirax Sarco Applications Engineering Department
Toll Free 1-800-833-3246

spirax sarco

SPIRAX SARCO, INC. • 1150 NORTHPOINT BLVD. • BLYTHEWOOD, SC 29016
PHONE 803-714-2000 • FAX 803-714-2222
WWW.SPIRAXSARCO.COM/US