

**For Residential and Commercial Applications**

Job Name		Engineer / Architect	
Job Location		Wholesaler	
Submittal Date		Contractor	

## BRPX1B/ BRPX09/ BRPX19 Multi-Turn Angle Stop – Barbed PEX x Compression

**Use:** For use with water in accessible locations only. Not intended for recirculating systems that produce continuous use temperatures above 115° F. For those applications, use our KT™ series ball stop.

**Design Features:**

- **Machined one-piece brass body** provides strength, durability, and long-lasting performance
- **Knurled oval handle** provides a secure grip and smooth on/off operation
- **Easy-to-remove handle** with screw attachment helps protect against accidental stop operation during rough-ins
- **No Lead**
- **PEX end** designed to ASTM F1807
- **For use with** ASTM F876 PEX tubing, in ASTM F877 water distribution systems using ASTM F1807, and/or F2098 connection methods

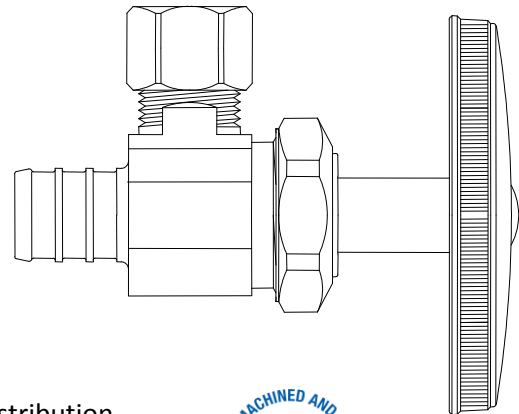

**Operating Specifications:**

**Temperature:** 40°- 140° F  
**Pressure:** 125 PSI maximum

**Standard**

STOP MATERIAL SPECIFICATIONS	
<b>Body</b>	<i>Brass, chrome plated</i>
<b>Stem</b>	<i>POM</i>
<b>Bib &amp; Packing Washer</b>	<i>Rubber</i>
<b>Packing Nut</b>	<i>Brass or brass, chrome plated</i>
<b>Handle</b>	<i>Polycarbonate</i>
<b>Handle Screw</b>	<i>Steel, plated</i>
<b>Plastic Sleeve</b>	<i>Plastic</i>
<b>Compression Nut</b>	<i>Brass, chrome plated</i>
<b>Compression Sleeve</b>	<i>Brass</i>
<b>Loose Key</b>	<i>Zinc die cast</i>
<b>Lock Shield</b>	<i>Brass, chrome plated</i>
<b>Loose Key Stem</b>	<i>Brass, plated</i>

**No Lead**

STOP MATERIAL SPECIFICATIONS	
<b>Body</b>	<i>No-Lead brass, chrome plated</i>
<b>Stem</b>	<i>POM</i>
<b>Bib &amp; Packing Washer</b>	<i>Rubber</i>
<b>Packing Nut</b>	<i>Brass or brass, chrome plated</i>
<b>Handle</b>	<i>Polycarbonate</i>
<b>Handle Screw</b>	<i>Steel, plated</i>
<b>Plastic Sleeve</b>	<i>Plastic</i>
<b>Compression Nut</b>	<i>Brass, chrome plated</i>
<b>Compression Sleeve</b>	<i>Brass</i>
<b>Loose Key</b>	<i>Zinc die cast</i>
<b>Lock Shield</b>	<i>Brass, chrome plated</i>
<b>Loose Key Stem</b>	<i>No Lead brass, plated</i>

*This specification and all information contained herein is the confidential and exclusive property of BrassCraft Manufacturing, and shall not be disclosed to others without the written consent of BrassCraft Mfg. This specification must be returned to BrassCraft Mfg. if requested.*



# BRPX1B/ BRPX09/ BRPX19 Multi-Turn Angle Stop – Barbed PEX x Compression

## Standard Part Listing:

- BRPX1B C      3/8" nom crimp barb (for PEX) x 3/8" OD compression, chrome plated
- BRPX09 C      1/2" nom crimp barb (for PEX) x 1/4" OD compression, chrome plated
- BRPX09 CBT    1/2" nom crimp barb (for PEX) x 1/4" OD compression, chrome plated, plain tray, bulk
- BRPX09 R      1/2" nom crimp barb (for PEX) x 1/4" OD compression, rough brass
- BRPX19 C      1/2" nom crimp barb (for PEX) x 3/8" OD compression, chrome plated
- BRPX19 C1     1/2" nom crimp barb (for PEX) x 3/8" OD compression, chrome plated, window tray
- BRPX19 R      1/2" nom crimp barb (for PEX) x 3/8" OD compression, rough brass
- SBRPX19 C     1/2" nom crimp barb (for PEX) x 3/8" OD compression, loose key, chrome plated

## No-Lead Part Listing:

- BRPX19X C     1/2" nom crimp barb (for PEX) x 3/8" OD compression, chrome plated
- BRPX19X R     1/2" nom crimp barb (for PEX) x 3/8" OD compression, rough brass
- SBRPX19X C    1/2" nom crimp barb (for PEX) x 3/8" OD compression, loose key, chrome plated

PART DIMENSIONS (Inches)		
Model	DIM A	DIM B
BRPX1B	1.06	2.72
BRPX09	1.06	2.79
BRPX19 / 19X	1.06	2.79
SBRPX19 / 19X	1.06	2.32

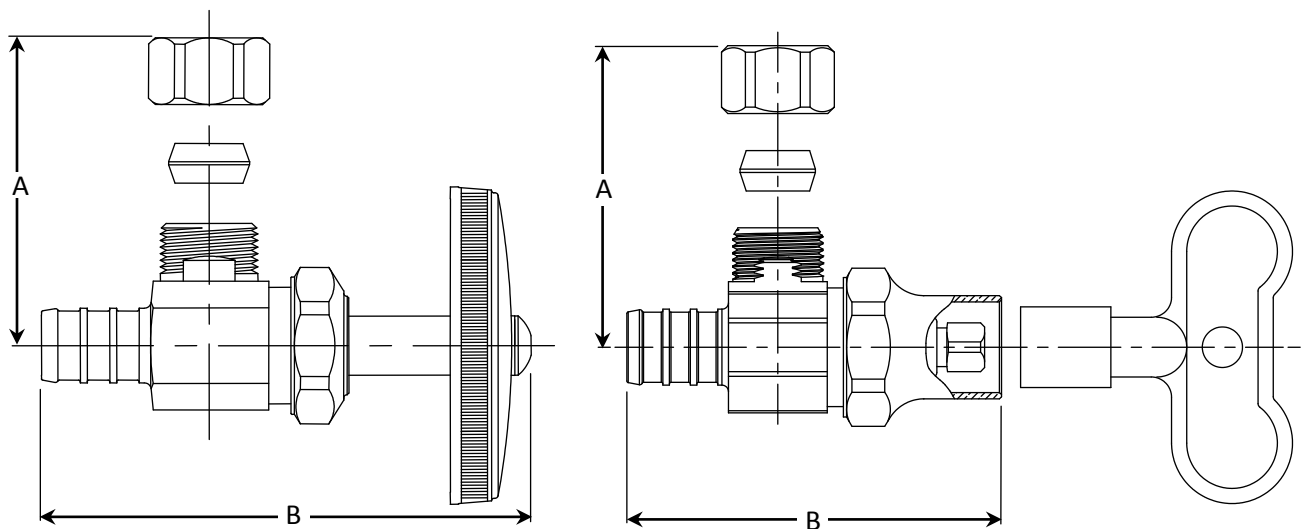

## Listings & Certifications:

- IAPMO listed to ASME A112.18.1 / CSA B125.1 (File # 0645)
- CSA listed to ASME A112.18.1 / CSA B125.1 (File # 204593)
- No-Lead product CSA listed to Low Lead Content Certification Program – Plumbing Products Class 6853-01



*This specification and all information contained herein is the confidential and exclusive property of BrassCraft Manufacturing, and shall not be disclosed to others without the written consent of BrassCraft Mfg. This specification must be returned to BrassCraft Mfg. if requested.*

**BrassCraft®**