

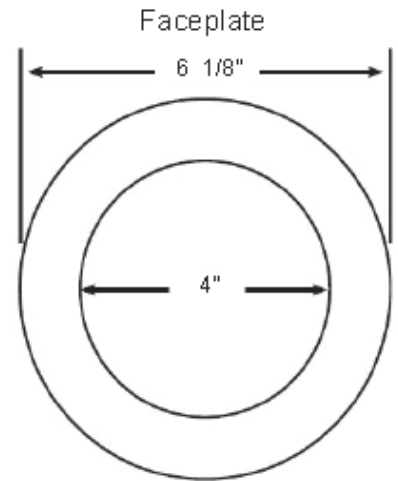

ROUND MINI ICE MAKER OUTLET BOXES with Hammer Arrester Lead Free Valve and Preloaded Mounting Nails

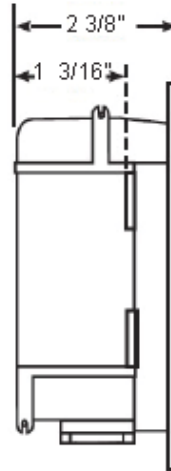
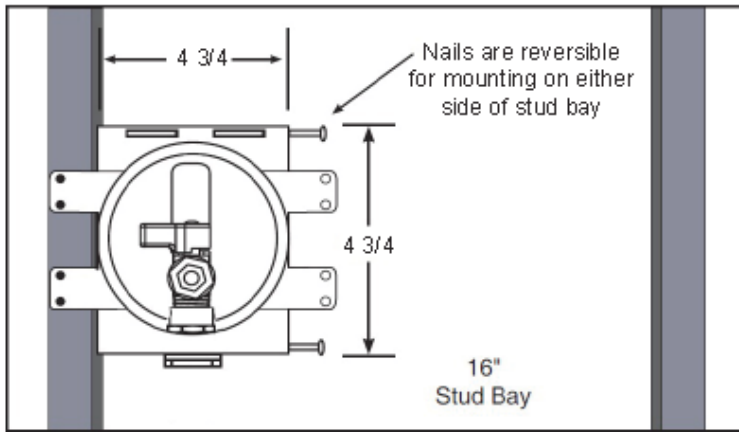

Specification:

Furnish and install miniature round ice maker outlet box with preloaded mounting nails and lead free valve with integral hammer arrester. Unit shall be Water-Tite product code checked below as manufactured by IPS Corporation. Valves comply with ASME A112.18.1. Hammer arresters comply with ASSE 1010.

Note: Valve is for illustration purposes only. See description below for valve options.

Product Code #	Product Description	Model Number	Units/Case
88372	Mini Round 1/4 Turn Lead Free Valve, 1/2" Sweat Conx.	AB9200HA	10
88377	Mini Round 1/4 Turn Lead Free Valve, 1/2" PEX Conx.	AB9202HA	10
88376	Mini Round 1/4 Turn Lead Free Valve, 1/2" CPVC Conx.	AB9201HA	10
88379	Mini Round 1/4 Turn Lead Free Valve, 1/2" Wirsbo® Conx.	AB9211HA	10
88373	Mini Round 1/4 Turn Lead Free Valve, 1/2" Sweat Conx., Contractor Pack	AB9200HACP	20
88378	Mini Round 1/4 Turn Lead Free Valve, 1/2" PEX Conx., Contractor Pack	AB9202HACP	20
88376	Mini Round 1/4 Turn Lead Free Valve, 1/2" CPVC Conx., Contractor Pack	AB9201HACP	20
88380	Mini Round 1/4 Turn Lead Free valve, 1/2" Wirsbo® Conx., Contractor Pack	AB9211HACP	20



www.ipscorp.com watertite@ipscorp.com

500 Distribution Parkway, Collierville, TN 38017, USA ■ TEL: 901-853-5001 ■ WATS: 800-888-8312 ■ FAX: 901-853-5008